

UPS **MILITARY** **FIELD-GRADE**

Uninterruptible Power Supply



Shallow Rack



Smaller

Lighter

More Powerful



Sealed Weather-Proof Construction

SynQor[®]

UPS **MILITARY** **FIELD-GRADE** Uninterruptible Power Supply

SynQor's Military Field-Grade Uninterruptible Power Supply units are designed for the extreme environmental and demanding electrical conditions of Military/Aerospace applications. SynQor's UPS incorporates field proven high efficiency designs and rugged packaging technologies. This UPS will accept a wide range of input voltage and frequency values while delivering a well-conditioned AC output to the load. The use of lithium polymer batteries permits the lowest profile and lowest weight solution in its power class. It is designed to comply with a wide range of military standards. Options include two DC outputs, a DC input rated for military 28 VDC sources, and an electronic breaker on the AC output to permit fault-tolerant parallel operation for higher power and/or N+M redundant systems.

UPS PRODUCT FEATURES

- ◆ Sealed, weather-proof, shock-proof construction
- ◆ Military Tough, Die-Cast Aluminum Chassis
- ◆ 1250W-1500VA output power
- ◆ >10 minute run-time at full power
- ◆ Full power operation -20°C to +50°C (Storage: -40°C to +65°C)
- ◆ True on-line double conversion
- ◆ Hot swappable internal battery pack (lithium polymer)
- ◆ Universal AC input: 80-265VAC; 47-65Hz
- ◆ Dual input: AC and optional DC
- ◆ True on-line double conversion
- ◆ Cold-start with no AC or DC input connections
- ◆ Power factor correction at AC input
- ◆ Pure sinusoidal AC output voltage (115VAC, 60Hz)
- ◆ Handles 0.0—1.0 power factor loads and non-linear loads
- ◆ User I/O and Configuration signal ports
- ◆ Up to 3 units can be combined for higher power, voltage or a 3-Phase AC output
- ◆ Up to 32 units can be combined to form a higher power, fault-tolerant, glitch-free system, perhaps with N+M redundancy, by ordering with the "AC Output Electronic Breaker" option and the appropriate configuration cable
- ◆ Shallow rack mount unit (17.00"W x 13.80"D x 3.40"H)
- ◆ Low weight: 33 lbs. (including battery)

OPTIONS

- ◆ DC input (28Vnom) for dual source
- ◆ Wide-range AC input frequency: 47Hz to 800Hz
- ◆ 115Vrms or 230Vrms AC output
- ◆ 50Hz, 60Hz, or 400Hz output
- ◆ DC1: Auxiliary isolated DC output (up to 500W)
- ◆ DC2: High power DC output parallelable for higher power (UPS-1500 up to 1250W)
- ◆ Shipboard version with floating neutral wire
- ◆ N + 1 Redundancy

IN-LINE MANUFACTURING PROCESS

- ◆ AS9100 and ISO 9001 certified facility
- ◆ Full component traceability

SPECIFICATION COMPLIANCE

- UPS units are designed to meet:**
- ◆ MIL-STD-461F - Electromagnetic Interference
 - ◆ MIL-STD-704F - Aircraft Electrical Power
 - ◆ MIL-STD-810G - Environmental Engineering
 - ◆ MIL-STD-1275D - Vehicle Electrical Power
 - ◆ Mil-STD-1399-300B - Interface Shipboard

AC & DC Output Options

Base Model				
Model Number	Power	Battery Run-Time@Full Power (80% Power)	Height (W x D x H)	Weight
UPS-1500-S-2S (1 Standard Battery Pack)	1250 W 1500 VA	>10 min. (>13 min.)	2U (17" x 13.80" x 3.40")	33 lbs.

Base Models	Options						
	AC Input Freq Type	AC Output Voltage	AC Output Neutral Wire	AC Output Set Point Freq	DC Input / DC2 Output	DC1 Output	Additional Options
UPS-1500-S-2S-	L W	1 2	G F R	5 6 4	S D M P R V W	00 12 15 24 28 40 50	-C 00 -E CE

Not all combinations make valid part numbers, please contact SynQor for availability. See the Product Summary web page for more options.

***Notes:**

Order "F: Floating" option when configuring the AC output for multi-unit combinations of up to 3 units.

Order "R: AC Output Electronic Breaker" option for fault-tolerant, glitch-free parallel systems of up to 32 units with N+M redundancy. The AC output neutral wire will not be connected to the chassis. Requires Ethernet / SNMP Option.

Examples:

UPS-1500-S-2S-L1G6D28-C00, UPS-1500-S-2S-L2G5S00-E00
UPS-1500-S-2S-L2G5S00-ECE (230 V output with CE marking)

Options	
AC Input Freq Type	L 47-65 Hz W 47-800 Hz
AC Output Voltage	1 115 Vrms 2 230 Vrms
AC Output Neutral Wire	G Grounded F Floating* R AC Output Electronic Breaker*
AC Output Set Point Freq	5 50 Hz 6 60 Hz 4 400 Hz
DC Input / DC2 Output	S Not Installed D DC Input M DC2 Out 24 VDC with Droop Share P DC2 Out 24 VDC No Share R DC2 Out 28 VDC with Droop Share V DC2 Out 28 VDC No Share W DC2 Out 50 VDC No Share
DC1 Output	00 None 12 12 V 15 15 V 24 24 V 28 28 V 40 40 V 50 50 V
Additional Options	-E Ethernet/SNMP -C Ethernet/SNMP with Configuration Loading 00 No CE Marking CE CE Marking

DC Only Output Options

Base Model				
Model Number	Power	Battery Run-Time@Full Power (80% Power)	Height (W x D x H)	Weight
UPS-1250-S-2S (1 Standard Battery Pack)	1250 W	>10 min. (>13 min.)	2U (17" x 13.80" x 3.40")	33 lbs.

Base Models	Options				
	AC Input Freq	DC Regulation Type	DC Output Voltage	DC Input	Additional Options
UPS-1250-S-2S-	L W	R	24 28	D00	-E 00 -C CE

Not all combinations make valid part numbers, contact SynQor for availability. See the Product Summary web page for more options.

Examples: UPS-1250-S-2S-LR28D00-E00, UPS-1250-S-2S-WR28D00-E00,
UPS-1250-S-2S-LR28D00-CCE (with CE mark)

Options	
AC Input Freq	L 47-65 Hz W 47-800 Hz
DC Regulation	R Fully Regulated
DC Output	24 24 V Output 28 28 V Output
DC Input	D00 DC Input
Additional Options	-E Ethernet/SNMP -C Ethernet/SNMP with Configuration Loading 00 No CE Marking CE CE Marking

MECHANICAL DIAGRAM

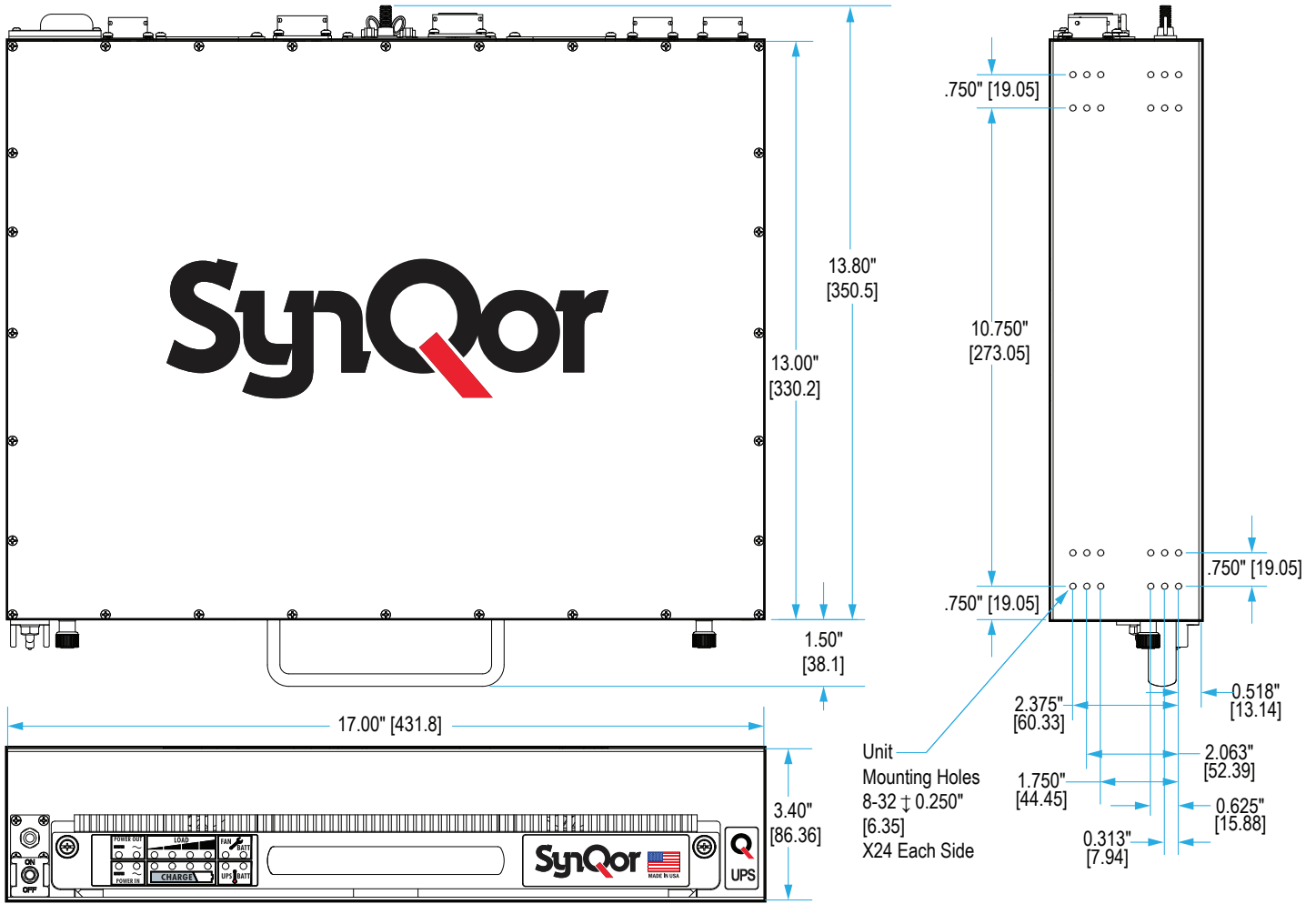

BLOCK DIAGRAM

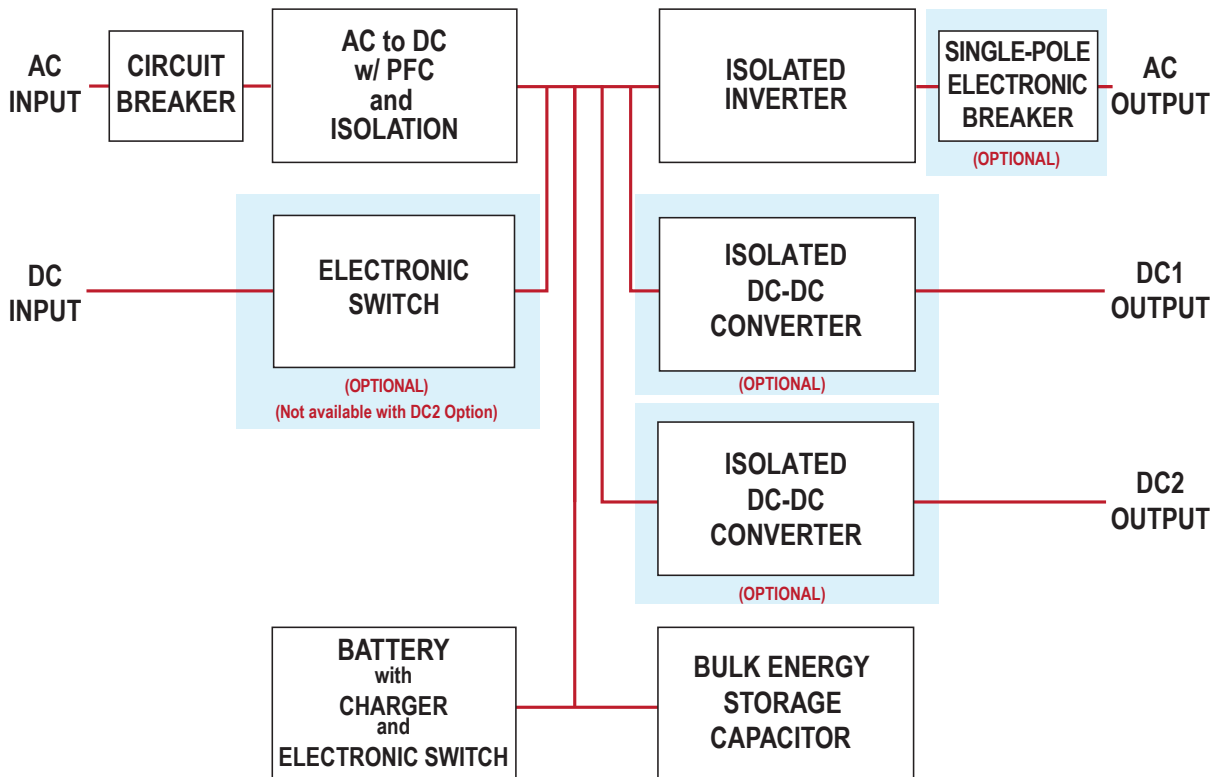

UPS-1500-S-2S

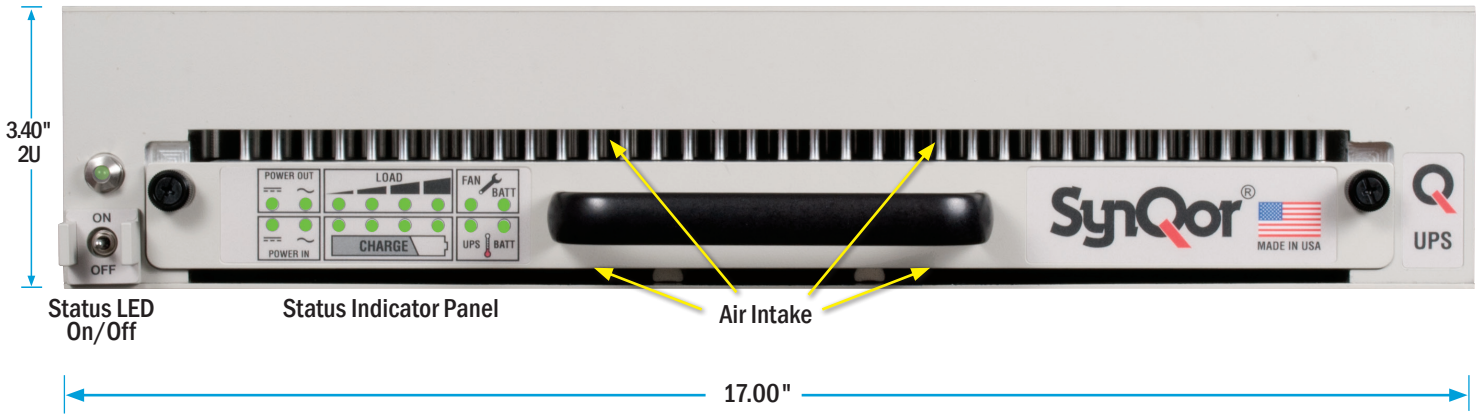

UPS-1500-S-2S WITH DC INPUT / DC1 OUTPUT OPTIONS

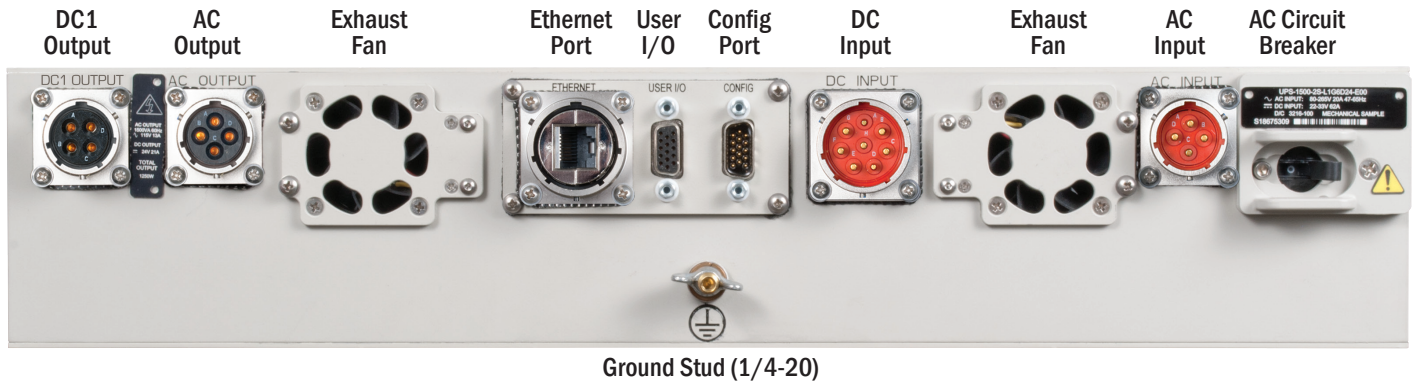

UPS-1500-S-2S WITH DC1 OUTPUT / DC2 OUTPUT OPTION





Power Converters & Systems



SynQor, Inc.

Toll Free (USA): 888-567-9596

E-mail: power@synqor.com

Phone: 978-849-0600

Fax: 978-849-0602

www.SynQor.com