

UPS **MILITARY SHELTER-GRADE**

Uninterruptible Power Supply



Shelter-Grade



Rugged Metal Construction

SynQor[®]

UPS **MILITARY** SHELTER-GRADE *Uninterruptible Power Supply*

SynQor's family of rack-mounted Military Shelter-Grade Uninterruptible Power Supply units are designed for the environmental and electrical conditions of Military applications. SynQor's UPS incorporates proven high efficiency designs and packaging technologies. This UPS will accept a wide range of input voltage and frequency values while delivering a well-conditioned AC output to the load. The use of lithium polymer batteries permits the lowest profile and lowest weight solution in its power class. It is designed to comply with a wide range of military standards.

UPS PRODUCT FEATURES

- ◆ Hot swappable internal battery pack (lithium polymer)
- ◆ >10 minute run-time at full power
- ◆ 1250W (1500VA) output power
- ◆ Full power operation: -10°C to +50°C
- ◆ Universal AC input: 80-265VAC; 47-65Hz
- ◆ Power factor correction at AC input
- ◆ True on-line double conversion
- ◆ Cold-start with no AC input connections
- ◆ Pure sinusoidal AC output voltage
- ◆ Handles 0.0—1.0 power factor loads and non-linear loads
- ◆ User I/O and Configuration signal ports
- ◆ 2U high rack mount unit [16.92"W x 22.13"D x 3.40"(2U)H]
- ◆ Low weight: 42 lbs. (including battery)

SPECIFICATION COMPLIANCE

UPS-MS-1500 units are designed to meet:

- ◆ MIL-STD-461F
 - Electromagnetic Interference
- ◆ MIL-STD-810G
 - Environmental Engineering Considerations
- ◆ Mil-STD-1399-300B
 - Interface Shipboard Systems

IN-LINE MANUFACTURING PROCESS

- ◆ AS9100 and ISO 9001 certified facility
- ◆ Full component traceability

OPTIONS

- ◆ 115Vrms or 230Vrms AC output
- ◆ 50Hz or 60Hz output



Output Options

Base Model				
Model Number	Power	Battery Run-Time@Full Power (80% Power)	Height (W x D x H)	Weight
UPS-MS-1500-S-2U (1 Standard Battery Pack)	1250 W 1500 VA	>10 min. (>13 min.)	2U (16.92" x 22.13" x 3.40")	42 lbs.

Base Models	Options					Options	
	AC Input Freq	AC Output Voltage	AC Output Neutral Wire	AC Output Set Point Freq	Additional Options	AC Input Freq	AC Output Voltage
UPS-MS-1500-S-2U-	L	1 2 3 4	G	5 6	-E 00 CE	L 47-65 Hz	1 115 Vrms 2 230 Vrms - EU 3 230 Vrms - UK 4 230 Vrms - ANZ
						AC Output Neutral Wire	G Grounded
						AC Output Set Point Freq	5 50 Hz 6 60 Hz
						Additional Options	-E Ethernet/SNMP with Configuration Loading 00 No CE Marking CE CE Marking (230 V only)

Not all combinations make valid part numbers, please contact SynQor for availability. See the Product Summary web page for more options.

Examples:

UPS-MS-1500-S-2U-L1G6-E00, UPS-MS-1500-S-2U-L2G5-E00, UPS-MS-1500-S-2U-L2G5-ECE (230 V output with CE marking)

Block Diagram

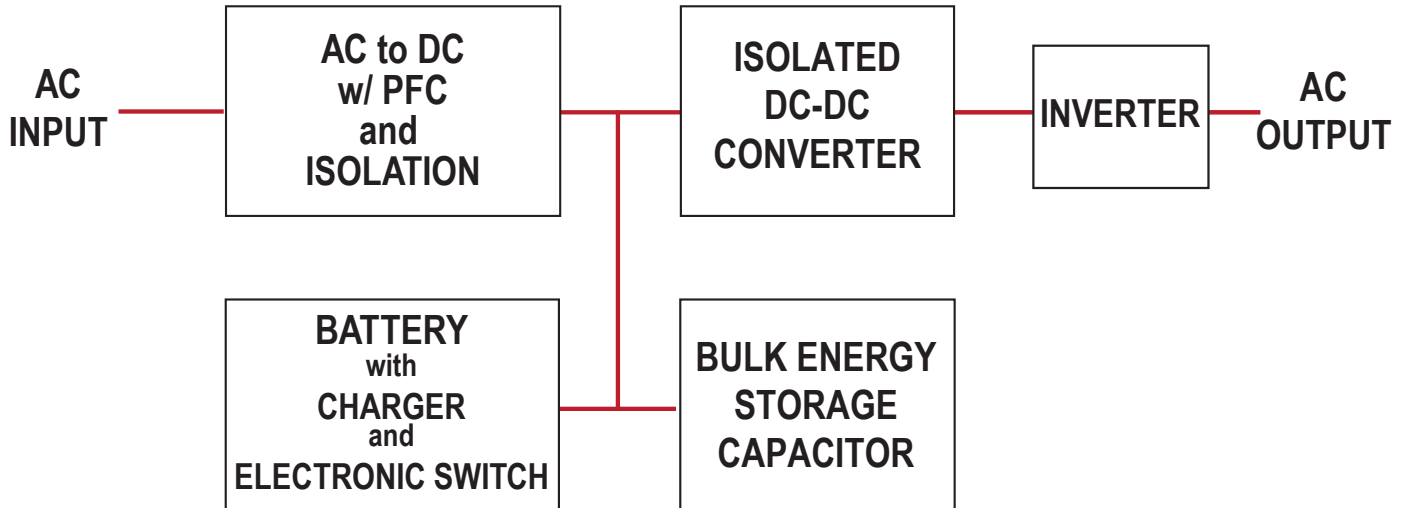

Mechanical diagram

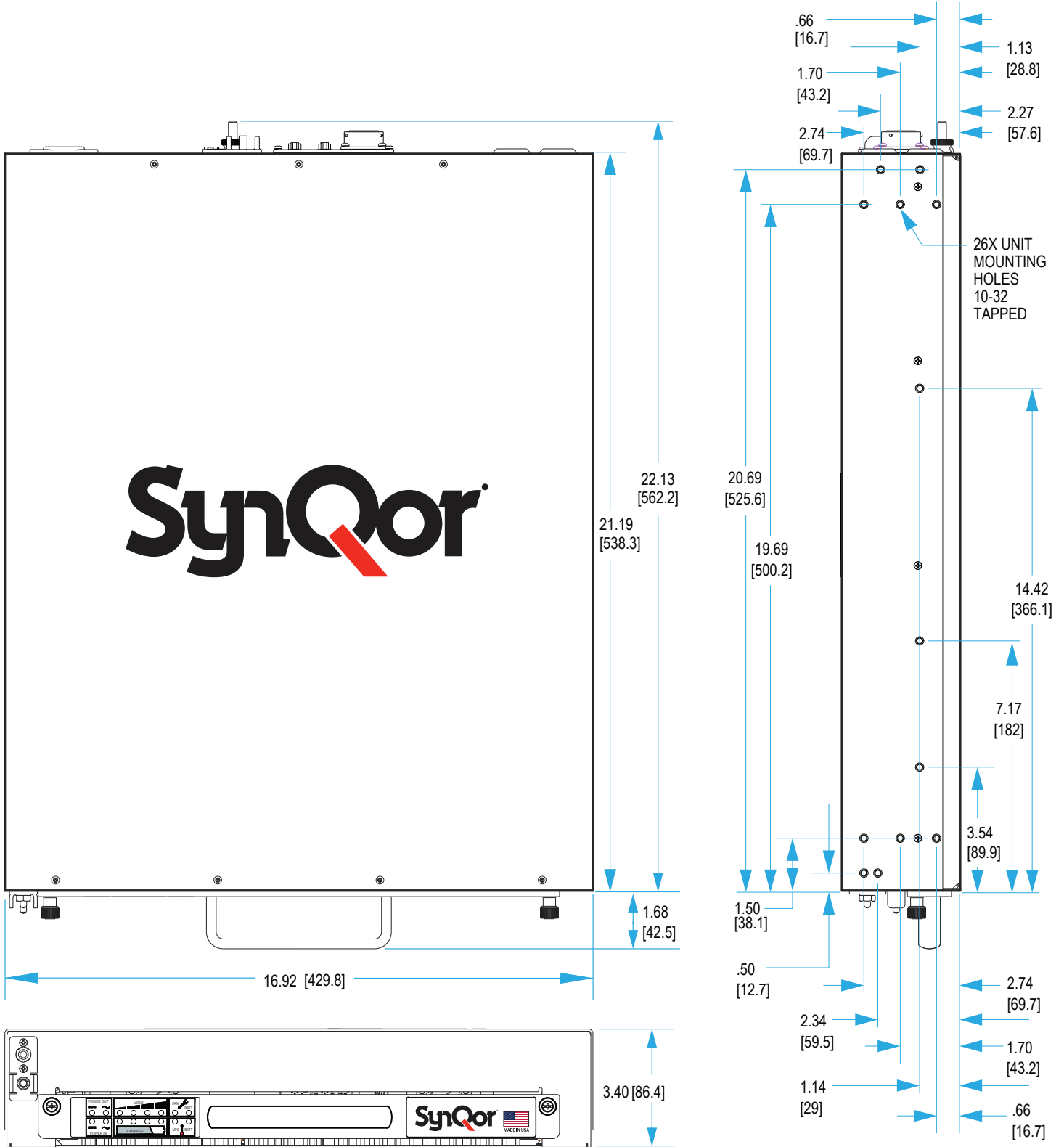

UPS **MILITARY** SHELTER-GRADE **Uninterruptible Power Supply**

UPS-MS-1500

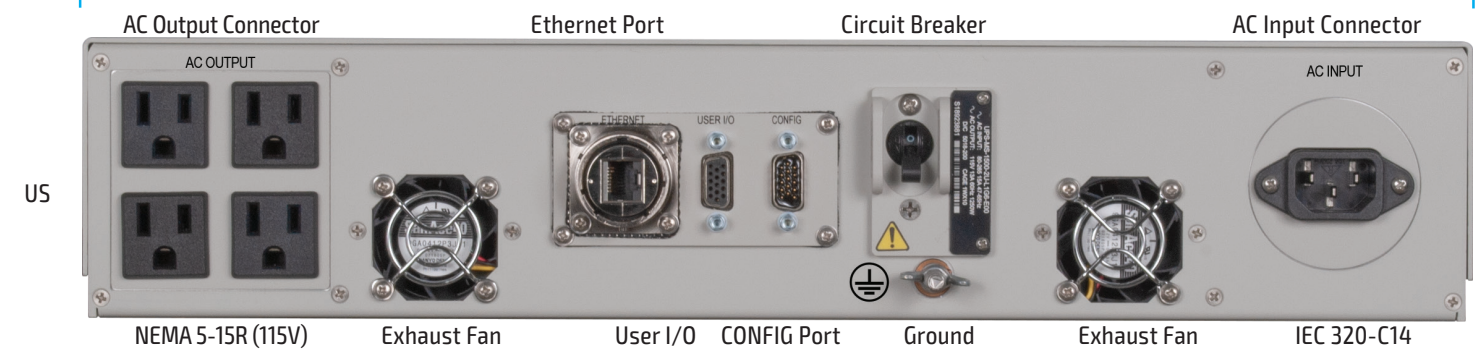
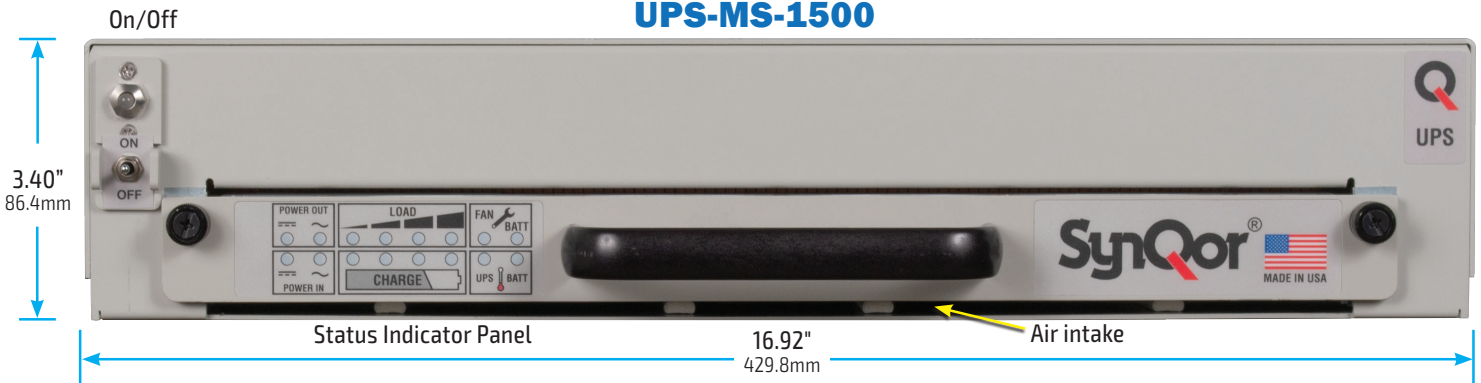



Power Converters & Systems



SynQor, Inc.

Toll Free (USA): 888-567-9596

E-mail: power@synqor.com

Phone: 978-849-0600

Fax: 978-849-0602

www.SynQor.com