

VPX SERIES



Positronic®

THE SCIENCE OF CERTAINTY



VPX Series Features

- Six power contacts
- Three level of sequential mating
- Compatible with IEEE 1101.2 conduction cooled boards
- Compatible with popular high speed data connectors, no notching of the board required
- High reliability large surface area contact system

Compliant to VITA 41 VXS power connector requirements

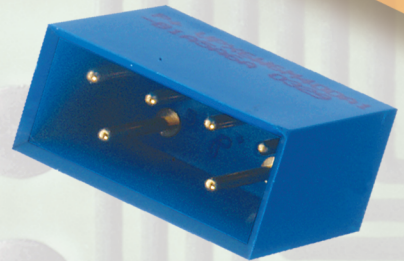
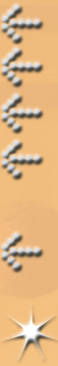

**The dedicated power interface
between plug-in boards and backplanes**

C-035 Rev. D 19/11

Today, some customer applications have requirements for high bandwidth transfer between VMEbus cards. Requirements which even the most updated VME parallel bus cannot support. To meet this need the VITA 41 specification has been developed. VITA 41 VXS (VME Switched Serial) defines a common data plane interconnect using switched serial topologies.

Positronic's VPX power connector was developed to support VITA 41. The VPX series provides a dedicated power interface between boards and backplanes eliminating the need to use valuable high speed contacts to carry power.

The VPX series has a unique package size which allows compatibility with conduction cooled boards per IEEE 1101.2.

A unique size, multiple power contacts, three levels of sequential mating and high reliability make the VPX series suitable for VITA 41 or any similar application.



PICMG and the PICMG logo are registered trademarks of the PCI Industrial Computers Manufacturers Group.

TECHNICAL CHARACTERISTICS

MATERIALS AND FINISHES:

Insulator:	Glass-filled polyester, UL 94V-0, blue color.
Contacts:	Precision-machined copper alloy with gold flash over nickel plate. Other finishes available upon request.

ELECTRICAL CHARACTERISTICS:

Contact Current Ratings, per UL 1977	See temperature rise curve for details.
Size 20 Power Contacts:	24 amperes continuous, all contacts under load.
Initial Contact Resistance:	0.001 ohms maximum, per IEC 60512-2, Test 2b.
Insulation Resistance:	5 G ohms per IEC 60512-2, Test 3a.
Working Voltage:	200 V r.m.s
Creepage and Clearance Distance; minimum:	2.0 mm [.079 inch]

MECHANICAL CHARACTERISTICS:

Blind Mating System:	Male and female connector bodies provide "lead-in" for 1.0 mm [.039 inch] diametral misalignment.
Polarization:	Provided by contact arrangement.
Fixed Contacts:	Printed board terminations. Female contacts feature "Closed Entry" design.
Fixed Contact Retention in Connector Body:	40 N [9 lbs.]
Sequential Contact Mating System*1:	First mate, second mate and third mate contacts available.

*1 Power to be enabled through a last mate contact within VPX Series or another connector. See Sequential Mating Code section on page 4 for more information.

Printed Board Mounting: Mounting holes provided in connector body for printed board. Self-tapping screws are available, see ordering information page.

Mechanical Operations: 250 couplings, minimum.

CLIMATIC CHARACTERISTICS:

Working Temperature: -55°C to +125°C.

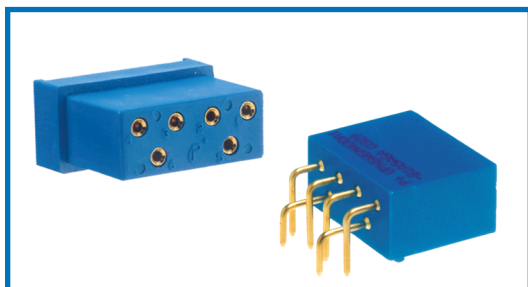

VPX6W6F9300A1 and VPX6W6M400A1



MALE CONNECTOR WITH RIGHT ANGLE (90°) SOLDER TERMINATIONS CODE 4

Typical Part Numbers
VPX6W6M400*

NOTE: *Indicates contact plating options for connectors. See Step 7 of ordering information on page 6.

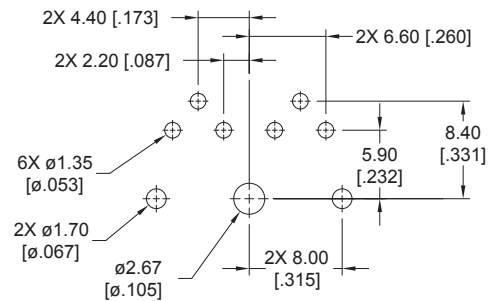
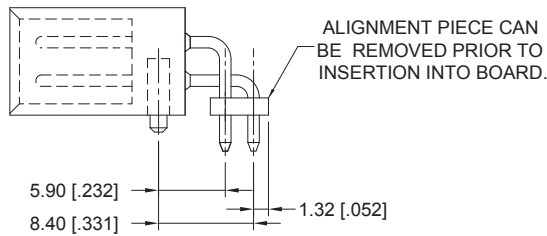
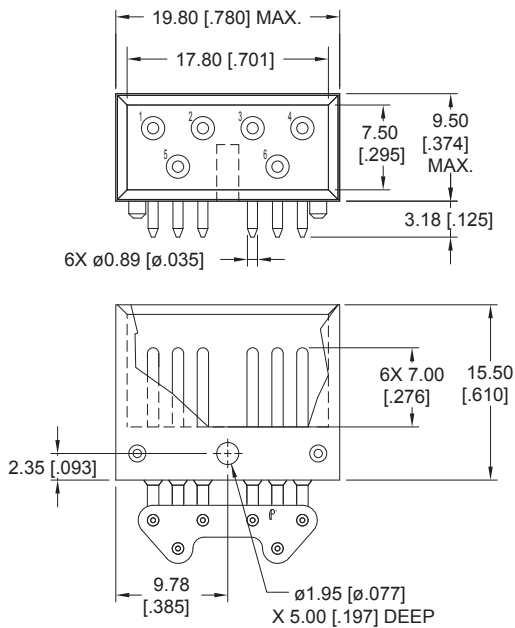

VPX6W6M400A1 shown for reference

CONTACT HOLE PATTERN

FEMALE CONNECTOR WITH COMPLIANT PRESS-FIT TERMINATIONS CODE 93

Typical Part Numbers
VPX6W6F9300*

NOTE: *Indicates contact plating options for connectors. See Step 7 of ordering information on page 6.

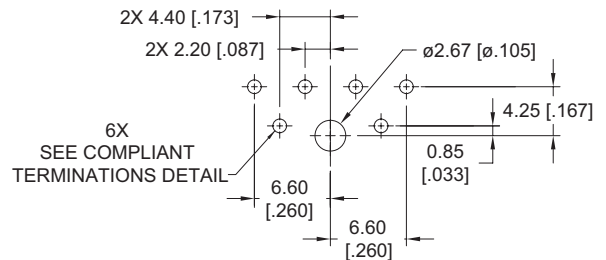
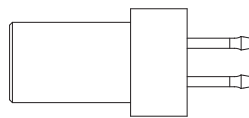
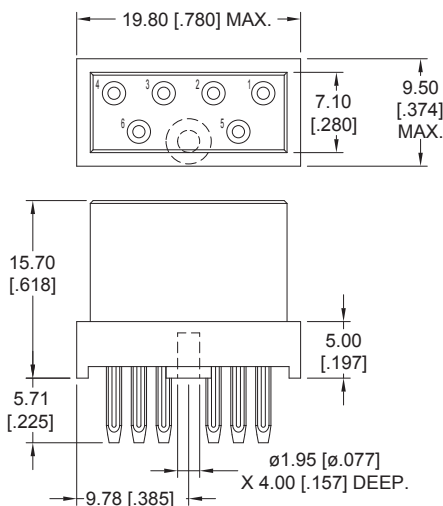

VPX6W6F9300A1 shown for reference

NOTE: Positronic recommends the practice of using mounting screws to secure connector to printed circuit board. Mounting screws **must** be ordered separately. See chart on page 6 for part number.

CONTACT HOLE PATTERN

NOTE: See next page for suggested printed board hole sizes.

SUGGESTED PRINTED BOARD HOLE SIZES FOR COMPLIANT PRESS-FIT CONNECTORS

BI-SPRING COMPLIANT PRESS-FIT CONTACT HOLE				
BOARD TYPE	CONTACT SIZE / TYPE	DRILL HOLE SIZE	RECOMMENDED PLATING	FINISHED HOLE SIZES
TIN-LEAD SOLDER PCB	20 BI-SPRING	---	3 μ [.0001] minimum solder over 25 μ [.0010] min. copper	$\phi 1.19 \pm 0.05$ [$\phi 0.047 \pm .002$]

“Bi-Spring” Termination

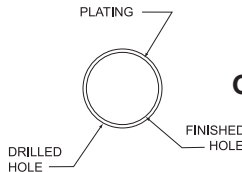

COMPLIANT PRESS-FIT CONTACT HOLE

Note: For PCB plating compositions, i.e. ENIG (Electroless Nickel, Immersion Gold), consult Technical Sales.

SEQUENTIAL MATING CODE

SELECTION GUIDE FOR ORDERING DIFFERENT CONTACT LENGTHS STEP 9 OF ORDERING INFORMATION

SELECT CONNECTOR USING ORDERING INFORMATION ON PAGE 6
THEN CHOOSE STEPS BELOW FOR SEQUENTIAL MATING SYSTEM CONTACTS

STEP	1	2	3	4	5	6	7	8	9
EXAMPLE	A	1	B	2	B	3	C	4	C

STEP 1

Specify code for most frequently used contact mating length. This length is used for all contacts not specified in steps 2 through 9.

STEP 2

Position number for first special length contact.

STEP 3

Length of contact specified in step 2. (Choose from length code chart)

STEP 4

Position number for second special length contact.

STEP 9

Length of contact specified in step 8 (Choose from length code chart).

STEP 8

Position number for fourth special length contact.

STEP 7

Length of contact specified in step 6 (Choose from length code chart).

STEP 6

Position number for third special length contact.

STEP 5

Length of contact specified in step 4 (Choose from length code chart).

CONTACT CODE	CONTACT LENGTH
A	8.50 [.335]
B	7.00 [.276] STANDARD
C	5.50 [.217]

TEMPERATURE RISE CURVE

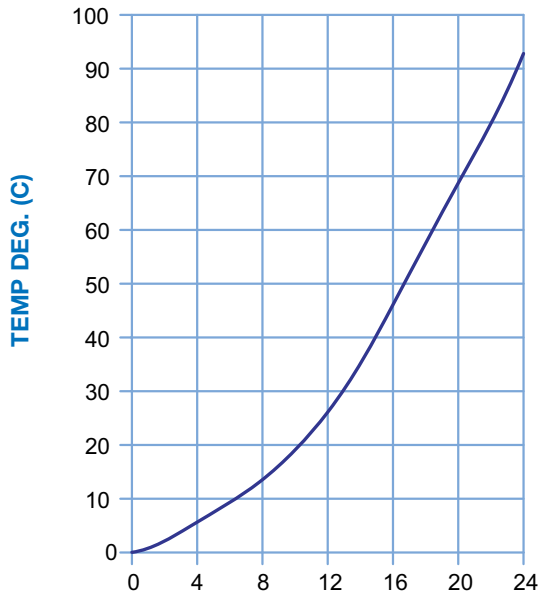

SIZE 20 CONTACT CURRENT LOAD

Temperature curve developed using VPX6W6F9300A1 and VPX6W6M400A1 connectors and 16 AWG wire. All size 20 contacts under load.

MATING DIMENSIONS

Right Angle (90°) Board Mount Male to Straight Board Mount Female (FULLY MATED)

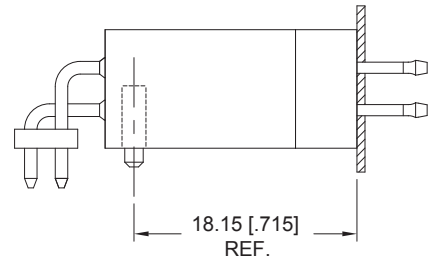

1 mm [.039 inch] separation allowed

APPLICATION FEATURES

FOR ILLUSTRATION ONLY

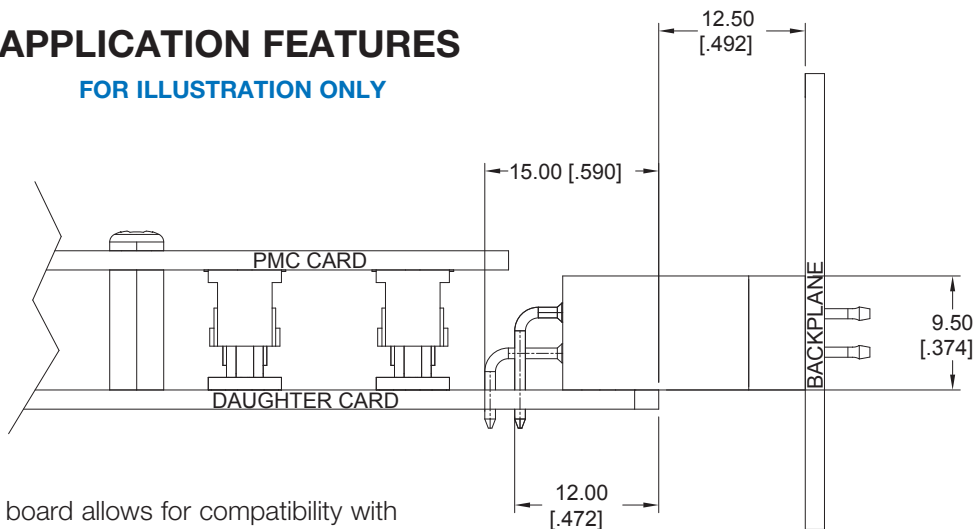

Height above the board allows for compatibility with conduction cooled cards per IEEE 1101.2.

Limited depth into the daughtercard allows compatibility with many popular PMC card configurations. (Alignment piece may need to be removed prior to installation).

Products described within this catalog may be protected by one or more of the following US. patents:

#4,900,261	#5,255,580	#5,329,697	#6,260,268
#6,835,079	#7,115,002	#8,944,697	#9,304,263

Patented in Canada, 1992 Other Patents Pending

Information in this catalog is proprietary to Positronic and its subsidiaries. Positronic believes the data contained herein to be reliable. Since the technical information is given free of charge, the user employs such information at his own discretion and risk. Positronic assumes no responsibility for results obtained or damages incurred from use of such information in whole or in part.

The following trademarks are owned by Positronic Industries, Inc.: Positronic Industries, Inc.®, Positronic®, Connector Excellence®, P+ logo®, PosiBand®, PosiShop®, Optik-D™, and The Science of Certainty®. The color blue as it appears on various connectors is a trademark of Positronic Industries, Inc., Registered in U.S. Patent and Trademark Office.

Positronic Industries' FEDERAL SUPPLY CODE (Cage Code) FOR MANUFACTURERS is 28198

ORDERING INFORMATION - CODE NUMBERING SYSTEM

Specify Complete Connector By Selecting An Option From Step 1 Through 7

STEP	1	2	3	4	5	6	7	8	9
EXAMPLE	VPX	6W6	F	93	0	0	A1	/AA	

STEP 1 - BASIC SERIES
VPX - VP Series

STEP 2 - CONNECTOR VARIANTS
6W6 - All contact positions populated.

STEP 3 - CONNECTOR GENDER
M - Male
F - Female

STEP 4 - TYPE OF CONTACT
4 - Right angle solder, board mount. Male only.
93 - Straight press-fit PCB. Female only.

STEP 5
0 - None

STEP 9 - SPECIAL OPTIONS
Sequential mating system - See page 4 for details.
CONTACT TECHNICAL SALES FOR SPECIAL OPTIONS

STEP 8 - ENVIRONMENTAL COMPLIANCE OPTIONS
/AA - Compliant per EU Directive 2002/95/EC (RoHS)
Note: If compliance to environmental legislation is not required, this step will not be used.
Example: VPX6W6F9300A1

STEP 7 - CONTACT PLATING
A1 - Gold flash over 0.76µm Ni (nominal) over Cu
A2 - Gold flash over 0.76µm Ni (nominal) over Cu, solder coat tails.*1
C1 - 0.76µm Au (min) over 0.76µm Ni (nominal) over Cu
C2 - 0.76µm Au (min) over 0.76µm Ni (nominal) over Cu, solder coat tails.*1
D1 - 1.27µm Au (min) over 1.27µm Ni (min) over Cu
D2 - 1.27µm Au (min) over 1.27µm Ni (min) over Cu, solder coat tails.*1

*1 Not available with code 93 in step 4.

STEP 6
0 - None

- VP Series connectors are **designed to be mounted to the PCB with screws**. Please use the following type: Phillips Pan Head Self-Tapping Screw, 2-28 Triplask II Trilobular threads or equivalent. Screws are available from Positronic. See chart for part number.
- Female contact press-fit connectors **require a press-fit tool**, part number 9513-308-4-41, for installation.

Let us work with you to develop variants of the VP Series to meet your specific requirements.

Unless otherwise specified, dimensional tolerances are:

- ±0.03 mm [.001 inches] for male contact mating diameters.
- ±0.08 mm [.003 inches] for contact termination diameters.
- ±0.13 mm [.005 inches] for all other diameters.
- ±0.38 mm [.015 inches] for all other dimensions.

MOUNTING SCREWS

STEEL SCREW PART NUMBER	STAINLESS STEEL SCREW PART NUMBER	THREAD LENGTH
A4546-7-1-97	A4546-7-6-4	6.35+0.00-0.76 [.250+.000-.030]
A4546-7-2-97	A4546-7-7-4	7.93+0.00-0.76 [.312+.000-.030]
A4546-7-3-97	A4546-7-8-4	9.53+0.00-0.76 [.375+.000-.030]
A4546-7-4-97	A4546-7-9-4	11.11+0.00-0.76 [.438+.000-.030]

Mounting hole in connector is 4.00 [.157] deep.

Contact Technical Sales for RoHS compliant mounting screw information.