

**GLASS-TO-METAL SEAL**

# **HERMETIC CONNECTORS**

**MILITARY QPL AND COMMERCIAL CONNECTORS FOR HARSH ENVIRONMENT AIR-TIGHT-SEAL APPLICATIONS**

APRIL 2013

MISSION  
CRITICAL HIGH  
PRESSURE

# HERMETICS

*Resolve gas, moisture, and particle ingress problems with advanced performance glass-sealed hermetic connectors—the world's largest selection and best availability.*



## Features

- DSCC qualified Mil-DTL-38999 Series I, II, III and IV hermetics in both pin and socket configurations plus QPL MIL-DTL-24308 QPL D-sub miniatures
- MIL-DTL-24308 QPL D-sub miniature hermetics
- Available sealing (helium leak rate) from  $<1 \times 10^{-7}$  cc/sec to  $1 \times 10^{-10}$
- No material breakdown or aging over time
- Matched and compression seal glass-to-metal technologies
- Pressure resistance to 32,000+ PSI
- Stainless steel, titanium, Kovar® and Inconel® shell material options







**G**lenair®

Glenair, Inc.  
1211 Air Way  
Glendale, CA  
91201-2497  
818-247-6000  
sales@glenair.com  
www.glenair.com

# MIL-QPL and Commercial Glass-Sealed Hermetic Connectors



Introduction to  
Hermetic Connectors

<p><b>Introduction to Hermetic Connectors</b></p>		<p><b>A</b></p>
<p><b>MIL-DTL-38999 QPL and Glennair Commercial Hermetic Connectors</b></p>		<p><b>B</b></p>
<p><b>Series 80 Mighty Mouse Hermetic Connectors</b></p>		<p><b>C</b></p>
<p><b>MIL-DTL-26482 Series I and II Type Hermetic Connectors</b></p>		<p><b>D</b></p>
<p><b>MIL-DTL-83723 Series III Type Hermetic Connectors</b></p>		<p><b>E</b></p>
<p><b>MIL-DTL-26500 Type Hermetic Receptacle Connectors</b></p>		<p><b>F</b></p>
<p><b>MIL-DTL-5015 Type Hermetic Connectors</b></p>		<p><b>G</b></p>
<p><b>Series 22 Geo-Marine® Hermetic Connectors</b></p>		<p><b>H</b></p>
<p><b>MIL-DTL-24308 QPL D-Subminiature Hermetic Connectors</b></p>		<p><b>J</b></p>
<p><b>MIL-DTL-83513 Type Micro-D Hermetic Connectors</b></p>		<p><b>K</b></p>
<p><b>Series 79 Micro-Crimp Hermetic Connectors</b></p>		<p><b>L</b></p>
<p><b>Series 970 PowerTrip™ Hermetic Connectors</b></p>		<p><b>M</b></p>
<p><b>Special Hermetic Connectors</b></p>		<p><b>N</b></p>
<p><b>Part Number Index</b></p>		<p><b>Index</b></p>

Dimensions are subject to change without notice





## Introduction to Glenair Hermetic Connector Products

# A Glenair In-House Hermetic Solutions

**H**ermetic connectors are designed for use in harsh application environments. Sensitive photographic, sensor and surveillance equipment mounted in the tactical Unmanned Aerial Vehicle for example, must be able to operate in severe weather conditions, at high altitudes, under extremes of atmospheric pressure and in rapidly changing temperature gradients. Hermetic connector devices interconnecting the vacuum sealed black box equipment are selected for their ability to protect the controlled equipment environment by maintaining an air-tight seal between severe flight conditions and aircraft's sensitive payload.

*Glenair typically specifies stainless steel, titanium or Kovar® for its hermetic products to provide an effective barrier against gas ingress and corrosion caused by dew point condensation. The hermetic sealing prevents damage to sensitive electronic systems.*

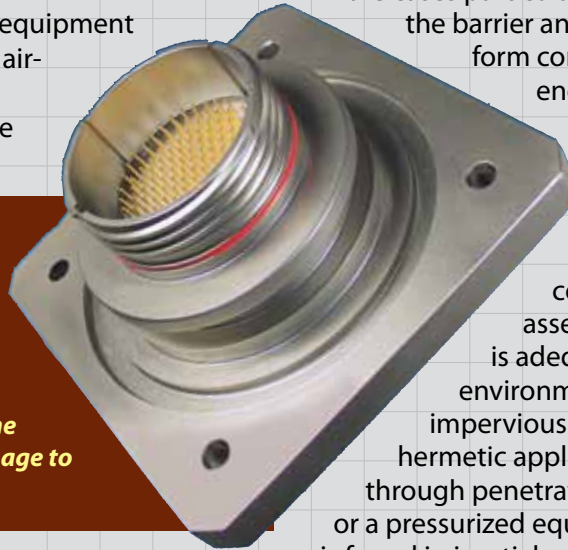

Hermetic connectors are specified for applications as divergent as submarines and orbiting satellites. They are deployed to resist moisture ingress in underground applications and to withstand pressure differentials in vacuum chambers, laboratory equipment and commercial and military aircraft. Hermetic connectors, such as the MIL-DTL-38999 Series I, II, III and IV supplied by Glenair, are principally designed for use in military aerospace—in fact, the requirement for connector hermeticity was originally driven by military electronic applications. But the products are equally at home in commercial applications such as oil-patch

logging equipment or medical devices.

Hermeticity is generally defined as the state or condition of being air or gas tight. In interconnect applications, hermetic refers to packaging technology designed to prevent gasses from passing through pressure barriers via the connector. The reason this is important is to prevent any moisture in the leaked gas from condensing inside the pressurized enclosure. The point at which moisture will condense is called the “dew point”—or the precise moment when humidity, pressure, and temperature allows condensation to form.

When an electric current must pass through a high-pressure differential barrier, the potential exists for gases, moisture, and in some rare cases particulate matter, to also penetrate the barrier and, as described above, to form condensation in the equipment enclosure. In the receptacle cabling on the pressurized side of the barrier this may result in dielectric breakdown, corrosion, and loss of insulation resistance between conductors (a properly built plug assembly on the non-vacuum side is adequately sealed with conventional environmental protections and so is impervious to moisture ingress). The classic hermetic application is a receptacle feed-through penetrating a pressurized bulkhead, or a pressurized equipment housing—such as is found in inertial navigation units in aircraft. The introduction of moisture-laden air into such an enclosure may be enough to produce false readings and other malfunctions in the device. The ultimate purpose of hermetic sealing then is not merely to “avert the ingress of air or gas into pressurized environments to prevent corrosion resulting from dew point condensation,” but more precisely to insure malfunctions do not occur in sensitive electronic systems due to said ingress. Hermetic connectors must perform their magic at extremely high pressure differentials, often as high as 20,000 psi, in order to prevent fluids and high pressure in one area from impacting normal



# Introduction to Glenair Hermetic Connector Products



*The connectors enter the furnace on a conveyor belt and a gas-tight hermetic seal is formed around all contacts, and between the glass seal and the connector shell, when the vitreous glass is melted in the furnace and then cooled under controlled conditions.*

environmental conditions and pressures in another. Hermetic customers may specify the mating connector series, mounting style (jam nut, weld mount, etc.), pin or socket gender and layout, contact termination type (solder cup, flat eyelet or PCB termination), conductive or non-conductive finish, polarization and so on. Glenair customers may also choose from a broad range of contact densities and package sizes, including standard-density MIL-DTL-38999 Series I, II, III and IV, our .76 in. contact spacing Series 80 "Mighty Mouse" Connector, and both Micro-D and D-Subminiature rectangulars. Glenair's complete in-house hermetic capability also affords us the ability to produce a wide-range of special purpose hermetic connectors designed to meet individual and unique customer specifications.

## Connector Hermeticity

Connector Hermeticity may be negatively affected both by the permeability of shell materials and the quality of the sealing technology.

Metal materials are chosen due to their relative impermeability to gas, although certain plastics may also be used. Glenair typically specifies stainless steel, titanium or Kovar® for its hermetic products, as all three base materials provide an effective barrier against gas ingress and are able to withstand the high heat of the fabrication process. But even metal materials are permeable to gas leakage, and their permeability can be compromised when weld and solder joints are formed between connector shell materials and the base material of the bulkhead. Electrode coatings used in welding readily attract moisture in the work which can result in micro-cracks and fissures. If other stresses are present, such as vibration and shock, micro-cracking can progress to fissures which are visible to the human eye. Optimizing hermeticity should therefore always

include examination of welds for any cracks or fissures that could provide a leakage path.

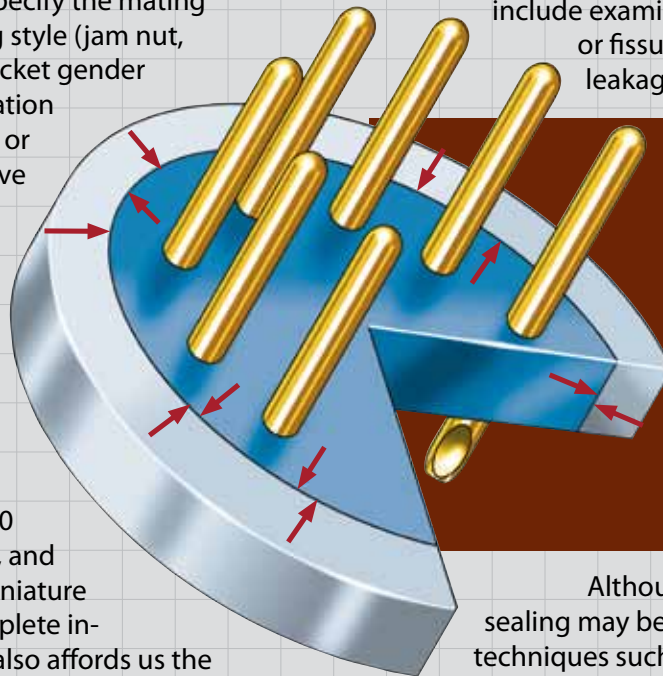

*In Matched Seal hermetics, thermal expansion of the glass and metal materials is relatively small—an important factor in the design of Micro-D hermetic connectors, due to varying degrees of stress on the glass caused by the rectangular shape.*

Although moderately effective sealing may be produced with simple techniques such as epoxy potting, fused glass-to-metal seals are usually specified in high-pressure applications. Glass is an excellent insulator, bonds well to metallic surfaces and is extremely corrosion resistant. And because of its robust mechanical strength and resistance to radical changes in temperature and pressure, glass seals are extremely resistant to any cracking which may introduce leaks into the hermetic package.

Kovar® is a registered trademark of Westinghouse Electric Company.

A

### Series 80 Mighty Mouse Hermetic Connectors



*Series 80 Mighty Mouse Hermetic Mighty Mouse Hermetic Receptacles feature stainless steel shells and Alloy 52 iron alloy contacts. The compression glass seal is rated at  $1 \times 10^{-7}$  cc/second helium leak rate. Coupling styles include double-start stub acme, quick disconnect and bayonet.*

*Receptacles are available in four mounting styles:*

- Solder Mount    ■ Square Flange
- Jam Nut            ■ Weld Mount

#### Technical Specifications

- 3 Through 130 Contacts
- Hermetically Sealed
- 5 Amp Contact for #22 thru #28 Wire
- .076" (1.9) Contact Centers
- 500 Volt AC
- Printed circuit board or solder cup contacts.

Fused glass seals may be produced from various recipes of ground, non-crystalline solids such as silicates, borates and phosphates. When heated to high temperature and then cooled, these materials fuse into an amorphous solid called glass. In hermetic connector manufacturing, the glass material is typically introduced as a pre-formed glass seal insulator tooled to precise dimensions. The glass must be exactly selected for each application according to its ability to form a strong bond with the chosen metal materials.

Electrical properties, such as dielectric withstanding voltage and strength are also considered as is thermal and shock stability. Depending on the style of connector being produced (rectangular versus circular, for example) two categories of glass-seal hermetics may be specified. These are known as Matched and Mismatched (or Compression) Seals.

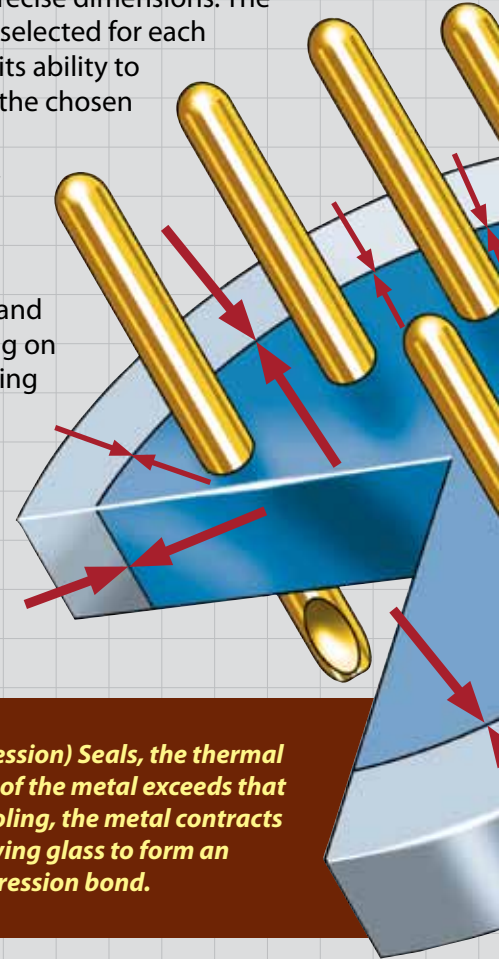

***In Mismatched (Compression) Seals, the thermal expansion/contraction of the metal exceeds that of the glass. During cooling, the metal contracts into the already solidifying glass to form an extremely robust compression bond.***

In Matched Seal hermetics, the thermal expansion of the glass and metal materials are relatively close, usually within 10% of each other. This results in a product in which the stress in the glass is relatively small, since the expansion and contraction of both materials during manufacture is closely matched. This is extremely important in glass hermetic connectors such as the Micro-d since the rectangular shape of the connector shell

## Introduction to Glenair Hermetic Connector Products

**G**lenair®

can exert varying degrees of stress on the glass. At ambient temperatures, the glass is chemically wetted (bonded) to the metal shell and contacts, but under little or no pressure or stress. Matched Seals can withstand high thermal and mechanical shocks, and are generally easier to manufacture than Mismatched (Compression) hermetic seals. Kovar®, a combination of iron, nickel and cobalt, is the material of choice for Matched Seal hermetic receptacles—both shells and contacts. Kovar® is a low-expansion metal with a coefficient of expansion rating matched to the glass material that forms the hermetic seal.

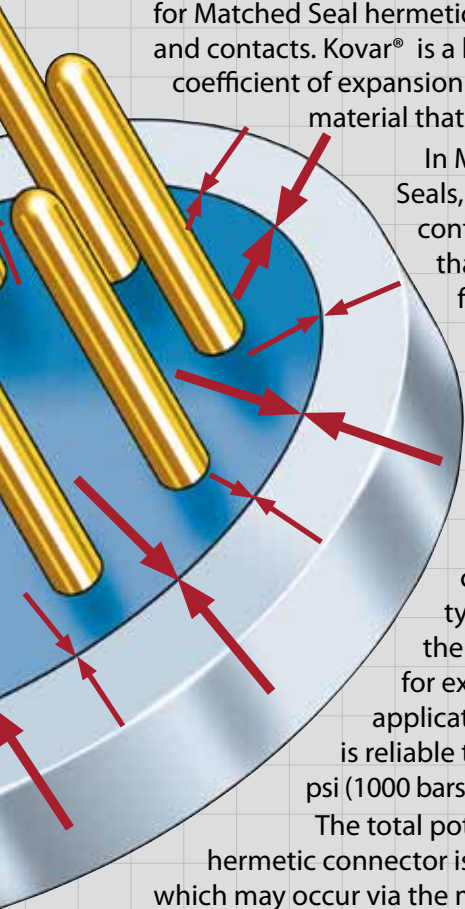

In Mismatched (Compression) Seals, the thermal expansion/contraction of the metal exceeds that of the glass. During the firing process, the metal materials, usually stainless steel, expand at a greater rate than the glass. During cooling, the metals contract back into the already solidifying glass to form an extremely robust compression bond. This type of seal is consequently the most frequently specified for extreme, high-pressure applications since the seal produced is reliable to pressures as high as 14,000 psi (1000 bars).

The total potential for leakage in a hermetic connector is the sum of any permeation which may occur via the metal materials themselves (through cracks or open pores), and any leakage that may occur via the seal. An additional source of leakage—uncontrolled from the connector manufacturer's perspective—results from sub-standard mounting of the hermetic package on the bulkhead or enclosure. Depending on the surface material of the bulkhead, hermetic receptacles may be welded or soldered in place. Low temperature brazing is also possible in certain applications as is the use of adhesive sealants.

### *Mil-Aero Cylindricals:*

**QPL MIL-DTL-38999  
MIL-DTL-26482 Type  
MIL-DTL-83723 Type  
Hermetic Connectors**



*Various styles of standard and high-density cylindrical connectors are manufactured using glass seal hermetic technology. These hermetic connectors are ideally suited for high-pressure/low leakage applications in air, sea and space environments. Glenair is on the Qualified Product List (QPL) for all families of MIL-DTL-38999 Series I, II, III and IV Hermetic Connectors. We also offer lower density cylindrical connectors from the MIL-DTL-26482 and MIL-DTL-83723 families. The latter two series are non-QPL products.*

- DSCC Approved MIL-DTL-38999
- Compression Glass Seals
- Alloy 52 Gold-Plated Contacts
- Four Coupling Styles: Scoop-Proof Bayonet, Low-Profile Bayonet, Triple-Start Threaded Coupling, and Scoop-Proof Breach Coupling
- Fluorosilicone Interfacial Seals
- Passivated and Nickel-Plated SS Shells





## Introduction to Glenair Hermetic Connector Products

A

### MIL-DTL-5015 Type "H" Class Hermetic Connectors



*Considered the "Granddaddy" of all connector specifications, MIL-DTL-5015 covers power connectors available in contact sizes ranging from #16 up to #0. Operating voltages range from 200 up to 3000 volts AC (rms).*

*Currently there is not a Qualified Parts List (QPL) with Defense Supply Center Columbus (DSCC) for the MIL-DTL-5015 hermetic product. However, Glenair has designed and tooled these products to meet or exceed the current Mil-Spec requirements.*

#### Features:

- Box Mount and Solder Mount
- Shell sizes 8 through 36
- CRS with Fused Tin plating or stainless steel with a Passivate finish
- All appropriate contacts in solder cup and pierced contact styles
- Supplied with a bonded interfacial seal to improve moisture resistance
- Custom configurations available
- Commercial equivalents available

Finally, mechanical mounting seals such as O-rings found on jam-nut mounts or drilled mounting flanges are used in applications where the cost or difficulty of welding or soldering is impractical. Regardless of the choice of mounting technology, care must be given to ensure inadvertent leakage paths are not introduced to the system. Vapor condensation in pressurized enclosures may also be affected by the material makeup of devices located inside the enclosure. Materials such as silicones, adhesives, lubricants and Teflon insulation can all outgas water vapor, and so contribute to the total vapor pressure inside the housing. As discussed above, this rise in vapor pressure will directly impact the condensation dew point of the protected environment.

Hermetic seals are qualified via various methodologies including helium testing and dye penetrant. The purpose of both types of tests is to detect and measure leakage under pressure. The dye penetrant method has the advantage of revealing the exact location of a full-scale leak, while helium testing measures overall leakage of the hermetic device. In helium testing, a pressure differential between the internal volume of the package and the external environment is created. The resultant pressure gradient causes the helium to diffuse through the connector shell, contacts and/or glass seals. Quantitative and qualitative measurements are then taken using appropriate sensing instruments.

### Manufacturing Capability

Hermetic connectors are constructed from a core component-set that includes the connector shell, the vitreous glass insert and the selected contacts. Matched hermetic shells may be machined from Kovar<sup>®</sup>, an iron-nickel-cobalt alloy with a coefficient of expansion closely balanced to the glass inserts. Stainless and cold-rolled steels with 52 nickel-alloy contacts are suitable for compression-seal hermetics. Contacts used in hermetic connectors must be fabricated from Kovar<sup>®</sup> or from other high-grade materials that can withstand high-heat and bond effectively to the vitreous glass seal.

## Introduction to Glenair Hermetic Connector Products



The individual parts are mounted into special fixtures that align them during the exothermic atmosphere firing process. A conveyor belt transports the work through the furnace chamber, where a reducing atmosphere prevents oxidation of the metal components. As discussed above, a gas-tight hermetic seal is formed around all contacts and the glass seal and connector shell when the vitreous glass is melted in the furnace and then cooled under controlled conditions. After firing, helium testing and finish plating are completed and the remaining connector components such as interfacial seals, O-rings, jam-nuts and so on are assembled to the connector body.

Quality control is a critical step in hermetic connector manufacturing. Connectors are not only subjected to a rigorous leak test, but are also visually inspected to ensure all components are seated in their correct positions and no surface imperfections or micro-cracking is evident. The connectors are also subjected to electrical testing as required by military and industry standards and by customer requirements.

Dating back to our first hermetic order, Glenair has been in the hermetic connector business for over 30 years. Today, our capabilities are an arm and a leg greater than they once were, but our commitment to high-quality and outstanding availability has remained constant. As you can see from the wide range of commercial and military standard hermetic products we now produce, Glenair is positioned to service an incredibly broad range of both commercial and military standard hermetic packaging requirements.

***Glenair now offers shells in Inconel® and Titanium; built to meet the demands of extreme pressure differentials and corrosion resistance. Consult the factory for product ordering information.***

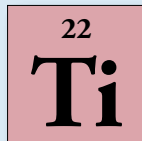

## MIL-DTL-24308/9 QPL D-Subminiature Hermetic Connectors

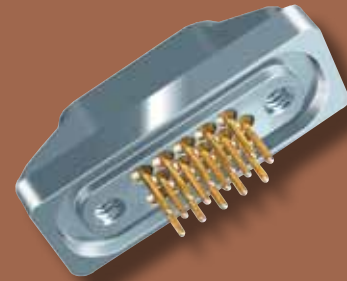

*These hermetically sealed connectors are specifically designed for applications where conditions of extreme pressure differentials exist, or where an inert gas atmosphere must be maintained.*

*Glenair is currently qualified for the MIL-DTL-24308/9 -1 through 20 as well as for the Space Grade class, M24308/9-21 through 40.*

### **Features:**

- One-piece machined shell for both the Solid Flange Mount (Type A) and Jackpost Mount (Type B) configurations
- Shell sizes 1 through 5
- CRS with Fused Tin plating, "H" Class, stainless steel with a matte nickel finish ("K" Class), or Aluminum Alloy Electroless Nickel w/ Hermetic Epoxy Seal
- Space Grade Versions
- All appropriate contacts in solder cup or pierced contact styles
- Many custom configurations available



## Introduction to Glenair Hermetic Connector Products

A

### *Micro-D* O-Ring Sealed and Weld Mount Hermetic Receptacles



*These high contact density hermetic connectors feature .050 inch contact spacing, rugged construction for demanding applications and glass hermetic sealing for severe environmental and pressure differential operating conditions. Designed for use in missile systems and other high altitude aerospace applications, Glenair's Micro-D Hermetic Connectors offer outstanding performance in a lightweight microminiature package. The two basic mounting configurations, a weld-mount or O-ring mount design may be customized for unique application requirements.*

#### **Features:**

- Socket Receptacles
- Matched, Glass to Metal Seals,
- 1,000 PSI
- 9 through 100 Contacts
- Weld, O-Ring or Solder Mount;  
Integral Jackposts
- 1.5 AMP; 150 Volt AC
- Solder Cup (#26 Gage Wire), PC Tails,  
and Special Contacts for Wire Bonding

## Hermetic Glossary

### **Air Leakage**

The measure of gas ingress across an hermetic barrier. Total air leakage is the sum of the gas which passes through the seal itself, the permeable shell materials or via cracks or gaps in the mounting area.

### **Bonding**

In hermetic glass-to-metal sealing, the permanent fusing of the constituent connector parts —contacts, connector body and glass seal—to one another using surface preparation techniques and high-heat.

### **Coefficient of Expansion**

A mathematically derived value describing the dimensional change of a material when subjected to a measured change in temperature. Factored into hermetic connector fabrication to insure the glass and metal materials return to a known state of compression after the heating and cooling process is completed.

### **Compression Seal**

The most effective glass-to-metal sealing. It is created by using metal shell and contact materials which expand at a greater rate than the glass during heating. During cooling, the metal materials contract back into the already solidifying glass to form a robust compression bond.

### **Environmentally Sealed**

A class of interconnect components which are sealed against moisture ingress through the use of gaskets, O-rings, grommets or other means. Many applications that could use costlier hermetically-sealed connectors can be adequately protected using simpler environmental sealing techniques. The decision to use hermetics is generally made when the ability to withstand high-pressure differentials (32psi and up) is added to the application performance specifications.

### **Feedthrough**

A double-sided receptacle connector device, mounted in a bulkhead or wall, used in interconnect



## Introduction to Glenair Hermetic Connector Products



systems to pass wires through barriers without creating an entry point for moisture, dust or chemical pollutants. Hermetic feedthrough connectors are used when the compartments on either side of a bulkhead must be maintained at different pressure levels.

### Flange

Disc-shaped projection extending from or around the periphery of a receptacle connector designed to house O-ring sealing devices, fasteners or other mounting hardware. A flange may also be used to provide a greater surface area of metal material to aid in weld or solder mount attachment of receptacle connectors to bulkheads.

### Hermeticity

The measure of a connector's permeability to gas ingress. In general terms, it means how "airtight" the device is when measured using a helium mass spectrometer leakage test. Since all materials are ultimately permeable to gas ingress at some point, hermeticity ratings are used to define acceptable performance levels as required by each individual application.

### Hermetic Connector

Any of various forms of interconnect devices which are outfitted with specialized seals to prevent moisture and gas from passing through the connector and damaging sensitive electronic equipment. Glass sealed hermetic connectors are the most effective, with compression-glass sealed connectors providing the highest levels of protection.

### Kovar®

An iron-nickel-cobalt alloy with a coefficient of expansion closely matched to certain glass seals commonly used in both connector bodies and contacts.

### Matched Seal

A category of glass-to-metal sealing. In matched seals, the coefficient of expansion for the glass seal, contacts and connector body are relatively the same, resulting in a finished product with little or no built-in stress between the constituent parts.

### Mismatched Seal

Also known as compression sealing, the different material coefficient of expansion values in the glass and metal materials result in an hermetic seal that is under significant compression stress after cooling. Hermetics of this type can withstand higher-pressure differentials than matched seals.

### Solder or Weld Mount

One of the most common mounting configurations for hermetic connectors, especially for electronic equipment such as switches and transducers. Unlike jam-nut mounted connectors, weld mount hermetics are permanently attached to the pressurized bulkhead, typically with laser, TIG or MIG welding technology.

## Series 22 Geo-Marine® Hermetic Connectors



*Series 22 Geo-Marine® Connectors offer high-density insert arrangements for a variety of oceanographic, geophysical and other severe commercial applications. The mated stainless steel plug and receptacle have a hydrostatic pressure sealing capability of up to 5000 psi (345 bar) and are available in either glass-seal hermetic or rigid dielectric environmental insulators.*

- Single-start, stub-Acme thread reduces thread fouling and binding due to dirt, grit and other foreign matter. Castellated and knurled coupling ring provides easy mating and unmating—even with arctic gloves.



## Glenair Hermetic Connector Products Space Grade Modification Codes

A

### What is outgassing?

Plastic and rubber materials give off gaseous molecules. For example, the smell inside a new car is caused by polymer outgassing. Heat and vacuum increase the rate of diffusion. In a spacecraft the gases coming off polymers can contaminate optical surfaces and instruments. The result is degraded performance.

### How is outgassing measured?

The space industry has adopted a standardized test procedure, *ASTM E 595*, to evaluate out-gassing properties of polymers. Small samples of material are heated to 125° C. at a vacuum of  $5 \times 10^{-5}$  torr for 24 hours. Then the sample is weighed to calculate the **Total Mass Loss** (TML). The TML cannot exceed 1.00% of the total initial mass. During the test, outgassed matter condenses on a cooled collector plate. The quantity of outgassed matter is calculated to determine the **Collected Volatile Condensable Material** (CVCM). The CVCM cannot exceed 0.10% of the original specimen mass.

### What is NASA screening?

NASA specification EEE-INST-002 provides instructions on selecting, screening and qualifying parts for use on NASA GSFC space flight projects.

### What screening level is required?

NASA defines three levels of screening: level 1 for highest reliability, level 2 for high reliability, and level 3 for standard reliability. Level 3 equates to standard lot acceptance inspection. Levels 1 and 2 call for additional testing.

## HOW TO ORDER SPACE GRADE CONNECTORS

### Step 1: Find a Standard Part Number

Electroless nickel plated shells are preferred for space flight. Cadmium plating is prohibited.

### Step 2: Select a NASA Screening Level

The term "Screening Level" refers to the final inspection procedure.

**Level 1** for mission-critical highest reliability

**Level 2** for high reliability

**Level 3** for standard reliability

### Step 3: Choose Outgassing Processing

A detailed explanation of outgassing is on the following pages. The fluorosilicone rubber seals commonly used on aerospace-grade connectors such as MIL-DTL-38999 and Series 79 connectors, along with certain bonding agents and inks, do not meet NASA outgassing requirements unless the connector is specially processed. Glenair outgassing tests have shown oven baking or thermal vacuum outgassing processing are sufficient to reduce outgassing levels to NASA standards. Oven baking is more economical than thermal vacuum outgassing.

### Step 4: Select the Mod 429 Code that Matches the Desired Level of Screening and Outgassing

Use the following table to choose the right modification code. Add the mod code to the connector part number. Example: 790-024PC-13ML-**429C**

## NASA SCREENING LEVELS AND MODIFICATION CODES

NASA Screening Level	Special Screening Only	Special Screening Plus Outgassing Processing	
		48 Hour Oven Bake 175° C.	Thermal Vacuum Outgassing 24 hrs. 125° C.
Level 1 Highest Reliability	Mod 429B	Mod 429J	Mod 429C
Level 2 High Reliability	Mod 429	Mod 429K	Mod 429A
Level 3 Standard Reliability	(Use standard part number)	Mod 186	Mod 186M

# Glenair Hermetic Connector Products Special Leak Rate Modification Codes

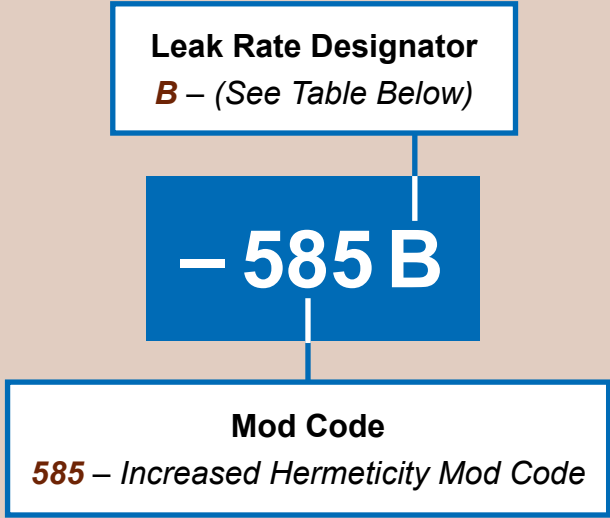

## What is the -585 Mod Code?

Glenair offers an array of hermetic connectors with more stringent leak rate requirements. By adding “-585” and the designator letter “A”, “B” or “C”—depending on the hermeticity desired—to the end of a standard part number, connectors will be built to exceed the standard  $1 \times 10^{-7}$  cc Helium per second leak rate specified on most Glenair hermetics.

### HERMETIC LEAK RATE MOD CODES

Designator	Required Leak Rate
<b>A</b>	$1 \times 10^{-10}$ cc's Helium per second
<b>B</b>	$1 \times 10^{-9}$ cc's Helium per second
<b>C</b>	$1 \times 10^{-8}$ cc's Helium per second

### Catalog Notes

- For all parts in this catalog:
- All parts will be identified with manufacturer's name and part number, space permitting.
  - Glenair 600 series backshell assembly tools are recommended for assembly and installation.
  - Dimensions are subject to change without notice. Metric dimensions appear in parentheses in diagrams and tables, based on 1 inch = 25.4 mm, for reference only. Unless otherwise specified, the following other dimensional tolerances apply:
    - .xx = ± .03 (0.8)
    - .xxx = ± .015 (0.4)
    - Lengths = ± .060 (1.52)
    - Angles = ± 5°

Customers are advised to consult the factory for the latest specifications, particularly to confirm critical dimensions such as connector lengths, threads, and so on. When errors or mistakes are brought to our attention, corrected content is posted immediately to [www.glenair.com](http://www.glenair.com).



## A Hermeticity

Hermeticity is defined as "the state or condition of being airtight". Sophisticated military electronics enclosures can experience electrical failure from ingress of moisture. System engineers can design the enclosure to withstand exposure to moisture and condensation by using "moisture-hardened" components and conformal coatings, but often the most practical approach is to install hermetically sealed electrical I/O connectors. Glass-to-metal seals provide assurance that, over the life of the enclosure, the accumulated amount of water vapor inside the box will not exceed the amount necessary to form condensation. Other applications for Micro-D hermetic connectors include vacuum chambers, cryogenics, and enclosures filled with inert gas.

### Hermetic Testing

All hermetic connectors are 100% tested prior to shipment. A helium leak test is performed to certify the hermetic seal. This test is conducted by inducing a 1 ATM vacuum on one side of the connector. Helium gas is released on the other side, and a mass spectrometer "counts" the number of helium molecules that penetrate the connector seal. Helium leak testing takes advantage of the small size of a helium molecule compared to air or water vapor. Helium is inert, rare in our atmosphere, and is easy to detect with a mass spectrometer.

### Helium Leak Rates

Std cc/sec Approximate	Approximate Bubble Equivalent
$1 \times 10^{-1}$	1 cc/10 sec
$1 \times 10^{-2}$	1 cc/100 sec
$1 \times 10^{-3}$	3 cc/hour
$1 \times 10^{-4}$	1 cc/3 hours
$1 \times 10^{-5}$	1 cc/24 hours
$1 \times 10^{-6}$	1 cc/2 weeks
$1 \times 10^{-7}$	3 cc/year
$1 \times 10^{-8}$	1 cc/3 year
$1 \times 10^{-9}$	1 cc/30 years
$1 \times 10^{-11}$	1 cc/3000 years

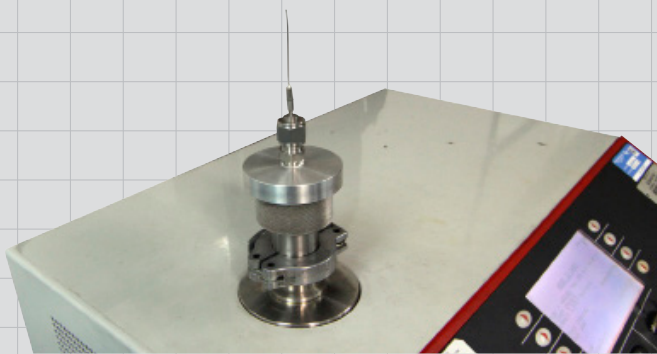
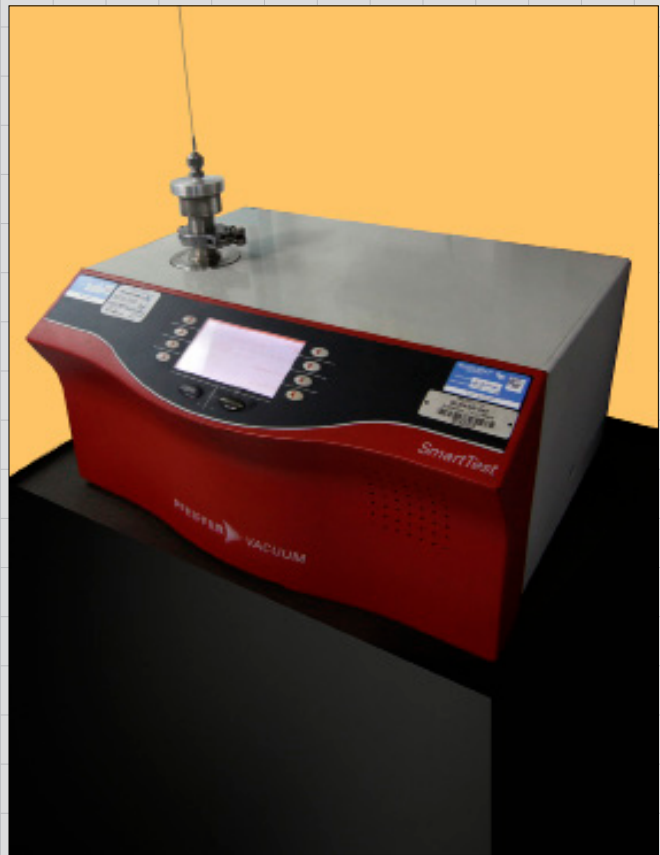

Close up of gas tube assembly undergoing helium leak test at the Glenair Factory in Glendale, CA

# Hermetic Connector Designer's Application Checklist



Name \_\_\_\_\_

Company Name \_\_\_\_\_

Address \_\_\_\_\_

City and State \_\_\_\_\_

Country and Postal Code/Zip \_\_\_\_\_

Telephone \_\_\_\_\_

E-mail \_\_\_\_\_

### Specification Reference:

- |  |   |
|--|---|
| <input type="checkbox"/> MIL-DTL-38999 | <input type="checkbox"/> MIL-DTL-83513                      |
| <input type="checkbox"/> MIL-DTL-5015  | <input type="checkbox"/> MIL-DTL-24308                      |
| <input type="checkbox"/> MIL-DTL-26482 | <input type="checkbox"/> Glenair Series 80                  |
| <input type="checkbox"/> MIL-DTL-83723 | <input type="checkbox"/> Other (i.e. Series 79, Geo-Marine) |

### Shell Style:

- |                                       |  |
|---------------------------------------|--|
| <input type="checkbox"/> Jam Nut      | <input type="checkbox"/> Flange Mount      |
| <input type="checkbox"/> Box Mount    | <input type="checkbox"/> Dual Flange PCB   |
| <input type="checkbox"/> Solder Mount | <input type="checkbox"/> Wall Mount        |
| <input type="checkbox"/> Weld Mount   | <input type="checkbox"/> Connector Adaptor |

Shell Size/Insert Arrangement: \_\_\_\_\_

Pin Count: \_\_\_\_\_

### Contact Gender:

- Pin  
 Socket

Shell Rotation/Clocking Position: \_\_\_\_\_

Shell Material and Finish: \_\_\_\_\_

Termination (PC tails, Solder Cup, Radius, Eyelet, etc.): \_\_\_\_\_  
\_\_\_\_\_  
\_\_\_\_\_

Pressure Requirement (PSI): \_\_\_\_\_

Temperature Requirement: \_\_\_\_\_

Hermeticity Requirement (1x10<sup>-\*</sup> Cc/he) \_\_\_\_\_

IR: \_\_\_\_\_ DWV: \_\_\_\_\_

Marking: \_\_\_\_\_

Connector Application: \_\_\_\_\_

QPL Req'd: Yes \_\_\_\_\_ No \_\_\_\_\_

What material(s) will the connector be in contact with, i.e, fluid, steam, mating connector material:

\_\_\_\_\_  
\_\_\_\_\_  
\_\_\_\_\_

### Special Instructions/Notes:

\_\_\_\_\_  
\_\_\_\_\_  
\_\_\_\_\_  
\_\_\_\_\_

Note: Connectors can be NASA screened, outgassed or be rated for higher hermeticity. Titanium and Inconel® materials additionally are available as well as thermocouple contacts, quadrax, and co-ax contacts.

# MIL-DTL-38999 Series I, II, III, and IV QPL Hermetic Connectors



## Mil Qualified D38999 Series I, II, III and IV Hermetic Receptacles—Pin and Socket— Plus Glenair Commercial Equivalents • Built-In Maximim Design Flexibility

Quick Selection Guide		
Part number	Description	Page
	MIL-DTL-38999 Series I, II, III and IV Hermetic Class Insert Arrangements	B-2 – B-3
	MIL-DTL-38999 Series I, II, III and IV Hermetic Class Layouts and Pin Counts	B-4
	MIL-DTL-38999 Hermetic Class Material Specifications and Finishes	B-5
	MIL-DTL-38999 Connector Performance Specifications	B-6 – B-8
	MIL-DTL-38999 Contact Performance Specifications	B-9
	MIL-DTL-38999 Series I – IV Alternate Keyway Positions	B-10 – B-12
	Recommended Torque Values	B-13
	MIL-DTL-38999 Hermetic Connectors and Environmental Mates	B-14 – B-15
<a href="#">MS27469 / 231-100-H0</a>	Wall Mount Hermetic Receptacle, Series I	B-16 – B-17
<a href="#">MS27470 / 231-100-H7</a>	Jam Nut Mount Hermetic Receptacle, Series I	B-18 – B-19
<a href="#">MS27471 / 231-100-H5</a>	Solder Mount Hermetic Receptacle, Series I	B-20 – B-21
<a href="#">231-103-H7</a>	Jam Nut Mount Hermetic Bulkhead Feed-Thru, Series I	B-22 – B-23
<a href="#">231-103-H9</a>	Sav-Con® Jam Nut Mount Bulkhead Feed-Thru, Series I	B-24 – B-25
<a href="#">257-255</a>	Jam Nut Mount Hermetic Receptacle, Series I	B-26 – B-27
<a href="#">947-117</a>	Jam Nut Mount Hermetic Bulkhead Feed-Thru, Series I	B-28 – B-29
<a href="#">MS27475 / 232-100-H0</a>	Wall Mount Hermetic Receptacle, Series II	B-30 – B-31
<a href="#">MS27476 / 232-100-H2</a>	Box Mount Hermetic Receptacle, Series II	B-32 – B-33
<a href="#">MS27477 / 232-100-H7</a>	Jam-Nut Mount Hermetic Receptacle, Series II	B-34 – B-35
<a href="#">MS27478 / 232-100-H5</a>	Solder Mount Hermetic Receptacle, Series II	B-36 – B-37
<a href="#">232-103-H7</a>	Jam Nut Mount Hermetic Bulkhead Feedthrough, Series II Type	B-38 – B-39
<a href="#">232-103-H9</a>	"Sav-Con"® Connector Saver Jam Nut Mount Hermetic Bulkhead Feedthrough, Series II Type	B-40 – B-41
<a href="#">237-280</a>	Special Weld-Mount Hermetic Receptacle, Series II	B-42 – B-43
<a href="#">947-120</a>	Jam Nut Mount Hermetic Bulkhead Feed-Thru, Series II	B-44 – B-45
<a href="#">947-278</a>	Jam Nut Mount Hermetic Bulkhead Feed-Thru	B-46 – B-47
<a href="#">D38999/21 / 233-100-H2</a>	Box Mount Hermetic Receptacle, Series III	B-48 – B-49
<a href="#">D38999/23 / 233-100-H7</a>	Jam Nut Mount Hermetic Receptacle, Series III	B-50 – B-51
<a href="#">D38999/25 / 233-100-H5</a>	Solder Mount Hermetic Receptacle, Series III	B-52 – B-53
<a href="#">D38999/27 / 233-100-H8</a>	Weld Mount Hermetic Receptacle, Series III	B-54 – B-55
<a href="#">233-103-H7</a>	Jam Nut Mount Hermetic Bulkhead Feed-Thru, Series III	B-56
<a href="#">233-103-H9</a>	Jam Nut Mount Hermetic Plug/Receptacle Bulkhead Feed-Thru, Series III	B-57
<a href="#">237-033</a>	Jam Nut Mount Hermetic with Double O-Rings, Series III	B-58 – B-59
<a href="#">237-063</a>	Special Hermetic Jam Nut Mount Receptacle, Series III	B-60 – B-61
<a href="#">237-153</a>	Hermetic Dual Flange Jam Nut Mount Receptacle, Series III	B-62 – B-63
<a href="#">257-093</a>	Jam Nut Mount Hermetic Bulkhead Feed-Thru, Series III	B-64 – B-65
<a href="#">257-121</a>	Special Jam Nut Mount Hermetic Receptacle with Accessory Threads, Series III	B-66 – B-67
<a href="#">257-215</a>	Jam Nut Mount Hermetic Bulkhead Feed-Thru w/ Crimp Removable Contacts, Series III	B-68 – B-69
<a href="#">257-216</a>	Jam Nut Mount Hermetic Bulkhead Feed-Thru w/ Crimp Removable Contacts, Series III	B-70 – B-71
<a href="#">257-288</a>	Box Mount Hermetic Bulkhead Feed-Thru w/ Crimp Removable Contacts, Series III	B-72 – B-73
<a href="#">257-332</a>	Hermetic Jam Nut Receptacle w/ Crimp Removable Socket Contacts, Series III	B-74 – B-75
<a href="#">257-333</a>	Hermetic Jam Nut Receptacle w/ Crimp Removable Contacts, Series III	B-76 – B-77
<a href="#">947-082</a>	Jam Nut Hermetic Bulkhead Feed-Thru, Series III	B-78
<a href="#">947-115</a>	Jam Nut Hermetic Bulkhead Feed-Thru, Series III	B-79
<a href="#">947-282</a>	Flange Mount Hermetic Bulkhead Feed-Thru, Series III	B-80 – B-81
<a href="#">D38999/41 / 234-100-H2</a>	Box Mount Hermetic Receptacle, Series IV	B-82 – B-83
<a href="#">D38999/43 / 234-100-H7</a>	Jam Nut Mount Hermetic Receptacle, Series IV	B-84 – B-85
<a href="#">D38999/45 / 234-100-H5</a>	Solder Mount Hermetic Receptacle, Series IV	B-86 – B-87
<a href="#">D38999/48 / 234-100-H8</a>	Weld Mount Hermetic Receptacle, Series IV	B-88 – B-89
<a href="#">980-002</a>	Non-Environmental Rear Accessory Thread Adapter for MIL-DTL-38999/23 and /43	B-90 – B-91



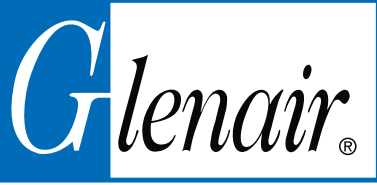

# MIL-DTL-38999 Series I, II, III, and IV Hermetic Class Connectors Insert Arrangements (IAW MIL-STD-1560)

**B**

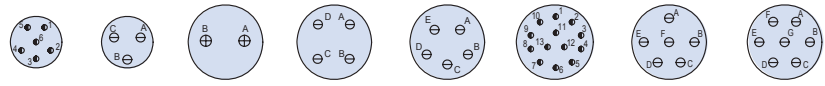

Series I	9-35	9-98	11-2	11-4	11-5	11-35	11-98	11-99
Series II	8-35	8-98	10-2		10-5	10-35	10-98	10-99
Series III	A35	A98	B2	B4	B5	B35	B98	B99
Series IV	---	---	B2	B4	B5	B35	B98	B99

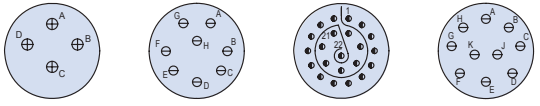

Series I	13-4	13-8	13-35	13-98
Series II	12-4	12-8	12-35	12-98
Series III	C4	C8	C35	C98
Series IV	C4	C8	C35	C98

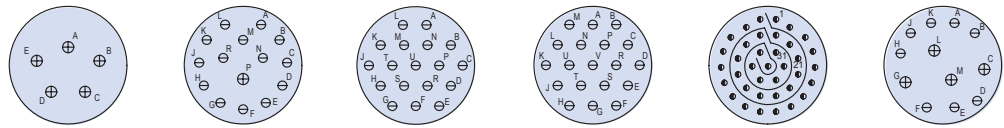

Series I	15-5	15-15	15-18	15-19	15-35	15-97
Series II	14-5	14-15	14-18	14-19	14-35	14-97
Series III	D5	D15	D18	D19	D35	D97
Series IV	D5	D15	D18	D19	D35	D97

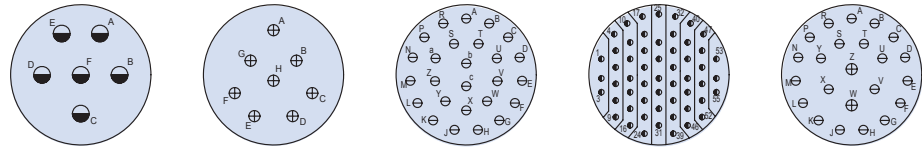

Series I	17-6	17-8	17-26	17-35	17-99
Series II	16-6	16-8	16-26	16-35	16-99
Series III	E6	E8	E26	E35	E99
Series IV	E6	E8	E26	E35	E99

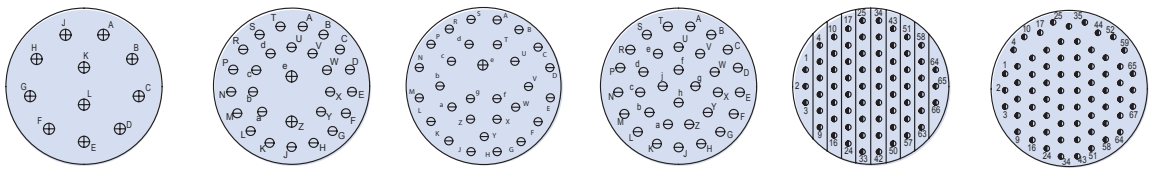

Series I	19-11	19-28	19-30	19-32	19-35	19-45
Series II	18-11	18-28	18-30	18-32	18-35	18-45
Series III	F11	F28	F30	F32	F35	F45
Series IV	F11	F28	F30	F32	F35	F45

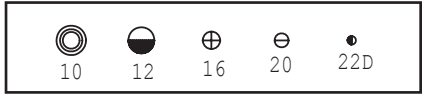

Dimensions in Inches (millimeters) are subject to change without notice.

# MIL-DTL-38999 Series I, II, III, and IV Hermetic Class Connectors Insert Arrangements (IAW MIL-STD-1560)



MIL-DTL-38999  
Hermetic Connectors

**B**

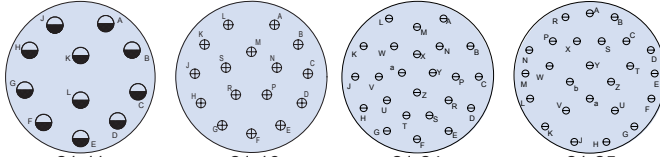

Series I	21-11	21-16	21-24	21-25
Series II	20-11	20-16	20-24	20-25
Series III, IV	G11	G16	G24	G25

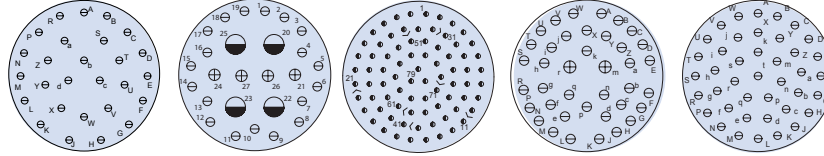

Series I	21-27	21-29	21-35	21-39	21-41
Series II	20-27	20-29	20-35	20-39	20-41
Series III, IV	G27	G29	H35	G39	G41

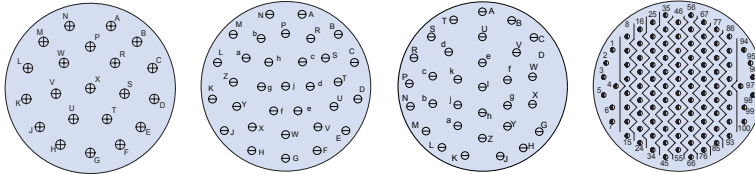

Series I	23-21	23-32	23-34	23-35
Series II	22-21	22-32	22-34	22-35
Series III, IV	H21	H32	H34	H35

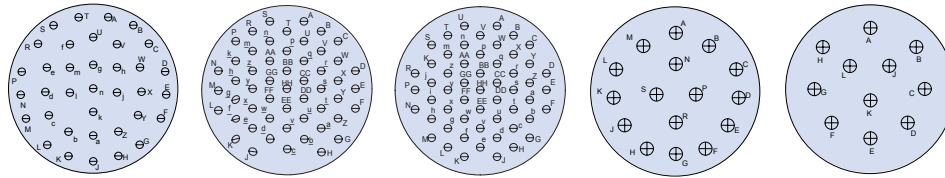

Series I	23-36	23-53	23-55	23-97	23-99
Series II	22-36	22-53	22-55	22-97	22-99
Series III, IV	H36	H53	H55	H97	H99

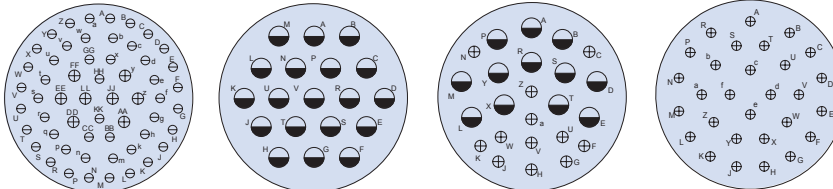

Series I	25-4	25-19	25-24	25-29
Series II	24-4	24-19	24-24	24-29
Series III, IV	J4	J19	J24	J29

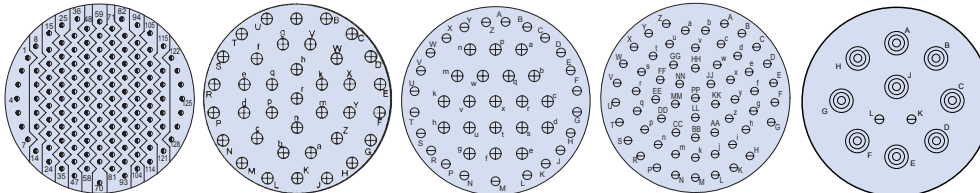

Series I	25-35	25-37	25-43	25-61	
Series II	24-35	25-37	24-43	24-61	(Series IV Only)
Series III, IV	J35	J37	J43	J61	J-11



Dimensions in Inches (millimeters) are subject to change without notice.

© 2013 Glenair, Inc.

U.S. CAGE Code 06324

Printed in U.S.A.

**GLENAIR, INC. • 1211 AIR WAY • GLENDALE, CA 91201-2497 • 818-247-6000 • FAX 818-500-9912**  
**www.glenair.com** **B-3** **E-Mail: sales@glenair.com**

Rev. 12.13.18

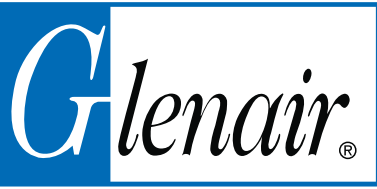

## MIL-DTL-38999 Series I, II, III, and IV Hermetic Class Connectors Layouts and Pin Counts

**B**

Shell Size and Insert Arrangements				Number of Pins			
MS Series I	MS Series II	D38999 Series III and IV	Service Rating	22D	20	16	12
9-35	8-35	A35	M	6			
9-98	8-98	A98	I		3		
11-2	10-2	B2	I			2	
11-4		B4	I		4		
11-5	10-5	B5	I		5		
11-35	10-35	B35	M	13			
11-98	10-98	B98	I		6		
11-99	10-99	B99	I		7		
13-4	12-4	C4	I			4	
13-8	12-8	C8	I		8		
13-35	12-35	C35	M	22			
13-98	12-98	C98	I		10		
15-5	14-5	D5	II			5	
15-15	14-15	D15	I		14	1	
15-18	14-18	D18	I		18		
15-19	14-19	D19	I		19		
15-35	14-35	D35	M	37			
15-97	14-97	D97	I		8	4	
17-6	16-6	E6	I				6
17-8	16-8	E8	II			8	
17-26	16-26	E26	I		26		
17-35	16-35	E35	M	55			
17-99	16-99	E99	I		21	2	
19-11	18-11	F11	II			11	
19-28	18-28	F28	I		26	2	
19-30	18-30	F30	I		29	1	
19-32	18-32	F32	I		32		
19-35	18-35	F35	M	66			

Shell Size and Insert Arrangements				Number of Pins			
MS Series I	MS Series II	D38999 Series III and IV	Service Rating	22D	20	16	12
19-45	18-45	F45	M	67			
21-11	20-11	G11	I				11
21-16	20-16	G16	II			16	
21-24	20-24	G24	I		24		
21-25	20-25	G25	I		25		
21-29		G29	I		19	4	4
21-27	20-27	G27	I		27		
21-35	20-35	G35	M	79			
21-39	20-39	G39	I		37	2	
21-41	20-41	G41	I		41		
23-21	22-21	H21	II			21	
23-32	22-32	H32	I		32		
23-34	22-34	H34	I		34		
23-35	22-35	H35	M	100			
23-36	22-36	H36	I		36		
23-53	22-53	H53	I		53		
23-55	22-55	H55	I		55		
23-97	22-97	H97	I			16	
23-99	22-99	H99	II			11	
25-4	24-4	J4	I		48	8	
25-19	24-19	J19	I				19
25-24	24-24	J24	I			12	12
25-29	24-29	J29	I			29	
25-35	24-35	J35	M	128			
25-37	N/A	J37				37	
25-43	24-43	J43	I		23	20	
25-61	24-61	J61	I		61		

Dimensions in Inches (millimeters) are subject to change without notice.

MIL-DTL-38999 Series I, II, III and IV  
Hermetic Class Connectors  
Material Specifications



TABLE I: HERMETIC CLASS MATERIALS

Shell, Barrel Coupling and Jam Nut (Hermetic)	Stainless steel per AMS-QQ-S-763
Shell, Barrel, Coupling Nut and Jam Nut (Hermetic)	Carbon steel per ASTM-A108, Tin plated per ASTM-B545
Front and Rear Insulators	Glass-filled liquid crystal polymer (LCP) in accordance with MIL-M-24519, Type GLP-30F
Grommet, Peripheral Seal and Interfacial Seal	Blended elastomer, 30% silicone per ZZ-R-765, 70% fluorosilicone per MIL-R-25988
Hermetic Insert	Vitreous glass
Pin Contact (Hermetic)	Nickel-iron alloy per ASTM F30 (Alloy 52), 50 microinches gold plated per ASTM B488 Type 3 Code C Class 1, 27 over nickel plate per QQ-N-290 Class 2, 50-100 microinches
Socket Contact (Hermetic)	Copper Alloy, Gold Plated IAW ASTM B488, Type 3, Code C
Adhesives	Silicone and epoxy
Potting Compound, PCB and Solder Cup Versions	Environmental and Hermetic Connectors: High-strength epoxy, Hysol EE4215. Filter Connectors: Stycast 2850FT/Catalyst 11 thermally conductive epoxy encapsulant.

TABLE II: HERMETIC CLASS FINISHES

Plating Code	Material	Finish	Specification
<b>Glenair Commercial Equivalent Plating Codes</b>			
Z1	Stainless Steel	Passivate	AMS-QQ-P-35
FT	Carbon Steel	Fused Tin Plate	ASTM-B545 or ASTM-B339
ZL	Stainless Steel	Electrodeposited Nickel	SAE-AMS-QQ-N-290, Class 2
<b>MIL-DTL-38999 Plating Codes</b>			
D	Carbon Steel	Fused Tin Plate	ASTM-B545 or ASTM-B339
Y	Stainless Steel	Passivate	AMS-QQ-P-35
N	Stainless Steel	Electrodeposited Nickel	SAE-AMS-QQ-N-290, Class 2

\*Additional materials are available, including titanium and Inconel®. Consult factory for ordering information.

Dimensions in Inches (millimeters) are subject to change without notice.





# MIL-DTL-38999 Connector Performance Specifications

**B**

Requirement	Performance Specifications					
Insert Arrangements	<i>(Meets MIL-DTL-38999, paragraph 3.4.1.4)</i> For hermetic connectors, the engaging end of pin and socket contacts shall be located within .004 inch (0.10 mm) diameter of true position. Test voltages for service ratings shall be as specified in table below					
	Test Voltages, ac rms, 60 Hz					
	Altitude	Service Rating M	Service Rating N	Service Rating I	Service Rating II	
	Sea level	1300	1000	1800	2300	
	50,000 feet	550	400	600	800	
	70,000 feet	350	260	400	500	
	100,000 feet	200	200	200	200	
Supported Wire Size	<i>(Per MIL-DTL-38999, paragraph 3.4.3.1)</i>					
	Contact Size	23-22	22D	20	16	12
Thermal Shock	Wire Gauge					
	26, 24, 22	28, 26, 24, 22	24, 22, 20	20, 18, 16	14, 12	10
Thermal Shock	<i>(Meets MIL-DTL-38999, paragraph 3.7)</i> After cycling the connector between two water baths of approximately 1 cubic foot, not to exceed +4°C for the first and no less than +90°C for the second, it will meet all applicable electrical and mechanical requirements.					
Air Leakage	<i>(Meets MIL-DTL-38999, paragraph 3.10)</i> There shall be no evidence of leakage in excess of .01 micron ft <sup>3</sup> /h (1E-7 cm <sup>3</sup> /s)					
Coupling and Uncoupling Torque	<i>(Meets MIL-DTL-38999, paragraph 3.11)</i> Coupling torque for mating and the uncoupling torque for unmating of counterpart plugs and receptacles, mating of connectors to and from protective covers, and mating plugs to and from dummy stowage receptacles, shall meet the requirements in <i>Coupling and Uncoupling Torque</i> table.					
	Coupling and Uncoupling Torque					
	Shell size	Maximum engagement and disengagement			Minimum disengagement	
		Pound inch			Pound inch	
	8	8			2	
	9	8			2	
	10	12			2	
	11	12			2	
	12	16			2	
	13	16			2	
	14	20			4	
	15	20			3	
	16	24			4	
	17	24			3	
	18	28			5	
19	28			3		
20	32			6		
21	32			5		
22	36			7		
23	36			5		
24	36			7		
25	40			5		
Durability	<i>(Meets MIL-DTL-38999, paragraph 3.12)</i> Not applicable to lanyard release plugs. No electrical or mechanical defects after 500 cycles of engagement and disengagement.					

Dimensions in Inches (millimeters) are subject to change without notice.

# MIL-DTL-38999 Connector Performance Specifications



Requirement	Performance Specifications																																		
Insulation Resistance	<p>(Meets MIL-DTL-38999, paragraph 3.14.1)  <b>At Ambient Temperature</b> insulation resistance between any pair of contacts and between any contact and the shell shall be greater than 5,000 megohms. Insulation resistance after altitude immersion shall be 1,000 megohms minimum. Insulation resistance after humidity shall be 100 megohms minimum. IAW EIA-364-21.            (Meets MIL-DTL-38999, paragraph 3.14.2)  <b>At Elevated Temperature</b> Unmated connectors shall be tested in accordance with test procedure EIA/ECA-364-21</p>																																		
Dielectric Withstanding Voltage	<p>(Meets MIL-DTL-38999, paragraph 3.15)            Wired, unmated connector, maximum leakage current shall be 2 milliamperes, and there shall be no evidence of electric breakdown or flashover. IAW EIA-364-20 method A. Magnitude of the test voltage shall be as specified per insert arrangement requirement, <i>Test Voltages Table</i> (See MIL-STD-1560 for service rating of insert arrangement).</p>																																		
Insert Retention	<p>(Meets MIL-DTL-38999, paragraph 3.16)            When tested IAW EIA-364-35, unmated connectors shall retain their inserts in their proper location in the shell and there shall be no evidence of cracking, breaking, separation from the shell, or loosening of parts when subjected to 100 PSI (25 PSI minimum) force</p>																																		
Salt Spray (Corrosion)	<p>(Meets MIL-DTL-38999, paragraph 3.17)            When tested in accordance with EIA-364-26, meets appropriate electrical and mechanical requirements and shows no exposure of base metal after 500 hours of salt spray.</p>																																		
Contact Resistance at 25° C	<p>(Meets MIL-DTL-38999, paragraph 3.18) <i>Hermetic connectors with sockets only</i>            Contacts in the mated condition shall meet the contact resistance requirements of the table shown below. Appropriate compensation may be made for resistance in the measured value which is due to an additional length of wire included in the measurement.</p>																																		
	<table border="1"> <thead> <tr> <th rowspan="2">Class</th> <th rowspan="2">Contact Size</th> <th rowspan="2">Wire Size</th> <th rowspan="2">Test Amperes</th> <th colspan="2">Millivolt Drop Maximum</th> </tr> <tr> <th>Initial</th> <th>After Conditioning</th> </tr> </thead> <tbody> <tr> <td rowspan="5">H, N and Y</td> <td>12</td> <td>12</td> <td>17</td> <td>85</td> <td>100</td> </tr> <tr> <td>16</td> <td>16</td> <td>10</td> <td>85</td> <td>100</td> </tr> <tr> <td>20</td> <td>20</td> <td>5</td> <td>60</td> <td>75</td> </tr> <tr> <td>22D</td> <td>22</td> <td>3</td> <td>85</td> <td>95</td> </tr> <tr> <td>23-22</td> <td>22</td> <td>3</td> <td>85</td> <td>95</td> </tr> </tbody> </table>	Class	Contact Size	Wire Size	Test Amperes	Millivolt Drop Maximum		Initial	After Conditioning	H, N and Y	12	12	17	85	100	16	16	10	85	100	20	20	5	60	75	22D	22	3	85	95	23-22	22	3	85	95
	Class					Contact Size	Wire Size	Test Amperes	Millivolt Drop Maximum																										
		Initial	After Conditioning																																
	H, N and Y	12	12	17	85	100																													
		16	16	10	85	100																													
20		20	5	60	75																														
22D		22	3	85	95																														
23-22		22	3	85	95																														
Bayonet Coupling Pin Strength	<p>(Meets MIL-DTL-38999, paragraph 3.21)            Applicable to series I and II only. Bayonet coupling pins shall withstand a load of 50 +5/-0 pounds without displacement or perceptible loosening of coupling pins.</p>																																		
Environmental Contact Retention Connectors	<p>(Meets MIL-DTL-38999, paragraph 3.24)            The axial displacement of the contact shall not exceed .012 inch (0.30 mm).            No damage to contacts or inserts shall result.</p>																																		
Vibration	<p>(Meets MIL-DTL-38999, paragraph 3.27)            There shall be no electrical discontinuity and there shall be no disengagement of mated connectors, backing off of the coupling mechanism, evidence of cracking, breaking, or loosening of parts.</p>																																		

Dimensions in Inches (millimeters) are subject to change without notice.



# MIL-DTL-38999 Connector Performance Specifications

**B**

Requirement	Performance Specifications																																																																					
Shock	<p><i>(Meets MIL-DTL-38999, paragraph 3.28)</i> There shall be no electrical discontinuity and there shall be no disengagement of mated connectors, evidence of cracking, breaking, or loosening of parts. <b>Standard shock</b> (all series). Connectors shall be tested in accordance with test procedure EIA-364-27 and any additional details noted. <b>High-impact shock.</b> Applicable to series I, III and IV only. Wired and mated connectors shall be tested in accordance with MIL-S-901, grade A and in accordance with any modifications or additions noted. The wire bundle shall be provided with a straight, environmental, backshell, category 2B in accordance with SAE-AS85049, the longest length available per shell size. Discontinuity monitoring shall be performed in accordance with EIA-364-46.</p>																																																																					
EMI Shielding	<p><i>(Meets MIL-DTL-38999, paragraph 3.32)</i> <b>EMI shielding, low frequencies</b> Applicable frequency range is 100 to 1,000 MHz only. <b>EMI shielding, high frequencies.</b> Applicable frequency range is 1,000 to 10,000 MHz only. The EMI shielding effectiveness of mated connectors with EMI backshells shall be measured using the mode-stirred technique in accordance with test procedure EIA-364-66. EMI shielding capabilities of mated shells with spring fingers shall not be less than that specified in table at the specified frequencies below.</p> <table border="1"> <thead> <tr> <th rowspan="2">Frequency MHz</th> <th colspan="4">Leakage Attenuation (dB) Minimum</th> </tr> <tr> <th>Series I</th> <th>Series II</th> <th>Series III &amp; IV (Class N)</th> <th>Series III &amp; IV (Class H &amp; Y)</th> </tr> </thead> <tbody> <tr><td>100</td><td>90</td><td>65</td><td>90</td><td>80</td></tr> <tr><td>200</td><td>88</td><td>60</td><td>88</td><td>75</td></tr> <tr><td>300</td><td>88</td><td>55</td><td>88</td><td>73</td></tr> <tr><td>400</td><td>87</td><td>55</td><td>87</td><td>71</td></tr> <tr><td>800</td><td>85</td><td>45</td><td>85</td><td>66</td></tr> <tr><td>1,000</td><td>85</td><td>45</td><td>85</td><td>65</td></tr> <tr><td>1,500</td><td>69</td><td>—</td><td>76</td><td>59</td></tr> <tr><td>2,000</td><td>65</td><td>—</td><td>70</td><td>55</td></tr> <tr><td>3,000</td><td>61</td><td>—</td><td>69</td><td>52</td></tr> <tr><td>4,000</td><td>58</td><td>—</td><td>68</td><td>50</td></tr> <tr><td>6,000</td><td>55</td><td>—</td><td>66</td><td>48</td></tr> <tr><td>10,000</td><td>50</td><td>—</td><td>65</td><td>45</td></tr> </tbody> </table>	Frequency MHz	Leakage Attenuation (dB) Minimum				Series I	Series II	Series III & IV (Class N)	Series III & IV (Class H & Y)	100	90	65	90	80	200	88	60	88	75	300	88	55	88	73	400	87	55	87	71	800	85	45	85	66	1,000	85	45	85	65	1,500	69	—	76	59	2,000	65	—	70	55	3,000	61	—	69	52	4,000	58	—	68	50	6,000	55	—	66	48	10,000	50	—	65	45
Frequency MHz	Leakage Attenuation (dB) Minimum																																																																					
	Series I	Series II	Series III & IV (Class N)	Series III & IV (Class H & Y)																																																																		
100	90	65	90	80																																																																		
200	88	60	88	75																																																																		
300	88	55	88	73																																																																		
400	87	55	87	71																																																																		
800	85	45	85	66																																																																		
1,000	85	45	85	65																																																																		
1,500	69	—	76	59																																																																		
2,000	65	—	70	55																																																																		
3,000	61	—	69	52																																																																		
4,000	58	—	68	50																																																																		
6,000	55	—	66	48																																																																		
10,000	50	—	65	45																																																																		
Fluid Immersion	<p><i>(Meets MIL-DTL-38999, paragraph 3.34)</i> Designed to function in all fluids encountered in any modern military or aerospace environment. Tested in accordance with test procedure EIA-364-10. Connectors shall be tested for coupling torque and dielectric withstanding voltage at sea level within 3 hours of fluid immersion cycles.</p>																																																																					
Contact engagement and separating force	<p><i>(Meets MIL-DTL-38999, paragraph 3.42)</i> <b>Applicable to hermetic connectors with sockets only</b> When tested as specified in 4.5.38, contact engagement and separating forces shall be within the limits specified in SAE-AS39029.</p>																																																																					
Resistance to Probe Damage	<p><i>(Meets MIL-DTL-38999, paragraph 3.43)</i> <b>Applicable to hermetic connectors with sockets only</b> Contacts shall withstand the bending moment and depth of test probe insertion without evidence of damage that would interfere with the mechanical or electrical performance.</p>																																																																					
Fungus	<p><i>(Meets MIL-DTL-38999, paragraph 4.2.2)</i> Materials used in the construction of these connectors shall be fungus inert per certification of method 508.4 of MIL-STD-810.</p>																																																																					

Dimensions in Inches (millimeters) are subject to change without notice.

# MIL-DTL-38999 Contact Materials and Performance Specifications



MIL-DTL-38999 Contact Materials		
Component	Material	Notes
Pin Contact	Beryllium copper alloy per ASTM B197, 50 microinches gold plated per ASTM B488 Type 3 Code C Class 1,27 over nickel plate per QQ-N-290 Class 2, 50-100 microinches.	Approved for Space Flight
Pin Contact, Hermetic	Nickel-iron alloy per ASTM F30 (Alloy 52),50 microinches gold plated per ASTM B488 Type 3 Code C Class 1,27 over nickel plate per QQ-N-290 Class 2, 50-100 microinches.	Ferromagnetic material.
Socket Contact	Beryllium copper alloy per ASTM B197, 50 microinches gold plated per ASTM B488 Type 3 Code C Class 1,27 over nickel plate per QQ-N-290 Class 2, 50-100 microinches.	Approved for Space Flight
Socket Contact Hood	Stainless steel, passivated per AMS-QQ-P-35.	Approved for Space Flight

Requirement	Contact Performance Specifications		
Current Rating (Per SAE-AS39029, Paragraph 3.5.4)	Contact Size	Maximum Amps	
		Crimp	Hermetic
	23-22	5	3
	22D	5	3
	20	7.5	5
	16	13	10
	10	33	24
Contact Resistance, Type A (Per SAE-AS39029, Paragraph 3.5.4.1) The contact voltage drop of each mated copper alloy contact pair shall not exceed the applicable values specified.	Wire Size	Test Current Amperes	Maximum Voltage Drop (Millivolts) at 25°C ±3°C
	10	33	33
	12	23	42
	16	13	49
	20	7.5	55
	22	22	73
Contact Resistance, Type B (Per SAE-AS39029, Paragraph 3.5.4.2) The contact voltage drop of each ferrous alloy contact with its applicable mating copper alloy contact shall not exceed the applicable values specified.	Wire Size	Test Current Amperes	Maximum Voltage Drop (Millivolts) at 25°C ±3°C
	10	23	363
	12	17	462
	16	10	539
	20	55	605
	22	3	803

Dimensions in Inches (millimeters) are subject to change without notice.





MIL-DTL-38999 Series I and II  
Alternate Keyway Positions

B

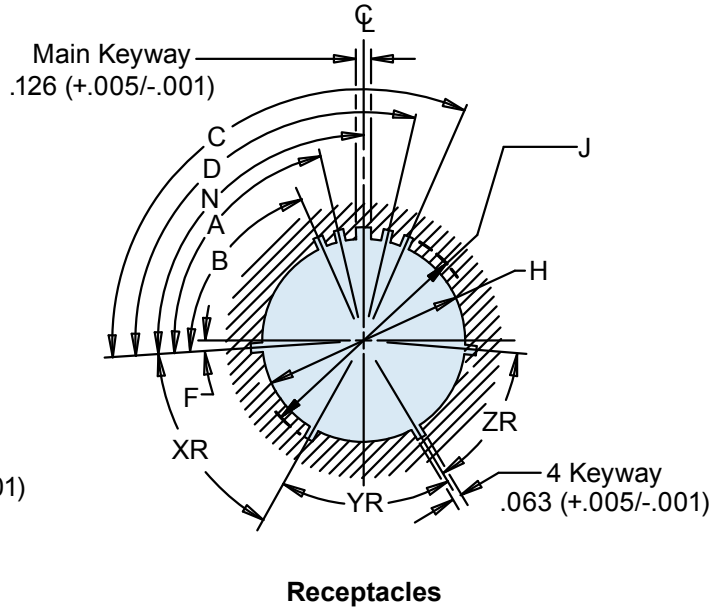
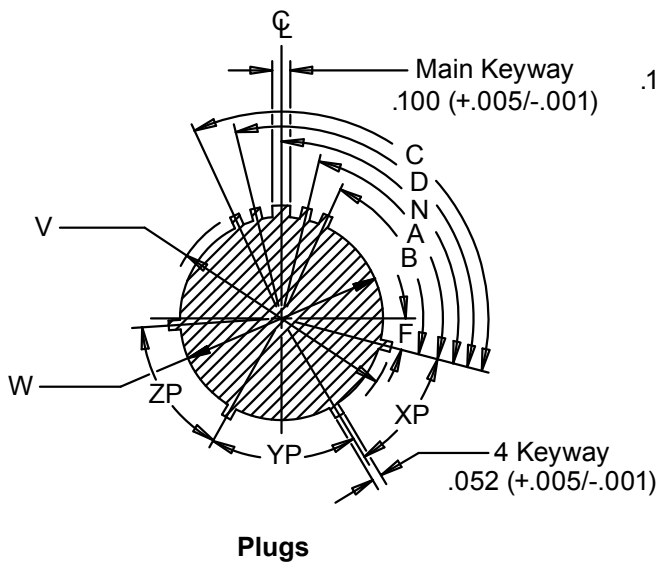

SERIES I ALTERNATE KEY POLARIZATION									
Shell Size	F	Normal Rotation				Letter Designation			
		N	XR XP	YR YP	ZR ZP	A	B	C	D
9	5°	95°	45°	88°	27°	77°	---	---	113°
11	5°	95°	45°	88°	27°	81°	67°	123°	109°
13	5°	95°	45°	88°	27°	75°	63°	127°	115°
15	5°	95°	45°	88°	27°	74°	61°	129°	116°
17	5°	95°	45°	88°	27°	77°	65°	125°	113°
19	5°	95°	45°	88°	27°	77°	65°	125°	113°
21	5°	95°	45°	88°	27°	77°	65°	125°	113°
23	5°	95°	45°	88°	27°	80°	69°	121°	110°
25	5°	95°	45°	88°	27°	80°	69°	121°	110°

SERIES II ALTERNATE KEY POLARIZATION									
Shell Size	F	Normal Rotation				Letter Designation			
		N	XR XP	YR YP	ZR ZP	A	B	C	D
8	10°	100°	28°	100°	37°	82°	---	---	118°
10	10°	100°	28°	100°	37°	86°	72°	128°	114°
12	10°	100°	28°	100°	37°	80°	68°	132°	120°
14	10°	100°	28°	100°	37°	79°	66°	134°	121°
16	10°	100°	28°	100°	37°	82°	70°	130°	118°
18	10°	100°	28°	100°	37°	82°	70°	130°	118°
20	10°	100°	28°	100°	37°	82°	70°	130°	118°
22	10°	100°	28°	100°	37°	85°	74°	126°	115°
24	10°	100°	28°	100°	37°	85°	74°	126°	115°

Dimensions in Inches (millimeters) are subject to change without notice.

# MIL-DTL-38999 Series III Alternate Keyway Positions



**B**

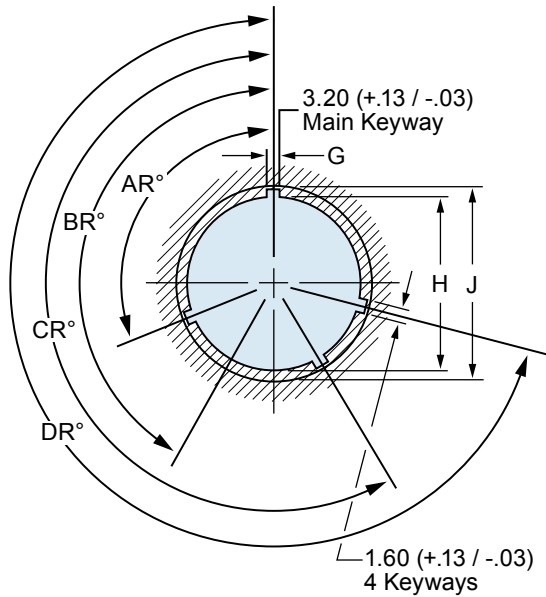

**Receptacles**

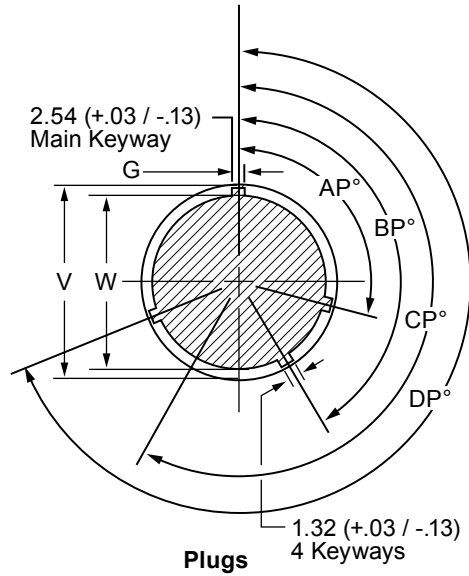

**Plugs**

SERIES III ALTERNATE KEY POLARIZATION					
Shell Size	Key and Keyway Arrangement Identification Letter	AR° or AP° BSC	BR° or BP° BSC	CR° or CP° BSC	DR° or DP° BSC
9	N	105	140	215	265
	A	102	132	248	320
	B	80	118	230	312
	C	35	140	205	275
	D	64	155	234	304
11 13 and 15	E	91	131	197	240
	N	95	141	208	236
	A	113	156	182	292
	B	90	145	195	252
	C	53	156	220	255
17 and 19	D	119	146	176	298
	E	51	141	184	242
	N	80	142	196	293
	A	135	170	200	310
	B	49	169	200	244
21 23 and 25	C	66	140	200	257
	D	62	145	180	280
	E	79	153	197	272
	N	80	142	196	293
	A	135	170	200	310
21 23 and 25	B	49	169	200	244
	C	66	140	200	257
	D	62	145	180	280
	E	79	153	197	272

Dimensions in Inches (millimeters) are subject to change without notice.



MIL-DTL-38999 Series IV  
Alternate Keyway Positions

B

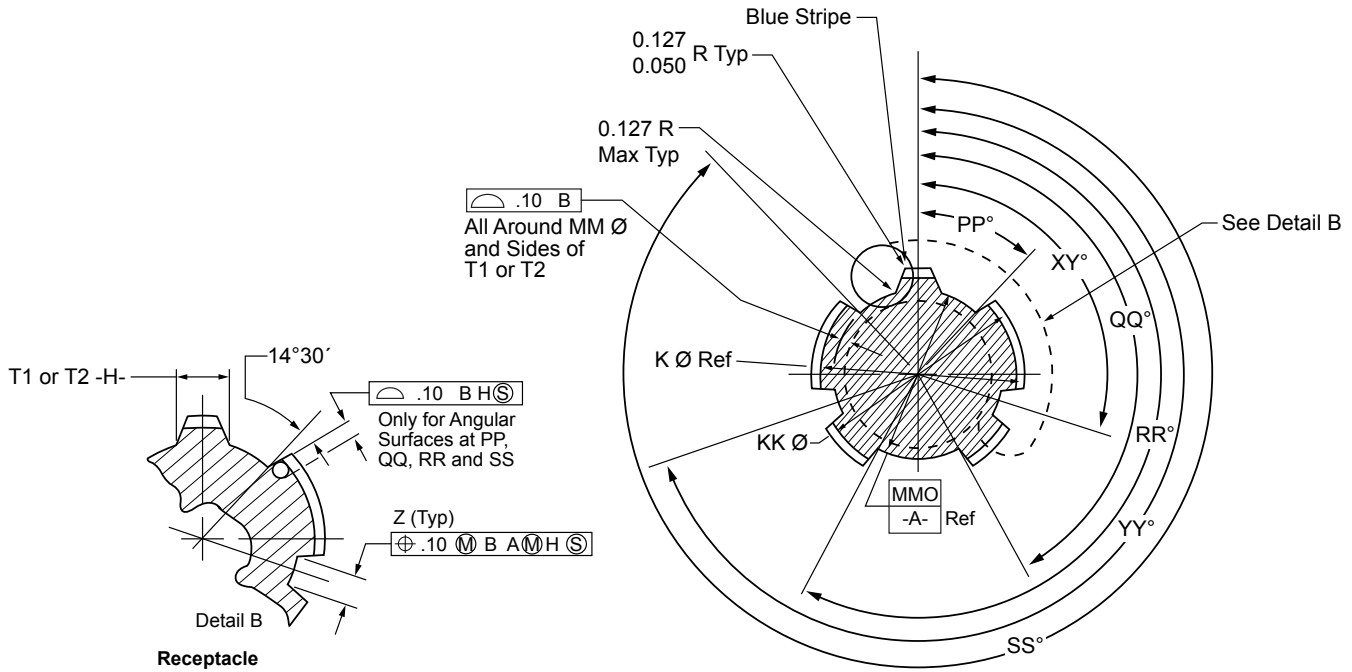

SERIES IV ALTERNATE KEY POLARIZATION										
Shell Size Code	Receptacle Main Key and Keyway Polarization								Main Key BSC	
	Shell Size	MM Dia BSC	PP°	QQ°	RR°	SS°	Z	Z <sup>2</sup>	Socket Contact T1	Pin Contact T2
B	11	13.09	44°28'	151°6'	208°54'	315°32'	1.83	2.46	1.90	2.78
C	13	16.51	44°25'	150°31'	209°29'	315°35'	1.52	2.16	1.94	2.85
D	15	19.69	44°33'	150°24'	209°36'	315°27'	2.34	3.23	2.43	3.36
E	17	22.89	44°36'	150°22'	209°38'	315°24'	2.03	2.92	2.45	3.40
F	19	25.79	44°33'	150°27'	209°33'	315°27'	2.85	3.99	2.96	3.91
G	21	28.96	44°34'	150°23'	209°37'	315°26'	2.54	3.68	2.99	3.94
H	23	32.14	44°34'	150°20'	209°40'	315°26'	3.35	4.75	3.50	4.46
J	25	35.31	44°42'	150°22'	209°388'	315°18'	3.04	4.45	3.53	4.49

Dimensions are in Millimeters

SERIES IV ALTERNATE KEY POLARIZATION										
	N	A	B	C	D	K	L	M	R	U
X° XX°	110°	100°	90°	80°	70°	120°	120°	120°	120°	0°
Y° YY°	250°	260°	270°	280°	290°	255°	265°	275°	285°	0°

Dimensions in Inches (millimeters) are subject to change without notice.

# Recommended Torque Values



## INSTALLATION TORQUE VALUES FOR CIRCULAR ELECTRICAL CONNECTOR ACCESSORIES

Shell Sizes	Column 1 Light and Medium Duty AS50151 (AS31001 Series) MIL-DTL-26482 Series I MIL-DTL-26500, MIL-DTL-27599 MIL-DTL-38999 Series I and II MIL-C-81511 Series I, II, III and IV AS81703 Series I	Column 2 Heavy Duty AS50151 (AS34001 Series) MIL-DTL-22992, MIL-DTL-28840 MIL-DTL-26482 Series II MIL-DTL-38999 Series III and IV MIL-DTL-83723 Series I, II and III, AS81703 Series III	Column 3 Composite Material Coupling Threads (See Notes 1 and 2)
	In-Lbs, Min/Max	In-Lbs, Min/Max	In-Lbs, Min/Max
8, 9, A	30/40	51/61	20/25
3, 10, 10SL, 11, B	30/40	71/81	20/30
7, 12, 12S, 13, C	35/45	103/113	25/35
14, 14S, 15, D	35/45	111/121	25/35
16, 16S, 17, E	35/45	111/121	30/40
18, 19, 27, F	35/45	111/121	30/40
20, 21, 37, G	75/85	131/141	35/45
22, 23, H	75/85	131/141	35/45
24, 25, 61, J	75/85	131/141	35/45
28, 29	115/125	143/153	115/125
32, 33	115/125	143/153	115/125
36	115/125	142/153	112/125
40	155/165	159/169	N/A
44	155/165	159/169	N/A
48	155/165	159/169	N/A

### RECOMMENDED JAM NUT TORQUE VALUES

Series II		Series I, III, IV	
Shell Size	In-Lbs Min/Max	Shell Size	In-Lbs Min/Max
8	46/50	9	30/36
10	55/60	11	40/46
12	70/75	13	55/60
14	80/85	15	70/75
16	90/95	17	80/85
18	100/110	19	90/95
20	110/120	21	100/110
22	120/130	23	110/120
24	140/150	25	120/130

### TORQUE VALUES FOR CABLE CLAMP SCREWS <sup>5, 6</sup>

Screw Size	In-Lbs Min/Max
2-56	1.5/2.5
4-40	3.5/4.5
6-32	5.0/7.0
8-32	7.0/9.0
10-32	9.0/11.0
.250-20	11.0/13.0

### CABLE CLAMP TORQUE VALUES

Clamp Size	With Grommet <sup>4</sup>	Without Grommet
	In-Lbs Min/Max	In-Lbs Min/Max
3	8/12	30/40
4	10/15	30/40
6	10/15	35/55
8	12/20	35/55
10	12/20	35/55
12	15/30	40/60
16	20/40	40/60
20	20/40	40/60
24	25/45	80/100
28	30/50	80/100
32	30/50	80/100
40	40/60	80/100

- 1) Use Glenair 600-091/157 and 600-007 torque tools when tightening hexagonal composite accessory couplings.
- 2) Metal and composite torque values per SAE AIR 6151. All values provided in Inch-Pounds.
- 3) For additional guidance or values/conditions not listed, refer to SAE AIR6151.
- 4) Values are based on lubricated grommets and clamp threads.
- 5) For stainless-steel or plated steel screws into aluminum or stainless-steel.
- 6) Not applicable for light-duty saddles unless bottomed on clamp nut.

EMI/RFI shielding terminated with conical metal ferrule(s) should employ a minimum recommended torque of 35 in-lb.

Dimensions in Inches (millimeters) are subject to change without notice.





## MIL-DTL-38999 Hermetic Connectors and Environmental Mates

B

Hermetic	Environmental	Hermetic	Environmental
230-003P09-35PN	D38999/26FA35SN	D38999/21YA98PN	D38999/26FA98SN
230-003P09-35PN	D38999/26FA35SN	D38999/21YB35XA	D38999/26FB35SA
230-003P15-97DN	D38999/26FD97PN	D38999/21YB5PN	D38999/26FB5SN
230-003P19-11DN	D38999/26FF11PN	D38999/21YB5PN	D38999/26FB5SN
231-100-H7Z113-35PN	MS27467E13F35S	D38999/21YB98PB	D38999/26FB98SB
231-100-H7Z113-35PN	MS27467E13F35S	D38999/21YB98PC	D38999/26FB98SC
231-100-H7Z113-35PN	MS27467E13F35S	D38999/21YB98PN	D38999/26FB98SN
231-100-H7Z113-35PN	MS27467E13F35S	D38999/21YB99PN	D38999/26FB99SN
231-100-H7Z113-35PN	MS27467E13F35S	D38999/21YC35PN	D38999/26FC35SN
231-100-H7Z113-35PN	MS27467E13F35S	D38999/21YC4PN	D38999/26FC4SN
231-100-H7Z113-35PN	MS27467E13F35S	D38999/21YC4PN	D38999/26FC4SN
231-100-H7Z115-35PA	MS27467E15F35SA	D38999/21YC4PN	D38999/26FC4SN
231-100-H7Z115-35PA	MS27467E15F35SA	D38999/21YC4SN	D38999/26FC4PN
231-100-H7Z115-35PA	MS27467E15F35SA	D38999/21YC4SN	D38999/26FC4PN
231-100-H7Z115-35PA	MS27467E15F35SA	D38999/21YC4SN	D38999/26FC4PN
231-100-H7Z115-35PA	MS27467E15F35SA	D38999/21YC98PA	D38999/26FC98SA
231-100-H7Z115-35PA	MS27467E15F35SA	D38999/21YC98PA	D38999/26FC98SA
231-100-H7Z115-35PA	MS27467E15F35SA	D38999/21YC98PA	D38999/26FC98SA
231-100-H7Z115-35PA	MS27467E15F35SA	D38999/21YC98PA	D38999/26FC98SA
231-100-H7Z117-35PN	MS27467E17F35S	D38999/21YD5PN	D38999/26FD5SN
231-100-H7Z117-35PN	MS27467E17F35S	D38999/21YD97PA	D38999/26FD97SA
231-100-H7Z117-35PN	MS27467E17F35S	D38999/21YD97PA	D38999/26FD97SA
231-100-H7Z117-35PN	MS27467E17F35S	D38999/21YD97PN	D38999/26FD97SN
231-100-H7Z117-35PN	MS27467E17F35S	D38999/21YE6XN	D38999/26FE6SN
231-100-H7Z117-35PN	MS27467E17F35S	D38999/21YG16PN	D38999/26FG16SN
231-100-H7ZL17-35PN	MS27467E17F35S	D38999/21YG39PN	D38999/26FG39SN
232-100-H5Z110-35PN	MS27473E10F35S	D38999/23NA35PN	D38999/26FA35SN
233-100-H7ZL17-06DN	D38999/26FE6PN	D38999/23NB5SN	D38999/26FB5PN
233-100-H7ZL17-06DN	D38999/26FE6PN	D38999/23ND35PA	D38999/26FD35SA
D38999/21NA35PN	D38999/26FA35SN	D38999/23ND97DN	D38999/26FD97PN
D38999/21NA35PN	D38999/26FA35SN	D38999/23NF11DN	D38999/26FF11PN
D38999/21NB35PN	D38999/26FB35SN	D38999/23NG16PN	D38999/26FG16SN
D38999/21ND35PA	D38999/26FD35SA	D38999/23NG16PN	D38999/26FG16SN
D38999/21NJ19PN	D38999/26FJ19SN	D38999/23YA35PN	D38999/26FA35SN
D38999/21NJ19PN	D38999/26FJ19SN	D38999/23YA35PN	D38999/26FA35SN
D38999/21NJ35DA	D38999/26FJ35PA	D38999/23YA35PN	D38999/26FA35SN
D38999/21NJ35DA	D38999/26FJ35PA	D38999/23YB35CN	D38999/26FB35SN
D38999/21NJ35DB	D38999/26FJ35PB	D38999/23YB35PA	D38999/26FB35SA
D38999/21NJ35DB	D38999/26FJ35PB	D38999/23YB35PN	D38999/26FB35SN
D38999/21NJ35DC	D38999/26FJ35DC	D38999/23YB35PN	D38999/26FB35SN
D38999/21NJ35DC	D38999/26FJ35DC	D38999/23YB35PN	D38999/26FB35SN
D38999/21YA98PN	D38999/26FA98SN	D38999/23YB35SN	D38999/26FB35PN

Dimensions in Inches (millimeters) are subject to change without notice.

## MIL-DTL-38999 Hermetic Connectors and Environmental Mates



Hermetic	Environmental
D38999/23YB35SN	D38999/26FB35PN
D38999/23YB35SN	D38999/26FB35PN
D38999/23YB98PN	D38999/26FB98SN
D38999/23YC35PC	D38999/26FC35SC
D38999/23YC35PN	D38999/26FC35SN
D38999/23YC35SB	D38999/26FC35PB
D38999/23YC35SB	D38999/26FC35PB
D38999/23YC35SB	D38999/26FC35PB
D38999/23YC35SN	D38999/26FC35PN
D38999/23YC35SN	D38999/26FC35PN
D38999/23YC4PN	D38999/26FC4SN
D38999/23YC98PN	D38999/26FC98SN
D38999/23YC98PN	D38999/26FC98SN
D38999/23YC98PN	D38999/26FC98SN
D38999/23YC98PN	D38999/26FC98SN
D38999/23YE26SA	D38999/26FE26PA
D38999/23YE6SN	D38999/26FE6PN
D38999/23YG41CN	D38999/26FG41SN
D38999/23YH35CN	D38999/26FH35SN
D38999/23YH35PA	D38999/26FH35SA
D38999/23YH35PA	D38999/26FH35SA
D38999/23YJ29SN	D38999/26FJ29PN
D38999/23YJ29SN	D38999/26FJ29PN
D38999/25YH35PN	D38999/26FH35SN
D38999/48YC35PN	D38999/46FC35SN
MS27469Y23N35C	MS27467E23F35S
MS27470Y11D35S	MS27467E11F35P
MS27470Y15E35PA	MS27467E15F35SA
MS27470Y23D21P	MS27467E23F21S
MS27471Y11E35P	MS27467E11F35S
MS27471Y11E35P	MS27467E11F35S
MS27471Y13D98PB	MS27467E13F98SB
MS27475Y10E35P	MS27473E10F35S
MS27477Y14E18PB	MS27473E14F18SB
MS27477Y14N18S	MS27473E14F18P
MS27478Y10E35P	MS27473E10F35S
MS27478Y10N35C	MS27473E10F35S
MS27478Y10N35C	MS27473E10F35S
MS27478Y18N35P	MS27473E18F35S

Dimensions in Inches (millimeters) are subject to change without notice.

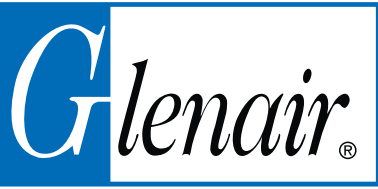

# MS27469

## Wall Mount Hermetic Receptacle MIL-DTL-38999 Series I

### How To Order: MS

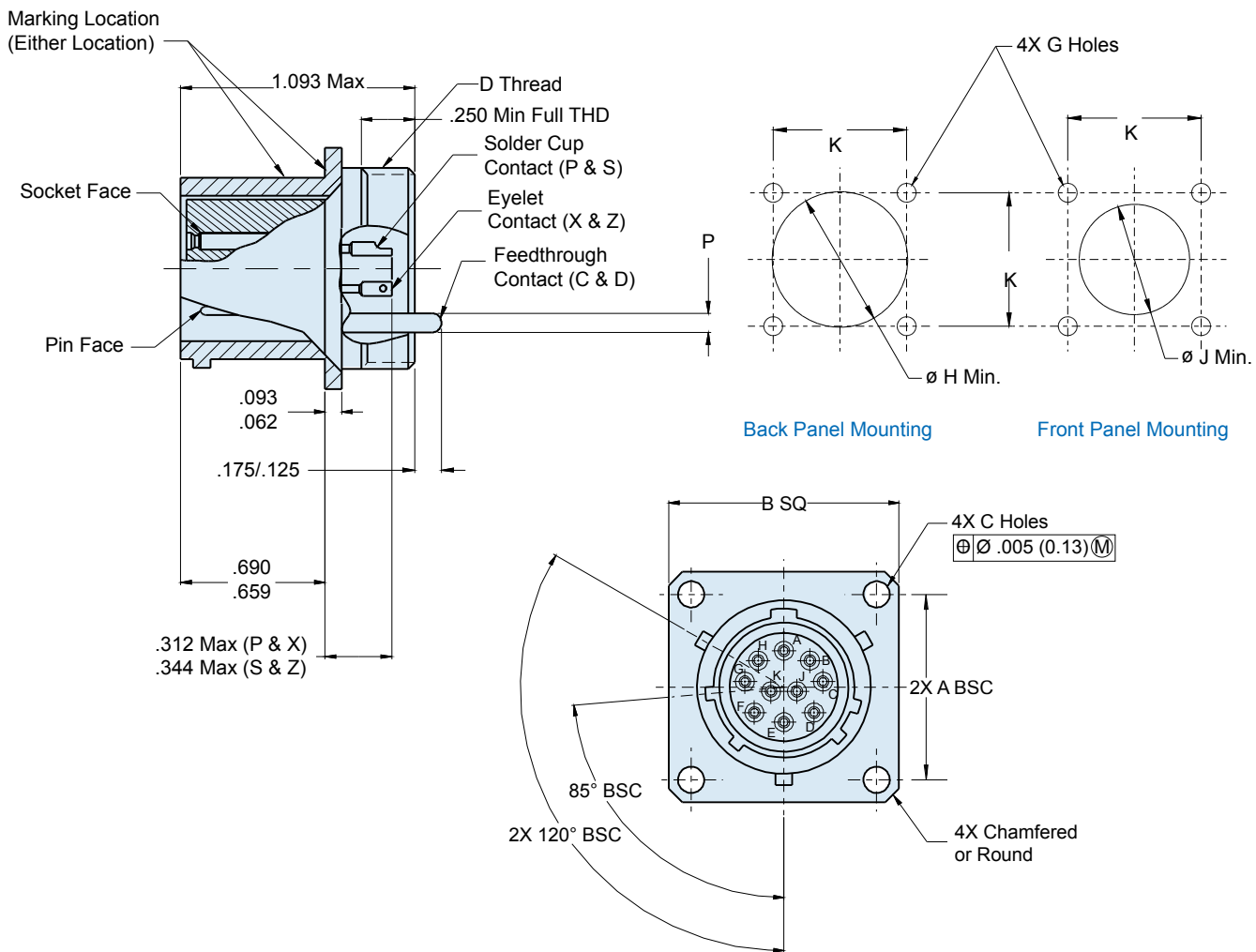
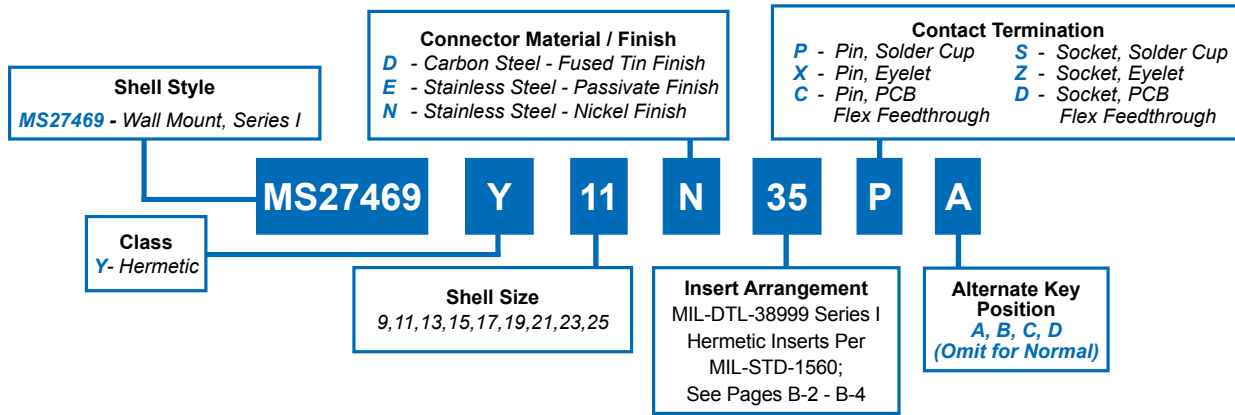

Dimensions in Inches (millimeters) are subject to change without notice.

# 231-100-H0

## Wall Mount Hermetic Receptacle

### MIL-DTL-38999 Series I Type



### How To Order: Commercial

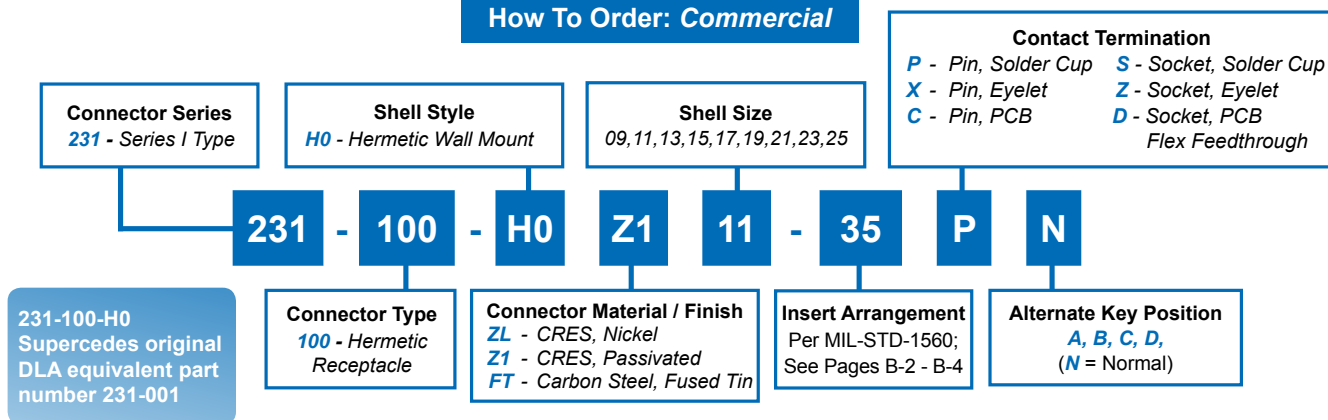

TABLE I: CONNECTOR DIMENSIONS

SHELL SIZE	A BSC	B SQ ±.016(0.4)	ø C HOLES .123(3.1)	D THREADS
9/09	.719(18.3)	.938(23.8)	.133(3.4) .123(3.1)	.6875-24 UNEF-2A
11	.812(20.6)	1.031(26.2)	.133(3.4) .123(3.1)	.8125-20 UNEF-2A
13	.906(23.0)	1.125(28.6)	.133(3.4) .123(3.1)	.9375-20 UNEF-2A
15	.969(24.6)	1.219(31.0)	.133(3.4) .123(3.1)	1.0625-18 UNEF-2A
17	1.062(27.0)	1.312(33.3)	.133(3.4) .123(3.1)	1.1875-18 UNEF-2A
19	1.156(29.4)	1.438(36.5)	.133(3.4) .123(3.1)	1.3125-18 UNEF-2A
21	1.250(31.8)	1.562(39.7)	.133(3.4) .123(3.1)	1.4375-10 UNEF-2A
23	1.375(34.9)	1.688(42.9)	.157(4.0) .142(3.6)	1.5625-18 UNEF-2A
25	1.500(38.1)	1.812(46.0)	.157(4.0) .142(3.6)	1.6875-18 UNEF-2A

HERMETIC LEAK RATE MOD CODES

Designator	Required Leak Rate
-585A	1 x 10 <sup>-10</sup> cc Helium per second
-585B	1 x 10 <sup>-9</sup> cc Helium per second
-585C	1 x 10 <sup>-8</sup> cc Helium per second

TABLE II: CONTACT SIZE

PRINTED CIRCUIT TAIL CONFIGURATIONS CONTACT STYLE C AND D

Contact Size	ø P
22D	.011 (0.28) .015 (0.38)
20	.024 (0.61) .028 (0.71)
16	.0635 (1.61) .0615 (1.56)
12	.095 (2.41) .093 (2.36)

TABLE I (CONTINUED): CONNECTOR DIMENSIONS

SHELL SIZE	ø G HOLES ±.005(0.1)	ø H MIN	ø J MIN	K ±.005(0.1)
9/09	.128(3.3)	.656(16.7)	.697(17.7)	.719(18.3)
11	.128(3.3)	.796(20.2)	.822(20.9)	.812(20.6)
13	.128(3.3)	.921(23.4)	.947(24.1)	.906(23.0)
15	.128(3.3)	1.047(26.6)	1.072(27.2)	.968(24.6)
17	.128(3.3)	1.218(30.9)	1.197(30.4)	1.062(27.0)
19	.128(3.3)	1.296(32.9)	1.322(33.6)	1.156(29.4)
21	.128(3.3)	1.421(36.1)	1.447(36.8)	1.250(31.8)
23	.154(3.9)	1.546(39.3)	1.572(39.9)	1.375(34.9)
25	.154(3.9)	1.672(42.5)	1.697(43.1)	1.500(38.1)

WIRE ACCOMODATION

Contact Size	Wire Guage
22D	#22 - #28
20	#20 - #24
16	#16 - #20
12	#12 - #14

Dimensions in Inches (millimeters) are subject to change without notice.





# MS27470 Jam Nut Mount Hermetic Receptacle MIL-DTL-38999 Series I

## How To Order: MS

**B**

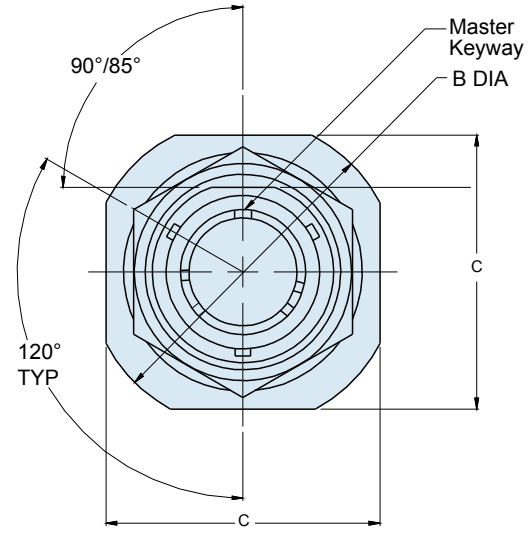
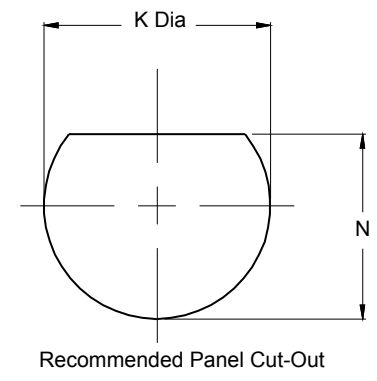
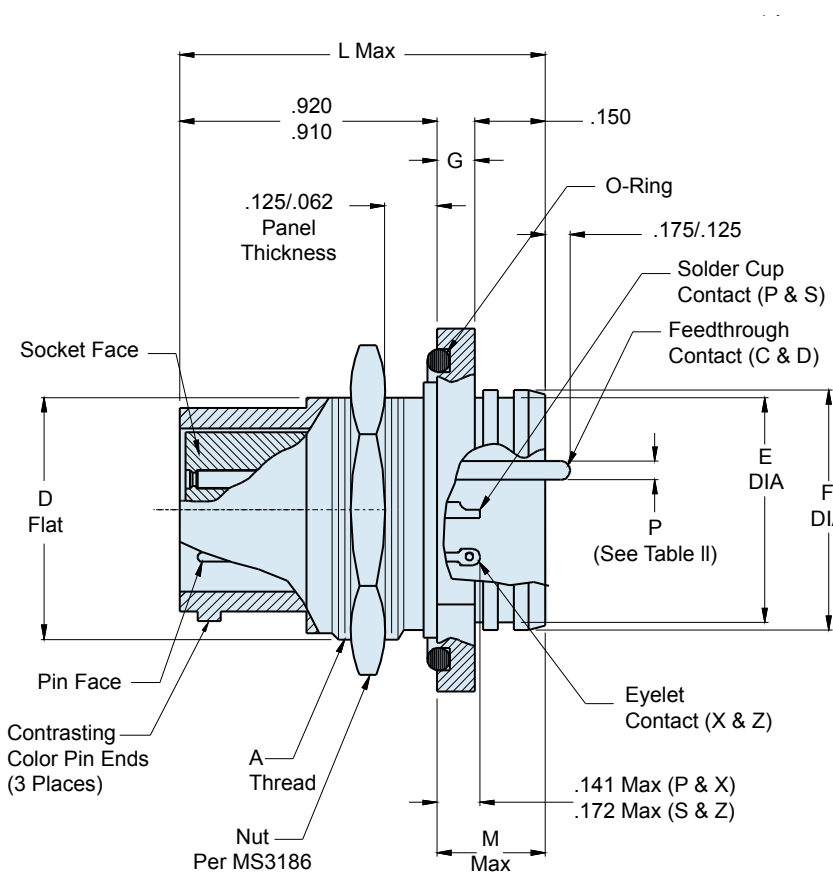
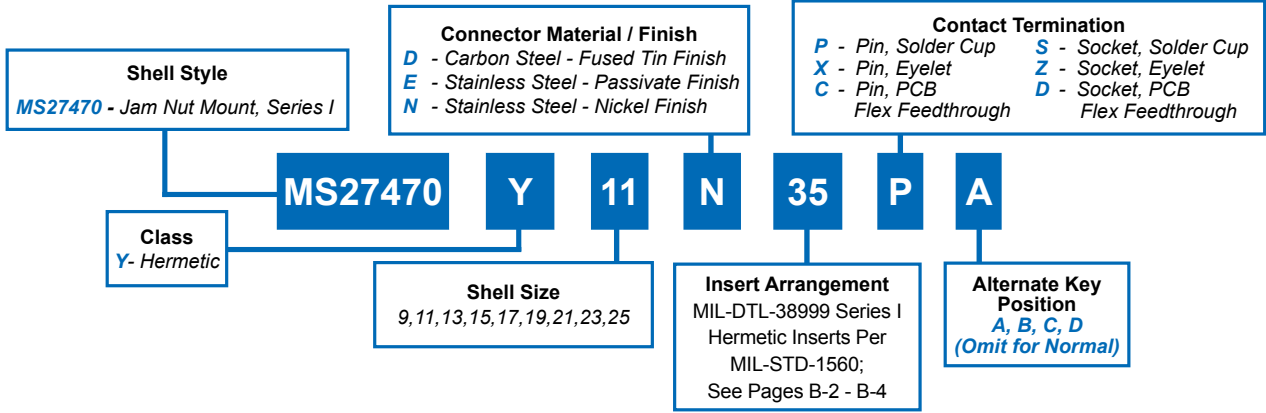

Dimensions in Inches (millimeters) are subject to change without notice.

© 2013 Glenair, Inc. U.S. CAGE Code 06324 Printed in U.S.A.

**GLENAIR, INC. • 1211 AIR WAY • GLENDALE, CA 91201-2497 • 818-247-6000 • FAX 818-500-9912**  
**www.glenair.com** **B-18** **E-Mail: sales@glenair.com**

Rev 03/02/2018

# 231-100-H7 Jam Nut Mount Hermetic Receptacle MIL-DTL-38999 Series I Type



## How To Order: Commercial

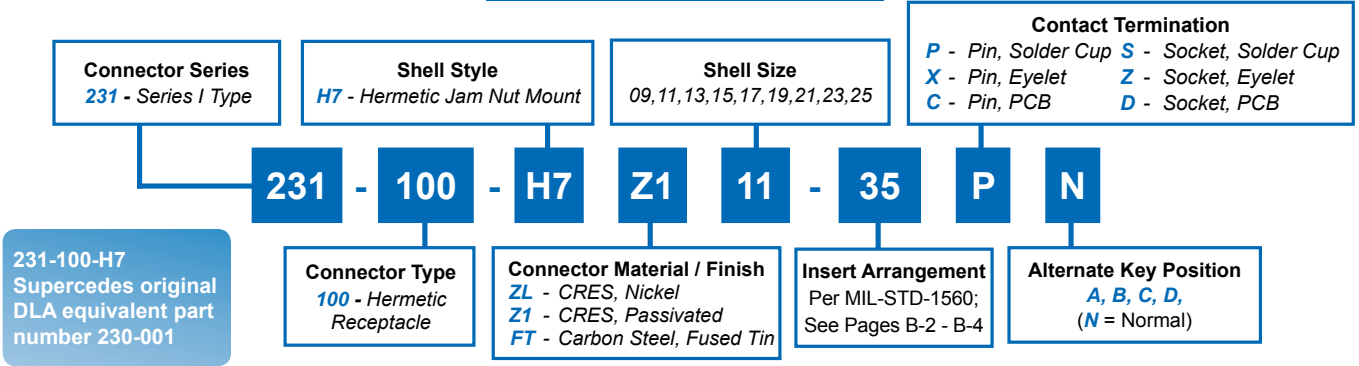

TABLE I: CONNECTOR DIMENSIONS

SHELL SIZE	A THREAD CLASS 2A	B DIA ±.016(0.4)	C ±.016(0.4)	D FLAT ±.005(0.1)	E DIA ±.011(0.3)	F DIA ±.005(0.1)
9/09	.6875-24 UNEF	1.188(30.2)	1.062(27.0)	.65(16.5)	.602(15.3)	.648(16.5)
11	.8125-20 UNEF	1.375(34.9)	1.25(31.8)	.75(19.1)	.726(18.4)	.772(19.6)
13	1.000-20 UNEF	1.5(38.1)	1.375(34.9)	.937(23.8)	.852(21.6)	.898(22.8)
15	1.125-18 UNEF	1.625(41.3)	1.5(38.1)	1.061(26.9)	.978(24.8)	1.024(26.0)
17	1.250-18 UNEF	1.75(44.5)	1.625(41.3)	1.186(30.1)	1.102(28.0)	1.148(29.2)
19	1.375-18 UNEF	1.938(49.2)	1.812(46.0)	1.311(33.3)	1.228(31.2)	1.274(32.4)
21	1.500-18 UNEF	2.062(52.4)	1.938(49.2)	1.436(36.5)	1.352(34.3)	1.398(35.5)
23	1.625-18 UNEF	2.188(55.6)	2.062(52.4)	1.561(39.6)	1.478(37.5)	1.524(38.7)
25	1.750-18 UNS	2.312(58.7)	2.188(55.6)	1.686(42.8)	1.602(40.7)	1.648(41.9)

TABLE I (CONTINUED): CONNECTOR DIMENSIONS

SHELL SIZE	G ±.016(0.4)	K DIA ±.005 (0.1)	L MAX	M MAX	N ± .005 (0.1)
9/09	.109 (2.8)	.693 (17.60)	1.200 (30.5)	.280 (7.1)	.657 (16.70)
11	.109 (2.8)	.825 (20.96)	1.200 (30.5)	.280 (7.1)	.771 (19.59)
13	.109 (2.8)	1.010 (25.65)	1.200 (30.5)	.280 (7.1)	.955 (24.26)
15	.109 (2.8)	1.135 (28.83)	1.200 (30.5)	.280 (7.1)	1.085 (27.56)
17	.109 (2.8)	1.260 (32.01)	1.200 (30.5)	.280 (7.1)	1.210 (30.73)
19	.140 (3.6)	1.385 (35.18)	1.231 (31.3)	.311 (7.9)	1.335 (33.91)
21	.140 (3.6)	1.510 (38.35)	1.231 (31.3)	.311 (7.9)	1.460 (37.08)
23	.140 (3.6)	1.635 (41.53)	1.231 (31.3)	.311 (7.9)	1.585 (40.26)
25	.140 (3.6)	1.760 (44.70)	1.231 (31.3)	.311 (7.9)	1.710 (43.43)

TABLE II: CONTACT SIZE

PRINTED CIRCUIT TAIL CONFIGURATIONS  
CONTACT STYLE C AND D

SIZE 12 AND SIZE 16

.050 ± .015 (1.27 ± 0.38)

SIZE 22D AND SIZE 20

Contact Size	ø P
22D	.011 (0.28) .015 (0.38)
20	.024 (0.61) .028 (0.71)
16	.0635 (1.61) .0615 (1.56)
12	.095 (2.41) .093 (2.36)

HERMETIC LEAK RATE MOD CODES

Designator	Required Leak Rate
-585A	1 x 10 <sup>-10</sup> cc Helium per second
-585B	1 x 10 <sup>-9</sup> cc Helium per second
-585C	1 x 10 <sup>-8</sup> cc Helium per second

WIRE ACCOMODATION

Contact Size	Wire Gauge
22D	#22 - #28
20	#20 - #24
16	#16 - #20
12	#12 - #14

Dimensions in Inches (millimeters) are subject to change without notice.



**MS27471**  
**Solder Mount Hermetic Receptacle**  
**MIL-DTL-38999 Series I**

**B**

**How To Order: MS**

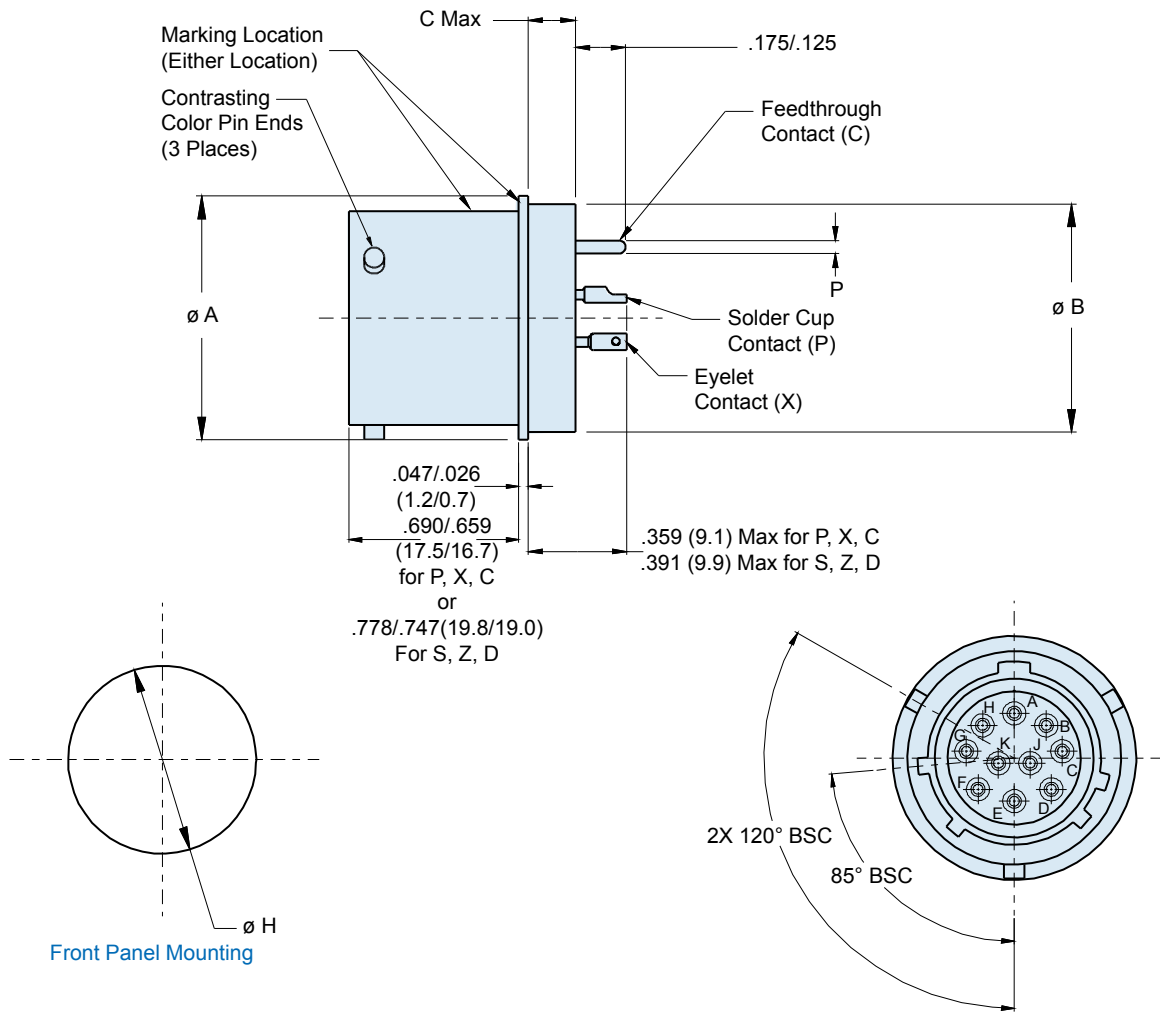
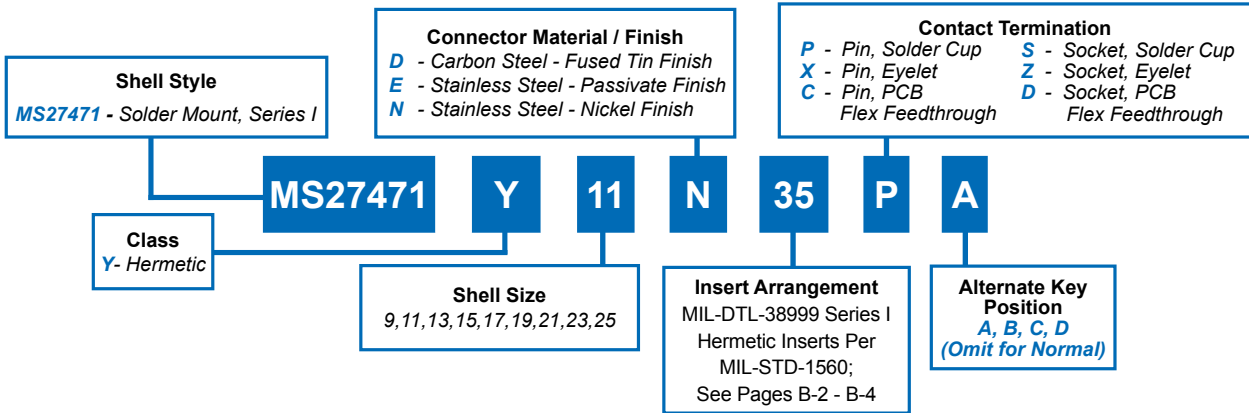

Dimensions in Inches (millimeters) are subject to change without notice.

# 231-100-H5 Solder Mount Hermetic Receptacle MIL-DTL-38999 Series I Type



## How To Order: Commercial

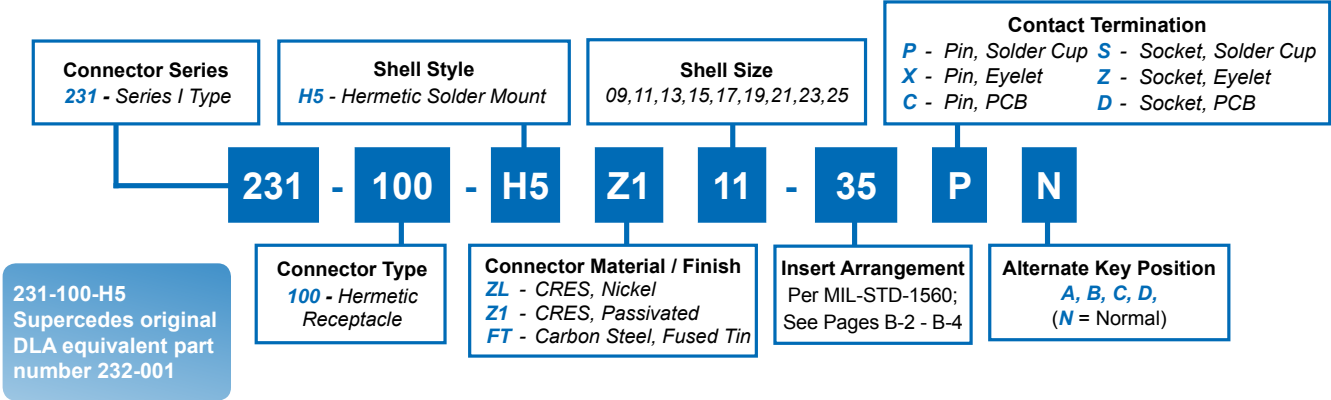

TABLE I: CONNECTOR DIMENSIONS				
SHELL SIZE	ø A ±.016(0.4)	ø B	C MAX	ø H ±.005(0.1)
9/09	.750(19.1)	.673(17.1) .667(16.9)	.187(4.7)	.680(17.3)
11	.844(21.4)	.782(19.9) .776(19.7)		.789(20.0)
13	.969(24.6)	.907(23.0) .901(22.9)		.914(23.2)
15	1.094(27.8)	1.032(26.2) 1.027(26.1)		1.038(26.4)
17	1.218(30.9)	1.157(29.4) 1.151(29.2)		1.164(29.6)
19	1.312(33.3)	1.251(31.8) 1.245(31.6)		1.258(32.0)
21	1.438(36.5)	1.376(35.0) 1.370(34.8)		1.383(35.1)
23	1.563(39.7)	1.501(38.1) 1.495(38.0)	.218(5.5)	1.508(38.3)
25	1.688(42.9)	1.626(41.3) 1.620(41.1)		1.643(41.7)

TABLE II: CONTACT SIZE	
PRINTED CIRCUIT TAIL CONFIGURATIONS CONTACT STYLE C AND D	
<b>Contact Size</b>	<b>ø P</b>
22D	.011 (0.28) .015 (0.38)
20	.024 (0.61) .028 (0.71)
16	.0635 (1.61) .0615 (1.56)
12	.095 (2.41) .093 (2.36)

HERMETIC LEAK RATE MOD CODES	
Designator	Required Leak Rate
-585A	1 x 10 <sup>-10</sup> cc Helium per second
-585B	1 x 10 <sup>-9</sup> cc Helium per second
-585C	1 x 10 <sup>-8</sup> cc Helium per second

WIRE ACCOMODATION	
Contact Size	Wire Gauge
22D	#22 - #28
20	#20 - #24
16	#16 - #20
12	#12 - #14

Dimensions in Inches (millimeters) are subject to change without notice.



**231-103-H7**  
**Jam Nut Mount Hermetic Bulkhead Feed-Thru**  
MIL-DTL-38999 Series I Type

**B**

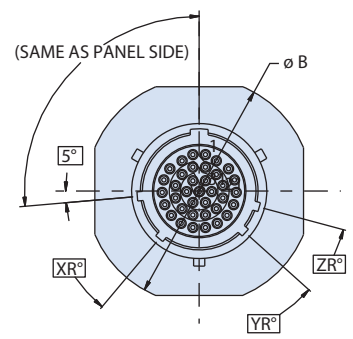
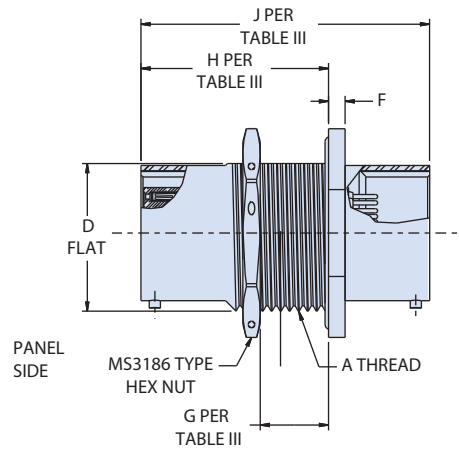
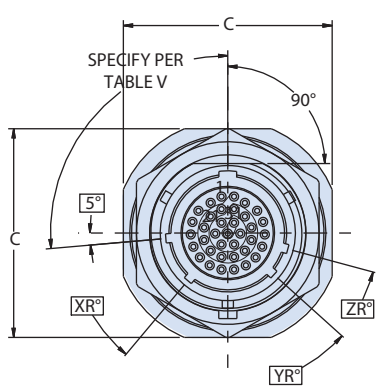
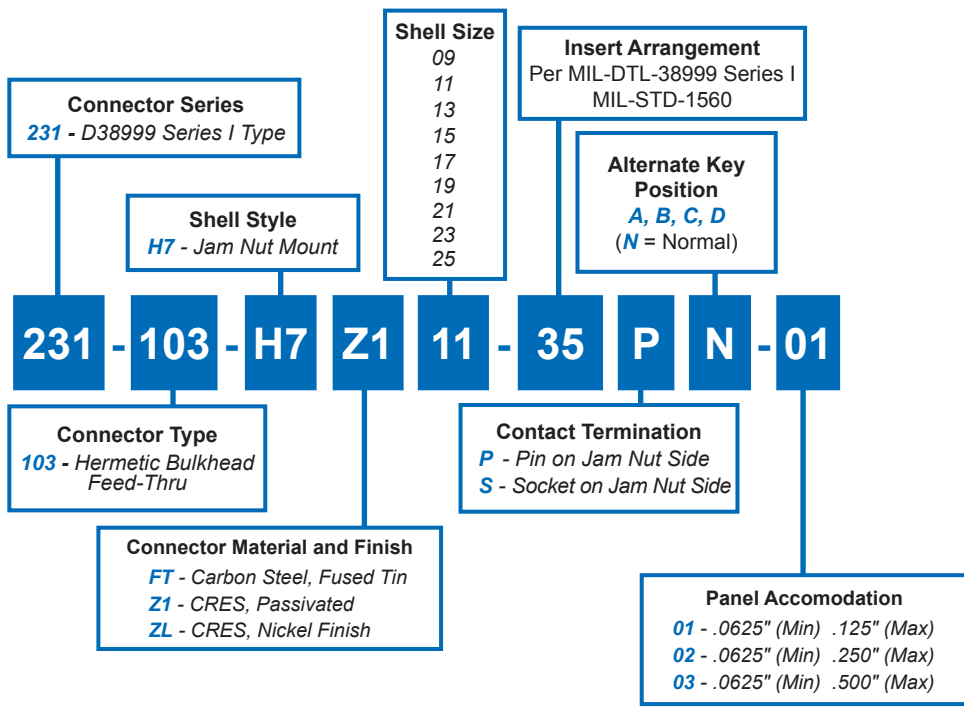

HERMETIC LEAK RATE MOD CODES	
Designator	Required Leak Rate
-585A	1 x 10 <sup>-10</sup> cc Helium per second
-585B	1 x 10 <sup>-9</sup> cc Helium per second
-585C	1 x 10 <sup>-8</sup> cc Helium per second

TABLE III: KEYWAY POSITIONS			
SYM	G	H	J
01	.125-.125	.920 MAX	1.700 MAX
02	.250-.250	1.060 MAX	1.650 MAX
03	.062-.500	1.310 MAX	2.100 MAX

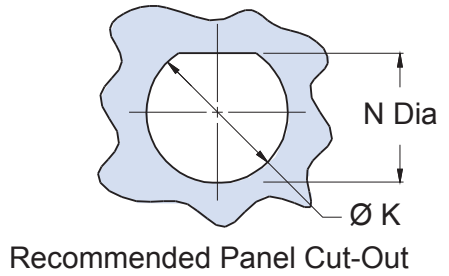

Dimensions in Inches (millimeters) are subject to change without notice.



**231-103-H7**  
**Jam Nut Mount Hermetic Bulkhead Feed-Thru**  
**MIL-DTL-38999 Series I Type**



**TABLE I: CONNECTOR DIMENSIONS**

SHELL SIZE	A THREAD CLASS 2A	B DIA MAX	C A/F	D FLATS	F	ØK	N
09	.6875-24 UNEF	1.204 (30.58) 1.172 (29.77)	1.078 (27.38) 1.046 (26.57)	0.655 (16.64) 0.645 (16.38)	0.125 (3.18) 0.093 (2.36)	0.703 (17.86) 0.693 (17.60)	0.661 (16.79) 0.653 (16.59)
11	.8125-20 UNEF	1.391 (35.33) 1.359 (34.52)	1.266 (32.16) 1.234 (31.34)	0.755 (19.18) 0.745 (18.92)	0.125 (3.18) 0.093 (2.36)	0.835 (21.21) 0.825 (20.96)	0.771 (19.58) 0.761 (19.33)
13	1.000-20 UNEF	1.516 (38.51) 1.484 (37.69)	1.391 (35.33) 1.359 (34.52)	0.942 (23.93) 0.932 (23.67)	0.125 (3.18) 0.093 (2.36)	1.020 (25.91) 1.010 (25.65)	0.955 (24.26) 0.945 (24.00)
15	1.125-18 UNEF	1.641 (41.68) 1.609 (40.87)	1.516 (38.51) 1.484 (37.69)	1.066 (27.08) 1.056 (26.82)	0.125 (3.18) 0.093 (2.36)	1.145 (29.08) 1.135 (28.83)	1.085 (27.56) 1.075 (27.30)
17	1.250-18 UNEF	1.766 (44.86) 1.734 (44.04)	1.641 (41.68) 1.609 (40.87)	1.191 (30.25) 1.181 (30.00)	0.125 (3.18) 0.093 (2.36)	1.270 (32.26) 1.260 (32.00)	1.210 (30.73) 1.200 (30.48)
19	1.375-18 UNEF	1.954 (49.63) 1.922 (48.82)	1.828 (46.43) 1.796 (45.62)	1.316 (33.43) 1.306 (33.17)	0.156 (3.96) 0.124 (3.15)	1.395 (35.43) 1.385 (35.18)	1.335 (33.91) 1.325 (33.65)
21	1.500-18 UNEF	2.078 (52.78) 2.046 (51.97)	1.954 (49.63) 1.922 (48.82)	1.441 (36.60) 1.431 (36.35)	0.156 (3.96) 0.124 (3.15)	1.520 (38.61) 1.510 (38.35)	1.460 (37.08) 1.450 (36.83)
23	1.625-18 UNEF	2.204 (55.98) 2.172 (55.17)	2.078 (52.78) 2.046 (51.97)	1.566 (39.78) 1.556 (39.52)	0.156 (3.96) 0.124 (3.15)	1.645 (41.78) 1.635 (41.53)	1.585 (40.26) 1.575 (40.00)
25	1.750-18 UNS	2.328 (59.13) 2.296 (58.32)	2.204 (55.98) 2.172 (55.17)	1.691 (42.95) 1.681 (42.70)	0.156 (3.96) 0.124 (3.15)	1.770 (44.96) 1.760 (44.70)	1.710 (43.43) 1.700 (43.18)

**TABLE II: KEYWAY POSITIONS**

Shell Size	XR	YR	ZR	Master Keyway Positions				
				N	A	B	C	D
9	45°	88°	27°	95°	77°	---	---	113°
11	45°	88°	27°	95°	81°	67°	123°	109°
13	45°	88°	27°	95°	75°	63°	127°	115°
15	45°	88°	27°	95°	74°	61°	129°	116°
17	45°	88°	27°	95°	77°	65°	125°	113°
19	45°	88°	27°	95°	77°	65°	125°	113°
21	45°	88°	27°	95°	77°	65°	125°	113°
23	45°	88°	27°	95°	80°	69°	121°	110°
25	45°	88°	27°	95°	80 <sup>a</sup>	69°	121°	110°

**APPLICATION NOTES**

<ol style="list-style-type: none"> <li>Power to a given contact on one end will result in power to contact directly opposite, regardless of identification letter.</li> <li>Hermeticity = less than <math>1 \times 10^{-7}</math> cc/sec at one atmosphere. Not for use in liquid atmosphere.</li> <li>Material/finish: Shell, nut – CRES/passivated, carbon steel/fused tin or CRES/nickel per QQ-N-290.</li> </ol>	<ol style="list-style-type: none"> <li>Contacts – Gold Plated. Pin: alloy 52; Skt.: copper alloy Insulator – fused vitreous glass/N.A. Seals – fluorosilicone rubber/N.A.</li> <li>Metric dimensions (mm) are indicated in parentheses.</li> </ol>
--	--

Dimensions in Inches (millimeters) are subject to change without notice.



**231-103-H9**  
**Sav-Con® Jam Nut Mount Hermetic Bulkhead Feed-Thru**  
**MIL-DTL-38999 Series I Type**

**B**

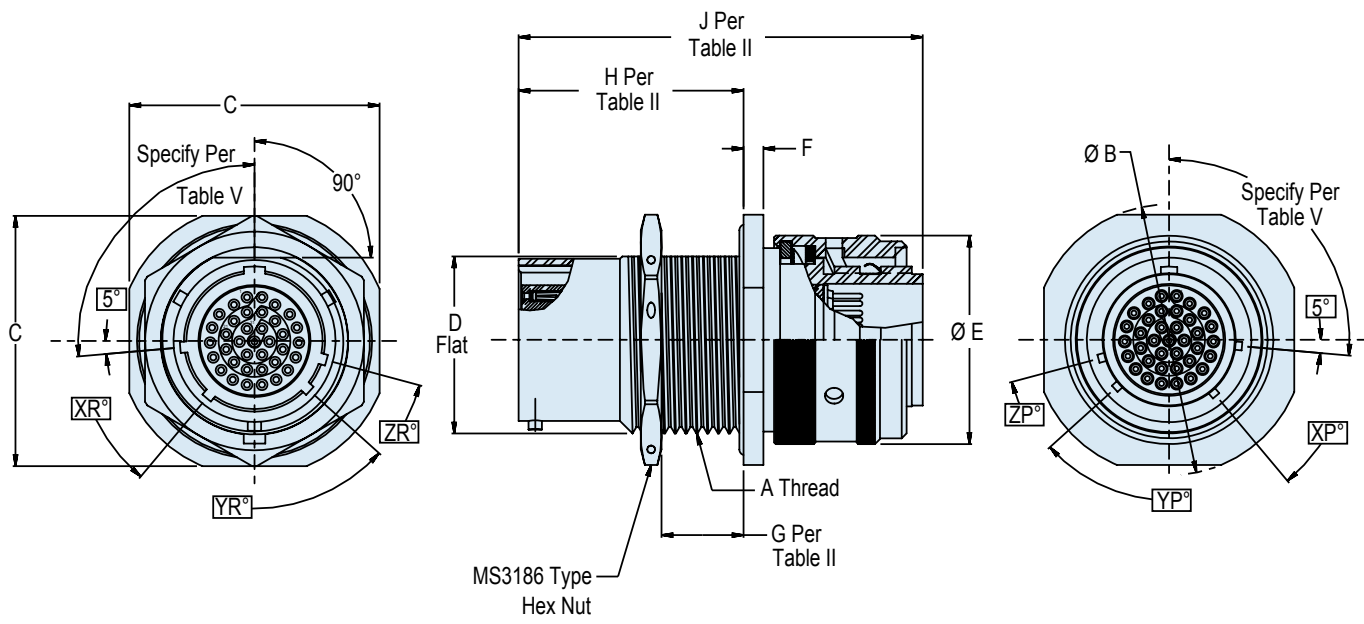
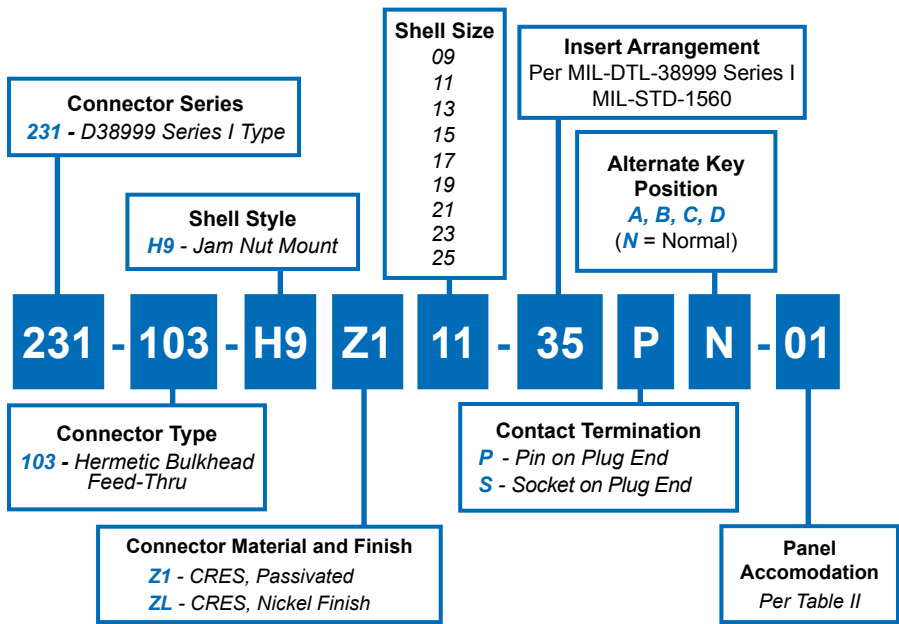

Dimensions in Inches (millimeters) are subject to change without notice.

# 231-103-H9

## Sav-Con® Jam Nut Mount Hermetic Bulkhead Feed-Thru MIL-DTL-38999 Series I Type



MIL-DTL-38999 Type  
Hermetic Connectors

B

**TABLE I: CONNECTOR DIMENSIONS**

SHELL SIZE	A THREAD CLASS 2A	B DIA MAX	C A/F	D FLAT	E DIA MAX	F	K DIA	N
09	.6875-24 UNEF	1.204/1.172 (30.58/29.77)	1.078/1.046 (27.38/26.57)	.655/.645 (16.64/16.38)	.859 (21.82)	.125/.093 (3.18/2.36)	.703/.693 (17.86/17.60)	.657/.655 (16.69/16.64)
11	.8125-20 UNEF	1.391/1.359 (35.33/34.52)	1.299/1.234 (32.99/31.34)	.755/.745 (19.18/18.92)	.984 (24.99)	.125/.093 (3.18/2.36)	.835/.825 (21.21/20.96)	.771/.769 (19.58/19.53)
13	1.000-20 UNEF	1.516/1.484 (38.51/37.69)	1.391/1.359 (35.33/34.52)	.942/.932 (23.93/23.67)	1.156 (29.36)	.125/.093 (3.18/2.36)	1.020/1.010 (25.91/25.65)	.955/.953 (24.26/24.21)
15	1.125-18 UNEF	1.641/1.609 (41.68/40.87)	1.516/1.484 (38.51/37.69)	1.066/1.056 (27.08/26.82)	1.281 (32.54)	.125/.093 (3.18/2.36)	1.145/1.135 (29.08/28.83)	1.085/1.083 (27.56/27.51)
17	1.250-18 UNEF	1.766/1.734 (44.86/44.04)	1.641/1.609 (41.68/40.87)	1.191/1.181 (30.35/30.00)	1.406 (35.71)	.125/.093 (3.18/2.36)	1.270/1.260 (32.26/32.00)	1.210/1.208 (30.73/30.68)
19	1.375-18 UNEF	1.954/1.922 (49.63/48.82)	1.828/1.796 (46.43/45.62)	1.316/1.306 (33.43/33.17)	1.516 (38.5)	.156/.124 (3.96/3.15)	1.395/1.385 (35.43/35.18)	1.335/1.333 (33.91/33.86)
21	1.500-18 UNEF	2.078/2.046 (52.78/51.97)	1.954/1.922 (49.63/48.82)	1.441/1.431 (36.60/36.35)	1.641 (41.68)	.156/.124 (3.96/3.15)	1.520/1.510 (38.61/38.35)	1.460/1.458 (37.08/37.03)
23	1.625-18 UNEF	2.204/2.172 (55.98/55.17)	2.078/2.046 (52.78/51.97)	1.566/1.556 (39.78/39.52)	1.766 (44.86)	.156/.124 (3.96/3.15)	1.645/1.635 (41.8/41.53)	1.585/1.583 (40.26/40.21)
25	1.750-18 UNS	2.328/2.296 (59.13/58.32)	2.204/2.172 (55.98/55.17)	1.691/1.681 (42.95/42.70)	1.891 (48.03)	.156/.124 (3.96/3.15)	1.770/1.760 (44.96/44.70)	1.710/1.708 (43.43/43.38)

**TABLE IV: MASTER KEY/KEYWAY POSITIONS**

SHELL SIZE	XP YP	YP YR	ZP ZR	N	A	B	C	D
09	45°	88°	27°	95°	77°	—	—	113°
11	45°	88°	27°	95°	81°	67°	123°	109°
13	45°	88°	27°	95°	75°	63°	127°	115°
15	45°	88°	27°	95°	74°	61°	129°	116°
17	45°	88°	27°	95°	77°	65°	125°	113°
19	45°	88°	27°	95°	77°	65°	125°	113°
21	45°	88°	27°	95°	77°	65°	125°	113°
23	45°	88°	27°	95°	80°	69°	121°	110°
25	45°	.88°	27°	95°	80°	69°	121°	110°

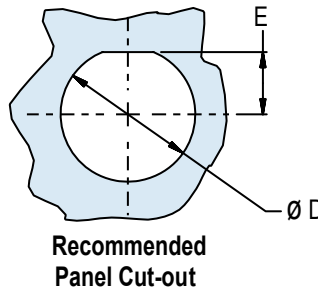

**TABLE III: DWV VOLTAGE LEVELS**

SERVICE RATING	VOLTAGE AC RMS 60HZ
M	1300 VAC
I	1800 VAC
II	2300 VAC
N	1000 VAC

**HERMETIC LEAK RATE MOD CODES**

Designator	Required Leak Rate
-585A	1 x 10 <sup>-10</sup> cc Helium per second
-585B	1 x 10 <sup>-9</sup> cc Helium per second
-585C	1 x 10 <sup>-8</sup> cc Helium per second

**TABLE II: DIMENSIONS**

SYM	G	H	J
01	.062-.125 (1.57-3.18)	.920 MAX (23.37 MAX)	2.050 MAX (52.07 MAX)
02	.062-.250 (1.57-6.35)	1.050 MAX (26.67 MAX)	2.150 MAX (54.61 MAX)
03	.062-.500 (1.57-12.7)	1.300 MAX (33.02 MAX)	2.400 MAX (60.96 MAX)

### APPLICATION NOTES

- Material/finish:  
Shell, jam-nut – 300 Series CRES/see P/N development.  
Contacts, pin – Nickel-iron alloy/Gold plate.  
Contacts, socket – Copper alloy/Gold plate.  
Insulator, pin – Vitreous glass/N.A.  
Insulator, sockets – HI-grade rigid dielectric/N.A.  
Grounding springs – Copper alloy/Gold plate.  
O-Rings and seals – Fluorosilicone blend/N.A.
- Assembly identified with manufacturer's name and part number, space permitting.
- Test requirements:  
D.W.V. – Per Table IV  
I.R. – 5 GigOhms @ 500 VDC  
Hermeticity – <1 x 10<sup>-7</sup> sccHe/sec @ 1 ATM differential.
- Metric dimensions (mm) are indicated in parentheses.

Dimensions in Inches (millimeters) are subject to change without notice.



257-255

**Jam Nut Mount Hermetic Receptacle  
with Crimp Removable Socket Contacts,  
MIL-DTL-38999 Series I Type**

B

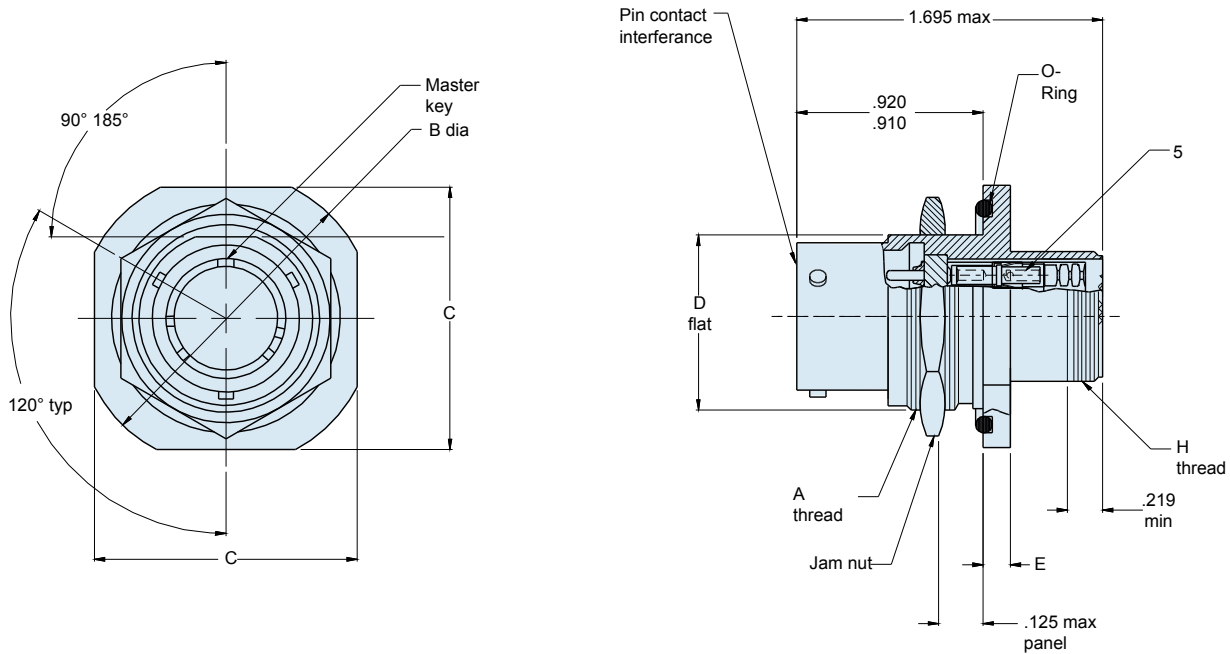
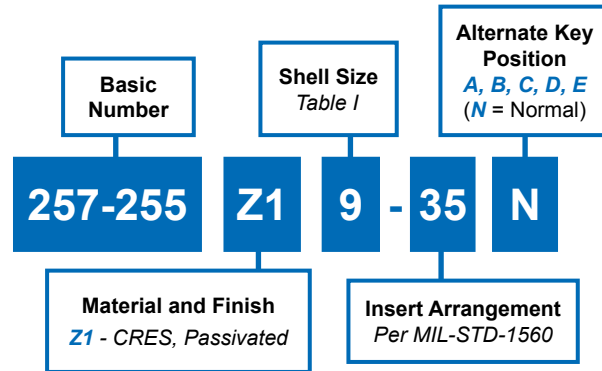

**APPLICATION NOTES**

- |   |   |
|---|---|
| <ol style="list-style-type: none"> <li>1. Assembly identified with manufacturer's name and part number, space permitting.</li> <li>2. Insert arrangements in accordance with MIL-STD-1560.</li> <li>3. Glenair 257-255 receptacle connector is designed to mate with any QPL manufacturer's MIL-DTL-38999 Series I plug connector having the same insert arrangement &amp; polarization.</li> <li>4. Material/finish:<br/>Shell, jam nut—CRES/passivated</li> </ol> | <ol style="list-style-type: none"> <li>5. Supplied crimp removal socket contacts conform to M39029/57</li> <li>6. Metric Dimensions (mm) are indicated in parentheses.</li> </ol> <p>Pin contacts—nickel-iron alloy 52/gold<br/>         Socket contacts—copper alloy/gold<br/>         Insulator—fused vitreous glass/N.A.<br/>         Insulators—high grade rigid dielectric/ N.A.<br/>         Seals—pure fluorosilicone rubber/ N.A.</p> |
|---|---|

Dimensions in Inches (millimeters) are subject to change without notice.

**257-255**  
**Jam Nut Mount Hermetic Receptacle**  
 with Crimp Removable Socket Contacts,  
 MIL-DTL-38999 Series I Type



**B**

HERMETIC LEAK RATE MOD CODES	
Designator	Required Leak Rate
-585A	1 x 10 <sup>-10</sup> cc Helium per second
-585B	1 x 10 <sup>-9</sup> cc Helium per second
-585C	1 x 10 <sup>-8</sup> cc Helium per second

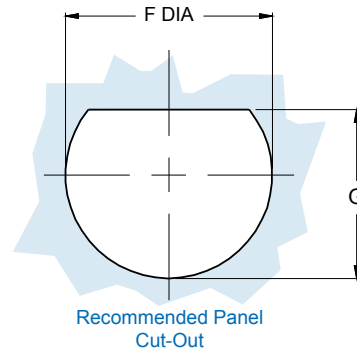

TABLE I: CONNECTOR DIMENSIONS				
SHELL SIZE	A THREAD CLASS 2A	B DIA ±.016(0.4)	C FLATS ±.016(0.4)	D FLAT ±.005(0.1)
9	.6875-24 UNEF	1.188(30.2)	1.062(27.0)	.650(16.5)
11	.8125-20 UNEF	1.375(34.9)	1.250(31.8)	.750(19.1)
13	1.000-20 UNEF	1.500(38.1)	1.375(34.9)	.937(23.8)
15	1.125-18 UNEF	1.625(41.3)	1.500(38.1)	1.061(26.9)
17	1.250-18 UNEF	1.750(44.5)	1.625(41.3)	1.186(30.1)
19	1.375-18 UNEF	1.938(49.2)	1.812(46.0)	1.311(33.3)
21	1.500-18 UNEF	2.062(52.4)	1.938(49.2)	1.436(36.5)
23	1.625-18 UNEF	2.188(55.6)	2.062(52.4)	1.561(39.6)
25	1.750-18 UNS	2.312(58.7)	2.188(55.6)	1.686(42.8)

TABLE I (CONTINUED): CONNECTOR DIMENSIONS				
SHELL SIZE	E DIA ±.016(0.4)	F DIA ±.005 (0.1)	G ±.005 (0.1)	H THREAD CLASS 2A
9	.109(2.8)	.693 (17.60)	.657 (16.70)	.4375-28 UNEF
11	.109(2.8)	.825 (20.96)	.771 (19.59)	.5625-24 UNEF
13	.109(2.8)	1.010 (25.65)	.955 (24.26)	.6875-24 UNEF
15	.109(2.8)	1.135 (28.83)	1.085 (27.56)	.8125-20 UNEF
17	.140(3.6)	1.260 (32.01)	1.210 (30.73)	.9375-20 UNEF
19	.140(3.6)	1.385 (35.18)	1.335 (33.91)	1.0625-18 UNEF
21	.140(3.6)	1.510 (38.35)	1.460 (37.08)	1.1875-18 UNEF
23	.140(3.6)	1.635 (41.53)	1.585 (40.26)	1.3125-18 UNEF
25	.140(3.6)	1.760 (44.70)	1.710 (43.43)	1.4375-18 UNEF

Dimensions in Inches (millimeters) are subject to change without notice.





# 947-117 Jam Nut Mount Hermetic Bulkhead Feed-Thru for MIL-DTL-38999 Series I Type

**B**

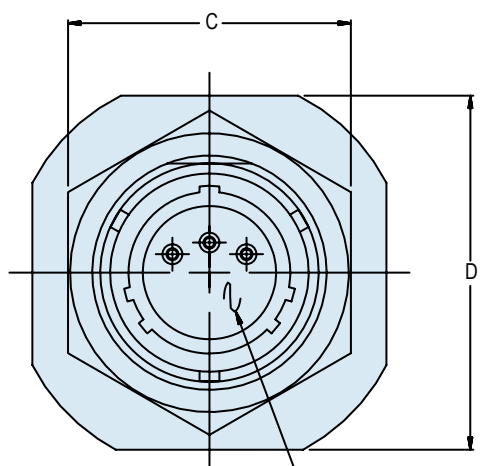
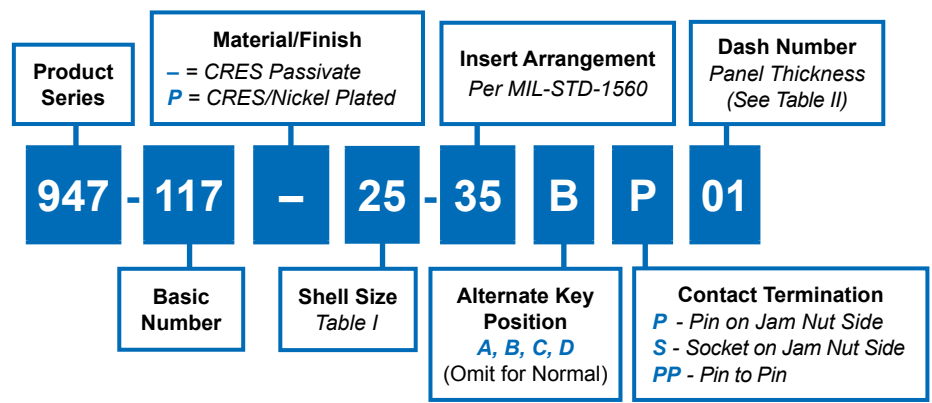

Insert Arrangement, Per Mil-c-38999, Series I

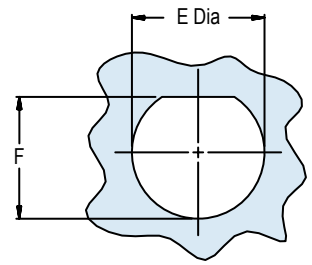
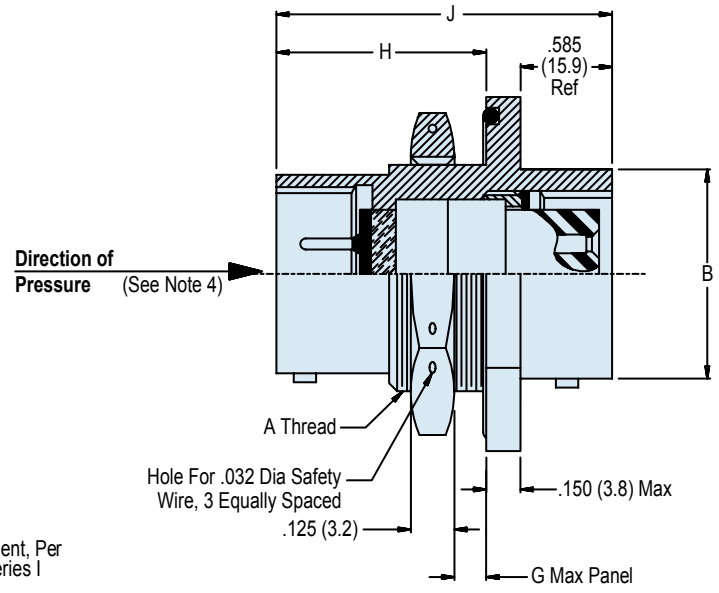

Recommended Panel Cut-out

Dimensions in Inches (millimeters) are subject to change without notice.

**947-117**  
**Jam Nut Mount Hermetic Bulkhead Feed-Thru**  
**for MIL-DTL-38999 Series I Type**



**TABLE I: CONNECTOR DIMENSIONS**

Shell Size	A Thread Class 2A	B Dia Max	C Hex	D Flats	E Dia ± .005 (0.13)	F +.000 -.005 (+0.0 -0.13)
9	11/16-24 UNEF	.573 (14.6)	.875 (22.1)	1.062 (27.0)	.703 (17.9)	.669 (17.0)
11	13/16-20 UNEF	.701 (17.8)	1.000 (25.4)	1.250 (31.8)	.827 (21.0)	.769 (19.5)
13	1-20 UNEF	.851 (21.6)	1.188 (30.2)	1.375 (34.9)	1.015 (25.8)	.955 (24.3)
15	1 1/8-18 UNEF	.976 (24.8)	1.312 (33.3)	1.500 (38.1)	1.140 (29.0)	1.084 (27.5)
17	1 1/4-18 UNEF	1.101 (28.0)	1.438 (37.7)	1.625 (41.3)	1.265 (32.1)	1.208 (30.7)
19	1 3/8-18 UNEF	1.208 (30.7)	1.562 (39.7)	1.812 (46.0)	1.390 (35.3)	1.333 (33.9)
21	1 1/2-18 UNEF	1.333 (33.9)	1.688 (42.9)	1.938 (49.2)	1.515 (38.5)	1.459 (37.1)
23	1 5/8-18 UNEF	1.458 (37.0)	1.812 (46.0)	2.062 (52.4)	1.640 (41.7)	1.580 (40.1)
25	1 3/4-18 UNS	1.583 (40.2)	2.000 (50.8)	2.188 (55.6)	1.765 (44.8)	1.709 (43.4)

**TABLE II: PANEL THICKNESS**

DASH NO	G MAX	H MAX	J MAX
01	.250 (6.4)	1.060 (26.9)	1.790 (45.5)
02	.500 (12.7)	1.310 (33.3)	2.040 (51.8)
03	.750 (19.1)	1.560 (39.6)	2.290 (58.2)
04	1.000 (25.4)	1.810 (46.0)	2.540 (64.5)

**APPLICATION NOTES**

1. Assembly identified with manufacturer's name and PN, space permitting.
2. For pin/pin and skt/skt, symmetrical layouts only, consult factory for available insert arrangements.
3. Power to a given contact on one end will result in power to contact directly opposite, regardless of identification letter.
4. Hermeticity = less than  $1 \times 10^{-7}$  cc/sec at one atmosphere. Not for use in liquid atmosphere.
5. Electrical safety limits must be established by user, peak voltage, switching surge, transient, etc. should be used to determine the safety of the application.
6. Material/finish:  
 Shell, lock ring, jam nut—CRES/see part no. development.  
 Contacts—copper alloy/gold plate and alloy 52/gold plate  
 Insulators—high-grade rigid dielectric/N.A. and full glass.  
 Seals—fluorosilicone/ N.A.
7. Metric dimensions (mm) are indicated in parentheses.

Dimensions in Inches (millimeters) are subject to change without notice.



# MS27475 Wall Mount Hermetic Receptacle MIL-DTL-38999 Series II

## How To Order: MS

<b>Shell Style</b> MS27475 - Wall Mount, Series II	<b>Connector Material / Finish</b> D - Carbon Steel - Fused Tin Finish E - Stainless Steel - Passivate Finish N - Stainless Steel - Nickel Finish	<b>Contact Termination</b> P - Pin, Solder Cup    S - Socket, Solder Cup X - Pin, Eyelet        Z - Socket, Eyelet C - Pin, PCB            D - Socket, PCB Flex Feedthrough        Flex Feedthrough
---	--	---

<b>Class</b> Y - Hermetic	MS27475	Y	10	N	35	P	A
<b>Shell Size</b> 8, 10, 12, 14, 16, 18, 20, 22, 24		<b>Insert Arrangement</b> MIL-DTL-38999 Series II Hermetic Inserts Per MIL-STD-1560; See Pages B-2 - B4		<b>Alternate Key Position</b> A, B, C, D (Omit for Normal)			

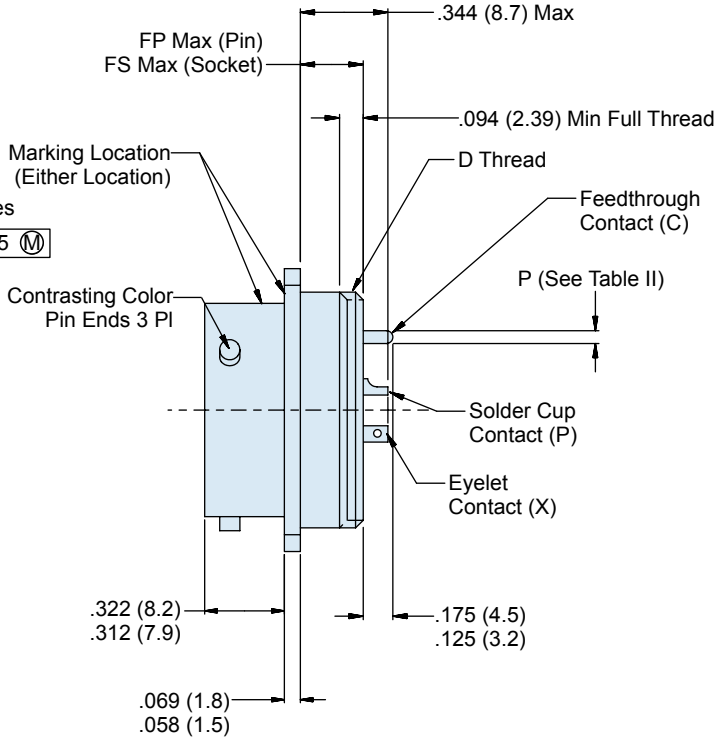
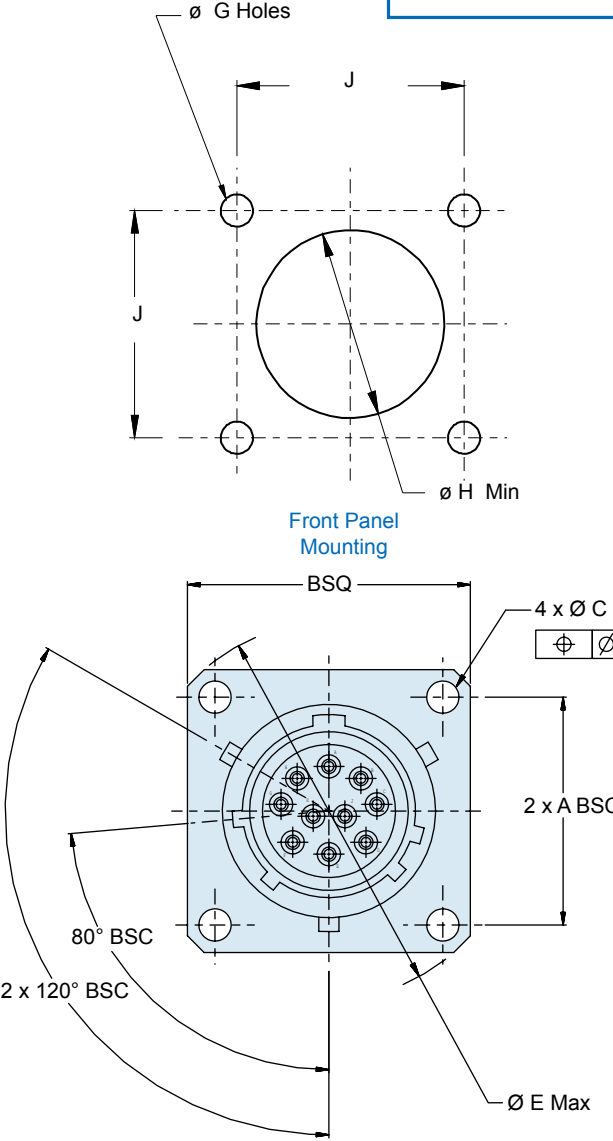

Dimensions in Inches (millimeters) are subject to change without notice.

# 232-100-H0

## Wall Mount Hermetic Receptacle

### MIL-DTL-38999 Series II Type



### How To Order: Commercial

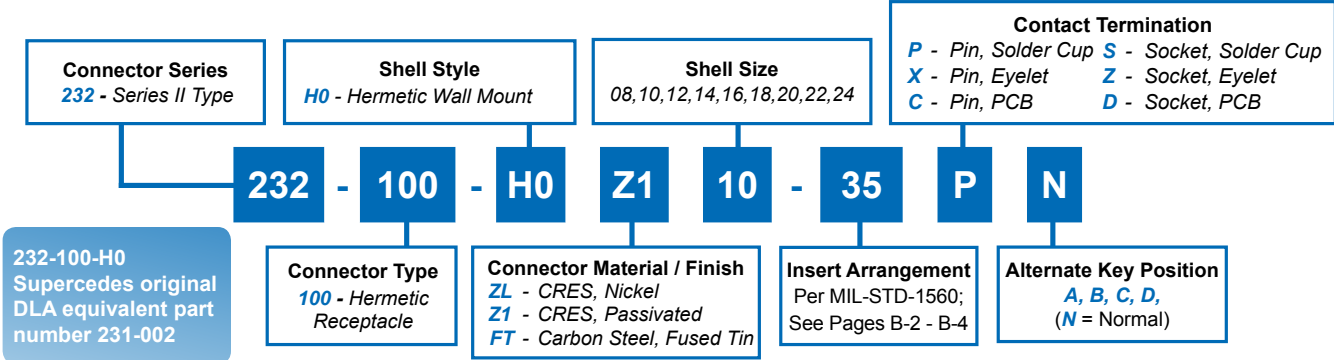

232-100-H0  
Supercedes original  
DLA equivalent part  
number 231-002

SHELL SIZE	A BSC	B SQ MAX	Ø C HOLES	D Threads (UNEF-2A)	Ø E MAX	FP MAX	FS MAX
8/08	.594(15.1)	.828(21.0)	.130(3.3) .115(2.9)	.5625-24	1.078(27.4)	.250 (6.35)	.375 (9.5)
10	.719(18.3)	.954(24.2)		.6875-24	1.256(31.9)		
12	.812(20.6)	1.047(26.6)		.8125-20	1.391(35.3)		
14	.906(23.0)	1.141(29.0)		.9375-20	1.516(38.5)		
16	.969(24.6)	1.234(31.3)		1.0625-18	1.641(41.7)		
18	1.062(27.0)	1.328(33.7)		1.1875-18	1.766(44.9)		
20	1.156(29.4)	1.453(36.9)		1.3125-18	1.891(48.0)		
22	1.250(31.8)	1.578(40.1)		1.4375-10	2.016(51.2)		
24	1.375(34.9)	1.703(43.3)	.157(4.0) .142(3.6)	1.5625-18	2.204(56.0)	.375 (9.53)	.406 (10.3)

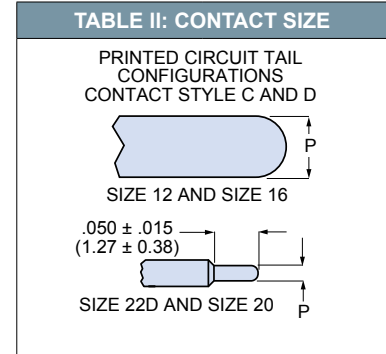

Contact Size	Ø P
22D	.011 (0.28) .015 (0.38)
20	.024 (0.61) .028 (0.71)
16	.0635 (1.61) .0615 (1.56)
12	.095 (2.41) .093 (2.36)

SHELL SIZE	Ø G HOLES	Ø H MIN	Ø J BSC
8	.133(3.4) .123(3.1)	.570(14.5)	.594(15.1)
10		.690(17.5)	.719(18.3)
12		.820(20.8)	.812(20.6)
14		.940(23.9)	.906(23.0)
16		1.070(27.2)	.969(24.6)
18		1.190(30.2)	1.062(27.0)
20		1.320(33.5)	1.156(29.4)
22		.159(4.0)	1.440(36.6)
24	.149(3.8)	1.570(39.9)	1.375(34.9)

Contact Size	Wire Gauge
22D	#22 - #28
20	#20 - #24
16	#16 - #20
12	#12 - #14

Designator	Required Leak Rate
-585A	1 x 10 <sup>-10</sup> cc Helium per second
-585B	1 x 10 <sup>-9</sup> cc Helium per second
-585C	1 x 10 <sup>-8</sup> cc Helium per second

Dimensions in Inches (millimeters) are subject to change without notice.



**MS27476**  
**Box Mount Hermetic Receptacle**  
**MIL-DTL-38999 Series II**

**How To Order: MS**

**B**

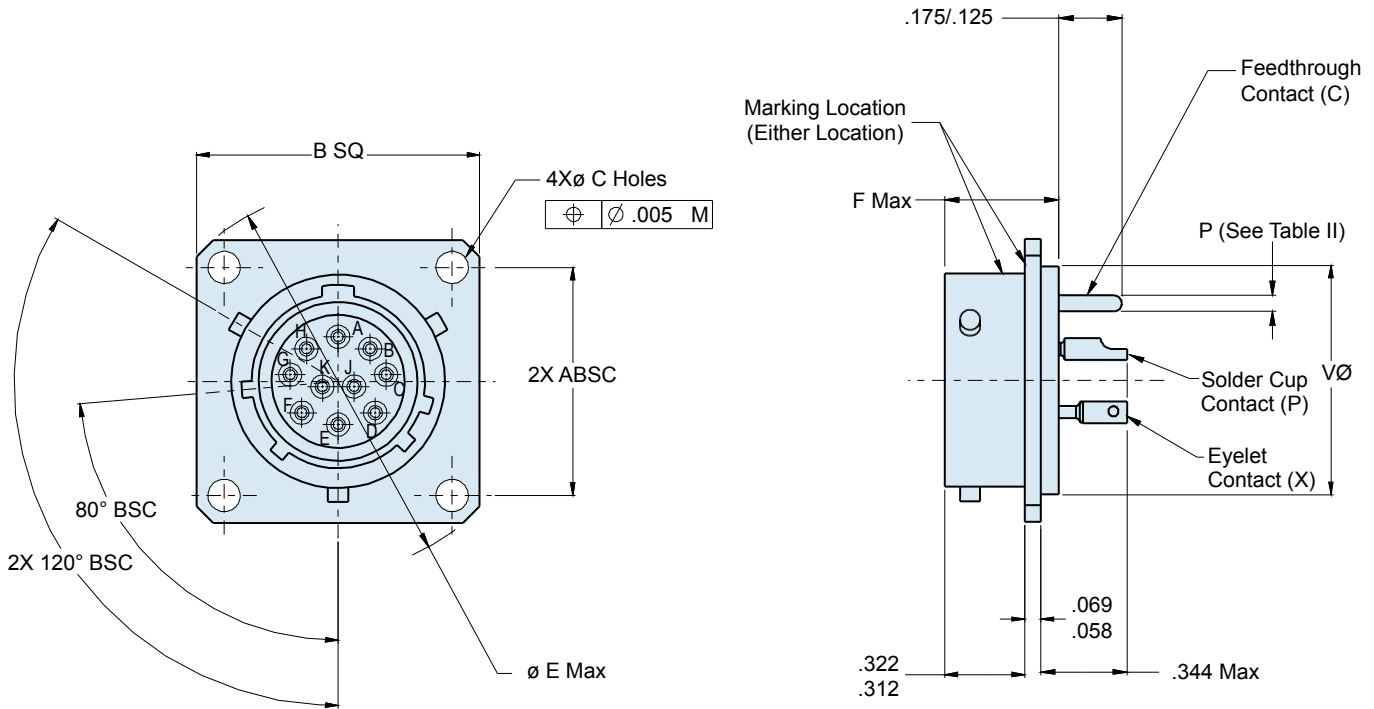
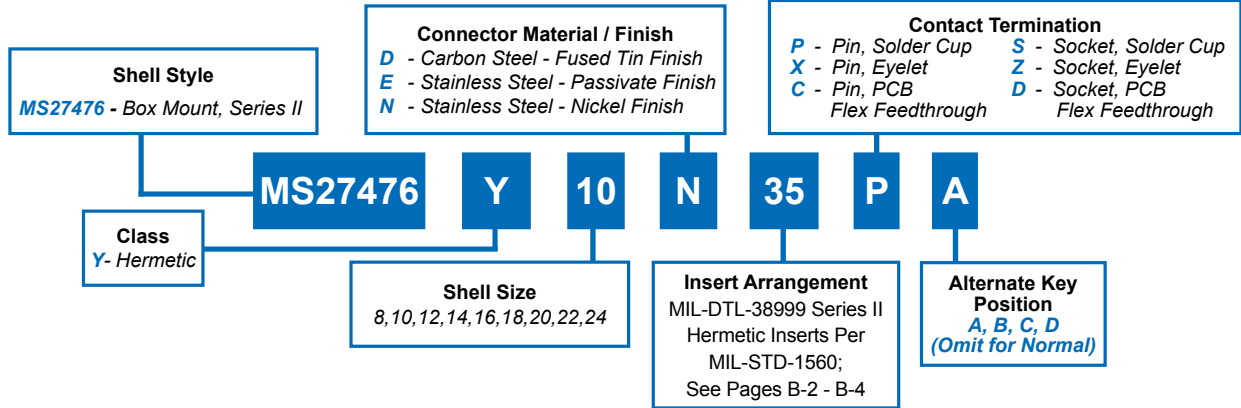

Dimensions in Inches (millimeters) are subject to change without notice.



# 232-100-H2 Box Mount Hermetic Receptacle MIL-DTL-38999 Series II Type



## How To Order: Commercial

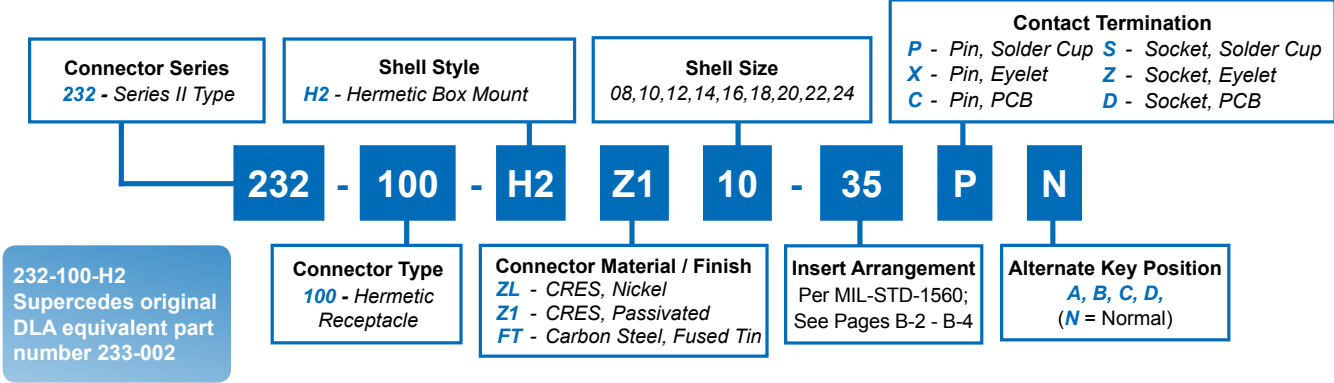

SHELL SIZE	A BSC	B SQ MAX	Ø C HOLES	Ø E MAX	F MAX	V Diameter
8/08	.594(15.1)	.828(21.0)	.130(3.3) .115(2.9)	1.078(27.4)	.453(11.5)	.562(14.3)
10	.719(18.3)	.954(24.2)		1.266(32.2)		.672(17.1)
12	.812(20.6)	1.047(26.6)		1.391(35.3)		.781(19.8)
14	.906(23.0)	1.141(29.0)		1.516(38.5)		.906(23.0)
16	.969(24.6)	1.234(31.3)		1.641(41.7)		1.031(26.2)
18	1.062(27.0)	1.328(33.7)		1.766(44.9)		1.156(29.4)
20	1.156(29.4)	1.453(36.9)		1.891(48.0)		1.250(31.8)
22	1.250(31.8)	1.578(40.1)		2.016(51.2)		1.375(34.9)
24	1.375(34.9)	1.703(43.3)	.157(4.0) .142(3.6)	2.204(56.0)	.484(12.3)	1.500(38.1)

Contact Size	Ø P
22D	.011 (0.28) .015 (0.38)
20	.024 (0.61) .028 (0.71)
16	.0635 (1.61) .0615 (1.56)
12	.095 (2.41) .093 (2.36)

PRINTED CIRCUIT TAIL CONFIGURATIONS  
CONTACT STYLE C AND D

SIZE 12 AND SIZE 16

SIZE 22D AND SIZE 20

SHELL SIZE	Ø G HOLES	Ø H MIN	Ø J BSC
8/08	.133(3.4) .123(3.1)	.570(14.5)	.594(15.1)
10		.690(17.5)	.719(18.3)
12		.820(20.8)	.812(20.6)
14		.940(23.9)	.906(23.0)
16		1.070(27.2)	.969(24.6)
18		1.190(30.2)	1.062(27.0)
20		1.320(33.5)	1.156(29.4)
22		.159(4.0)	1.440(36.6)
24	.149(3.8)	1.570(39.9)	1.375(34.9)

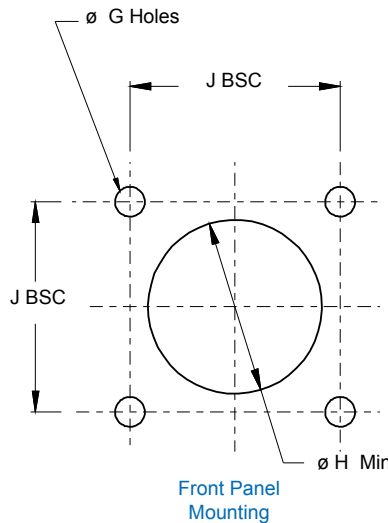

Designator	Required Leak Rate
-585A	1 x 10 <sup>-10</sup> cc Helium per second
-585B	1 x 10 <sup>-9</sup> cc Helium per second
-585C	1 x 10 <sup>-8</sup> cc Helium per second

Contact Size	Wire Gauge
22D	#22 - #28
20	#20 - #24
16	#16 - #20
12	#12 - #14

Dimensions in Inches (millimeters) are subject to change without notice.



# MS27477

## Jam Nut Mount Hermetic Receptacle

### MIL-DTL-38999 Series II

#### How To Order: MS

**B**

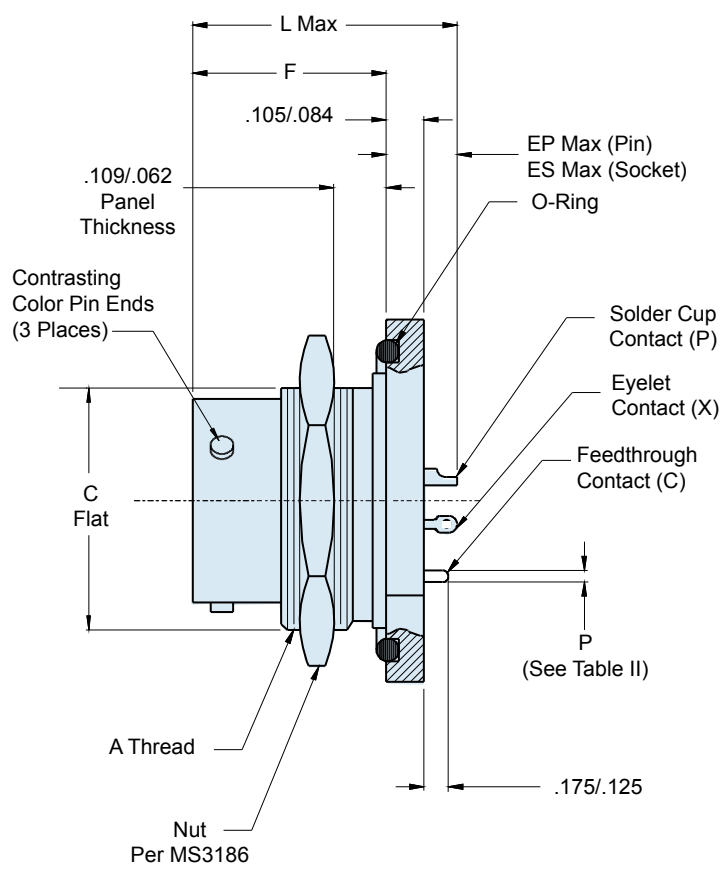
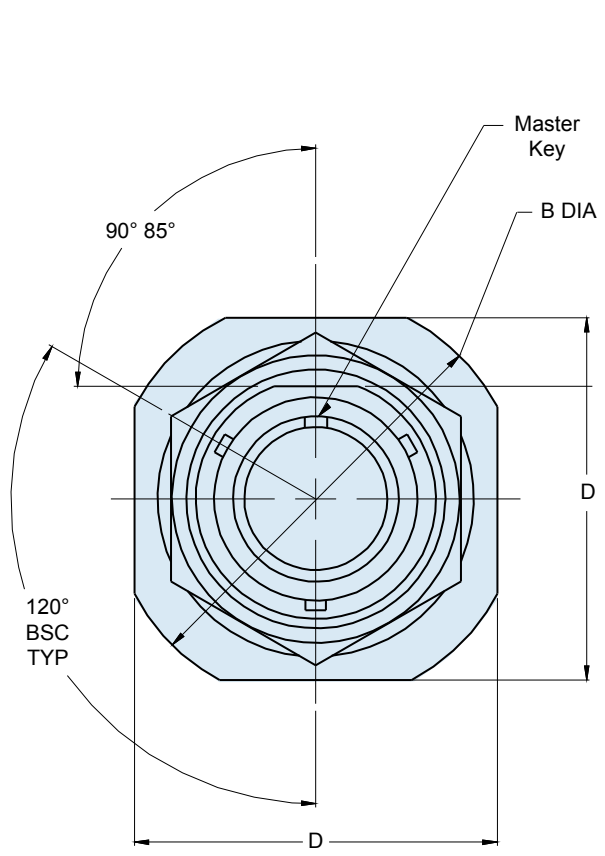
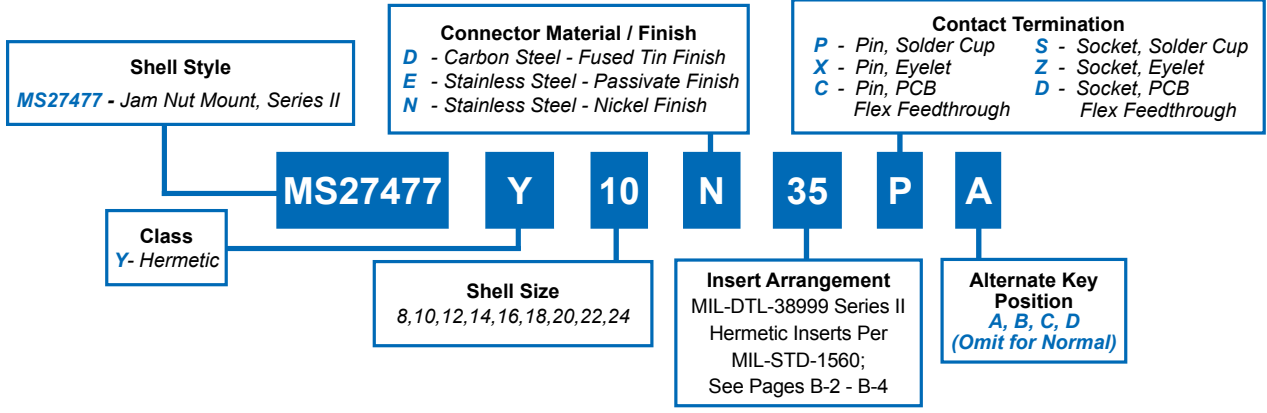

Dimensions in Inches (millimeters) are subject to change without notice.

© 2013 Glenair, Inc. U.S. CAGE Code 06324 Printed in U.S.A.

**GLENAIR, INC. • 1211 AIR WAY • GLENDALE, CA 91201-2497 • 818-247-6000 • FAX 818-500-9912**  
**www.glenair.com** **B-34** **E-Mail: sales@glenair.com**

Rev 03/02/2018

# 232-100-H7 Jam Nut Mount Hermetic Receptacle MIL-DTL-38999 Series II Type



## How To Order: Commercial

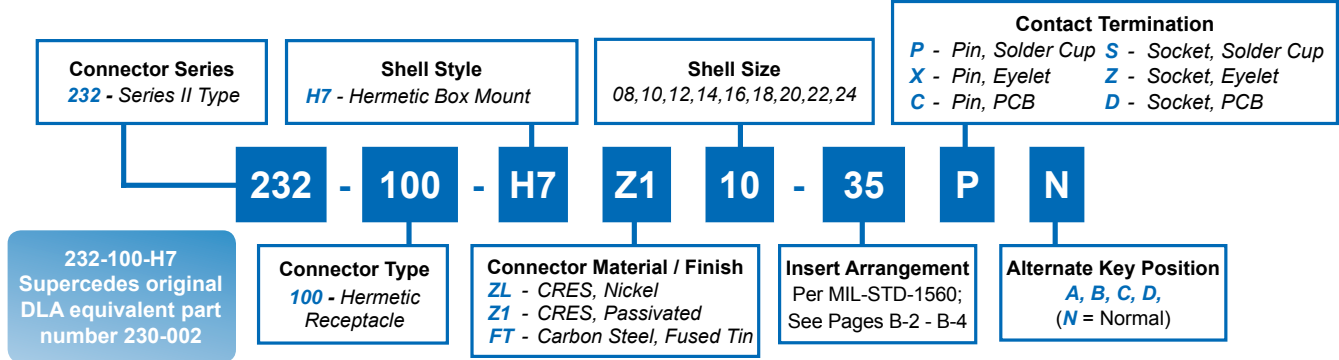

WIRE ACCOMODATION	
Contact Size	Wire Gauge
22D	#22 - #28
20	#20 - #24
16	#16 - #20
12	#12 - #14

HERMETIC LEAK RATE MOD CODES	
Designator	Required Leak Rate
-585A	1 x 10 <sup>-10</sup> cc Helium per second
-585B	1 x 10 <sup>-9</sup> cc Helium per second
-585C	1 x 10 <sup>-8</sup> cc Helium per second

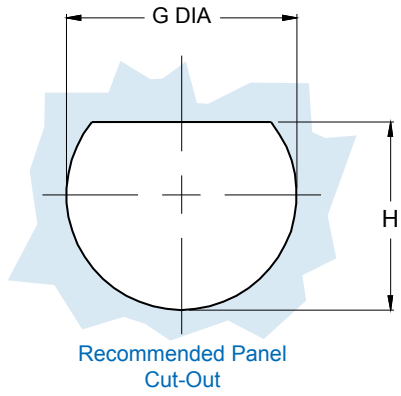

TABLE I: CONNECTOR DIMENSIONS				
SHELL SIZE	A THREAD CLASS 2A	B DIA ±.016(0.4)	C FLAT ±.004(0.1)	D A/F ±.016(0.4)
8/08	.875-20 UNEF	1.375(34.9)	.815(20.7)	1.25(31.8)
10	1.000-20 UNEF	1.5(38.1)	.939(23.9)	1.375(34.9)
12	1.125-18 UNEF	1.625(41.3)	1.063(27.0)	1.5(38.1)
14	1.250-18 UNEF	1.75(44.5)	1.188(30.2)	1.625(41.3)
16	1.375-18 UNEF	1.938(49.2)	1.318(33.5)	1.781(45.2)
18	1.500-18 UNEF	2.016(51.2)	1.438(36.5)	1.890(48.0)
20	1.625-18 UNEF	2.141(54.4)	1.563(39.7)	2.016(51.2)
22	1.750-18 UNS	2.265(57.5)	1.688(42.9)	2.140(54.4)
24	1.875-16 UN	2.39(60.7)	1.813(46.1)	2.265(57.5)

TABLE I (CONTINUED): CONNECTOR DIMENSIONS						
SHELL SIZE	EP MAX	ES MAX	F ±.005(0.1)	G DIA ±.005(0.1)	H ±.005(0.1)	L MAX
8/08	.281 (7.1)	.359 (9.1)	.438(11.1)	.885(22.48)	.830(21.08)	.724(18.4)
10	.281 (7.1)	.359 (9.1)	.438(11.1)	1.010(25.65)	.955(24.26)	.724(18.4)
12	.281 (7.1)	.359 (9.1)	.438(11.1)	1.135(28.83)	1.085(27.56)	.724(18.4)
14	.281 (7.1)	.359 (9.1)	.438(11.1)	1.260(32.01)	1.210(30.73)	.724(18.4)
16	.281 (7.1)	.359 (9.1)	.438(11.1)	1.385(35.18)	1.335(33.91)	.724(18.4)
18	.281 (7.1)	.359 (9.1)	.438(11.1)	1.510(38.35)	1.460(37.08)	.724(18.4)
20	.250 (6.4)	.344 (8.7)	.464(11.8)	1.635(41.53)	1.585(40.26)	.719(18.3)
22	.250 (6.4)	.344 (8.7)	.464(11.8)	1.760(44.70)	1.709(43.42)	.719(18.3)
24	.250 (6.4)	.344 (8.7)	.464(11.8)	1.885(47.88)	1.835(46.61)	.719(18.3)

TABLE II: CONTACT SIZE	
Contact Size	ø P
22D	.011 (0.28) .015 (0.38)
20	.024 (0.61) .028 (0.71)
16	.0635 (1.61) .0615 (1.56)
12	.095 (2.41) .093 (2.36)

PRINTED CIRCUIT TAIL CONFIGURATIONS CONTACT STYLE C AND D

SIZE 12 AND SIZE 16

SIZE 22D AND SIZE 20

Dimensions in Inches (millimeters) are subject to change without notice.



**MS27478**  
Solder Mount Hermetic Receptacle  
MIL-DTL-38999 Series II

**How To Order: MS**

**Shell Style**  
**MS27478** - Solder Mount, Series II

**Connector Material / Finish**  
D - Carbon Steel - Fused Tin Finish  
E - Stainless Steel - Passivate Finish  
N - Stainless Steel - Nickel Finish

**Contact Termination**  
P - Pin, Solder Cup     S - Socket, Solder Cup  
X - Pin, Eyelet         Z - Socket, Eyelet  
C - Pin, PCB            D - Socket, PCB  
                                   Flex Feedthrough     Flex Feedthrough

B

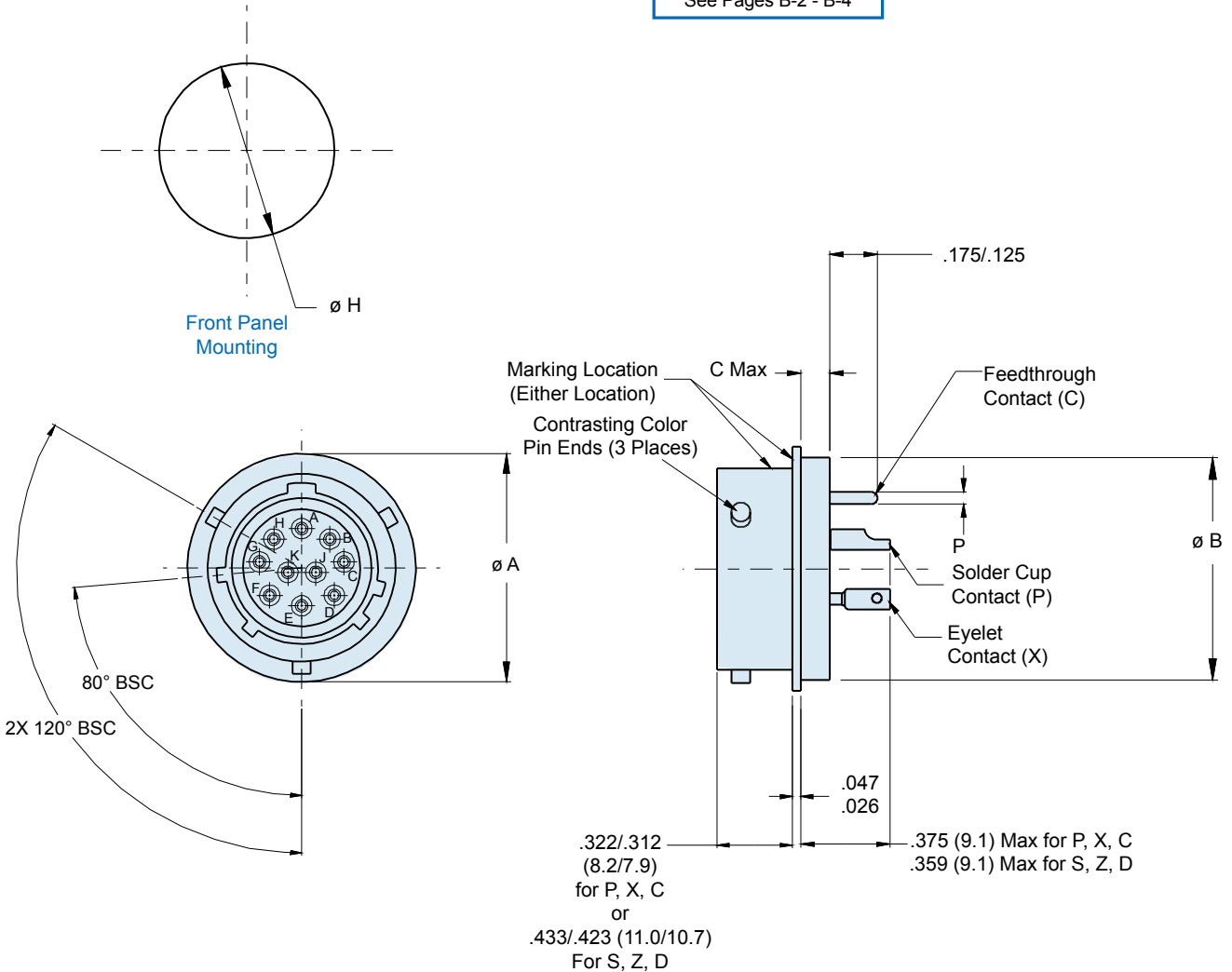
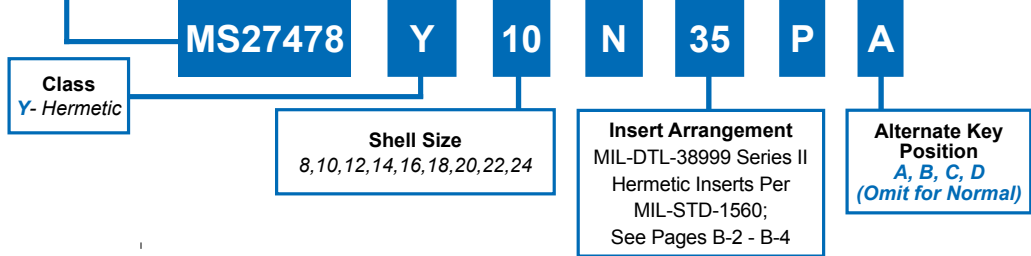

Dimensions in Inches (millimeters) are subject to change without notice.

# 232-100-H5 Solder Mount Hermetic Receptacle MIL-DTL-38999 Series II Type



## How To Order: Commercial

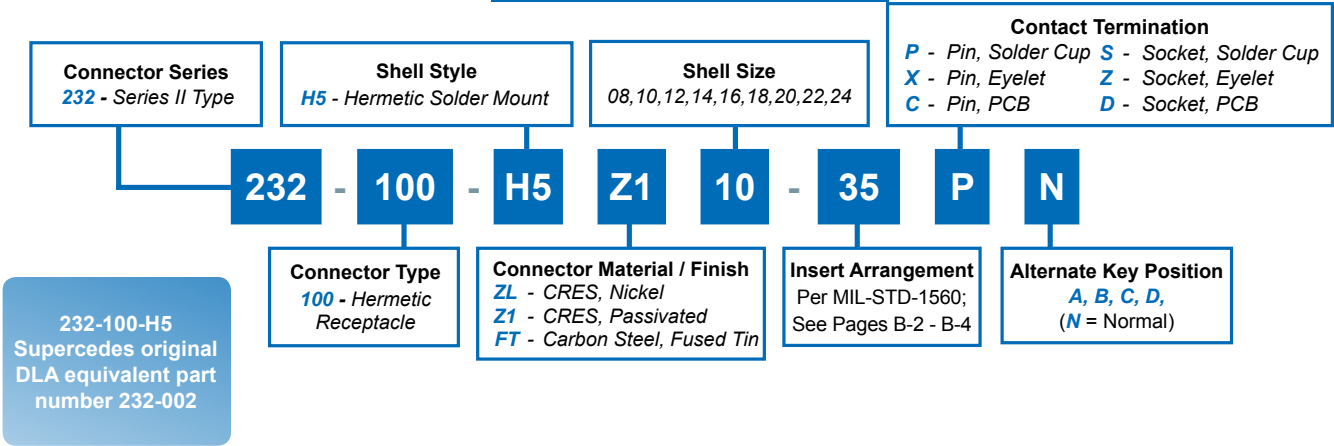

HERMETIC LEAK RATE MOD CODES	
Designator	Required Leak Rate
-585A	1 x 10 <sup>-10</sup> cc Helium per second
-585B	1 x 10 <sup>-9</sup> cc Helium per second
-585C	1 x 10 <sup>-8</sup> cc Helium per second

TABLE I: CONNECTOR DIMENSIONS				
SHELL SIZE	ø A ± .011 (0.3)	ø B	C MAX	ø H ±.005 (0.1)
8/08	.687 (17.45)	.563 (14.3) .557 (14.1)	.125 (3.2)	.570 (14.5)
10	.797 (20.2)	.673 (17.1) .667 (16.9)		.680 (17.3)
12	.906 (23.0)	.782 (19.9) .776 (19.7)		.789 (20.0)
14	1.031 (26.2)	.907 (23.0) .901 (22.9)		.914(23.2)
16	1.156 (29.4)	1.032 (26.2) 1.027 (26.1)		1.039 (26.4)
18	1.281 (32.5)	1.157 (29.4) 1.151 (29.2)		1.164 (29.6)
20	1.375 (34.9)	1.251 (31.8) 1.245 (31.6)	.156 (4.0)	1.258 (32.0)
22	1.500 (38.1)	1.376 (35.0) 1.370 (34.8)		1.383 (35.1)
24	1.625 (41.3)	1.501 (38.1)		1.508 (38.3)
		1.495 (38.0)		

TABLE II: CONTACT SIZE	
PRINTED CIRCUIT TAIL CONFIGURATIONS CONTACT STYLE C AND D	
<b>Contact Size</b>	<b>ø P</b>
22D	.011 (0.28) .015 (0.38)
20	.024 (0.61) .028 (0.71)
16	.0635 (1.61) .0615 (1.56)
12	.095 (2.41) .093 (2.36)

WIRE ACCOMODATION	
Contact Size	Wire Gauge
22D	#22 - #28
20	#20 - #24
16	#16 - #20
12	#12 - #14

Dimensions in Inches (millimeters) are subject to change without notice.





**232-103-H7**  
**Jam Nut Mount Hermetic Bulkhead Feed-Thru**  
 MIL-DTL-38999 Series II Type

**B**

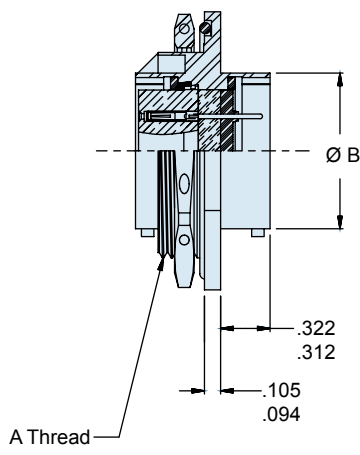
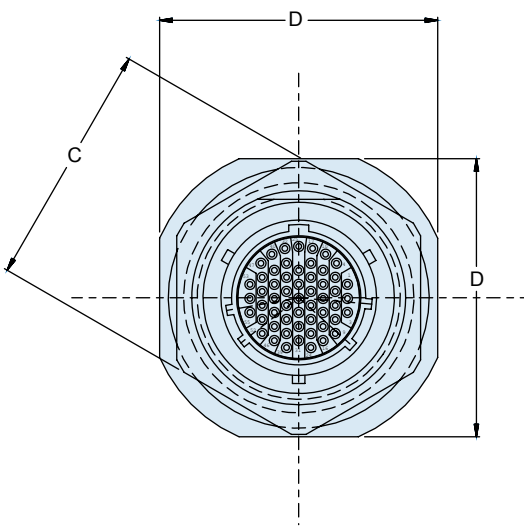
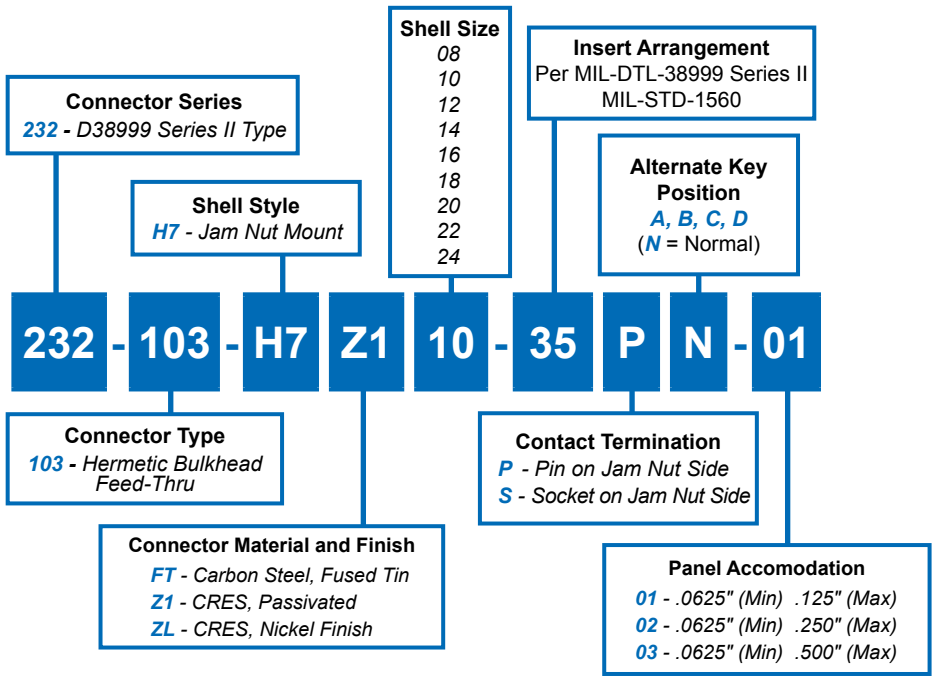

Dimensions in Inches (millimeters) are subject to change without notice.

232-103-H7  
Jam Nut Mount Hermetic Bulkhead Feed-Thru  
MIL-DTL-38999 Series II Type



TABLE I: CONNECTOR DIMENSIONS

SHELL SIZE	A THREAD CLASS 2A	B DIA MAX	C HEX	D FLATS	E DIA ±.005(0.1)	F +.000-.005 (0-0.1)
08	.875-20 UNEF	.474(12.0)	1.062(27.0)	1.250(31.8)	.885(22.5)	.830(21.1)
10	1.000-20 UNEF	.591(15.0)	1.188(30.2)	1.375(34.9)	1.010(25.7)	.955(24.3)
12	1.125-18 UNEF	.751(19.1)	1.312(33.3)	1.500(38.1)	1.135(28.8)	1.085(27.6)
14	1.250-18 UNEF	.876(22.3)	1.438(36.5)	1.625(41.3)	1.260(32.0)	1.210(30.7)
16	1.375-18 UNEF	1.001(25.4)	1.562(39.7)	1.781(45.2)	1.385(35.2)	1.335(33.9)
18	1.500-18 UNEF	1.126(28.6)	1.688(42.9)	1.890(48.0)	1.510(38.4)	1.460(37.1)
20	1.625-18 UNEF	1.251(31.8)	1.812(46.0)	2.016(51.2)	1.635(41.5)	1.585(40.3)
22	1.750-18 UNS	1.376(35.0)	2.000(50.8)	2.140(54.4)	1.760(44.7)	1.710(43.4)
24	1.875-16 UN	1.501(38.1)	2.125(54.0)	2.265(57.5)	1.885(47.9)	1.835(46.6)

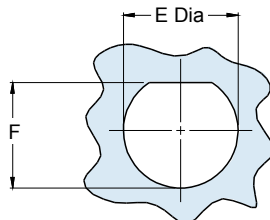

Recommended Panel Cut-Out

APPLICATION NOTES

- Power to a given contact on one end will result in power to contact directly opposite, regardless of identification letter.
- Hermeticity = less than  $1 \times 10^{-7}$  cc/sec at one atmosphere. Not for use in liquid atmosphere.
- Material/finish:  
Shell, nut – CRES/passivated, carbon steel/fused tin or CRES/nickel per QQ-N-290.
- Contacts – Gold Plated. Pin: alloy 52; Skt.: copper alloy  
Insulator – fused vitreous glass/N.A.  
Seals – fluorosilicone rubber/N.A.

Dimensions in Inches (millimeters) are subject to change without notice.



**232-103-H9**  
Jam Nut Mount Hermetic Bulkhead Feed-Thru  
Sav-Con® Connector Saver • MIL-DTL-38999 Series II Type

**B**

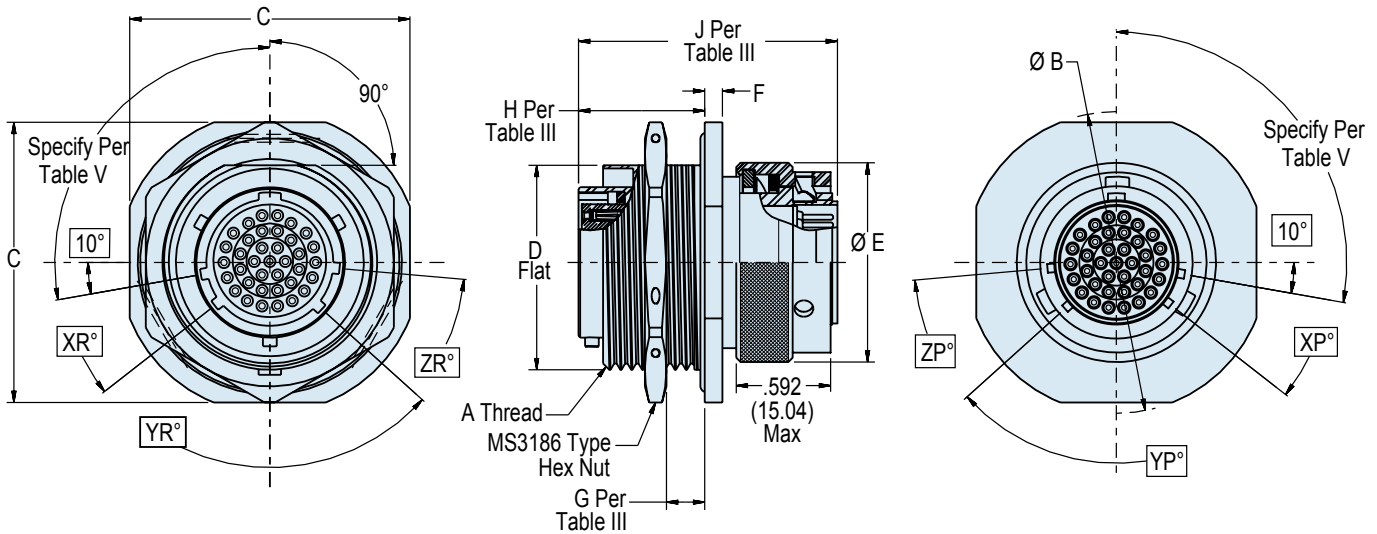
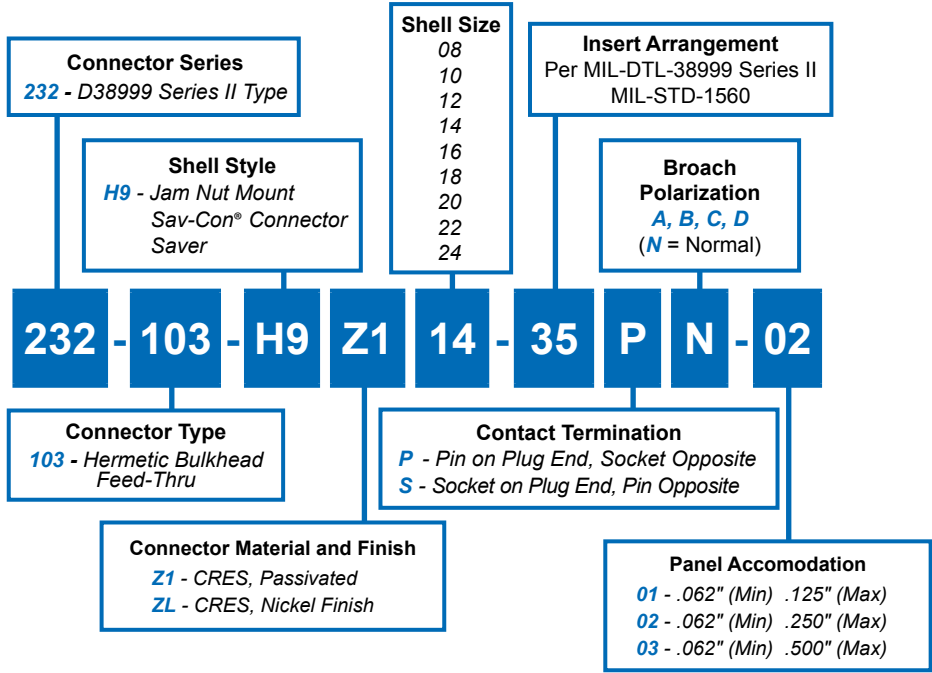

Dimensions in Inches (millimeters) are subject to change without notice.

# 232-103-H9

## Jam Nut Mount Hermetic Bulkhead Feed-Thru Sav-Con® Connector Saver • MIL-DTL-38999 Series II Type

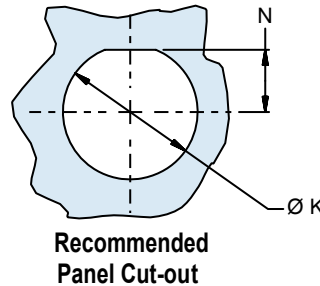

**TABLE I: CONNECTOR DIMENSIONS**

SHELL SIZE	A THREAD CLASS 2A	B DIA	C A/F	D FLAT	E DIA MAX	F	K DIA	N
<b>8</b>	.875-20 UNEF	1.391/1.359 (35.33/34.52)	1.266/1.234 (27.38/26.57)	.818/.811 (16.64/20.60)	.750 (19.05)	.105/.084 (2.67/2.13)	.895/ .885 (22.73/22.48)	.830/.820 (21.08/20.83)
<b>10</b>	1.000-20 UNEF	1.516/1.484 (38.51/37.69)	1.391/1.359 (35.33/34.52)	.942/.935 (19.18/23.75)	.859 (21.82)	.105/.084 (2.67/2.13)	1.020/1.010 (25.91/25.65)	.955/.945 (24.26/24.00)
<b>12</b>	1.125-18 UNEF	1.641/1.609 (41.68/40.87)	1.516/1.484 (38.51/37.69)	1.066/1.059 (27.08/26.90)	1.031 (26.19)	.105/.084 (2.67/2.13)	1.145/1.135 (29.08/28.83)	1.085/1.075 (27.56/27.31)
<b>14</b>	1.250-18 UNEF	1.766/1.734 (44.86/44.04)	1.641/1.609 (41.68/40.87)	1.191/1.184 (30.25/30.07)	1.156 (29.36)	.105/.084 (2.67/2.13)	1.270/1.260 (32.26/32.00)	1.210/1.200 (30.73/30.48)
<b>16</b>	1.375-18 UNEF	1.954/1.922 (49.63/48.82)	1.797/1.765 (45.64/44.83)	1.321/1.314 (33.55/33.38)	1.281 (32.54)	.105/.084 (2.67/2.13)	1.395/1.385 (35.43/35.18)	1.335/1.325 (33.91/33.66)
<b>18</b>	1.500-18 UNEF	2.032/2.000 (51.61/50.80)	1.906/1.874 (48.41/47.60)	1.441/1.434 (36.60/36.42)	1.406 (35.71)	.105/.084 (2.67/2.13)	1.520/1.510 (38.61/38.35)	1.460/1.450 (37.08/36.83)
<b>20</b>	1.625-18 UNEF	2.157/2.125 (54.79/53.98)	2.032/2.000 (51.61/50.80)	1.566/1.559 (39.78/39.60)	1.531 (38.89)	.105/.084 (2.67/2.13)	1.645/1.635 (41.78/41.53)	1.585/1.575 (40.26/40.01)
<b>22</b>	1.750-18 UNS	2.281/2.249 (57.94/57.12)	2.156/2.124 (54.76/53.95)	1.691/1.684 (42.95/42.77)	1.641 (41.68)	.105/.084 (2.67/2.13)	1.770/1.760 (44.96/44.70)	1.709/1.699 (43.41/43.15)
<b>24</b>	1.875-16 UN	2.406/2.374 (61.11/60.30)	2.281/2.249 (57.94/57.12)	1.816/1.809 (46.13/45.95)	1.766 (44.86)	.105/.084 (2.67/2.13)	1.895/1.885 (48.13/47.88)	1.855/1.825 (47.12/46.36)

**TABLE IV: MASTER KEY/KEYWAY POSITIONS**

SHELL SIZE	XP XR	YP YR	ZP ZR	N	A	B	C	D
<b>8</b>	28°	100°	37°	100°	82°	—	—	118°
<b>10</b>	28°	100°	37°	100°	86°	72°	128°	114°
<b>12</b>	28°	100°	37°	100°	80°	68°	132°	120°
<b>14</b>	28°	100°	37°	100°	79°	66°	134°	121°
<b>16</b>	28°	100°	37°	100°	82°	70°	130°	118°
<b>18</b>	28°	100°	37°	100°	82°	70°	130°	118°
<b>20</b>	28°	100°	37°	100°	82°	70°	130°	118°
<b>22</b>	28°	100°	37°	100°	85°	74°	126°	115°
<b>24</b>	28°	100°	37°	100°	85°	74°	126°	115°



**TABLE III: DWV VOLTAGE LEVELS**

SERVICE RATING	VOLTAGE AC RMS 60HZ
<b>M</b>	1300 VAC
<b>I</b>	1800 VAC
<b>II</b>	2300 VAC
<b>N</b>	1000 VAC

**HERMETIC LEAK RATE MOD CODES**

Designator	Required Leak Rate
<b>-585A</b>	1 x 10 <sup>-10</sup> cc Helium per second
<b>-585B</b>	1 x 10 <sup>-9</sup> cc Helium per second
<b>-585C</b>	1 x 10 <sup>-8</sup> cc Helium per second

**TABLE II: DIMENSIONS**

SYM	G	H	J
<b>01</b>	.062-.125 (1.57-3.18)	.469 MAX (11.91 MAX)	1.300 MAX (33.02 MAX)
<b>02</b>	.062-.250 (1.57-6.35)	.600 MAX (15.24 MAX)	1.425 MAX (36.20 MAX)
<b>03</b>	.062-.500 (1.57-12.7)	.850 MAX (21.59 MAX)	1.675 MAX (42.55 MAX)

### APPLICATION NOTES

- |   |   |
|---|---|
| <p>1. Material/finish:<br/>                 Shell, jam-nut, coupling nut – 300 Series CRES/see P/N development.<br/>                 Contacts, pin – Nickel-iron alloy/Gold plate.<br/>                 Contacts, socket – Copper alloy/Gold plate.<br/>                 Insulator, pin – Vitreous glass/N.A.<br/>                 Insulator, sockets – Hi-grade rigid dielectric/N.A.<br/>                 Grounding springs – Copper alloy/Gold plate.<br/>                 O-Rings and seals – Fluorosilicone blend/N.A.</p> | <p>2. Assembly identified with manufacturer's name and part number, space permitting.</p> <p>3. Test requirements:<br/>                 D.W.V. – Per Table IV<br/>                 I.R. – 5 GigOhms @ 500 VDC<br/>                 Hermeticity – &lt;1 x 10<sup>-7</sup> sccHe/sec @ 1 ATM differential.</p> <p>4. Metric dimensions (mm) are indicated in parentheses.</p> |
|---|---|

Dimensions in Inches (millimeters) are subject to change without notice.



## 237-280 Special Weld Mount Hermetic Receptacle MIL-DTL-38999 Series II Type (Similar to MS27478Y Series II)

B

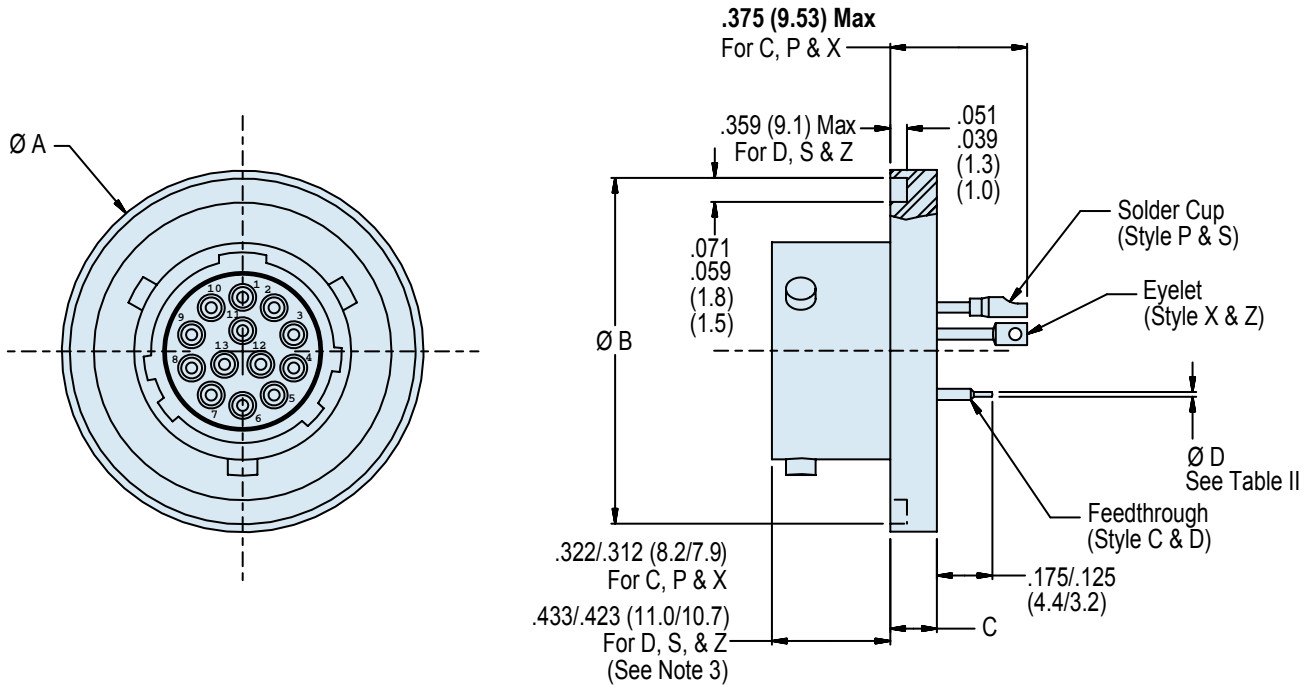
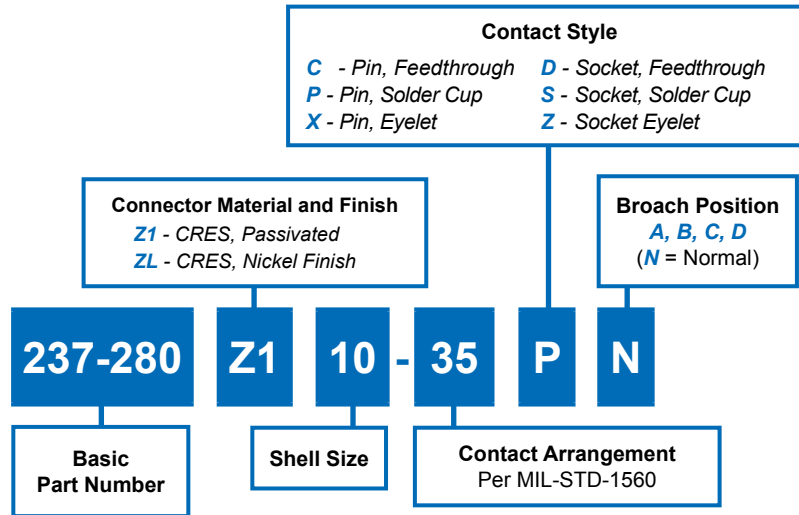

Dimensions in Inches (millimeters) are subject to change without notice.



**237-280**  
**Special Weld Mount Hermetic Receptacle**  
**MIL-DTL-38999 Series II Type (Similar to MS27478Y Series II)**

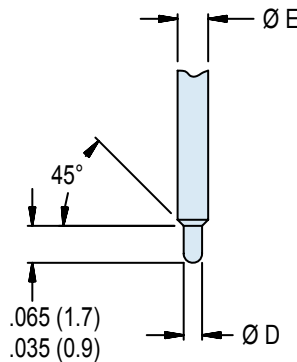

**TABLE I: Connector Dimensions**

Shell Size	A Dia	B Dia	C Flange
08	.863/.851 (21.9/21.6)	.820/.808 (20.8/20.5)	.134/.118 (3.4/3.0)
10	.984/.972 (25.0/24.7)	.941/.929 (23.9/23.6)	.134/.118 (3.4/3.0)
12	1.106/1.094 (28.1/27.8)	1.063/1.051 (27.0/26.7)	.134/.118 (3.4/3.0)
14	1.232/1.220 (31.3/31.0)	1.189/1.177 (30.2/29.9)	.134/.118 (3.4/3.0)
16	1.358/1.346 (34.5/34.2)	1.315/1.303 (33.4/33.1)	.134/.118 (3.4/3.0)
18	1.445/1.433 (37.7/36.4)	1.402/1.390 (35.6/35.3)	.134/.118 (3.4/3.0)
20	1.591/1.579 (40.4/40.1)	1.547/1.535 (39.3/39.0)	.134/.118 (3.4/3.0)
22	1.732/1.720 (44.0/43.7)	1.689/1.677 (42.9/42.6)	.165/.149 (4.2/3.8)
24	1.898/1.886 (48.2/47.9)	1.854/1.842 (47.1/46.8)	.165/.149 (4.2/3.8)

**TABLE II: Contact Size**

Contact Size	D Dia	E Dia
220	.011/.015 (0.28/0.38)	.0305/.0295 (0.77/0.75)
20	.024/.028 (0.61/0.71)	.041/.039 (1.04/0.99)
16	.0635/.0615 (1.61/1.56)	.0635/.0615 (1.61/1.56)
12	.095/.093 (2.41/2.36)	.095/.093 (2.41/2.36)
10	.126/.124 (3.20/3.15)	.126/.124 (3.20/3.15)



**For #22D and 20  
 Contacts Only  
 (#20 Inactive for New Design)**

**APPLICATION NOTES**

- |   |  |
|---|--|
| <p>1. Material/finish:<br/>                 Shell (Z1) – 304L CRES/passivate per ASTM A-697.<br/>                 Shell (ZL) – 304L CRES/nickel plate per DTL-38999.<br/>                 Contacts – 52 Ni-Alloy per AMS-I-23011 Class 2, MIL-DTL-45204 Type II, Class 1 (.00005 min thick).<br/>                 Insulator – full glass/N.A.<br/>                 Bayonets - 300 Series CRES/passivate.<br/>                 Seals – fluorosilicone blend elastomer/N.A.</p> | <p>2. Assembly identified with manufacturer's name and part number, space permitting.</p> <p>3. This area IAW MC27478 (MIL-DTL-38999, Series II).</p> <p>4. Performance Criteria IAW MIL-DTL-38999.</p> <p>5. Metric Dimensions (mm) in parentheses.</p> |
|---|--|

Dimensions in Inches (millimeters) are subject to change without notice.



**947-120**  
**Jam Nut Mount Hermetic Bulkhead Feed-Thru**  
 .062/.125<sup>in</sup> Panel  
 MIL-DTL-38999 Series II Type

**B**

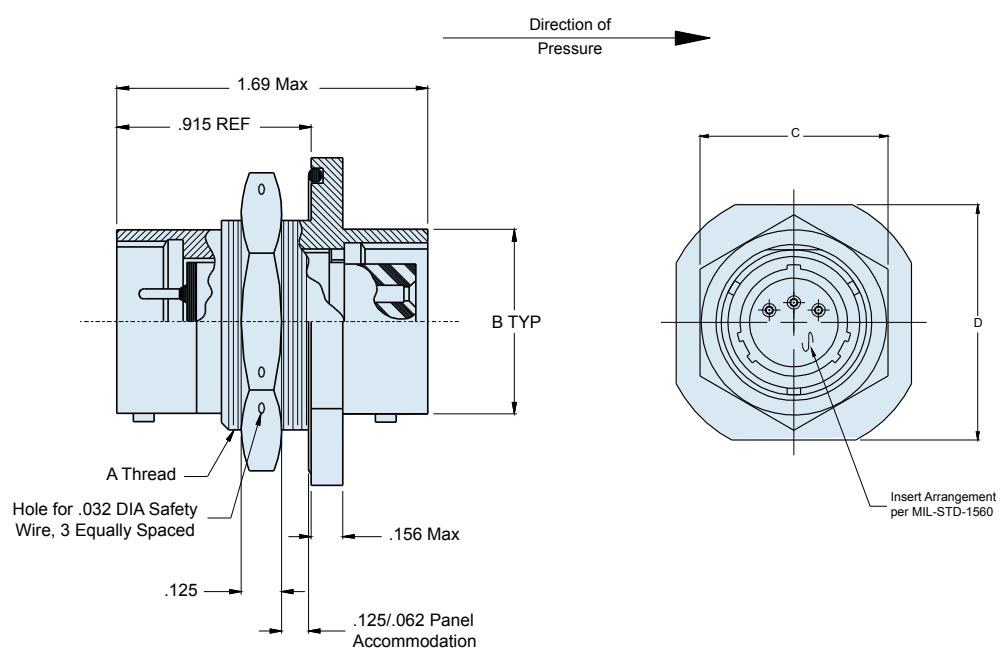
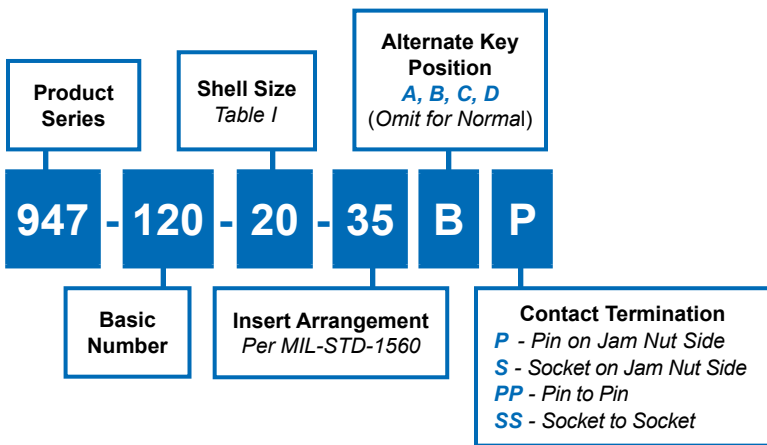

Dimensions in Inches (millimeters) are subject to change without notice.

**947-120**  
**Jam Nut Mount Hermetic Bulkhead Feed-Thru**  
 .062/.125<sup>in</sup> Panel  
 MIL-DTL-38999 Series II Type



TABLE I: CONNECTOR DIMENSIONS						
SHELL SIZE	A THREAD CLASS 2A	B DIA MAX	C HEX	D FLATS	E DIA ±.005(0.1)	F +.000-.005 (0-0.1)
08	.875-20 UNEF	.474(12.0)	1.062(27.0)	1.250(31.8)	.885(22.48)	.830(21.1)
10	1.000-20 UNEF	.591(15.0)	1.188(30.2)	1.375(34.9)	1.010(25.65)	.955(24.3)
12	1.125-18 UNEF	.751(19.1)	1.312(33.3)	1.500(38.1)	1.135(28.83)	1.085(27.6)
14	1.250-18 UNEF	.876(22.3)	1.438(36.5)	1.625(41.3)	1.260(32.01)	1.210(30.7)
16	1.375-18 UNEF	1.001(25.4)	1.562(39.7)	1.781(45.2)	1.385(35.18)	1.335(33.9)
18	1.500-18 UNEF	1.126(28.6)	1.688(42.9)	1.890(48.0)	1.510(38.35)	1.460(37.1)
20	1.625-18 UNEF	1.251(31.8)	1.812(46.0)	2.016(51.2)	1.635(41.53)	1.585(40.3)
22	1.750-18 UNS	1.376(35.0)	2.000(50.8)	2.140(54.4)	1.760(44.70)	1.710(43.4)
24	1.875-16 UN	1.501(38.1)	2.125(54.0)	2.265(57.5)	1.885(47.88)	1.835(46.6)

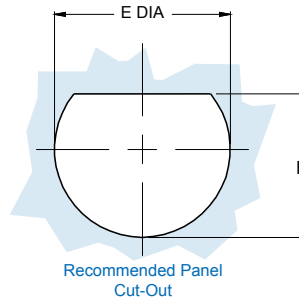

HERMETIC LEAK RATE MOD CODES	
Designator	Required Leak Rate
-585A	1 x 10 <sup>-10</sup> cc Helium per second
-585B	1 x 10 <sup>-9</sup> cc Helium per second
-585C	1 x 10 <sup>-8</sup> cc Helium per second

**APPLICATION NOTES**

- |   |   |
|---|---|
| <ol style="list-style-type: none"> <li>1. Assembly identified with manufacturer's name and part number, space permitting.</li> <li>2. For pin/pin or socket/socket, symmetrical layouts only consult factory for available insert arrangements).</li> <li>3. Power to a given contact on one end will result in power to contact directly opposite, regardless of identification letter.</li> <li>4. Hermeticity = less than 1 x 10<sup>-7</sup> cc/sec at one atmosphere.</li> </ol> | <ol style="list-style-type: none"> <li>5. Not for use in liquid atmosphere.</li> <li>6. Material/Finish:<br/>Shell, lock ring, jam nut, bayonet pins—stainless steel/passivate<br/>Contacts—copper alloy/gold plate and alloy 52/gold plate<br/>Insulators—high-grade rigid dielectric/N.A. and full glass<br/>Seals - silicone/ N.A.</li> <li>7. Metric Dimensions (mm) are indicated in parentheses.</li> </ol> |
|---|---|

Dimensions in Inches (millimeters) are subject to change without notice.



**947-278**  
**Jam Nut Mount Hermetic Bulkhead Feed-Thru**  
**MIL-DTL-38999 Series II Type (MS27477Y)**

**B**

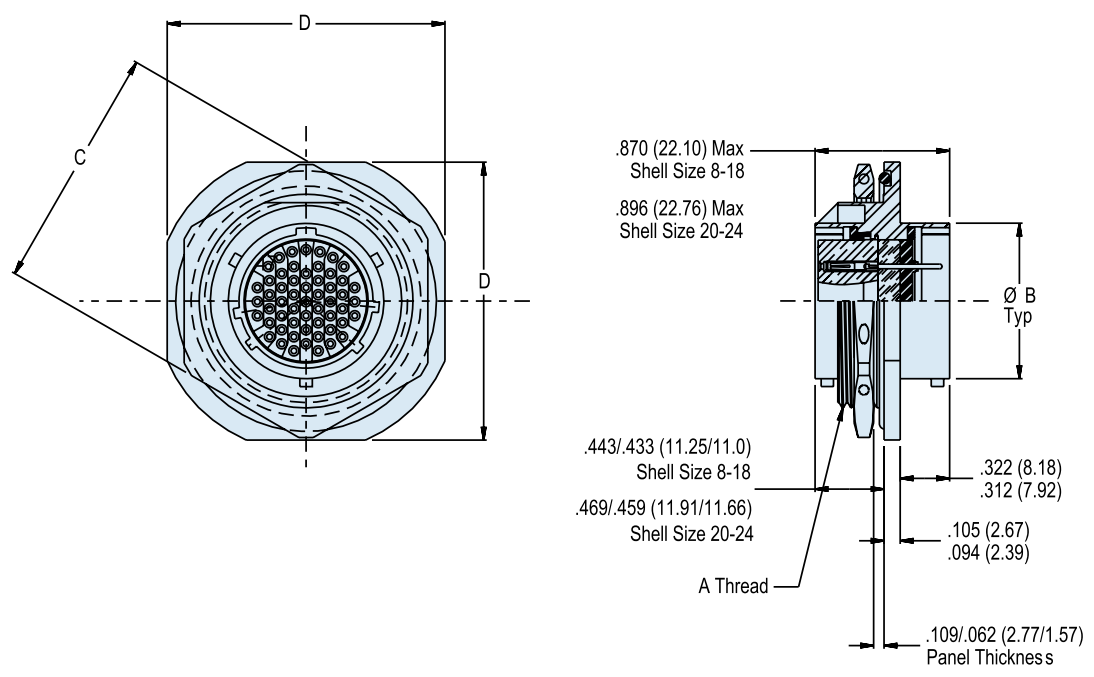
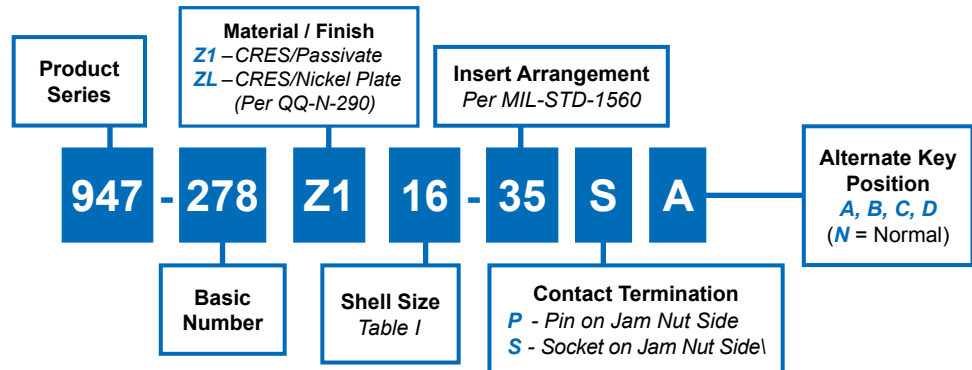

Dimensions in Inches (millimeters) are subject to change without notice.

947-278

Jam Nut Mount Hermetic Bulkhead Feed-Thru  
MIL-DTL-38999 Series II Type (MS27477Y)



MIL-DTL-38999 Type  
Hermetic Connectors

B

TABLE I: CONNECTOR DIMENSIONS

SHELL SIZE	A THREAD CLASS 2A	B DIA MAX	C HEX	D FLATS	E DIA ±.005(0.1)	F +.000-.005 (0-0.1)
08	11/16-24 UNEF	.474(12.0)	1.062(27.0)	1.250(31.8)	.890 (22.6)	.825 (21.0)
10	13/16-20 UNEF	.591(15.0)	1.188(30.2)	1.375(34.9)	1.015 (25.8)	.950 (24.1)
12	1-20 UNEF	.751(19.1)	1.312(33.3)	1.500(38.1)	1.140 (29.0)	1.080 (27.4)
14	1 1/8-18 UNEF	.876(22.3)	1.438(36.5)	1.625(41.3)	1.265 (32.1)	1.205 (30.6)
16	1 1/4-18 UNEF	1.001(25.4)	1.562(39.7)	1.781(45.2)	1.390 (35.3)	1.330 (33.8)
18	1 3/8-18 UNEF	1.126(28.6)	1.608(40.8)	1.890(48.0)	1.515 (38.5)	1.455 (37.0)
20	1 1/2-18 UNEF	1.251(31.8)	1.812(46.0)	2.016(51.2)	1.640 (41.7)	1.580 (40.1)
22	1 5/8-18 UNEF	1.376(35.0)	2.000(50.8)	2.140(54.4)	1.765 (44.8)	1.704 (43.3)
24	1 3/4-18 UNS	1.501(38.1)	2.125(54.0)	2.265(57.5)	1.890 (48.0)	1.830 (46.5)

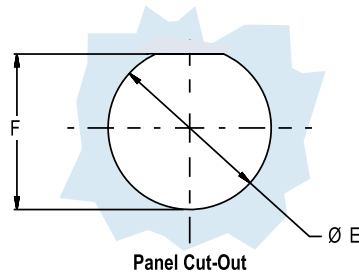

HERMETIC LEAK RATE MOD CODES

Designator	Required Leak Rate
-585A	1 x 10 <sup>-10</sup> cc Helium per second
-585B	1 x 10 <sup>-9</sup> cc Helium per second
-585C	1 x 10 <sup>-8</sup> cc Helium per second

APPLICATION NOTES

- Assembly identified with manufacturer's name and part number, space permitting.
- Glenair 947-278 will mate with any QPL manufacturer's plug having the same shell size, contact arrangement and opposite contact gender.
- Hermeticity = less than 1 x 10<sup>-7</sup> cc/sec at one atmosphere.
- Metric Dimensions (mm) are indicated in parentheses.
- Material/Finish:  
Shell and jam nut - CRES/passivate or CRES/Nickel plate  
Contacts, pin - nickel alloy/gold plate  
Contacts, socket - copper alloy/gold plate  
Bayonets - CRES/passivate  
Insulator, pins - full glass/N.A.  
Insulator - sockets - rigid dielectric/N.A.  
Seals - Fluorosilicone blend/N.A.

Dimensions in Inches (millimeters) are subject to change without notice.

© 2013 Glenair, Inc.

U.S. CAGE Code 06324

Printed in U.S.A.





# D38999/21 Box Mount Hermetic Receptacle MIL-DTL-38999 Series III

## How To Order: MS

**B**

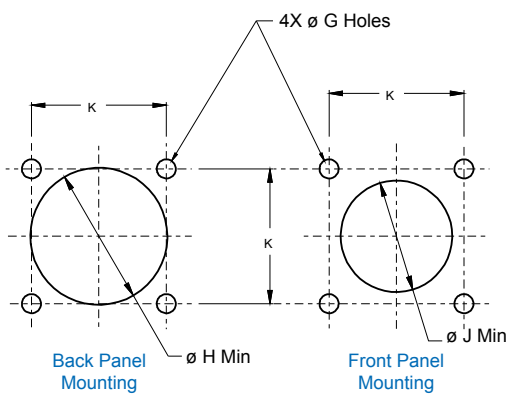
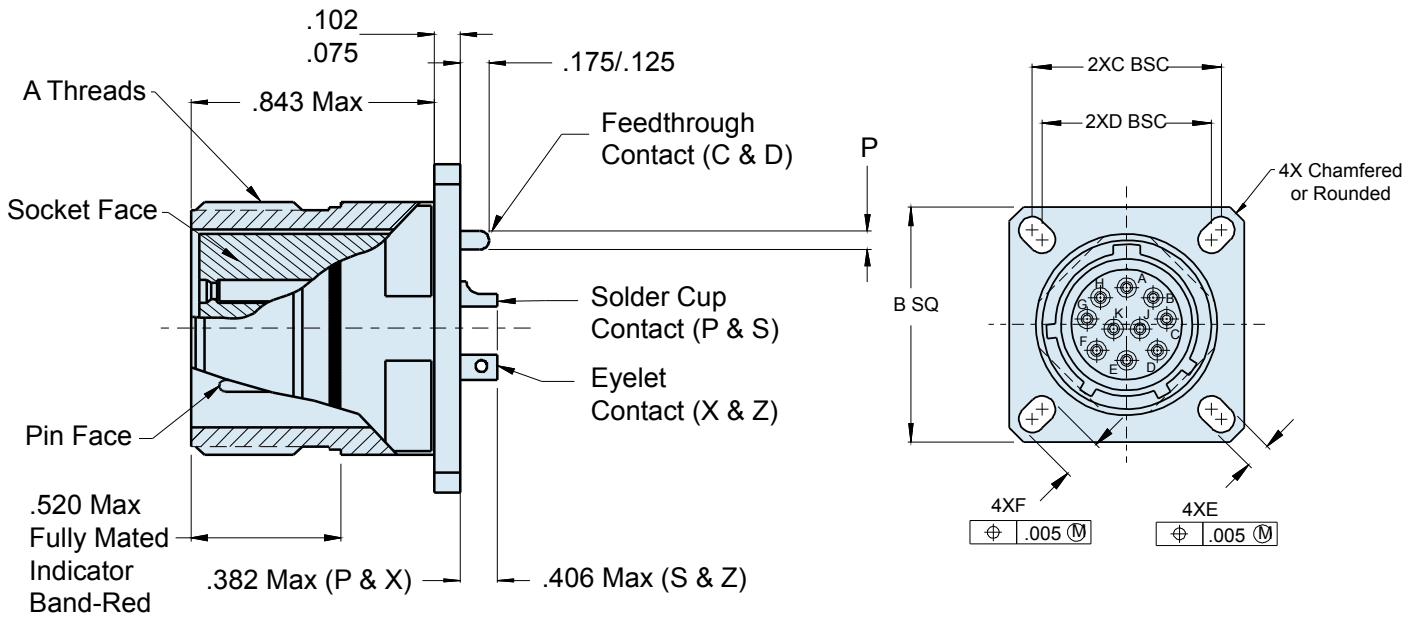
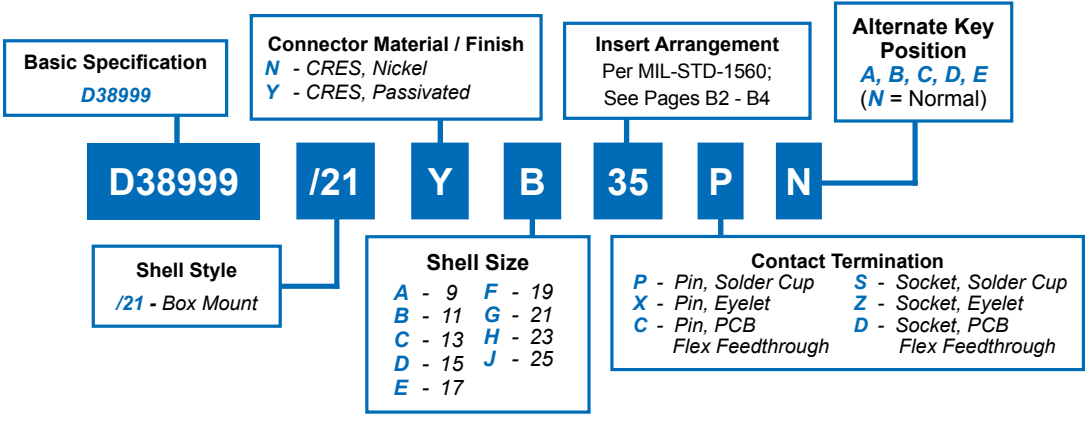

Dimensions in Inches (millimeters) are subject to change without notice.

# 233-100-H2 Box Mount Hermetic Receptacle MIL-DTL-38999 Series III Type



## How To Order: Commercial

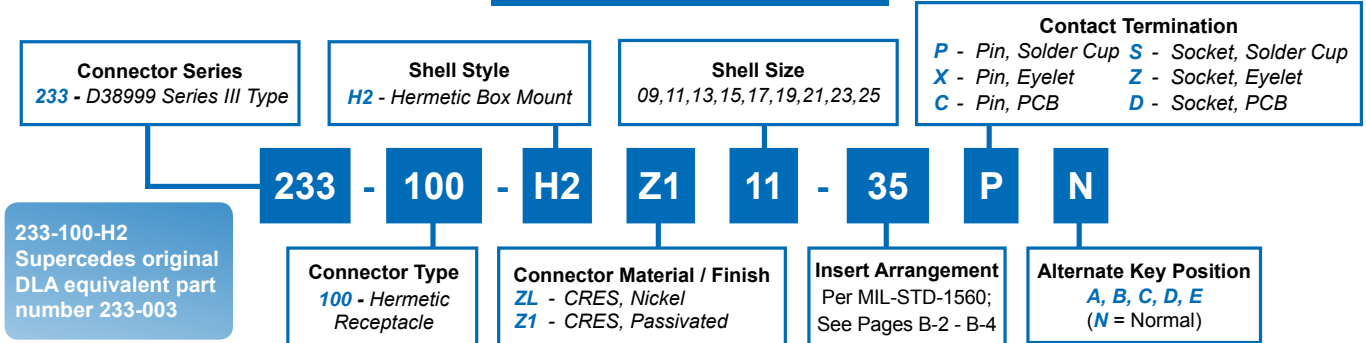

TABLE I: CONNECTOR DIMENSIONS

SHELL SIZE CODE	SHELL SIZE	A THREAD	B SQ ±.012(0.3)	C BSC	D BSC	E ±.008(0.2)	F ±.008(0.2)
A	9/09	.6250-.1P-.3L-TS-2A	.937(23.8)	.719(18.3)	.594(15.1)	.128(3.3)	.216(5.5)
B	11	.7500-.1P-.3L-TS-2A	1.031(26.2)	.812(20.6)	.719(18.3)	.128(3.3)	.194(4.9)
C	13	.8750-.1P-.3L-TS-2A	1.126(28.6)	.906(23.0)	.812(20.6)	.128(3.3)	.194(4.9)
D	15	1.0000-.1P-.3L-TS-2A	1.220(31.0)	.969(24.6)	.906(23.0)	.128(3.3)	.194(4.9)
E	17	1.1875-.1P-.3L-TS-2A	1.311(33.3)	1.062(27.0)	.969(24.6)	.128(3.3)	.194(4.9)
F	19	1.2500-.1P-.3L-TS-2A	1.437(36.5)	1.156(29.4)	1.062(27.0)	.128(3.3)	.194(4.9)
G	21	1.3750-.1P-.3L-TS-2A	1.563(39.7)	1.250(31.8)	1.156(29.4)	.128(3.3)	.194(4.9)
H	23	1.5000-.1P-.3L-TS-2A	1.689(42.9)	1.375(34.9)	1.250(31.8)	.154(3.9)	.242(6.1)
J	25	1.6250-.1P-.3L-TS-2A	1.811(46.0)	1.500(38.1)	1.375(34.9)	.154(3.9)	.242(6.1)

HERMETIC LEAK RATE MOD CODES	
Designator	Required Leak Rate
-585A	1 x 10 <sup>-10</sup> cc Helium per second
-585B	1 x 10 <sup>-9</sup> cc Helium per second
-585C	1 x 10 <sup>-8</sup> cc Helium per second

WIRE ACCOMODATION	
Contact Size	Wire Gauge
22D	#22 - #28
20	#20 - #24
16	#16 - #20
12	#12 - #14

TABLE II: CONTACT SIZE	
Contact Size	Ø P
22D	.011 (0.28) .015 (0.38)
20	.024 (0.61) .028 (0.71)
16	.0635 (1.61) .0615 (1.56)
12	.095 (2.41) .093 (2.36)

TABLE I (CONTINUED): CONNECTOR DIMENSIONS					
SHELL SIZE CODE	SHELL SIZE	Ø G HOLES ±.005(0.1)	Ø H MIN	Ø J MIN	K ±.005(0.1)
A	9/09	.128(3.3)	.656(16.7)	.516(13.1)	.719(18.3)
B	11	.128(3.3)	.781(19.8)	.625(15.9)	.812(20.6)
C	13	.128(3.3)	.921(23.4)	.750(19.1)	.906(23.0)
D	15	.128(3.3)	1.047(26.6)	.906(23.0)	.968(24.6)
E	17	.128(3.3)	1.218(30.9)	1.016(25.8)	1.062(27.0)
F	19	.128(3.3)	1.296(32.9)	1.142(35.9)	1.156(29.4)
G	21	.128(3.3)	1.421(36.1)	1.266(32.2)	1.250(31.8)
H	23	.154(3.9)	1.546(39.3)	1.375(34.9)	1.375(34.9)
J	25	.154(3.9)	1.672(42.5)	1.484(37.7)	1.500(38.1)

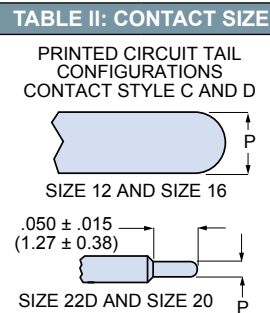

Dimensions in Inches (millimeters) are subject to change without notice.



# D38999/23 Jam Nut Mount Hermetic Receptacle MIL-DTL-38999 Series III

## How To Order: MS

**B**

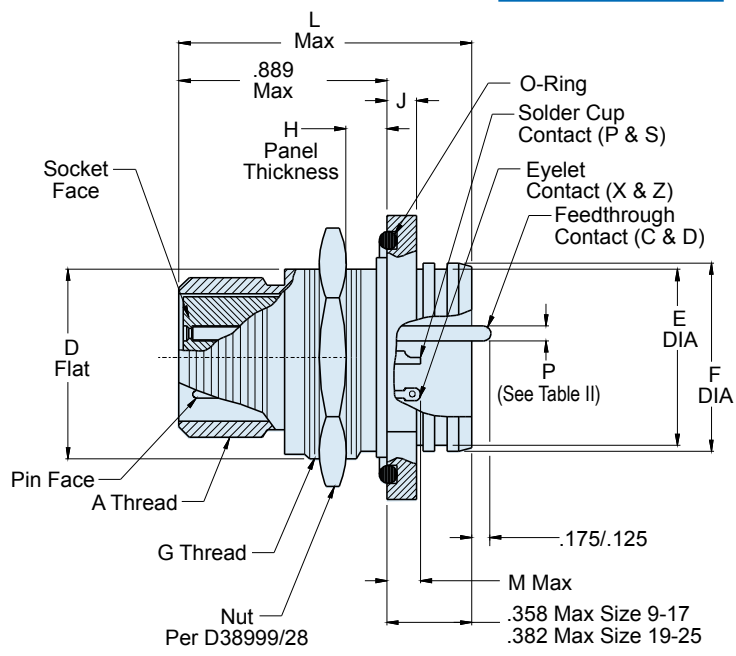
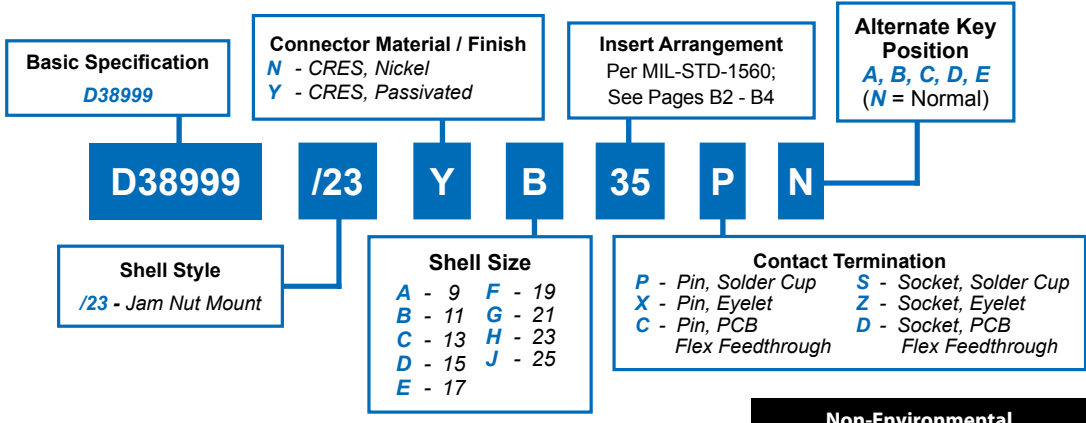

**Non-Environmental Rear Accessory Thread Adapter Available for this Receptacle See P/N 980-002 on Page B-90**

**TABLE II: CONTACT SIZE**

PRINTED CIRCUIT TAIL CONFIGURATIONS CONTACT STYLE C AND D

Contact Size	ø P
22D	.011 (0.28)
	.015 (0.38)
20	.024 (0.61)
	.028 (0.71)
16	.0635 (1.61)
	.0615 (1.56)
12	.095 (2.41)
	.093 (2.36)

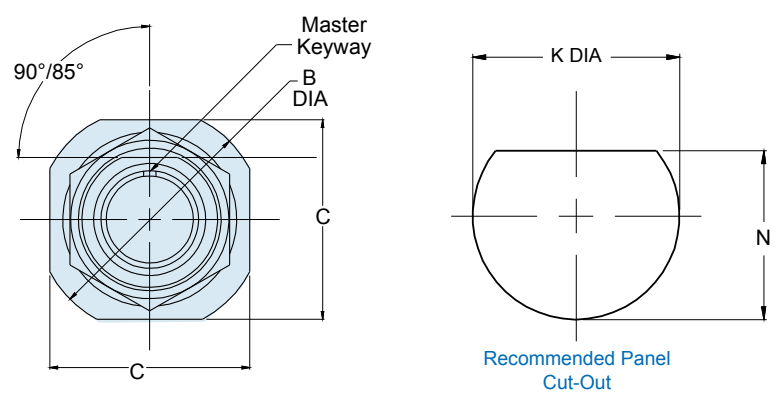

**WIRE ACCOMODATION**

Contact Size	Wire Guage
22D	#22 - #28
20	#20 - #24
16	#16 - #20
12	#12 - #14

Dimensions in Inches (millimeters) are subject to change without notice.

**233-100-H7**  
**Jam Nut Mount Hermetic Receptacle**  
**MIL-DTL-38999 Series III Type**



**How To Order: Commercial**

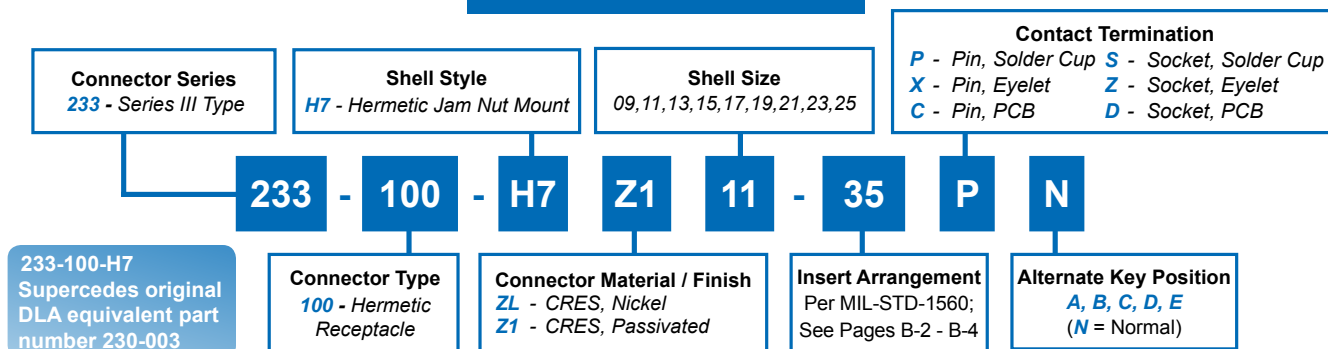

**B**

**TABLE I: CONNECTOR DIMENSIONS**

SHELL SIZE CODE	SHELL SIZE	A THREAD -0.1P-0.03L-TS	B DIA	C A/F ±.015(0.4)	D FLAT ±.005(0.1)	E DIA ±.012(0.3)	F DIA	G THREAD ISO METRIC	H ±.032(0.8)
A	9/09	0.625	1.201 (30.5) 1.177 (29.9)	1.063(27.0)	.650(16.5)	.602(15.3)	.653(16.6) .642(16.3)	M17 X 1.0-6g	.094(2.4)
B	11	0.750	1.386 (35.2) 1.362 (34.6)	1.252(31.8)	.750(19.1)	.724(18.4)	.775(19.7) .764(19.4)	M20 X 1.0-6g	.094(2.4)
C	13	0.875	1.512 (38.4) 1.488 (37.8)	1.374(34.9)	.937(23.8)	.850(21.6)	.905(23.0) .894(22.7)	M25 X 1.0-6g	.094(2.4)
D	15	1.000	1.638 (41.6) 1.614 (41.0)	1.500(38.1)	1.061(26.9)	.976(24.8)	1.031(26.2) 1.020(25.9)	M28 X 1.0-6g	.094(2.4)
E	17	1.187	1.764 (44.8) 1.740 (44.2)	1.626(41.3)	1.186(30.1)	1.102(28.0)	1.153(29.3) 1.142(29.0)	M32 X 1.0-6g	.094(2.4)
F	19	1.250	1.949 (49.5) 1.925 (48.9)	1.811(46.0)	1.311(33.3)	1.228(31.2)	1.278(32.5) 1.268(32.2)	M35 X 1.0-6g	.094(2.4)
G	21	1.375	2.075 (52.7) 2.050 (52.1)	1.937(49.2)	1.436(36.5)	1.350(34.3)	1.405(35.7) 1.394(35.4)	M38 X 1.0-6g	.094(2.4)
H	23	1.500	2.201 (55.9) 2.177 (55.3)	2.063(52.4)	1.561(39.6)	1.476(37.5)	1.531(38.9) 1.520(38.6)	M41 X 1.0-6g	.094(2.4)
J	25	1.625	2.323 (59.00) 2.299 (58.39)	2.189(55.6)	1.686(42.8)	1.602(40.7)	1.653(42.0) 1.642(41.7)	M44 X 1.0-6g	.094(2.4)

**TABLE I: (Continued) CONNECTOR DIMENSIONS**

J ±.008(0.2)	K DIA ±.005 (0.1)	L MAX	M MAX		N ±.005 (0.1)
			P&X	S&Z	
.106(2.7)	.693 (17.60)	1.150(29.2)	.209(5.3)	.232(5.9)	.658±.003 (16.71±.08)
.106(2.7)	.825 (20.96)	1.150(29.2)	.209(5.3)	.232(5.9)	.766 (19.46)
.106(2.7)	1.010 (25.65)	1.154(29.3)	.201(5.1)	.224(5.7)	.950 (24.13)
.106(2.7)	1.135 (28.83)	1.154(29.3)	.201(5.1)	.224(5.7)	1.080 (27.43)
.106(2.7)	1.260 (32.01)	1.154(29.3)	.201(5.1)	.224(5.7)	1.205 (30.61)
.138(3.5)	1.385 (35.18)	1.183(30.1)	.201(5.1)	.224(5.7)	1.330 (33.78)
.138(3.5)	1.510 (38.35)	1.183(30.1)	.201(5.1)	.224(5.7)	1.455 (36.96)
.138(3.5)	1.635 (41.53)	1.183(30.1)	.201(5.1)	.224(5.7)	1.580 (40.13)
.138(3.5)	1.760 (44.70)	1.183(30.1)	.201(5.1)	.224(5.7)	1.705 (43.31)

**HERMETIC LEAK RATE MOD CODES**

Designator	Required Leak Rate
-585A	1 x 10 <sup>-10</sup> cc Helium per second
-585B	1 x 10 <sup>-9</sup> cc Helium per second
-585C	1 x 10 <sup>-8</sup> cc Helium per second

Dimensions in Inches (millimeters) are subject to change without notice.



# D38999/25 Solder Mount Hermetic Receptacle MIL-DTL-38999 Series III

## How To Order: MS

**B**

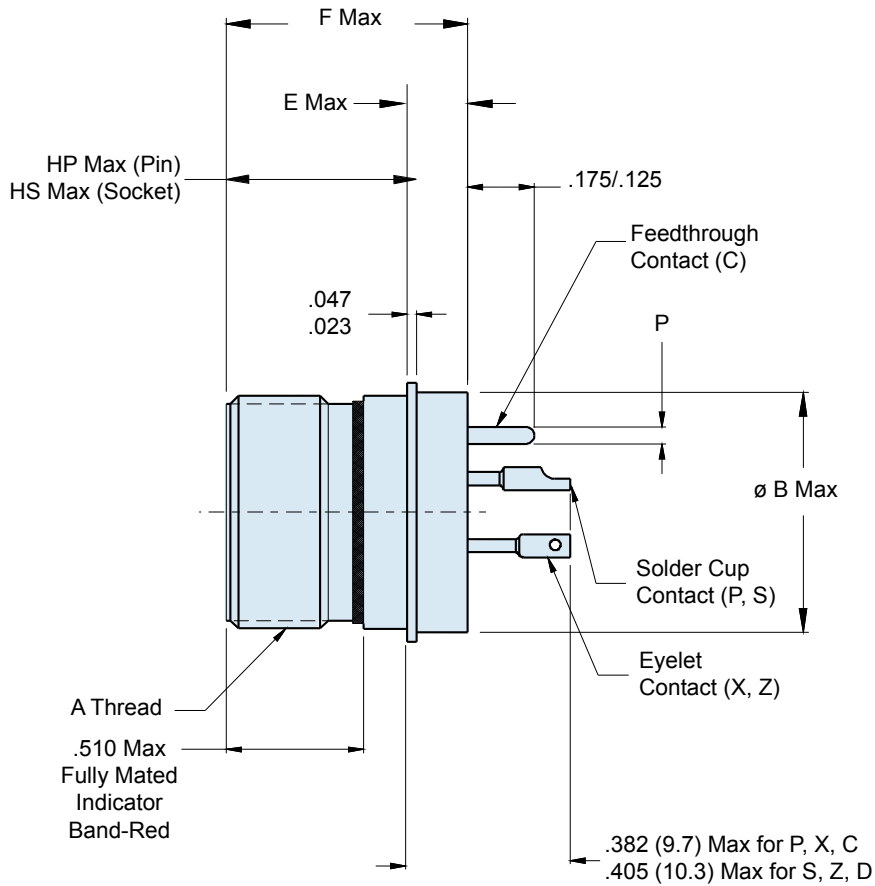
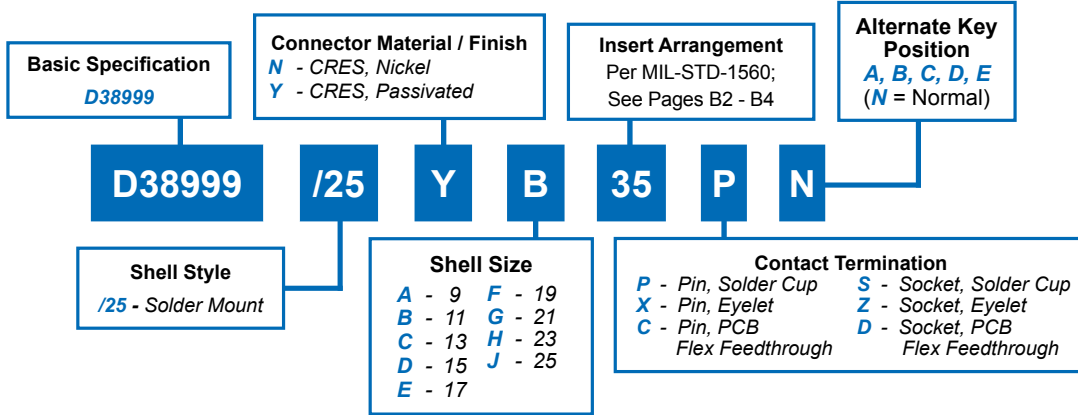

Dimensions in Inches (millimeters) are subject to change without notice.

# 233-100-H5 Solder Mount Hermetic Receptacle MIL-DTL-38999 Series III Type



## How To Order: Commercial

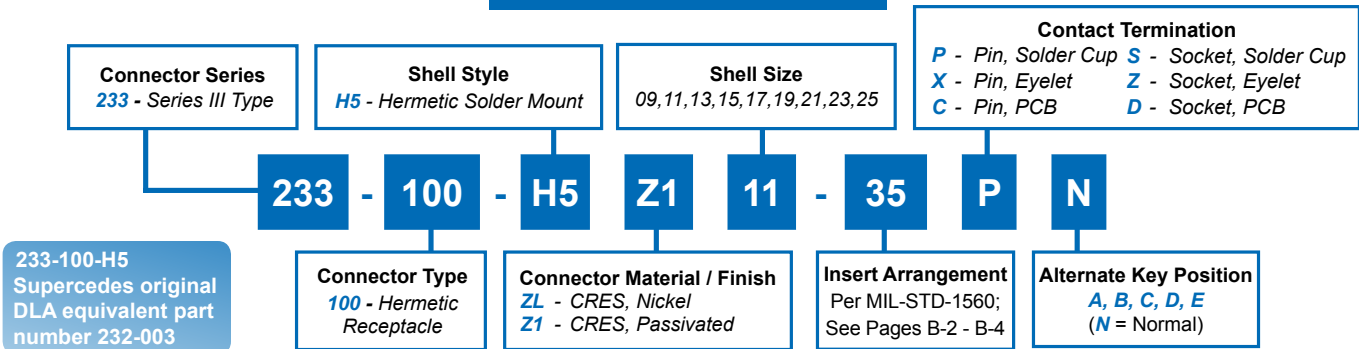

**TABLE I: CONNECTOR DIMENSIONS**

SHELL SIZE CODE	SHELL SIZE	A THREAD	ø B MAX	ø C MAX	ø D ±.005(0.1)	E MAX	F MAX	HP MAX	HS MAX
A	9/09	.6250-.1P-.3L-TS-2A	.673(17.1)	.764(19.4)	.680(17.3)	.201(5.1)	.937(23.8)	.677(17.2)	.764(19.4)
B	11	.7500-.1P-.3L-TS-2A	.783(19.9)	.858(21.8)	.789(20.0)	.201(5.1)	.937(23.8)	.677(17.2)	.764(19.4)
C	13	.8750-.1P-.3L-TS-2A	.909(23.1)	.980(24.9)	.914(23.2)	.201(5.1)	.937(23.8)	.677(17.2)	.764(19.4)
D	15	1.0000-.1P-.3L-TS-2A	1.031(26.2)	1.106(28.1)	1.038(26.4)	.201(5.1)	.937(23.8)	.677(17.2)	.764(19.4)
E	17	1.1875-.1P-.3L-TS-2A	1.157(29.4)	1.232(31.3)	1.164(29.6)	.201(5.1)	.937(23.8)	.677(17.2)	.764(19.4)
F	19	1.2500-.1P-.3L-TS-2A	1.252(31.8)	1.323(33.6)	1.258(32.0)	.201(5.1)	.937(23.8)	.677(17.2)	.764(19.4)
G	21	1.3750-.1P-.3L-TS-2A	1.378(35.0)	1.449(36.8)	1.383(35.1)	.201(5.1)	.937(23.8)	.677(17.2)	.764(19.4)
H	23	1.5000-.1P-.3L-TS-2A	1.504(38.2)	1.575(40.0)	1.508(38.3)	.232(5.9)	.969(24.6)	.677(17.2)	.764(19.4)
J	25	1.6250-.1P-.3L-TS-2A	1.626(41.3)	1.701(43.2)	1.643(41.7)	.232(5.9)	.969(24.6)	.677(17.2)	.764(19.4)

**TABLE II: CONTACT SIZE**

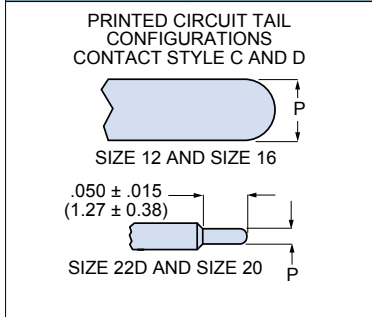

Contact Size	ø P
22D	.011 (0.28) .015 (0.38)
20	.024 (0.61) .028 (0.71)
16	.0635 (1.61) .0615 (1.56)
12	.095 (2.41) .093 (2.36)

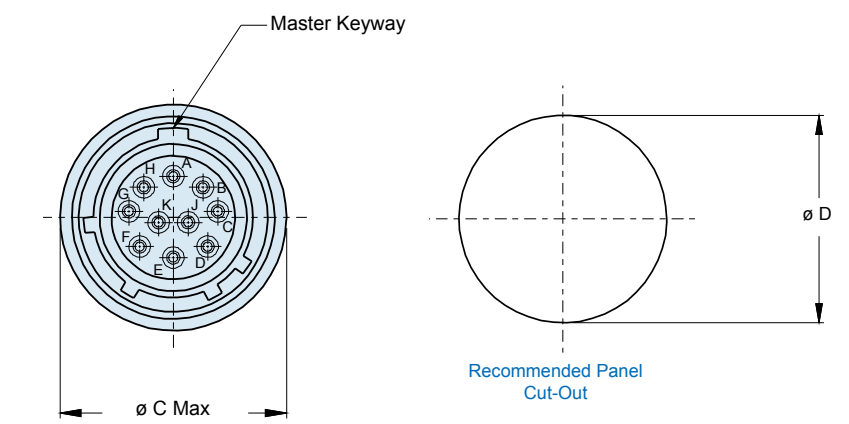

**WIRE ACCOMODATION**

Contact Size	Wire Gauge
22D	#22 - #28
20	#20 - #24
16	#16 - #20
12	#12 - #14

**HERMETIC LEAK RATE MOD CODES**

Designator	Required Leak Rate
-585A	1 x 10 <sup>-10</sup> cc Helium per second
-585B	1 x 10 <sup>-9</sup> cc Helium per second
-585C	1 x 10 <sup>-8</sup> cc Helium per second

Dimensions in Inches (millimeters) are subject to change without notice.





# D38999/27 Weld Mount Hermetic Receptacle MIL-DTL-38999 Series III

## How To Order: MS

**B**

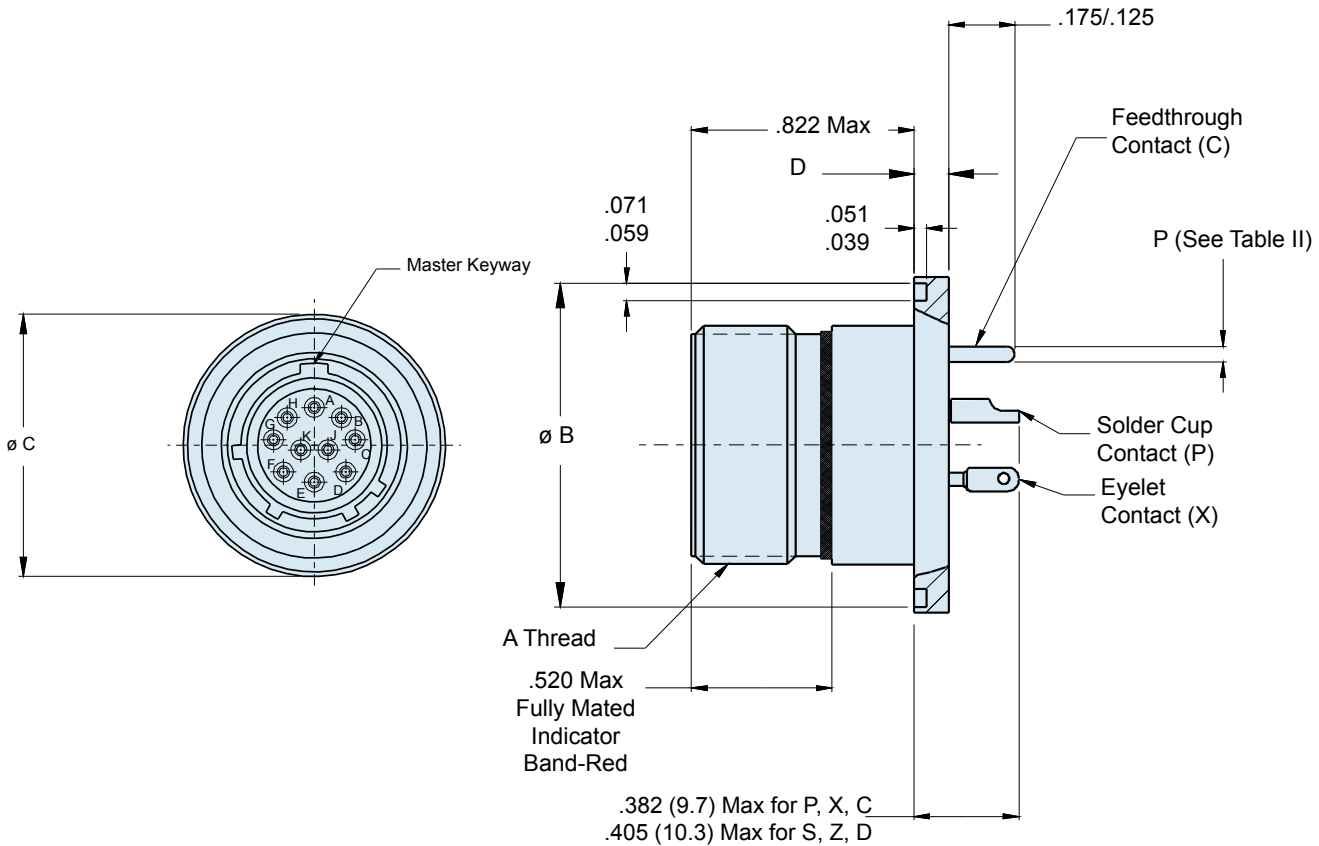
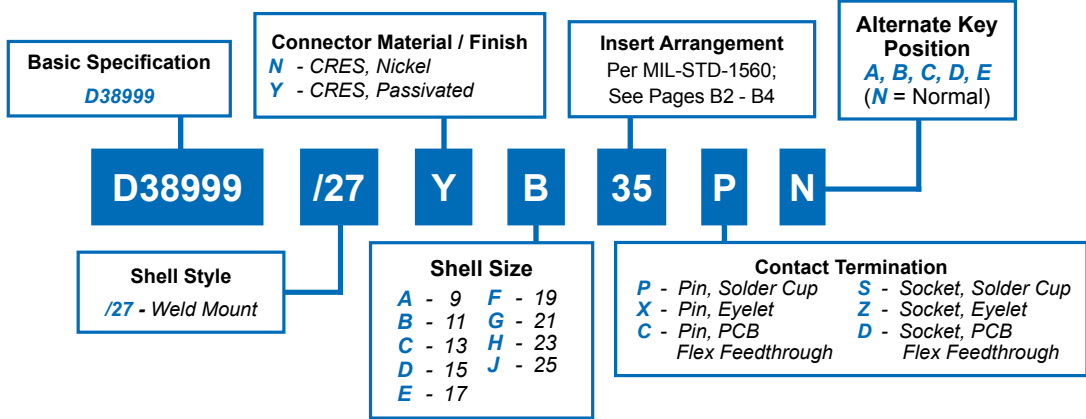

Consult Factory for Recommended Panel Cutout Dimensions

Dimensions in Inches (millimeters) are subject to change without notice.

# 233-100-H8

## Weld Mount Hermetic Receptacle

### MIL-DTL-38999 Series III Type



### How To Order: Commercial

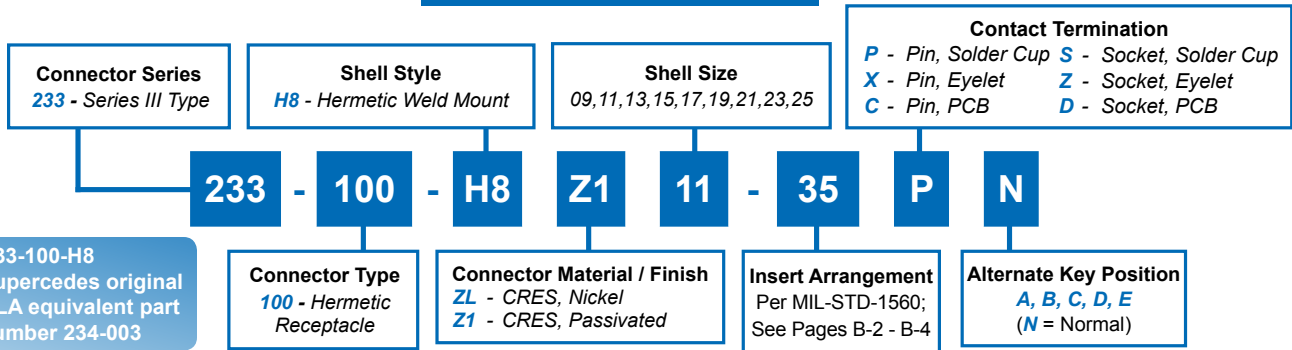

HERMETIC LEAK RATE MOD CODES	
Designator	Required Leak Rate
-585A	1 x 10 <sup>-10</sup> cc Helium per second
-585B	1 x 10 <sup>-9</sup> cc Helium per second
-585C	1 x 10 <sup>-8</sup> cc Helium per second

TABLE I: CONNECTOR DIMENSIONS					
SHELL SIZE CODE	SHELL SIZE	A THREAD	Ø B	Ø C	Ø D
A	9/09	.6250-.1P-.3L-TS-2A	.941 (23.9) .929 (23.6)	.984 (25.0) .972 (24.7)	.134 (3.4) .118 (3.0)
B	11	.7500-.1P-.3L-TS-2A	1.063 (27.0) 1.051 (27.0)	1.106 (28.1) 1.094 (27.8)	.134 (3.4) .118 (3.0)
C	13	.8750-.1P-.3L-TS-2A	1.189 (30.2) 1.177 (28.9)	1.232 (31.3) 1.220 (31.0)	.134 (3.4) .118 (3.0)
D	15	1.0000-.1P-.3L-TS-2A	1.315 (33.4) 1.303 (33.1)	1.358 (34.5) 1.346 (34.2)	.134 (3.4) .118 (3.0)
E	17	1.1875-.1P-.3L-TS-2A	1.402 (35.6) 1.390 (35.3)	1.445 (36.7) 1.433 (36.4)	.134 (3.4) .118 (3.0)
F	19	1.2500-.1P-.3L-TS-2A	1.547 (39.3) 1.535 (39.0)	1.591 (40.4) 1.579 (40.1)	.134 (3.4) .118 (3.0)
G	21	1.3750-.1P-.3L-TS-2A	1.689 (42.9) 1.677 (42.6)	1.732 (44.0) 1.720 (43.7)	.134 (3.4) .118 (3.0)
H	23	1.5000-.1P-.3L-TS-2A	1.854 (47.1) 1.842 (46.8)	1.898 (48.2) 1.886 (47.4)	.165 (4.2) .149 (3.8)
J	25	1.6250-.1P-.3L-TS-2A	1.941 (49.3) 1.929 (49.0)	1.984 (50.4) 1.972 (50.1)	.165 (4.2) .149 (3.8)

TABLE II: CONTACT SIZE	
Contact Size	Ø P
22D	.011 (0.28) .015 (0.38)
20	.024 (0.61) .028 (0.71)
16	.0635 (1.61) .0615 (1.56)
12	.095 (2.41) .093 (2.36)

WIRE ACCOMODATION	
Contact Size	Wire Gauge
22D	#22 - #28
20	#20 - #24
16	#16 - #20
12	#12 - #14

Dimensions in Inches (millimeters) are subject to change without notice.



# 233-103-H7 Jam Nut Mount Hermetic Bulkhead Feed-Thru MIL-DTL-38999 Series III Type

B

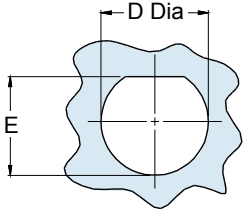
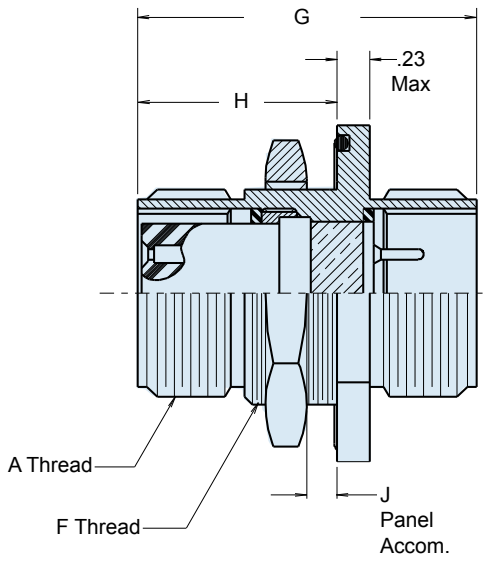
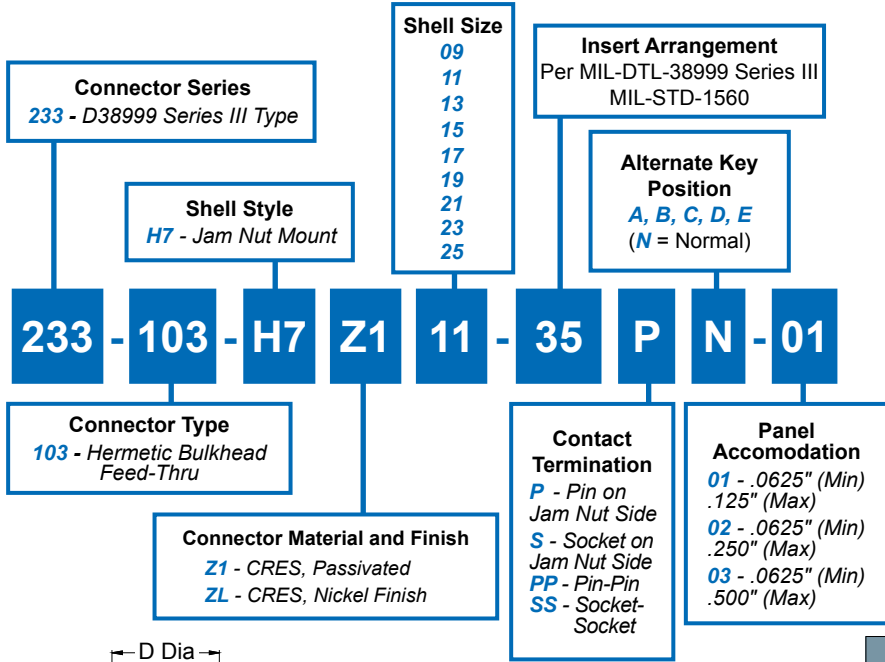

Recommended Panel Cut-Out

HERMETIC LEAK RATE MOD CODES	
Designator	Required Leak Rate
-585A	1 x 10 <sup>-10</sup> cc Helium per second
-585B	1 x 10 <sup>-9</sup> cc Helium per second
-585C	1 x 10 <sup>-8</sup> cc Helium per second

Panel Accomodation			
Sym	G Dim, OAL Max	H Dim, Max	J Dim, Panel
-01	1.670 (42.42)	.980 (24.89)	.125 (3.18) .062 (1.57)
-02	1.780 (45.21)	1.090 (27.69)	.250 (6.35) .062 (1.57)
-03	2.030 (51.56)	1.340 (34.04)	.500 (12.7) .062 (1.57)

TABLE II: CONNECTOR DIMENSIONS						
SHELL SIZE	A THREAD 0.1 P-0.3L-TS-2	B DIA	C	D DIA	E DIM	F THREAD METRIC
09	.6250	1.189 (30.20)	1.063 (27.00)	.703 (17.86) .693 (17.60)	.661 (16.79) .655 (16.64)	M17 x 1.0-6g
11	.7500	1.375 (34.93)	1.252 (31.80)	.835 (21.21) .825 (20.96)	.771 (19.58) .761 (19.33)	M20 x 1.0-6g
13	.8750	1.500 (38.10)	1.374 (34.90)	1.020 (25.91) 1.010 (25.65)	.955 (24.26) .945 (24.00)	M25 x 1.0-6g
15	1.0000	1.626 (41.30)	1.500 (38.10)	1.145 (29.03) 1.135 (28.83)	1.085 (27.56) 1.075 (27.30)	M28 x 1.0-6g
17	1.1875	1.752 (44.50)	1.626 (41.30)	1.270 (32.26) 1.260 (32.00)	1.210 (30.73) 1.200 (30.48)	M32 x 1.0-6g
19	1.2500	1.937 (49.20)	1.811 (46.00)	1.395 (35.43) 1.385 (35.18)	1.335 (33.91) 1.325 (33.65)	M35 x 1.0-6g
21	1.3750	2.063 (52.40)	1.937 (49.20)	1.520 (38.61) 1.510 (38.35)	1.460 (37.08) 1.450 (36.83)	M38 x 1.0-6g
23	1.5000	2.189 (55.60)	2.063 (52.40)	1.645 (41.78) 1.635 (41.53)	1.585 (40.26) 1.575 (40.00)	M41 x 1.0-6g
25	1.6250	2.311 (58.70)	2.189 (55.60)	1.770 (44.96) 1.760 (44.70)	1.710 (43.34) 1.700 (43.18)	M44 x 1.0-6g

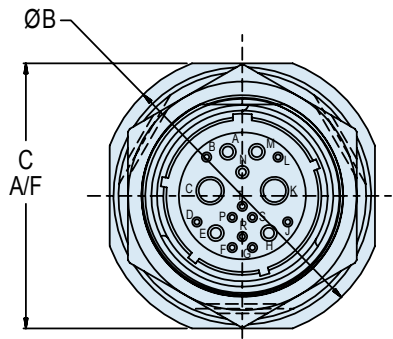

Insert Arrangement per MIL-DTL-38999 Series III MIL-STD-1560

APPLICATION NOTES	
1. Power to a given contact on one end will result in power to contact directly opposite, regardless of identification letter.	Contacts – Gold Plated. Pin: alloy 52; Skt.: copper alloy
2. Hermeticity = less than 1 x 10 <sup>-7</sup> cc/sec at one atmosphere. Not for use in liquid atmosphere.	Insulator, hermetic – fused vitreous glass/N.A.
3. Material/finish: Shell, nut – CRES/passivated or CRES/nickel per QQ-N-290.	Insulator, socket – rigid dielectric.
	Seals – fluorosilicone rubber/N.A.
	4. Metric dimensions (mm) are indicated in parentheses.

Dimensions in Inches (millimeters) are subject to change without notice.

**233-103-H9**  
**Jam Nut Mount Hermetic**  
**Plug/Receptacle Bulkhead Feed-Thru**  
**for MIL-DTL-38999 Series III Type**

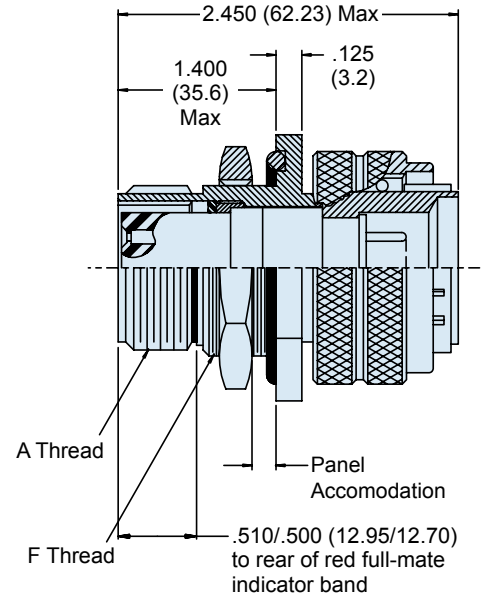
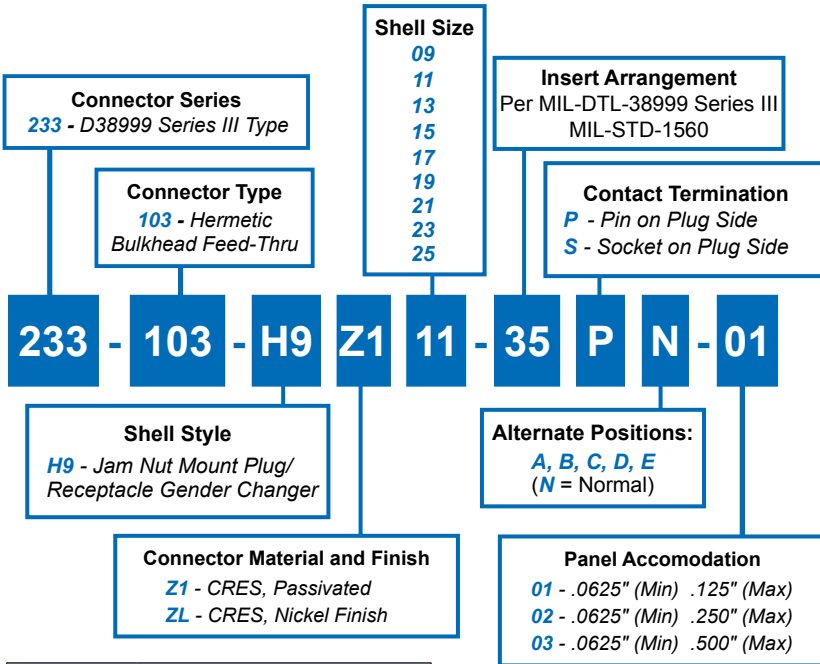

**HERMETIC LEAK RATE MOD CODES**

Designator	Required Leak Rate
-585A	1 x 10 <sup>-10</sup> cc Helium per second
-585B	1 x 10 <sup>-9</sup> cc Helium per second
-585C	1 x 10 <sup>-8</sup> cc Helium per second

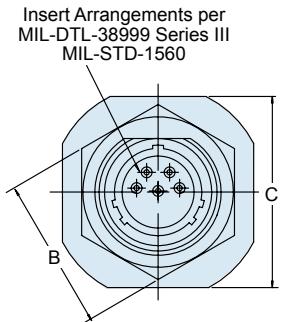

**TABLE I: CONNECTOR DIMENSIONS**

SHELL SIZE	A THREAD 0.1 P-0.3L-TS-2	B DIM MAX	C DIM MAX	D DIA ±.005 (.13)	E DIA	F THREAD x1-6g-0.100R
9	.6250	.945(24.0)	1.090(27.7)	.693 (17.60)	.661(16.79)/.655(16.64)	M17
11	.7500	1.063(27.0)	1.280(32.5)	.825 (20.96)	.771(19.58)/.761(19.33)	M20
13	.8750	1.260(32.0)	1.400(35.6)	1.010 (25.65)	.955(24.26)/.945(24.0)	M25
15	1.0000	1.417(36.0)	1.530(38.9)	1.135 (28.83)	1.085(27.56)/1.075(27.30)	M28
17	1.1875	1.457(37.0)	1.660(42.2)	1.260 (32.01)	1.210(30.73)/1.200(30.48)	M32
19	1.2500	1.614(41.0)	1.840(46.7)	1.385 (35.18)	1.335(33.91)/1.325(33.65)	M35
21	1.3750	1.811(46.0)	1.970(50.5)	1.510 (38.35)	1.460(37.08)/1.450(36.83)	M38
23	1.5000	1.968(50.0)	2.090(53.1)	1.635 (41.53)	1.585(40.26)/1.575(40.00)	M41
25	1.6250	2.017(51.2)	2.210(56.1)	1.760 (44.70)	1.710(43.43)/1.700(43.18)	M44

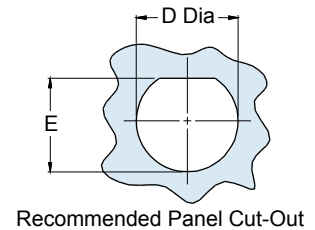

**APPLICATION NOTES**

1. Power to a given contact on one end will result in power to contact directly opposite, regardless of identification letter.	QQ-N-290. Contacts – Gold Plated. Pin: alloy 52; Skt.: copper alloy
2. Hermeticity is less than 1 x 10 <sup>-7</sup> cc/sec at one atmosphere. Not for use in liquid atmosphere.	Insulator – fused vitreous glass/N.A. Seals – fluorosilicone rubber/N.A.
3. Material/finish: Shell, nut – CRES/passivated, carbon steel/fused tin or CRES/nickel per	4. Metric dimensions (mm) are indicated in parentheses.

Dimensions in Inches (millimeters) are subject to change without notice.



237-033

**Jam Nut Mount Hermetic with Double O-Rings  
Plug/Receptacle Bulkhead Feedthrough  
for MIL-DTL-38999 Series III Type**

B

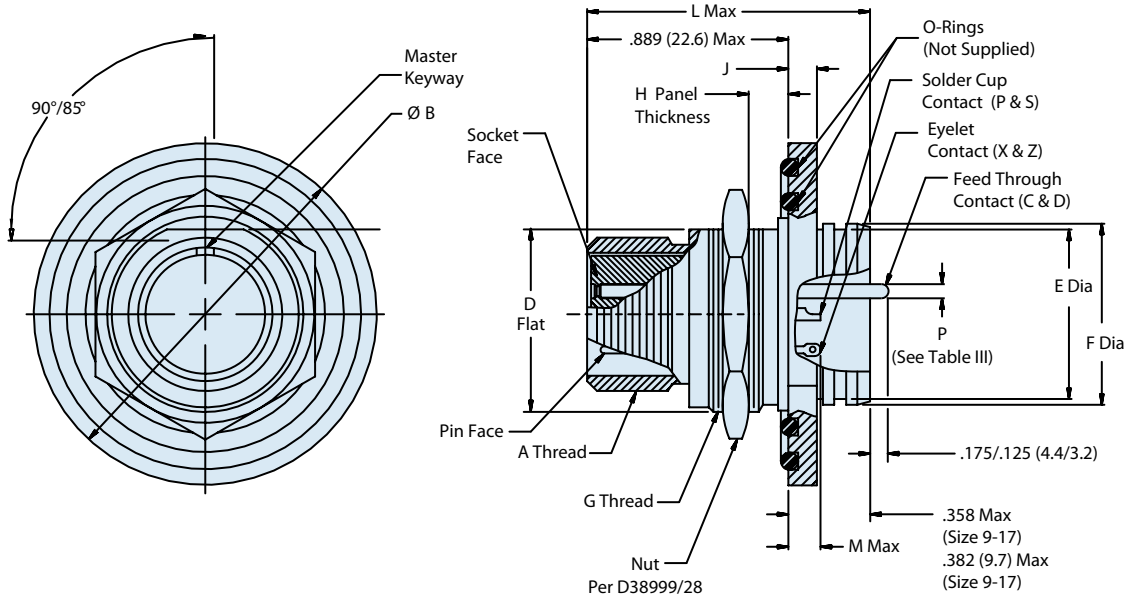
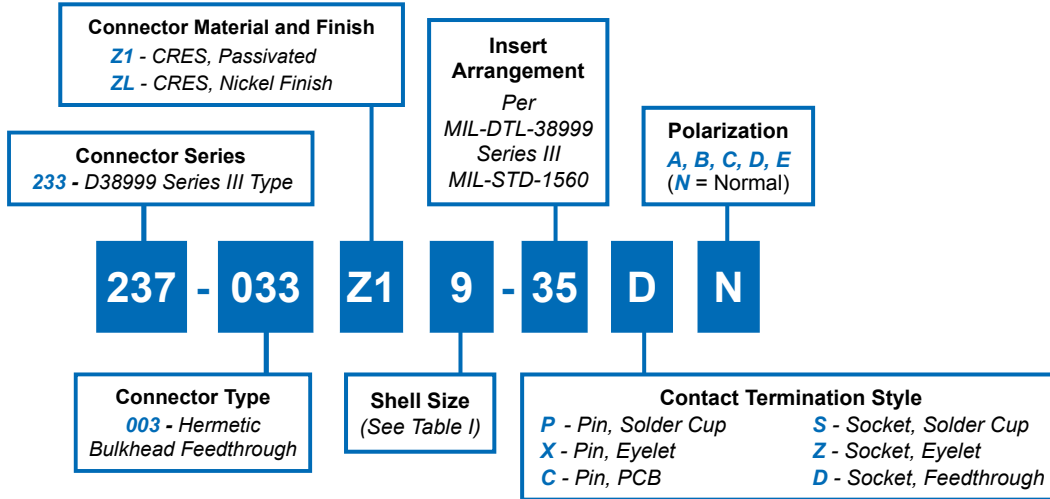

Dimensions in Inches (millimeters) are subject to change without notice.

237-033

# Jam Nut Mount Hermetic with Double O-Rings Plug/Receptacle Bulkhead Feedthrough for MIL-DTL-38999 Series III Type

MIL-DTL-38999 Type  
Hermetic Connectors

B

TABLE I: Shell Size, Thread and Connector Dimensions (Continued Below)

Shell Size Code	Shell Size	A Thread -0.1P-0.03L-TS	B Dia	D Flat	E Dia	F Dia	G Thread ISO Metric x 1.0-6g
A	9	.6250	1.270/1.260 (32.26/32.00)	.654/.645 (16.61/16.38)	.614/.591 (15.60/15.01)	.653/.642 (16.59/16.31)	M17
B	11	.7500	1.385/1.375 (35.18/34.93)	.754/.745 (19.15/18.92)	.736/.713 (18.69/18.11)	.775/.764 (19.69/19.41)	M20
C	13	.8750	1.585/1.575 (40.26/40.01)	.941/.932 (23.90/23.67)	.862/.839 (21.89/21.31)	.905/.894 (22.99/22.71)	M25
D	15	1.0000	1.700/1.690 (43.18/42.93)	1.065/1.056 (27.05/26.82)	.988/.965 (25.10/24.51)	1.031/1.020 (26.19/25.91)	M28
E	17	1.1875	1.860/1.850 (47.24/46.99)	1.190/1.181 (30.23/30.00)	1.114/1.091 (28.30/27.71)	1.153/1.142 (29.29/29.01)	M32 (See Note 2)
F	19	1.2500	1.975/1.965 (50.17/49.91)	1.315/1.306 (33.40/33.17)	1.240/1.217 (31.50/30.91)	1.278/1.268 (32.46/32.21)	M35
G	21	1.3750	2.095/2.085 (53.21/52.96)	1.440/1.431 (36.58/36.35)	1.362/1.339 (34.59/34.01)	1.405/1.394 (35.69/35.41)	M38
H	23	1.5000	2.213/2.203 (56.21/55.96)	1.565/1.556 (39.75/39.52)	1.488/1.465 (37.80/37.21)	1.531/1.520 (38.89/38.61)	M41
J	25	1.6250	2.325/2.315 (59.06/58.80)	1.690/1.681 (42.93/42.70)	1.614/1.591 (41.0/40.41)	1.653/1.642 (41.99/41.71)	M44

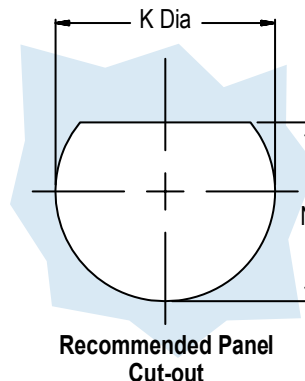

TABLE I: (Continued from Above)

Shell Size Code	Shell Size	H	J	K Dia	L Max	M Max		N
						P and X	S and Z	
A	9	.125/.062 (3.18/1.57)	.114/.098 (2.90/2.49)	.703 (17.86) .693 (17.60)	1.149 (29.18)	.208 (5.28)	.232 (5.89)	.661 (16.79) .655 (16.64)
B	11	.125/.062 (3.18/1.57)	.114/.098 (2.90/2.49)	.835 (21.21) .825 (20.96)	1.149 (29.18)	.208 (5.28)	.232 (5.89)	.771 (19.58) .761 (19.33)
C	13	.125/.062 (3.18/1.57)	.114/.098 (2.90/2.49)	1.020 (25.91) 1.010 (25.65)	1.153 (29.29)	.200 (5.08)	.224 (5.69)	.955 (24.26) .945 (24.00)
D	15	.125/.062 (3.18/1.57)	.114/.098 (2.90/2.49)	1.145 (29.08) 1.135 (28.83)	1.153 (29.29)	.200 (5.08)	.224 (5.69)	1.085 (27.56) 1.075 (27.30)
E	17	.125/.062 (3.18/1.57)	.114/.098 (2.90/2.49)	1.270 (32.26) 1.260 (32.00)	1.153 (29.29)	.200 (5.08)	.224 (5.69)	1.210 (30.73) 1.2200 (30.99)
F	19	.125/.062 (3.18/1.57)	.146/.130 (3.71/3.30)	1.395 (35.43) 1.385 (35.18)	1.185 (30.10)	.200 (5.08)	.224 (5.69)	1.335 (33.91) 1.325 (33.65)
G	21	.125/.062 (3.18/1.57)	.146/.130 (3.71/3.30)	1.520 (38.61) 1.510 (38.35)	1.185 (30.10)	.200 (5.08)	.224 (5.69)	1.460 (37.08) 1.450 (36.83)
H	23	.125/.062 (3.18/1.57)	.146/.130 (3.71/3.30)	1.645 (41.78) 1.635 (41.53)	1.185 (30.10)	.200 (5.08)	.224 (5.69)	1.585 (40.26) 1.575 (40.00)
J	25	.125/.062 (3.18/1.57)	.146/.130 (3.71/3.30)	1.770 (44.96) 1.760 (44.70)	1.185 (30.10)	.200 (5.08)	.224 (5.69)	1.710 (43.43) 1.700 (43.18)

TABLE III:  
Contact Size  
and Diameter

Contact Size	Ø P
22D	.011/.015 (0.28/0.38)
20	.024/.028 (0.61/0.71)
16	.0635/.0615 (1.61/1.56)
12	.095/.093 (2.41/2.36)
10	.126/.124 (3.20/3.15)

## APPLICATION NOTES

- Assembly identified with manufacturer's name and P/N, space permitting.
- Modified major diameter 31.95-31.80 (1.257-1.252).
- Glenair 237-033 receptacle connector is designed to mate with and QPL manufacturer's MIL-DTL-38999 Series III plug connector having the same insert arrangement and polarization.
- Glenair 237-033 same as D38999/23 except double O-Ring configuration.
- Material/finish:  
Shell, nut – CRES/passivated or CRES/nickel per QQ-N-290.  
Contacts – Nickel iron alloy 52/gold.  
Insulator – fused vitreous glass/N.A.  
Seals – fluorosilicone rubber/N.A.
- Metric dimensions (mm) are indicated in parentheses.

Dimensions in Inches (millimeters) are subject to change without notice.

© 2013 Glenair, Inc.

U.S. CAGE Code 06324

Printed in U.S.A.

GLENAIR, INC. • 1211 AIR WAY • GLENDALE, CA 91201-2497 • 818-247-6000 • FAX 818-500-9912  
www.glenair.com B-59 E-Mail: sales@glenair.com





**237-063**  
Special Hermetic Jam Nut Mount Receptacle  
Bulkhead Feed-Thru with P.C. Tail Contacts  
for MIL-DTL-38999 Series III Type

**B**

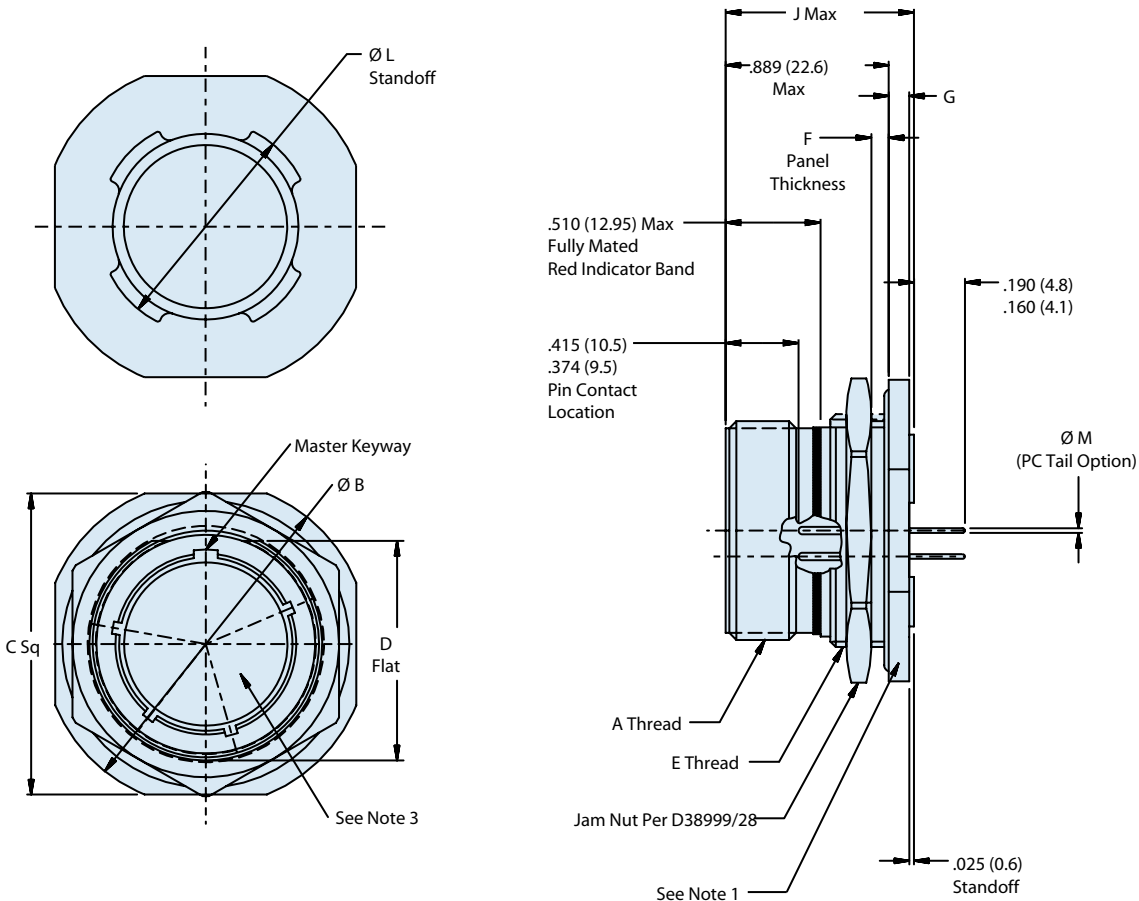
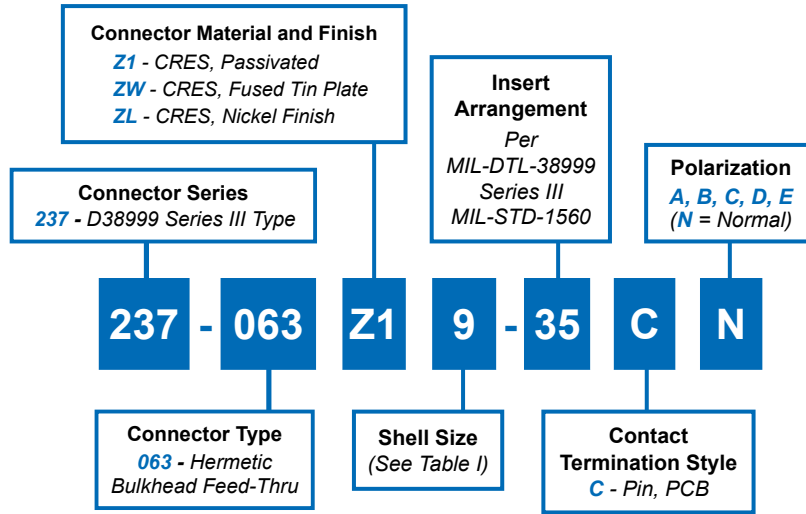

Dimensions in Inches (millimeters) are subject to change without notice.

237-063

## Special Hermetic Jam Nut Mount Receptacle Bulkhead Feed-Thru with P.C. Tail Contacts for MIL-DTL-38999 Series III Type

MIL-DTL-38999 Type  
Hermetic Connectors

B

TABLE I: Shell Size, Thread  
and Connector Dimensions (Continued Below)

Shell Size Code	Shell Size	A Thread -0.1P-0.03L-TS	B Dia	C A/F	D Flat	E Thread ISO Metric x 1.0-6g
A	9	.6250	1.200/1.178 (30.48/29.92)	1.078/1.048 (27.38/26.62)	.654/.645 (16.61/16.38)	M17
B	11	.7500	1.385/1.363 (35.18/34.62)	1.267/1.237 (32.18/31.42)	.754/.745 (19.15/18.92)	M20
C	13	.8750	1.511/1.489 (38.38/37.82)	1.389/1.359 (35.28/34.52)	.941/.932 (23.90/23.67)	M25
D	15	1.0000	1.637/1.615 (41.58/41.02)	1.515/1.485 (38.48/37.72)	1.065/1.056 (27.05/26.82)	M28
E	17	1.1875	1.763/1.741 (44.78/44.22)	1.641/1.611 (41.68/40.92)	1.190/1.181 (30.23/30.00)	M32 (See Note 2)
F	19	1.2500	1.948/1.926 (49.48/48.92)	1.826/1.796 (46.38/45.62)	1.315/1.306 (33.40/33.17)	M35
G	21	1.3750	2.074/2.051 (52.68/52.10)	1.952/1.922 (49.58/48.82)	1.440/1.431 (36.58/36.35)	M38
H	23	1.5000	2.200/2.177 (55.88/55.30)	2.078/2.048 (52.78/52.02)	1.565/1.556 (39.75/39.52)	M41
J	25	1.6250	2.322/2.300 (58.98/58.42)	2.204/2.174 (55.98/55.22)	1.690/1.681 (42.93/42.70)	M44

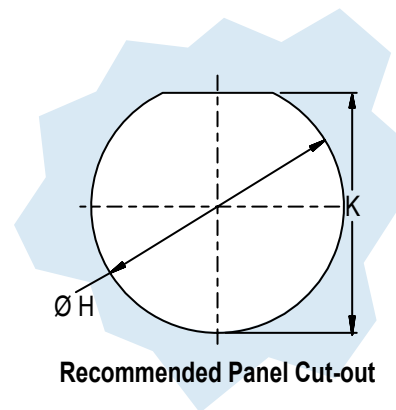

TABLE I: (Continued from Above)

Shell Size Code	Shell Size	F	G	H Dia	J Max	K	L Dia
A	9	.125/.062 (3.18/1.57)	.113/.108 (2.87/2.74)	.703 (17.86) .693 (17.60)	1.149 (29.18)	.661 (16.79) .655 (16.64)	.653/.642 (16.59/16.31)
B	11	.125/.062 (3.18/1.57)	.113/.108 (2.87/2.74)	.835 (21.21) .825 (20.96)	1.149 (29.18)	.771 (19.58) .761 (19.33)	.775/.764 (19.69/19.41)
C	13	.125/.062 (3.18/1.57)	.113/.108 (2.87/2.74)	1.020 (25.91) 1.010 (25.65)	1.153 (29.29)	.955 (24.26) .945 (24.00)	.905/.894 (22.99/22.71)
D	15	.125/.062 (3.18/1.57)	.113/.108 (2.87/2.74)	1.145 (29.08) 1.135 (28.83)	1.153 (29.29)	1.085 (27.56) 1.075 (27.30)	1.031/1.020 (26.19/25.91)
E	17	.125/.062 (3.18/1.57)	.113/.108 (2.87/2.74)	1.270 (32.26) 1.260 (32.00)	1.153 (29.29)	1.210 (30.73) 1.200 (30.48)	1.153/1.142 (29.29/29.01)
F	19	.125/.062 (3.18/1.57)	.145/.133 (3.68/3.38)	1.395 (35.43) 1.385 (35.18)	1.185 (30.10)	1.335 (33.91) 1.325 (33.65)	1.279/1.268 (32.49/32.21)
G	21	.125/.062 (3.18/1.57)	.145/.133 (3.68/3.38)	1.520 (38.61) 1.510 (38.35)	1.185 (30.10)	1.460 (37.08) 1.450 (36.83)	1.405/1.394 (35.69/35.41)
H	23	.125/.062 (3.18/1.57)	.145/.133 (3.68/3.38)	1.645 (41.78) 1.635 (41.53)	1.185 (30.10)	1.585 (40.26) 1.575 (40.00)	1.531/1.520 (38.89/38.61)
J	25	.125/.062 (3.18/1.57)	.145/.133 (3.68/3.38)	1.770 (44.96) 1.760 (44.70)	1.185 (30.10)	1.710 (43.43) 1.700 (43.18)	1.653/1.642 (41.99/41.71)

TABLE III:  
Contact Size  
and Diameter

Contact Size	Ø P
22	.022/.018 (0.56/0.46)
20	.027/.023 (0.69/0.58)
16	.042/.038 (1.07/0.97)
12	.052/.048 (1.32/1.22)

### APPLICATION NOTES

- Assembly identified with manufacturer's name and P/N, space permitting.
- Modified major diameter 31.95-31.80 (1.257-1.252).
- Insert arrangements in accordance with MIL-STD-1560.
- Metric dimensions (mm) are indicated in parentheses.
- Material/finish:  
Shell, jam nut – CRES/passivated or CRES/nickel per QQ-N-290.  
Contacts – Nickel iron alloy 52/gold plated.  
Insulator – fused vitreous glass/N.A.  
Seals – fluorosilicone rubber/N.A.

Dimensions in Inches (millimeters) are subject to change without notice.

© 2013 Glenair, Inc.

U.S. CAGE Code 06324

Printed in U.S.A.

GLENAIR, INC. • 1211 AIR WAY • GLENDALE, CA 91201-2497 • 818-247-6000 • FAX 818-500-9912  
www.glenair.com B-61 E-Mail: sales@glenair.com



# 237-153 Hermetic Dual Flange Jam Nut Mount Receptacle for MIL-DTL-38999 Series III Type

**B**

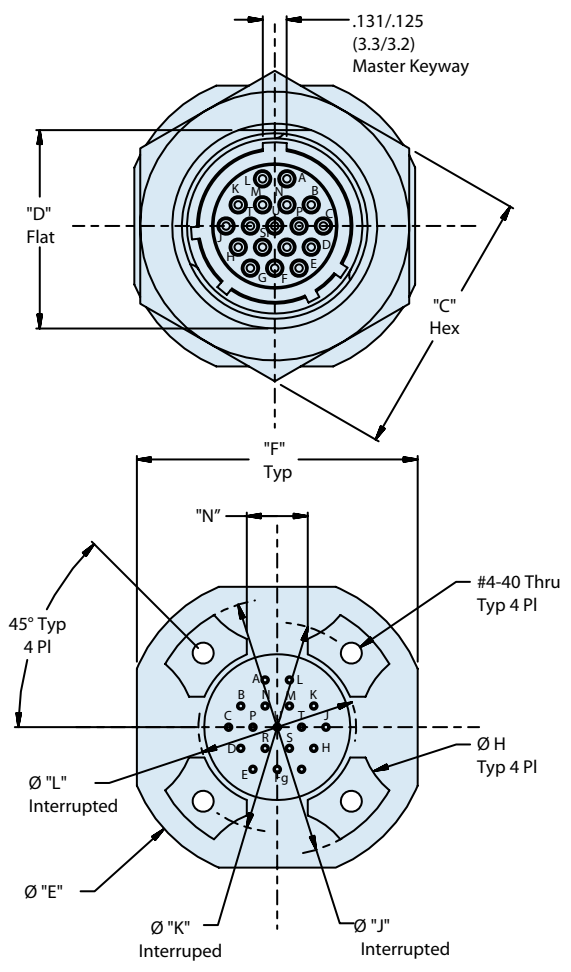
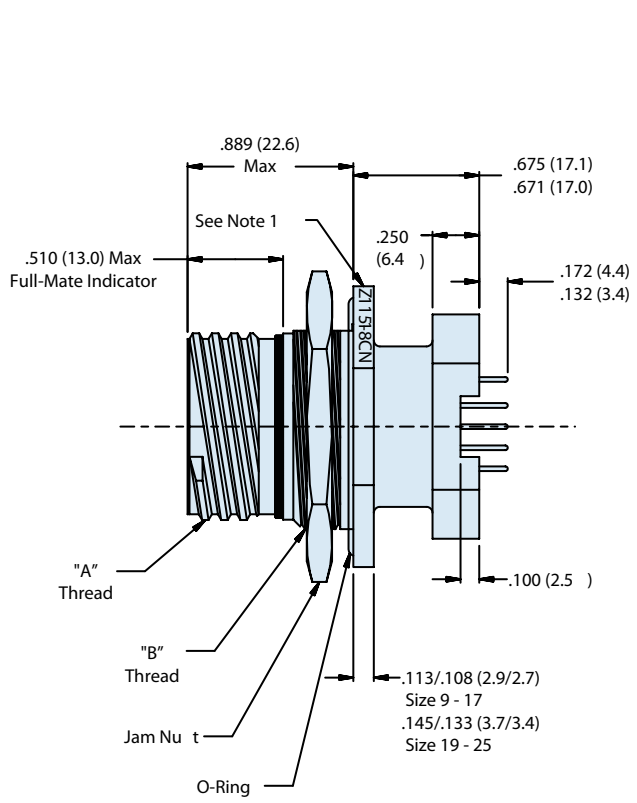
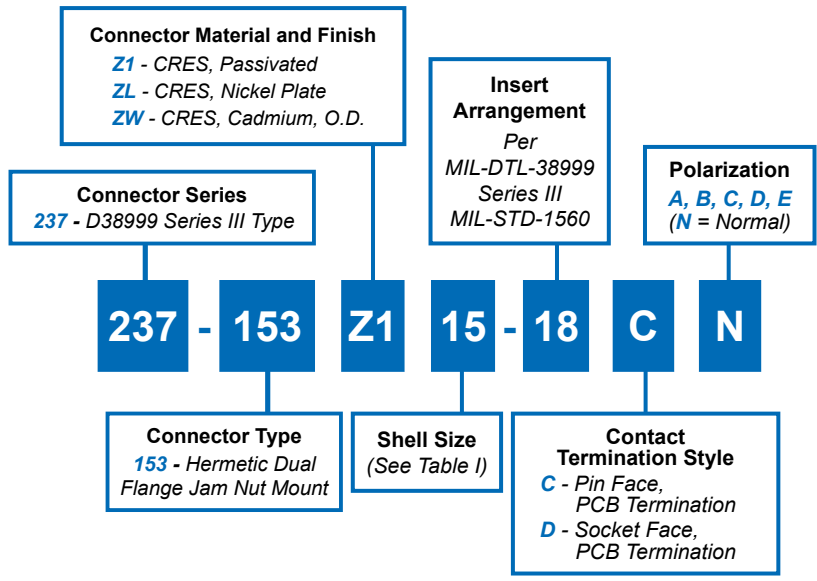

Dimensions in Inches (millimeters) are subject to change without notice.

# 237-153 Hermetic Dual Flange Jam Nut Mount Receptacle for MIL-DTL-38999 Series III Type



**TABLE I: Shell Size, Thread  
and Connector Dimensions (Continued Below)**

Shell Size	A Thread -0.1P-0.03L-TS (Plated)	B Thread Metric (Plated)	C ± .015 (0.38)	D ± .005 (0.13)	Ø E ± .012 (0.30)	F ± .016 (0.41)
<b>9</b> See Note 5	.6250	M17 x 1-6g-0.10R	.875 (22.2)	.651 (16.5)	1.250 (31.8)	1.063 (27.0)
<b>11</b>	.7500	M20 x 1-6g-0.10R	1.000 (25.4)	.751 (19.1)	1.377 (35.0)	1.259 (32.0)
<b>13</b>	.8750	M25 x 1-6g-0.10R	1.187 (30.1)	.937 (23.8)	1.500 (38.1)	1.374 (34.9)
<b>15</b>	1.0000	M28 x 1-6g-0.10R	1.375 (34.9)	1.063 (27.0)	1.625 (41.3)	1.500 (38.1)
<b>17</b>	1.1875	M32 x 1-6g-0.10R	1.437 (36.5)	1.187 (30.2)	1.750 (44.5)	1.625 (41.3)
<b>19</b>	1.2500	M35 x 1-6g-0.10R	1.562 (39.7)	1.311 (33.3)	1.937 (49.2)	1.822 (46.3)
<b>21</b>	1.3750	M38 x 1-6g-0.10R	1.750 (44.5)	1.434 (36.4)	2.063 (52.4)	1.940 (49.3)
<b>23</b>	1.5000	M41 x 1-6g-0.10R	1.875 (47.6)	1.561 (39.7)	2.190 (55.6)	2.073 (52.7)
<b>25</b>	1.6250	M44 x 1-6g-0.10R	2.000 (50.8)	1.687 (42.9)	2.311 (58.7)	2.189 (55.6)

**TABLE III:  
Contact Size  
and Diameter**

Contact Size	Ø P
<b>22</b>	.022/.018 (0.56/0.46)
<b>20</b>	.027/.023 (0.69/0.58)
<b>16</b>	.042/.038 (1.07/0.97)
<b>12</b>	.052/.048 (1.32/1.22)

**TABLE I: Shell Size, Thread  
and Connector Dimensions (Continued from Above)**

Shell Size	H ± .020 (0.51)	Ø J ± .005 (0.13)	Ø K Basic	L ± .005 (0.13)	N ± .020 (0.51)	R ± .005 (.13)	S ± .005 (.13)
<b>9</b>	.225 (5.7)	1.016 (25.8)	.752 (19.1)	.532 (13.5)	.275 (7.0)	.698 (17.73)	.661 (16.79) .655 (16.64)
<b>11</b>	.250 (6.4)	1.062 (27.0)	.850 (21.6)	.595 (15.1)	.290 (7.4)	.830 (21.08)	.766 (19.46)
<b>13</b>	.375 (9.5)	1.250 (31.8)	.994 (25.2)	.720 (18.3)	.370 (9.4)	1.015 (25.78)	.950 (24.13)
<b>15</b>	.438 (11.1)	1.375 (34.9)	1.119 (28.4)	.843 (21.4)	.440 (11.2)	1.140 (28.96)	1.080 (27.43)
<b>17</b>	.562 (14.3)	1.500 (38.1)	1.237 (31.4)	1.000 (25.4)	.495 (12.6)	1.265 (32.13)	1.205 (30.61)
<b>19</b>	.875 (22.2)	1.625 (41.3)	1.379 (35.0)	1.125 (28.6)	.540 (13.7)	1.390 (35.31)	1.330 (33.78)
<b>21</b>	1.170 (29.7)	1.750 (44.5)	1.489 (37.8)	1.240 (31.5)	.625 (15.9)	1.515 (38.48)	1.455 (36.96)
<b>23</b>	1.250 (31.8)	1.875 (47.6)	1.619 (41.1)	1.328 (33.7)	.660 (16.8)	1.640 (41.66)	1.580 (40.13)
<b>25</b>	1.375 (34.9)	2.000 (50.8)	1.744 (44.3)	1.453 (36.9)	.740 (18.8)	1.765 (44.83)	1.705 (43.31)

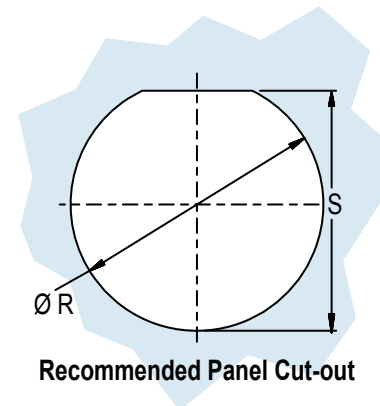

### APPLICATION NOTES

- |   |  |
|---|--|
| <ol style="list-style-type: none"> <li>Assembly identified with manufacturer's name and P/N, space permitting.</li> <li>Performance test criteria:<br/>Hermeticity – &lt;math&gt;1 \times 10^{-7}&lt;/math&gt; ccHe/sec @1 ATM differential.<br/>D.W.V. – per DTL-38999 pin-to-pin and pin-to-shell w/o breakdown<br/>I.R. – 5000 MegOhms min @ 500 VDC.</li> <li>Glenair 237-153 receptacle connector is designed to mate with and QPL manufacturer's MIL-DTL-38999 Series III plug connector having the same shell size, insert arrangement, polarization and opposite contact gender.</li> <li>Metric dimensions (mm) are indicated in parentheses.</li> </ol> | <ol style="list-style-type: none"> <li>Material/finish:<br/>Shell, jam nut – CRES/per part number development.<br/>Pin Contacts – Nickel iron alloy 52/gold plated.<br/>Socket Contacts – Copper alloy/52 gold plated.<br/>Socket Hoods – CRES/Passivate.<br/>Insulator, Pins – full glass/N.A.<br/>Insulator, Sockets – Rigid dielectric/N.A.<br/>Seals – Fluorosilicone/N.A.<br/>O-Ring – Cho-Seal 1298/ N.A.</li> </ol> |
|---|--|

Dimensions in Inches (millimeters) are subject to change without notice.



**257-093**  
**Jam Nut Mount Hermetic Bulkhead Feed-Thru**  
**MIL-DTL-38999 Series III Type**

**B**

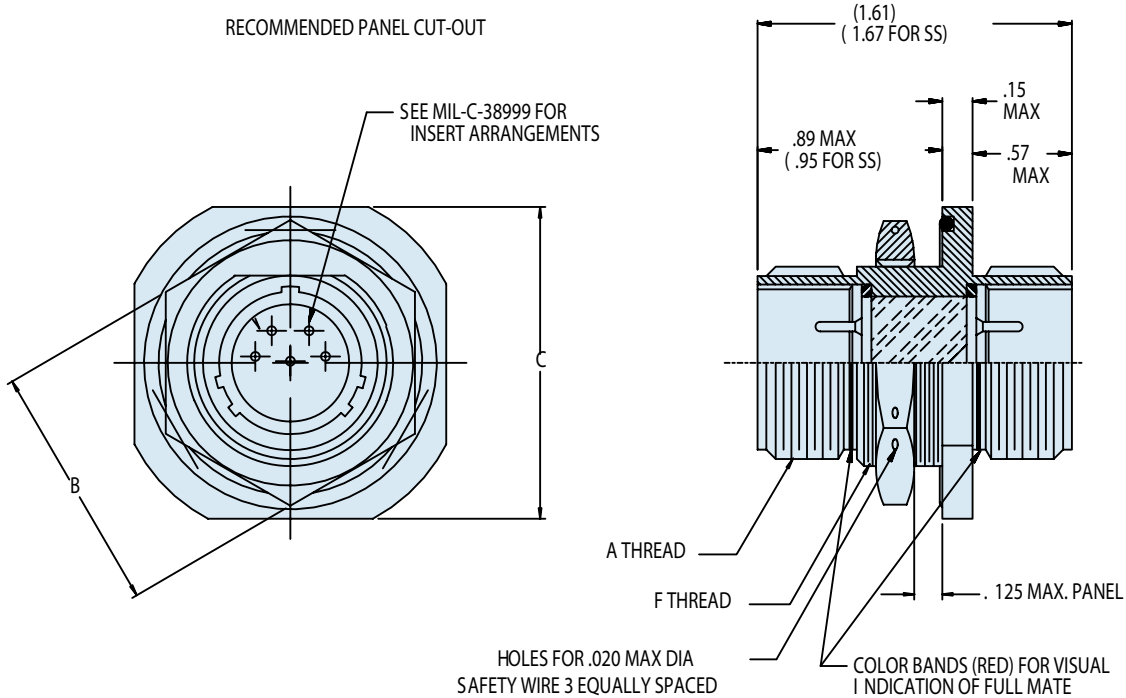
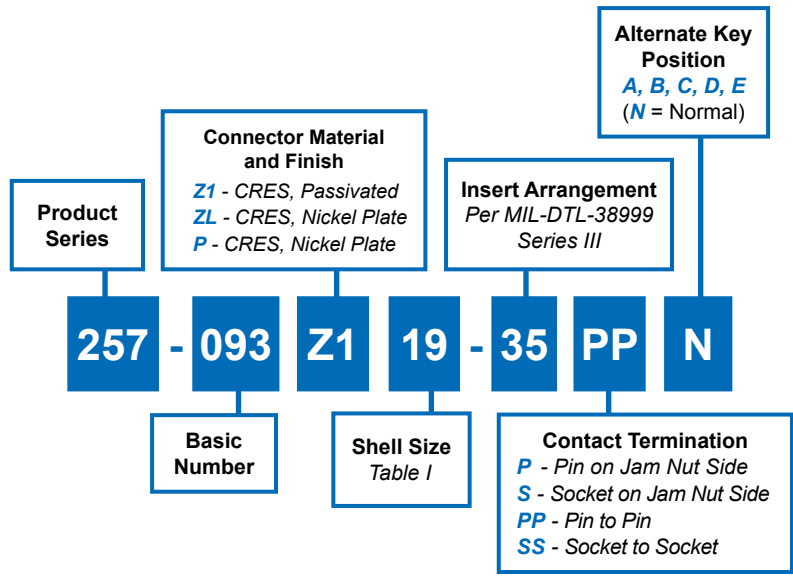

Dimensions in Inches (millimeters) are subject to change without notice.

**257-093**  
**Jam Nut Mount Hermetic Bulkhead Feed-Thru**  
**MIL-DTL-38999 Series III Type**



HERMETIC LEAK RATE MOD CODES	
Designator	Required Leak Rate
-585A	1 x 10 <sup>-10</sup> cc Helium per second
-585B	1 x 10 <sup>-9</sup> cc Helium per second
-585C	1 x 10 <sup>-8</sup> cc Helium per second

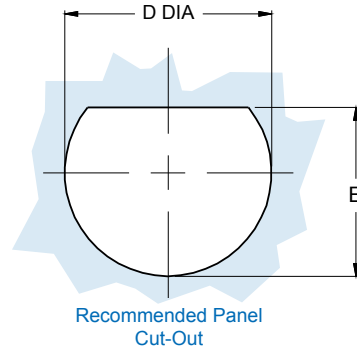

TABLE I: CONNECTOR DIMENSIONS						
SHELL SIZE	A THREAD 0.1 P-0.3L-TS-2	B DIM	C DIM MAX	D DIA	E DIM	F THREAD CLASS 2A
9	0.625	.875(22.2)	1.09(27.7)	.693 (17.60)	.657 (16.70)	11/16-24 UNEF
11	0.750	1.000(25.4)	1.28(32.5)	.825 (20.96)	.771 (19.59)	13/16-20 UNEF
13	0.875	1.250(31.8)	1.40(35.6)	1.010 (25.65)	.955 (24.26)	1-20 UNEF
15	1.000	1.375(34.9)	1.53(38.9)	1.135 (28.83)	1.085 (27.56)	1 1/8-18 UNEF
17	1.187	1.500(38.1)	1.66(42.2)	1.260 (32.01)	1.210 (30.73)	1 1/4-18 UNEF
19	1.250	1.625(41.3)	1.84(46.7)	1.385 (35.18)	1.335 (33.91)	1 3/8-18 UNEF
21	1.375	1.750(44.5)	1.97(50.5)	1.510 (38.35)	1.460 (37.08)	1 1/2-18 UNEF
23	1.500	1.875(47.6)	2.09(53.1)	1.635 (41.53)	1.585 (40.26)	1 5/8-18 UNEF
25	1.625	2.000(50.8)	2.21(56.1)	1.760 (44.70)	1.710 (43.43)	1 3/4-18 UNEF

**APPLICATION NOTES**

- |  |   |
|--|---|
| <ol style="list-style-type: none"> <li>Assembly identified with manufacturer's name and PN, space permitting.</li> <li>For pin/pin and socket/socket, symmetrical layouts only, consult factory for available insert arrangements.</li> <li>Electrical safety limits must be established by user, peak voltage, switching surge, transient, etc. should be used to determine the safety of the application.</li> </ol> | <ol style="list-style-type: none"> <li>Material/Finish:<br/>Shell, lock ring, jam nut—stainless steel/passivate<br/>Contacts—alloy 52/gold plate<br/>Sockets—copper alloy/gold plate<br/>Hermetic Insulator—full glass/N.A.<br/>Socket Insulator—rigid dielectric/N.A.<br/>Seals—fluorosilicone/ N.A.<br/>Hermeticity -1x10<sup>-7</sup> cc/second</li> <li>Metric dimensions (mm) are indicated in parentheses.</li> </ol> |
|--|---|

Dimensions in Inches (millimeters) are subject to change without notice.





**257-121**  
**Special Jam Nut Mount Hermetic Receptacle**  
**MIL-DTL-38999 Series III Type (D38999/23)**  
**with Accessory Threads**

**B**

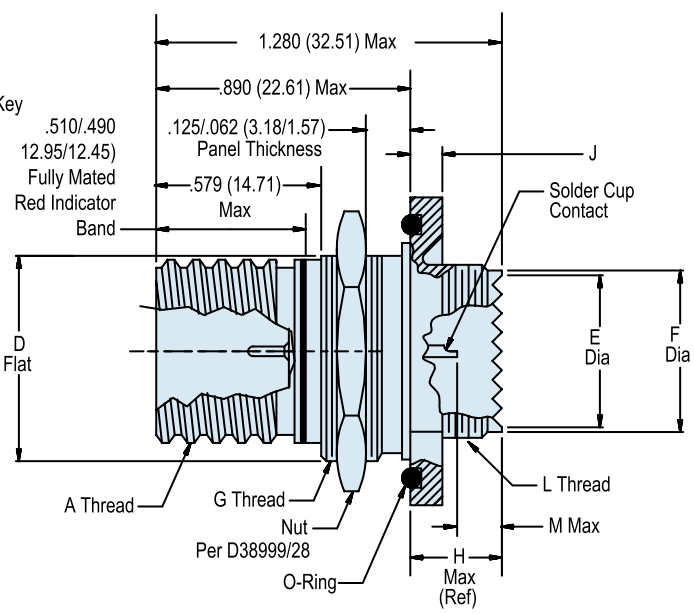
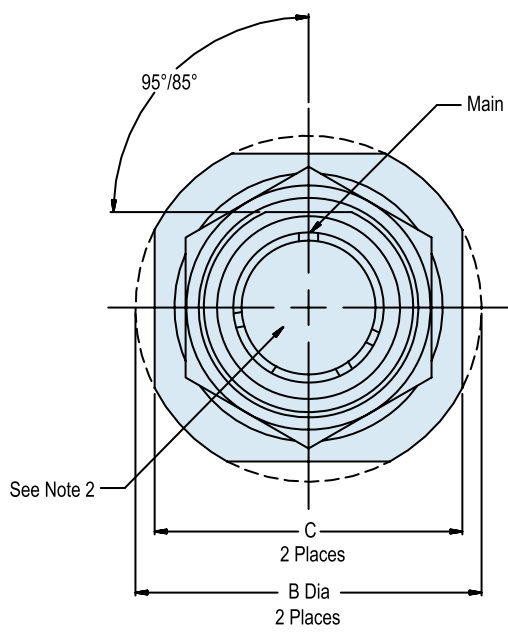
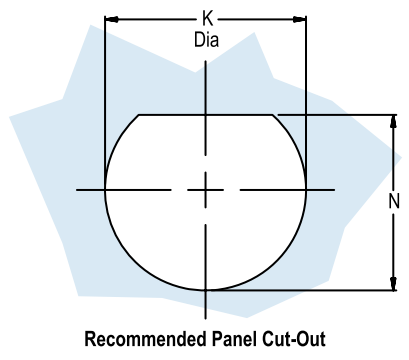
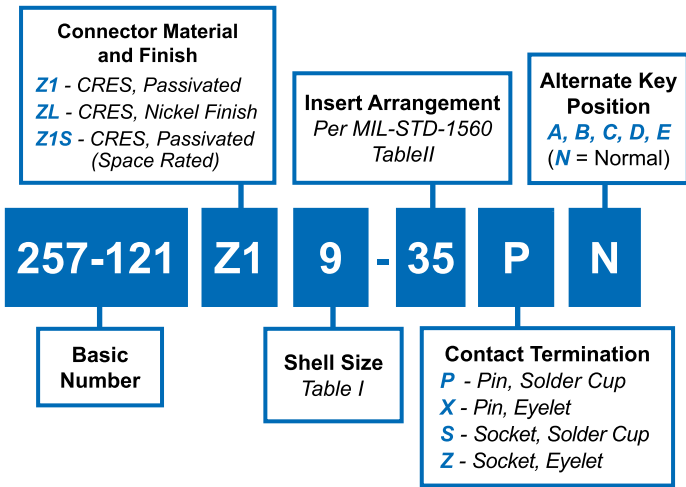

**APPLICATION NOTES**

- |  |   |
|--|---|
| <p>1. Assembly identified with manufacturer's name and PN, space permitting.</p> <p>2. Insert arrangement in accordance with MIL-STD-1560, See Table II.</p> <p>3. Glenair 257-121 receptacle connector is designed to mate with any QPL manufacturer's MIL-DTL-38999 Series III plug connector having the same insert arrangement, polarization, and opposite contact gender.</p> <p>4. Modified major diameter 31.95-31.80 (1.257-1.252)</p> | <p>5. <b>Material/Finish:</b><br/>                 Shell, Nut - CRES/nickel per QQ-N-290 or CRES/passivated<br/>                 Contacts - nickel iron alloy 52/gold<br/>                 Insulator - fused vitreous glass/N.A.<br/>                 Hermetic Insulator—fused vitreous glass/N.A.<br/>                 O-Ring and Seals - fluorosilicone rubber/ N.A.</p> <p>6. Metric dimensions (mm) are indicated in parentheses.</p> |
|--|---|

Dimensions in Inches (millimeters) are subject to change without notice.

257-121

Special Jam Nut Mount Hermetic Receptacle  
MIL-DTL-38999 Series III Type (D38999/23)  
with Accessory Threads



MIL-DTL-38999 Type  
Hermetic Connectors

B

**TABLE I: Shell Size, Shell Code, Thread and Dimensions (Continued Below)**

Shell Size	Shell Code Ref	A THREAD 0.1 P-0.3L-TS	B Dia	C A/F	D Flat	E Dia Max	F Dia	G THREAD ISO Metric
9	A	0.6250	1.200 (30.48) 1.177 (29.90)	1.078 (27.38) 1.047 (26.59)	.654 (16.61) .645 (16.38)	.346 (8.79)	.416 (10.57) .410 (10.41)	M17 X 1-6G 0.100R
11	B	0.7500	1.385 (35.18) 1.362 (34.59)	1.267 (32.18) 1.236 (31.39)	.754 (19.15) .745 (18.92)	.475 (12.07)	.534 (13.56) .528 (13.41)	M20 X 1-6G 0.100R
13	C	0.8750	1.511 (38.78) 1.488 (37.80)	1.390 (35.31) 1.358 (34.49)	.941 (23.90) .932 (23.67)	.589 (14.96)	.653 (16.59) .647 (16.43)	M25 X 1-6G 0.100R
15	D	1.0000	1.637 (41.58) 1.614 (41.00)	1.515 (38.48) 1.484 (37.69)	1.065 (27.05) 1.056 (26.82)	.714 (18.14)	.810 (20.57) .804 (20.42)	M28 X 1-6G 0.100R
17	E	1.1870	1.763 (44.78) 1.740 (44.20)	1.641 (41.68) 1.610 (40.89)	1.190 (30.23) 1.181 (30.00)	.839 (21.31)	.928 (23.57) .922 (23.42)	M32 X 1-6G 0.100R (See Note 4)
19	F	1.2500	1.949 (49.50) 1.925 (48.90)	1.826 (46.38) 1.795 (45.59)	1.315 (33.40) 1.306 (33.17)	.945 (24.00)	1.046 (26.57) 1.040 (26.42)	M35 X 1-6G 0.100R
21	G	1.3750	2.075 (52.71) 2.051 (52.10)	1.952 (49.59) 1.921 (48.79)	1.440 (36.58) 1.431 (36.35)	1.070 (27.18)	1.164 (29.57) 1.158 (29.41)	M38 X 1-6G 0.100R
23	H	1.5000	2.200 (55.88) 2.177 (55.30)	2.078 (52.78) 2.047 (51.99)	1.565 (39.75) 1.556 (39.52)	1.194 (30.33)	1.282 (32.56) 1.276 (32.41)	M41 X 1-6G 0.100R
25	J	1.6250	2.323 (59.00) 2.299 (58.39)	2.204 (55.98) 2.173 (55.19)	1.690 (42.93) 1.681 (42.70)	1.320 (33.53)	1.400 (35.56) 1.394 (35.41)	M44 X 1-6G 0.100R

**TABLE I: Shell Size, Shell Code, Thread and Dimensions (Continued from Above)**

Shell Size	Shell Code Ref	H Max	J	K Dia	L THREAD ISO Metric	M Max	N
9	A	.390 (9.91)	.122 (3.10) .083 (2.11)	.703 (17.86) .693 (17.60)	M12 X 1-6G 0.100R	.200 (5.08)	.661 (16.79) .655 (16.64)
11	B	.390 (9.91)	.122 (3.10) .083 (2.11)	.835 (21.21) .825 (20.96)	M15 X 1-6G 0.100R	.200 (5.08)	.771 (19.58) .761 (19.33)
13	C	.390 (9.91)	.122 (3.10) .083 (2.11)	1.020 (25.91) 1.010 (25.65)	M18 X 1-6G 0.100R	.200 (5.08)	.955 (24.26) .945 (24.00)
15	D	.390 (9.91)	.122 (3.10) .083 (2.11)	1.145 (29.08) 1.135 (28.83)	M22 X 1-6G 0.100R	.200 (5.08)	1.085 (27.56) 1.075 (27.31)
17	E	.390 (9.91)	.122 (3.10) .083 (2.11)	1.270 (32.26) 1.260 (32.00)	M25 X 1-6G 0.100R	.200 (5.08)	1.210 (30.73) 1.200 (30.48)
19	F	.390 (9.91)	.153 (3.89) .114 (2.90)	1.395 (35.43) 1.385 (35.18)	M28 X 1-6G 0.100R	.200 (5.08)	1.335 (33.91) 1.325 (33.66)
21	G	.390 (9.91)	.153 (3.89) .114 (2.90)	1.520 (38.61) 1.510 (38.35)	M31 X 1-6G 0.100R	.200 (5.08)	1.460 (37.08) 1.450 (36.83)
23	H	.390 (9.91)	.153 (3.89) .114 (2.90)	1.645 (41.78) 1.635 (41.53)	M34 X 1-6G 0.100R	.200 (5.08)	1.585 (40.26) 1.575 (40.01)
25	J	.390 (9.91)	.153 (3.89) .114 (2.90)	1.770 (44.96) 1.760 (44.70)	M37 X 1-6G 0.100R	.200 (5.08)	1.710 (43.43) 1.700 (43.18)

**TABLE II: Layouts and Pin Counts**

Pattern	9-98	9-35	11-4	11-5	11-98	11-99	11-35	11-2	13-4	13-8	13-98	13-35	15-5	15-15	15-18	15-19	15-97	15-35	17-6	17-8	17-26	17-99	17-35	19-11	19-28	19-30	19-32	
22D		6					13					22						37					55					
20	3		4	5	6	7				8	10			14	18	19	8				26	21				26	29	32
16								2	4				5	1			4			8					11	2	1	
12																			6									
Pattern	19-35	19-45	21-11	21-16	21-24	21-25	21-27	21-41	21-39	21-35	23-35	23-21	23-32	23-34	23-36	23-53	23-97	23-99	23-55	25-35	25-29	25-61	25-4	25-43	25-19	25-24		
22D	66	67								79	100									128								
20					24	25	27	41	37				32	34	36	53				55		61	48	23				
16				16					2								16	11					8	20				
12			11																						19	12		

Dimensions in Inches (millimeters) are subject to change without notice.



**947-082**  
**Jam Nut Mount Hermetic Bulkhead Feed-Thru**  
.500/.625 inch Panel  
MIL-DTL-38999 Series III Type

**B**

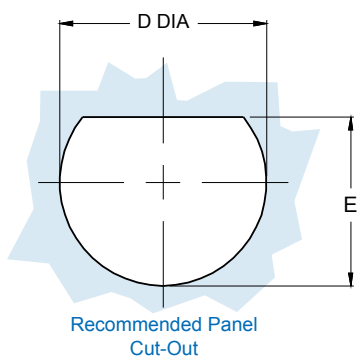
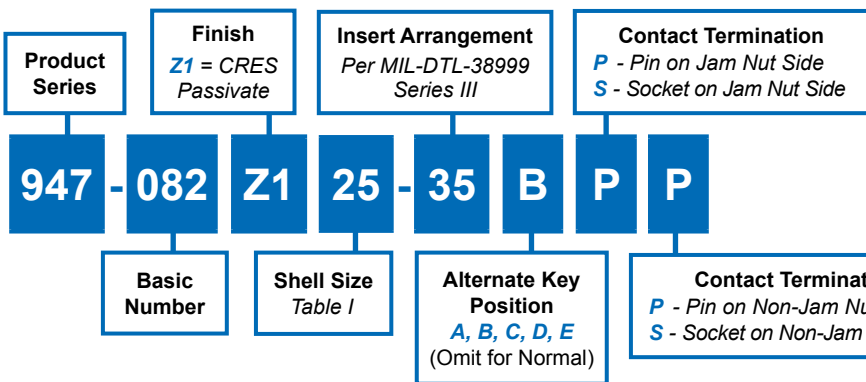

HERMETIC LEAK RATE MOD CODES	
Designator	Required Leak Rate
-585A	1 x 10 <sup>-10</sup> cc Helium per second
-585B	1 x 10 <sup>-9</sup> cc Helium per second
-585C	1 x 10 <sup>-8</sup> cc Helium per second

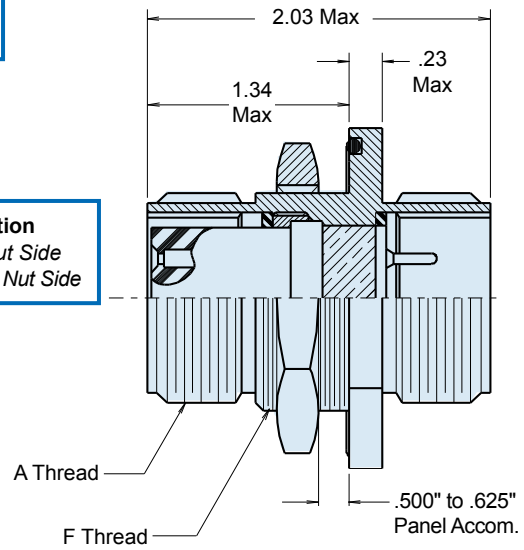

Insert Arrangement per MIL-DTL-38999 Series III MIL-STD-1560

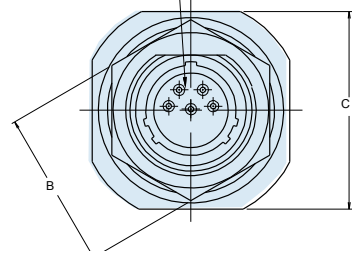
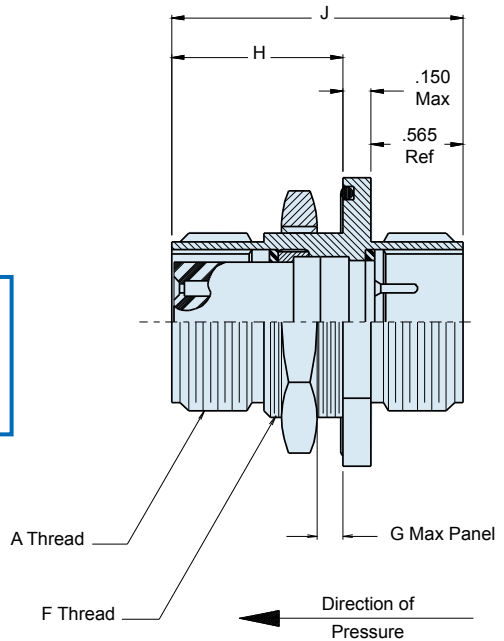
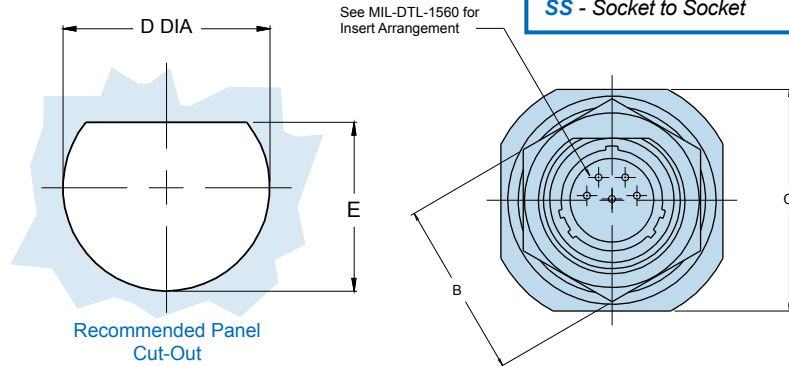
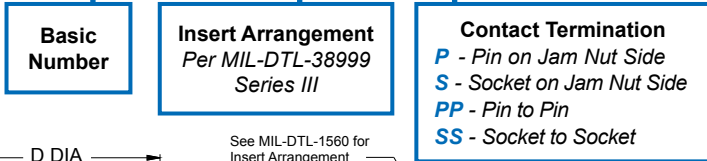
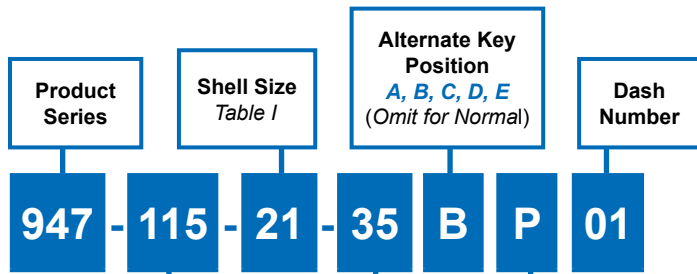

TABLE I: CONNECTOR DIMENSIONS						
SHELL SIZE	A THREAD 0.1 P-0.3L-TS-2	B DIM	C DIM MAX	D DIA	E DIM	F THREAD 1-6g 0.100R
09	.6250	.875(22.2)	1.090(27.7)	.693 (17.60)	.657 (16.70)	M17
11	.7500	1.000(25.4)	1.280(32.5)	.825 (20.96)	.771 (19.59)	M20
13	.8750	1.250(31.8)	1.400(35.6)	1.010 (25.80)	.955 (24.26)	M25
15	1.0000	1.375(34.9)	1.530(38.9)	1.135 (25.65)	1.085 (27.56)	M28
17	1.1875	1.500(38.1)	1.660(42.2)	1.260 (28.83)	1.210 (30.73)	M32
19	1.2500	1.625(41.3)	1.840(46.7)	1.385 (32.01)	1.335 (33.91)	M35
21	1.3750	1.750(44.5)	1.970(50.5)	1.510 (35.18)	1.460 (37.08)	M38
23	1.5000	1.875(47.6)	2.090(53.1)	1.635 (41.53)	1.585 (40.26)	M41
25	1.6250	2.000(50.8)	2.210(56.1)	1.760 (44.70)	1.710 (43.43)	M44

APPLICATION NOTES	
1. Power to a given contact on one end will result in power to contact directly opposite, regardless of identification letter.	Contacts – Gold Plated. Pin: alloy 52; Skt.: copper alloy
2. Hermeticity = less than 1 x 10 <sup>-7</sup> cc/sec at one atmosphere. Not for use in liquid atmosphere.	Insulator – fused vitreous glass/N.A.
3. Material/finish: Shell, nut – CRES/passivated, carbon steel/fused tin or CRES/nickel per QQ-N-290.	Seals – fluorosilicone rubber/N.A.
	4. Metric dimensions (mm) are indicated in parentheses.

Dimensions in Inches (millimeters) are subject to change without notice.

**947-115**  
**Jam Nut Mount Hermetic Bulkhead Feed-Thru**  
 .250/.500 inch Panel  
 MIL-DTL-38999 Series III Type



B

**TABLE I: CONNECTOR DIMENSIONS**

SHELL SIZE	A THREAD 0.1 P-0.3L- TS-2	B DIM	C DIM MAX	D DIA	E DIM	F THREAD x1-6g-0.100R
9	0.625	.875(22.2)	1.09(27.7)	.693 (17.60)	.657 (16.70)	M17
11	0.750	1.000(25.4)	1.28(32.5)	.825 (20.96)	.771 (19.59)	M20
13	0.875	1.250(31.8)	1.40(35.6)	1.010 (25.80)	.955 (24.26)	M25
15	1.000	1.375(34.9)	1.53(38.9)	1.135 (25.65)	1.085 (27.56)	M28
17	1.187	1.500(38.1)	1.66(42.2)	1.260 (28.83)	1.210 (30.73)	M32
19	1.250	1.625(41.3)	1.84(46.7)	1.385 (32.01)	1.335 (33.91)	M35
21	1.375	1.750(44.5)	1.97(50.5)	1.510 (35.18)	1.460 (37.08)	M38
23	1.500	1.875(47.6)	2.09(53.1)	1.635 (41.53)	1.585 (40.26)	M41
25	1.625	2.000(50.8)	2.21(56.1)	1.760 (44.70)	1.710 (43.43)	M44

HERMETIC LEAK RATE MOD CODES	
Designator	Required Leak Rate
-585A	1 x 10 <sup>-10</sup> cc Helium per second
-585B	1 x 10 <sup>-9</sup> cc Helium per second
-585C	1 x 10 <sup>-8</sup> cc Helium per second

**TABLE III: PANEL THICKNESS**

DASH NO	G MAX	H MAX	J MAX
01	.250(6.4)	1.08(27.4)	1.79(45.5)
02	.500(12.7)	1.33(33.8)	2.04(51.8)

**APPLICATION NOTES**

1. Assembly identified with manufacturer's name and PN, space permitting.
2. For pin/pin and skt/skt, symmetrical layouts only, consult factory for available insert arrangements.
3. Power to a given contact on one end will result in power to contact directly opposite, regardless of identification letter.
4. Hermeticity = less than 1 x 10<sup>-7</sup> cc/sec at one atmosphere. Not for use in liquid atmosphere.
5. Electrical safety limits must be established by user, peak voltage, switching surge, transient, etc. should be used to determine the safety of the application.
6. Material/finish:  
 Shell, lock ring, jam nut—stainless steel/passivate  
 Contacts—copper alloy/gold plate and alloy 52/gold plate  
 Insulators—high-grade rigid dielectric/N.A. and full glass.  
 Seals—fluorosilicone/ N.A.
7. Metric dimensions (mm) are indicated in parentheses.

Dimensions in Inches (millimeters) are subject to change without notice.



**947-282**  
**Flange Mount Hermetic Bulkhead Feed-Thru**  
**MIL-DTL-38999/21 Series III Type**

**B**

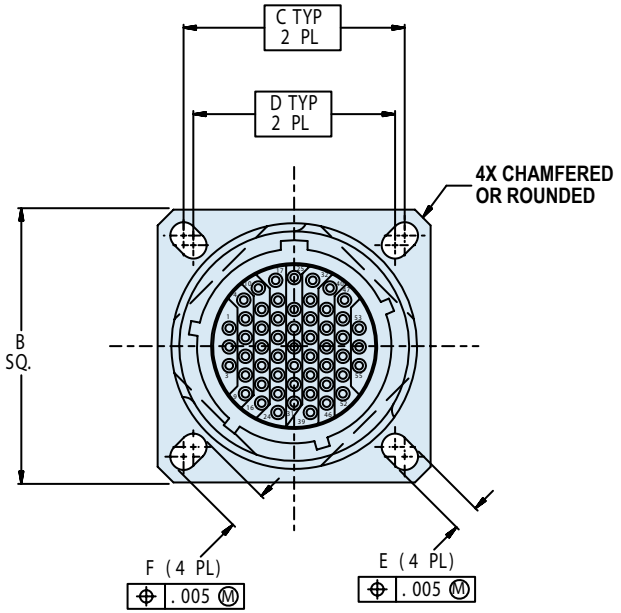
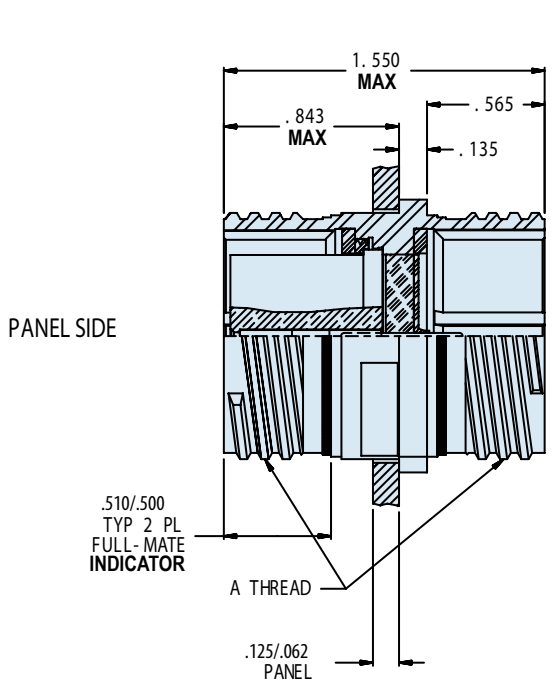
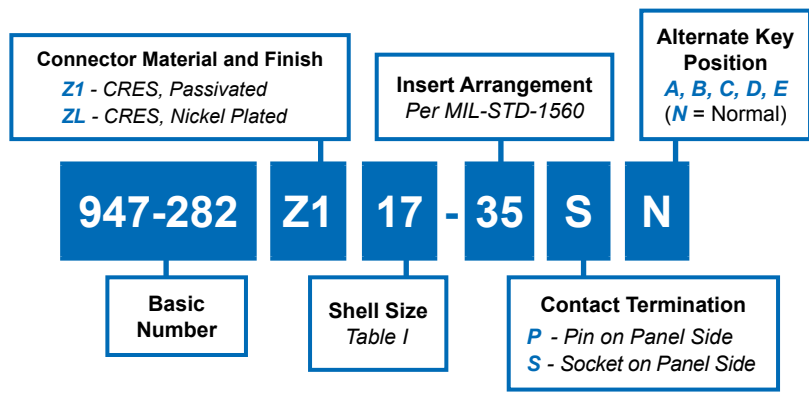

Dimensions in Inches (millimeters) are subject to change without notice.

947-282  
 Flange Mount Hermetic Bulkhead Feed-Thru  
 MIL-DTL-38999/21 Series III Type



TABLE I: CONNECTOR DIMENSIONS

SHELL SIZE	A THREAD 0.1 P-0.3L-TS-2	B SQ.	C BASIC	D BASIC	E	F	Ø H MIN.	Ø G HOLES	K
9	0.625	.949 .925	.719	.594	.136 .120	.224 .208	.656	.133 .123	.724 .714
11	0.750	1.043 1.019	.812	.719		.202 .186	.781		.817 .807
13	0.875	1.138 1.114	.906	.812		.202 .186	.921		.911 .901
15	1.000	1.232 1.208	.969	.906		.181 .165	1.047		.973 .963
17	1.187	1.323 1.299	1.062	.969		.202 .186	1.218		1.067 1.057
19	1.250	1.449 1.425	1.156	1.062		.202 .186	1.296		1.161 1.151
21	1.375	1.575 1.551	1.250	1.156		.202 .186	1.421		1.255 1.245
23	1.500	1.701 1.677	1.375	1.250	.162 .146	.250 .234	1.546	.159 .149	1.380 1.370
25	1.625	1.823 1.799	1.500	1.375		.250 .234	1.672		1.505 1.495

HERMETIC LEAK RATE MOD CODES	
Designator	Required Leak Rate
-585A	1 x 10 <sup>-10</sup> cc Helium per second
-585B	1 x 10 <sup>-9</sup> cc Helium per second
-585C	1 x 10 <sup>-8</sup> cc Helium per second

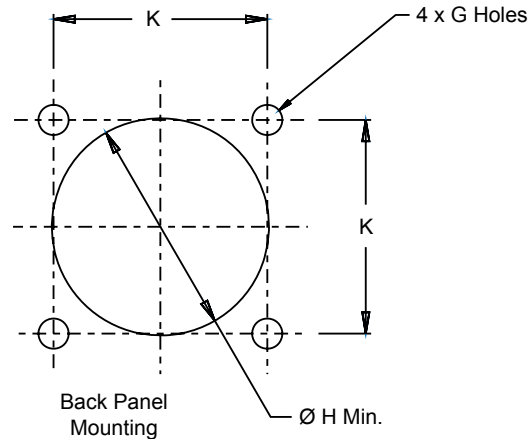

APPLICATION NOTES

- Assembly identified with manufacturer's name and PN, space permitting.
- Material/Finish:  
 Shell, lock ring, jam nut—CRES/passivate or CRES/nickel plate  
 Pin Contacts—nickel iron alloy/gold plate  
 Socket Contacts—copper alloy/gold plate  
 Insulator, Hermetic—vitreous glass/N.A.  
 Insulator, Socket—rigid dielectric/N.A.  
 Socket Insulator—high grade rigid dielectric/N.A.  
 Seals—fluorosilicone blend/ N.A.
- Electrical safety limits must be established by user, peak voltage, switching surge, transient, etc. Should be used to determine the safety application.
- Hermeticity <1 x 10<sup>-7</sup> cc He/sec at 1 ATM differential
- Glenair 947-282 will mate with any QPL manufacturers D38999 series III plugs of same shell size, broach position, and opposite contact gender.
- Metric dimensions (mm) are indicated in parentheses.

Dimensions in Inches (millimeters) are subject to change without notice.





# D38999/41 Box Mount Hermetic Receptacle MIL-DTL-38999 Series IV

## How To Order: MS

**B**

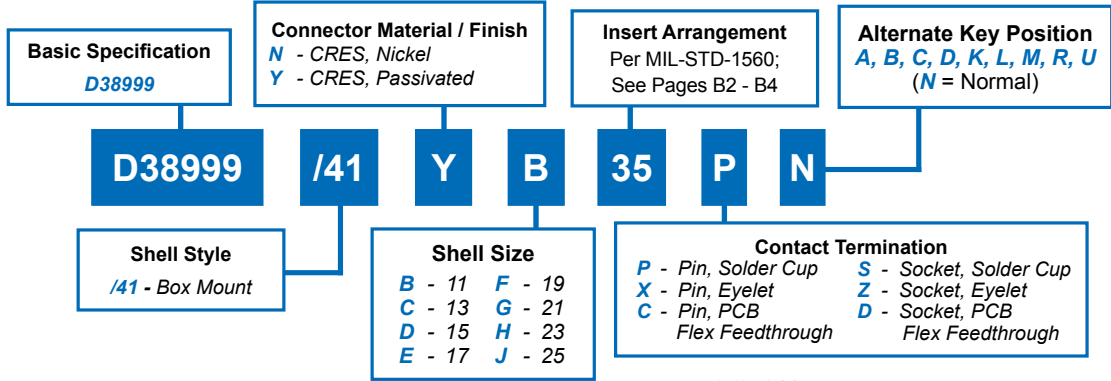

**TABLE II: CONTACT SIZE**

PRINTED CIRCUIT TAIL CONFIGURATIONS  
CONTACT STYLE C AND D

Contact Size	ø P
22D	.011 (0.28) .015 (0.38)
20	.024 (0.61) .028 (0.71)
16	.0635 (1.61) .0615 (1.56)
12	.095 (2.41) .093 (2.36)

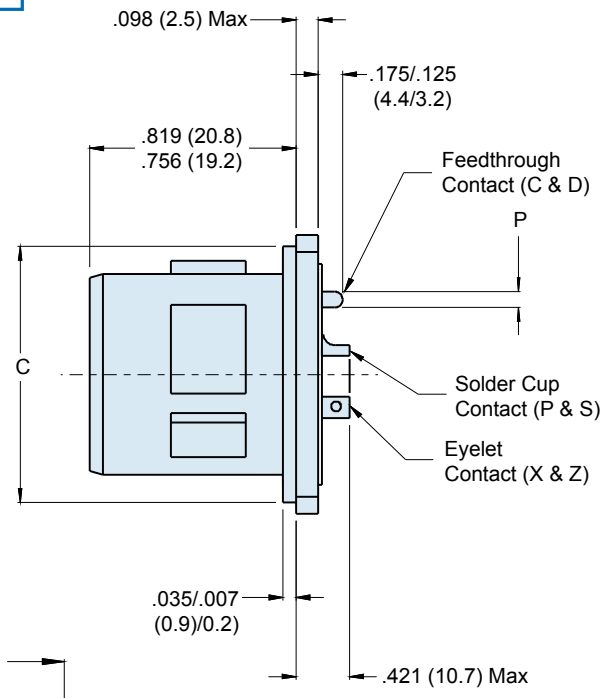

**WIRE ACCOMODATION**

Contact Size	Wire Gauge
22D	#22 - #28
20	#20 - #24
16	#16 - #20
12	#12 - #14

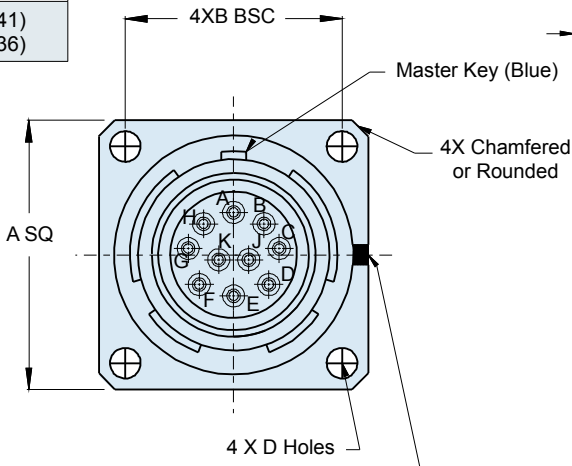

Full-Mate Indicator (Blue)  
 Dimensions in Inches (millimeters) are subject to change without notice.

# 234-100-H2 Box Mount Hermetic Receptacle MIL-DTL-38999 Series IV Type



## How To Order: Commercial

**234 - 100 - H2      Z1    11 - 35    P    N**

**Connector Series**  
*234 - Series IV Type*

**Shell Style**  
*H2 - Hermetic Box Mount*

**Shell Size**  
*11,13,15,17,19,21,23,25*

**Contact Termination**  
*P - Pin, Solder Cup    S - Socket, Solder Cup*  
*X - Pin, Eyelet        Z - Socket, Eyelet*  
*C - Pin, PCB            D - Socket, PCB*

**Connector Type**  
*100 - Hermetic Receptacle*

**Connector Material / Finish**  
*ZL - CRES, Nickel*  
*Z1 - CRES, Passivated*

**Insert Arrangement**  
*Per MIL-STD-1560;*  
*See Pages B-2 - B-4*

**Alternate Key Position**  
*A, B, C, D, K, L, M, R, U*  
*(N = Normal)*

234-100-H2  
 Supersedes original  
 DLA equivalent part  
 number 230-010

HERMETIC LEAK RATE MOD CODES	
Designator	Required Leak Rate
-585A	1 x 10 <sup>-10</sup> cc Helium per second
-585B	1 x 10 <sup>-9</sup> cc Helium per second
-585C	1 x 10 <sup>-8</sup> cc Helium per second

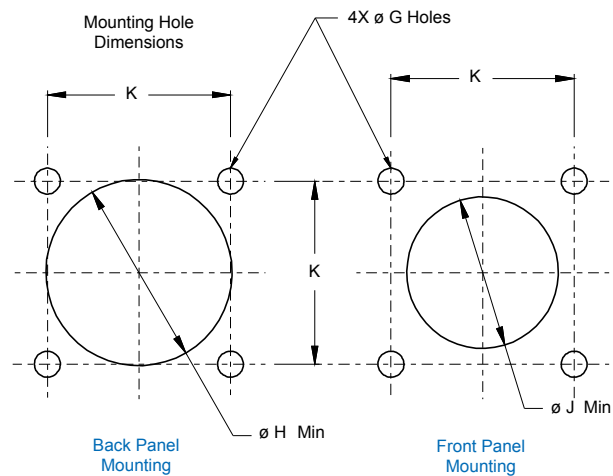

TABLE I: CONNECTOR DIMENSIONS									
SHELL SIZE CODE	SHELL SIZE	A SQ	B BSC	C DIA	D DIA	øG HOLES ±.005(0.1)	øH MIN	øJ MIN	K ±.005(0.1)
B	11	1.051(26.7) 1.008(25.6)	.812(20.6)	.793(20.1) .778(19.8)	.138(3.5) .122(3.1)	.128(3.3)	.781(19.8)	.625(15.9)	.812(20.6)
C	13	1.145(29.1) 1.102(28.0)	.906(23.0)	.919(23.3) .904(23.0)	.138(3.5) .122(3.1)	.128(3.3)	.921(23.4)	.750(19.1)	.906(23.0)
D	15	1.240(31.5) 1.197(30.4)	.969(24.6)	1.044(26.5) 1.029(26.1)	.138(3.5) .122(3.1)	.128(3.3)	1.047(26.6)	.906(23.0)	.968(24.6)
E	17	1.334(33.9) 1.291(32.8)	1.062(27.0)	1.170(29.7) 1.155(29.3)	.138(3.5) .122(3.1)	.128(3.3)	1.218(30.9)	1.016(25.8)	1.062(27.0)
F	19	1.460(37.1) 1.417(36.0)	1.156(29.4)	1.294(32.9) 1.279(32.5)	.138(3.5) .122(3.1)	.128(3.3)	1.296(32.9)	1.142(29.0)	1.156(29.4)
G	21	1.583(40.2) 1.539(39.1)	1.250(31.8)	1.419(36.0) 1.404(35.7)	.138(3.5) .122(3.1)	.128(3.3)	1.421(36.1)	1.266(32.2)	1.250(31.8)
H	23	1.709(43.4) 1.665(42.3)	1.375(34.9)	1.544(39.2) 1.529(38.8)	.157(4.0) .142(3.6)	.154(3.9)	1.546(39.3)	1.375(34.9)	1.375(34.9)
J	25	1.835(46.6) 1.791(45.5)	1.500(38.1)	1.670(42.4) 1.654(42.0)	.157(4.0) .142(3.6)	.154(3.9)	1.672(42.5)	1.484(37.7)	1.500(38.1)

Dimensions in Inches (millimeters) are subject to change without notice.



# D38999/43 Jam Nut Mount Hermetic Receptacle MIL-DTL-38999 Series IV

## How To Order: MS

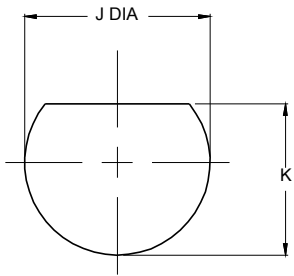
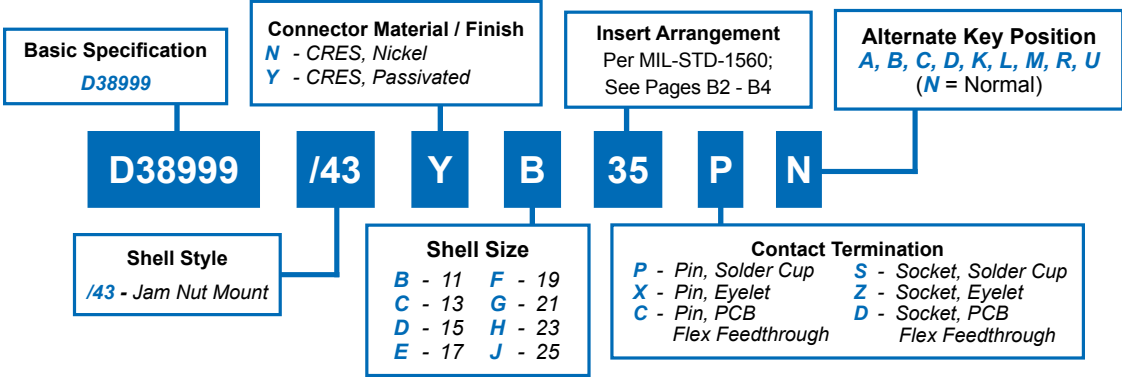

Recommended Panel Cut-Out

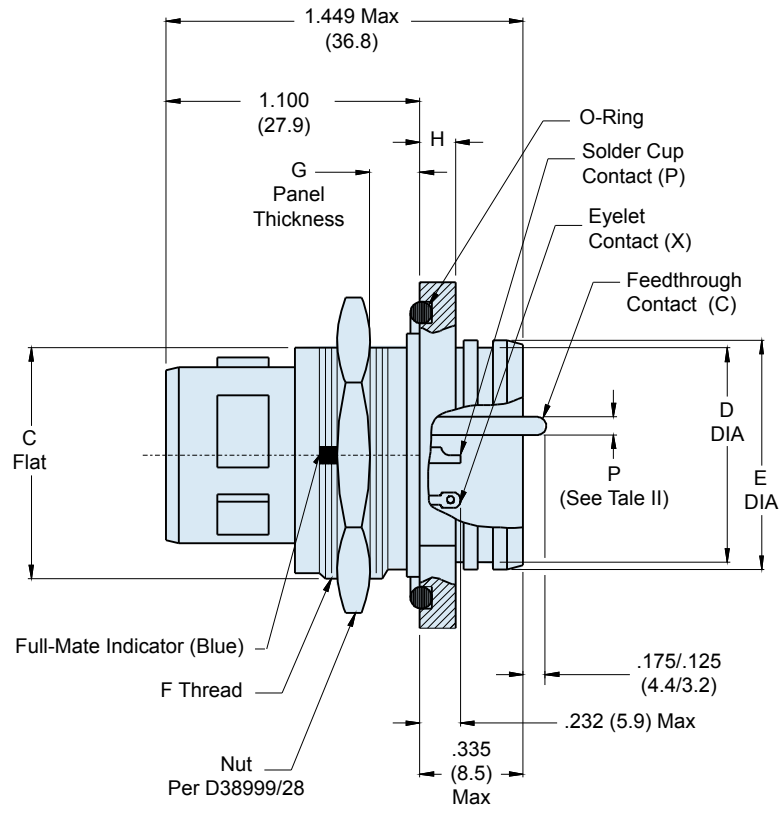
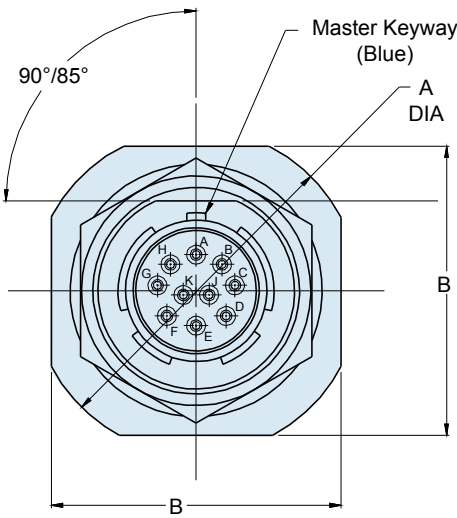

Dimensions in Inches (millimeters) are subject to change without notice.

# 234-100-H7 Jam Nut Mount Hermetic Receptacle MIL-DTL-38999 Series IV Type



MIL-DTL-38999 Type  
Hermetic Connectors

## How To Order: Commercial

<b>Connector Series</b> 234 - Series IV Type	<b>Shell Style</b> H7 - Hermetic Jam Nut Mount	<b>Shell Size</b> 11, 13, 15, 17, 19, 21, 23, 25	<b>Contact Termination</b> P - Pin, Solder Cup    S - Socket, Solder Cup X - Pin, Eyelet        Z - Socket, Eyelet C - Pin, PCB            D - Socket, PCB				
<b>234</b>	<b>100</b>	<b>H7</b>	<b>Z1</b>	<b>11</b>	<b>35</b>	<b>P</b>	<b>N</b>
<b>234-100-H7</b> Supercedes original DLA equivalent part number 230-011	<b>Connector Type</b> 100 - Hermetic Receptacle	<b>Connector Material / Finish</b> ZL - CRES, Nickel Z1 - CRES, Passivated	<b>Insert Arrangement</b> Per MIL-STD-1560; See Pages B-2 - B-4	<b>Alternate Key Position</b> A, B, C, D, K, L, M, R, U (N = Normal)			

SHELL SIZE CODE	SHELL SIZE	A DIA	B FLATS ±.018(0.5)	C FLAT	D DIA	E DIA ±.010(0.3)	F THREAD ISO METRIC	G ±.033(0.8)	H ±.012(0.3)
B	11	1.362(34.6)	1.250(31.8)	.754(19.2) .745(18.9)	.733(18.6) .716(18.2)	.769(19.5)	M20 X 1.0-6g	.092(2.3)	.106(2.7)
C	13	1.511(38.4) 1.488(37.8)	1.376(35.0)	.941(23.9) .932(23.7)	.858(21.8) .839(21.3)	.899(22.8)	M25 X 1.0-6g	.092(2.3)	.106(2.7)
D	15	1.637(41.6) 1.614(41.0)	1.502(38.2)	1.065(27.1) 1.056(26.8)	.984(25.0) .968(24.6)	1.025(26.0)	M28 X 1.0-6g	.092(2.3)	.106(2.7)
E	17	1.763(44.8) 1.740(44.2)	1.624(41.2)	1.190(30.2) 1.181(30.0)	1.110(28.2) 1.091(27.7)	1.147(29.1)	M32 X 1.0-6g	.092(2.3)	.106(2.7)
F	19	1.948(49.5) 1.925(48.9)	1.813(46.1)	1.316(33.4) 1.306(33.2)	1.236(31.4) 1.220(31.0)	1.273(32.3)	M35 X 1.0-6g	.092(2.3)	.137(3.5)
G	21	2.074(52.7) 2.051(52.1)	1.939(49.3)	1.441(36.6) 1.431(36.3)	1.358(34.5) 1.342(34.1)	1.399(35.5)	M38 X 1.0-6g	.092(2.3)	.137(3.5)
H	23	2.200(55.9) 2.177(55.3)	2.061(52.3)	1.565(39.8) 1.556(39.5)	1.484(37.7) 1.468(37.3)	1.525(38.7)	M41 X 1.0-6g	.092(2.3)	.137(3.5)
J	25	2.326(59.1) 2.299(58.4)	2.187(55.5)	1.692(43.0) 1.681(42.7)	1.610(40.9) 1.594(40.5)	1.647(41.8)	M44 X 1.0-6g	.092(2.3)	.137(3.5)

SHELL SIZE CODE	J DIA ±.005 (0.1)	K ±.005 (0.1)
B	.825 (20.96)	.771 (19.59)
C	1.010 (25.65)	.955 (24.26)
D	1.135 (28.83)	1.085 (27.56)
E	1.260 (32.01)	1.210 (30.73)
F	1.385 (35.18)	1.335 (33.91)
G	1.510 (38.35)	1.460 (37.08)
H	1.635 (41.53)	1.585 (40.26)
J	1.760 (44.70)	1.710 (43.43)

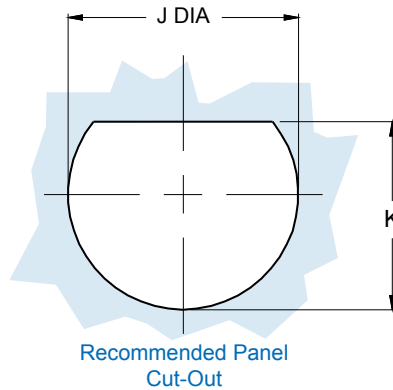

Contact Size	ø P
22D	.011 (0.28) .015 (0.38)
20	.024 (0.61) .028 (0.71)
16	.0635 (1.61) .0615 (1.56)
12	.095 (2.41) .093 (2.36)

Contact Size	Wire Gauge
22D	#22 - #28
20	#20 - #24
16	#16 - #20
12	#12 - #14

Designator	Required Leak Rate
-585A	1 x 10 <sup>-10</sup> cc Helium per second
-585B	1 x 10 <sup>-9</sup> cc Helium per second
-585C	1 x 10 <sup>-8</sup> cc Helium per second

Dimensions in Inches (millimeters) are subject to change without notice.



# D38999/45 Solder Mount Hermetic Receptacle MIL-DTL-38999 Series IV

## How To Order: MS

**B**

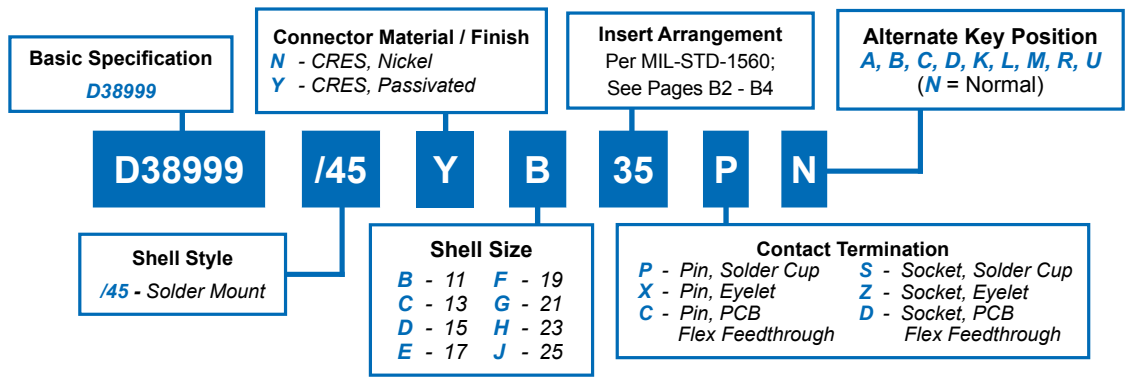

**Non-Environmental  
Rear Accessory Thread Adapter  
Available for this Receptacle  
See P/N 980-002 on Page B-90**

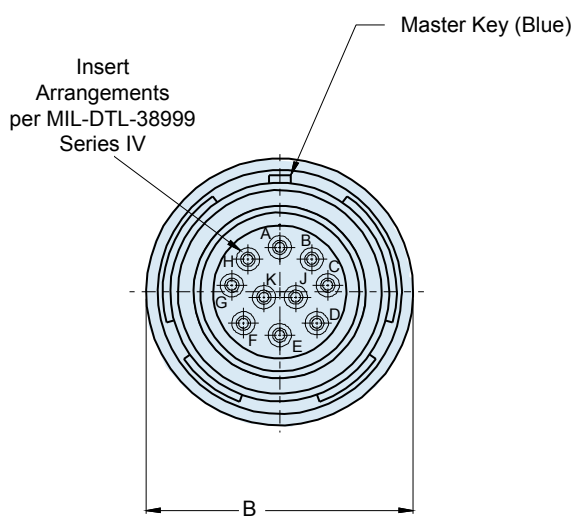
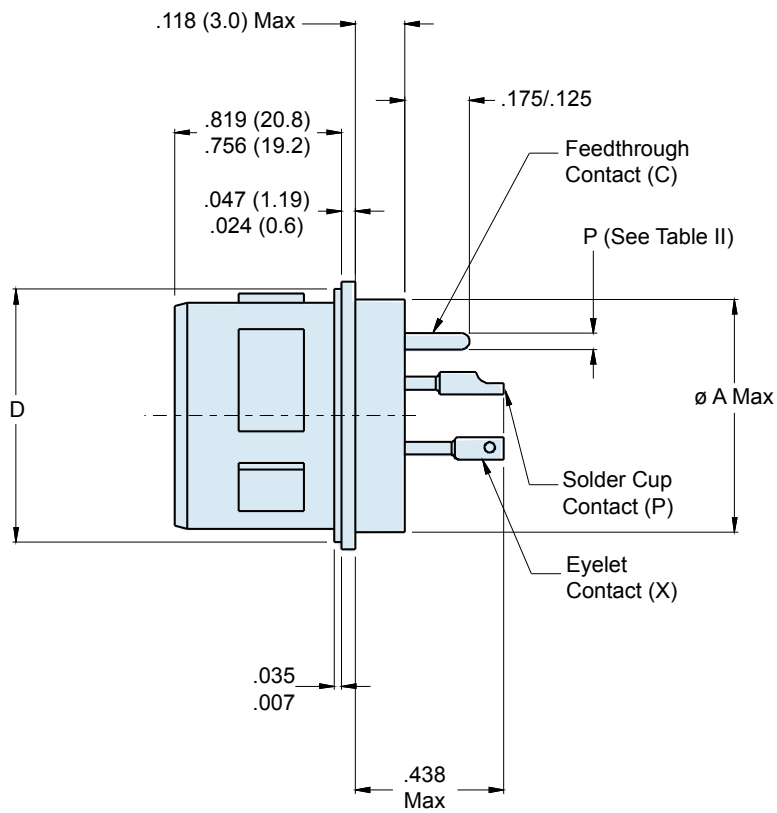

Dimensions in Inches (millimeters) are subject to change without notice.

# 234-100-H5

## Solder Mount Hermetic Receptacle

### MIL-DTL-38999 Series IV Type



### How To Order: Commercial

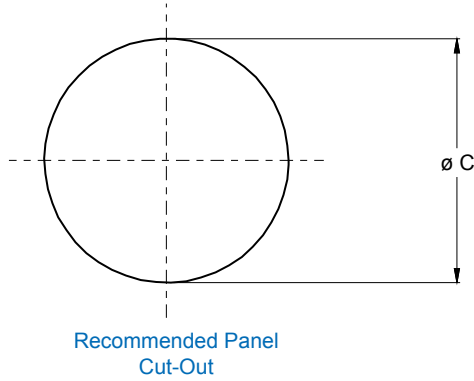
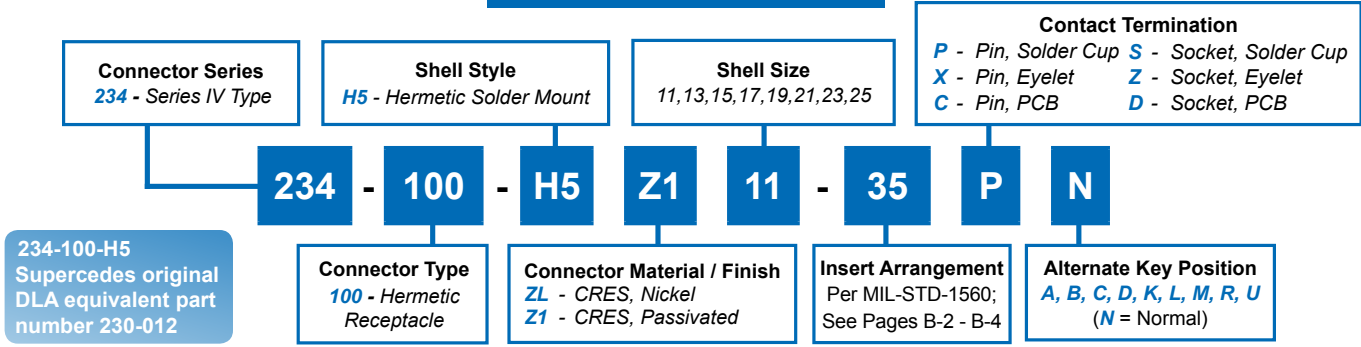

WIRE ACCOMODATION	
Contact Size	Wire Gauge
22D	#22 - #28
20	#20 - #24
16	#16 - #20
12	#12 - #14

HERMETIC LEAK RATE MOD CODES	
Designator	Required Leak Rate
-585A	1 x 10 <sup>-10</sup> cc Helium per second
-585B	1 x 10 <sup>-9</sup> cc Helium per second
-585C	1 x 10 <sup>-8</sup> cc Helium per second

TABLE I: CONNECTOR DIMENSIONS					
SHELL SIZE CODE	SHELL SIZE	ø A MAX	ø B MAX	ø C ±.005(0.1)	D
B	11	.783(19.9)	.862(21.9)	.789(20.0)	.793(20.1) .778(19.8)
C	13	.909(23.1)	.988(25.1)	.914(23.2)	.919(23.3) .904(23.0)
D	15	1.035(26.3)	1.110(28.2)	1.038(26.4)	1.044(26.5) 1.028(26.1)
E	17	1.157(29.4)	1.236(31.4)	1.164(29.6)	1.170(29.7) 1.155(29.3)
F	19	1.252(31.8)	1.331(33.8)	1.258(32.0)	1.294(32.9) 1.279(32.5)
G	21	1.378(35.0)	1.457(37.0)	1.383(35.1)	1.419(36.0) 1.404(35.7)
H	23	1.504(38.2)	1.583(40.2)	1.508(38.3)	1.544(39.2) 1.528(38.8)
J	25	1.630(41.4)	1.705(43.3)	1.643(41.7)	1.670(42.4) 1.654(42.0)

TABLE II: CONTACT SIZE	
PRINTED CIRCUIT TAIL CONFIGURATIONS CONTACT STYLE C AND D	
Contact Size	ø P
22D	.011 (0.28) .015 (0.38)
20	.024 (0.61) .028 (0.71)
16	.0635 (1.61) .0615 (1.56)
12	.095 (2.41) .093 (2.36)

Dimensions in Inches (millimeters) are subject to change without notice.





# D38999/48

## Weld Mount Hermetic Receptacle

### MIL-DTL-38999 Series IV

#### How To Order: *MS*

B

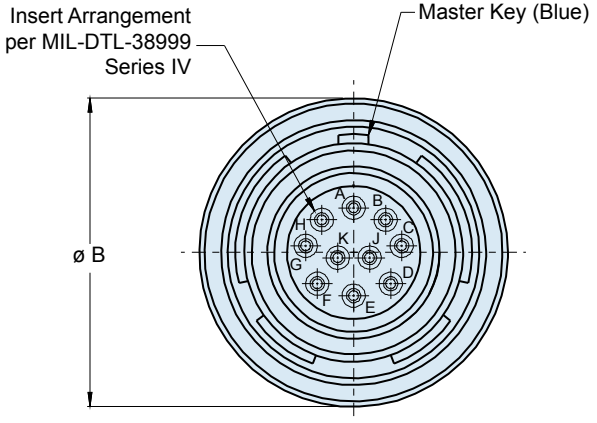
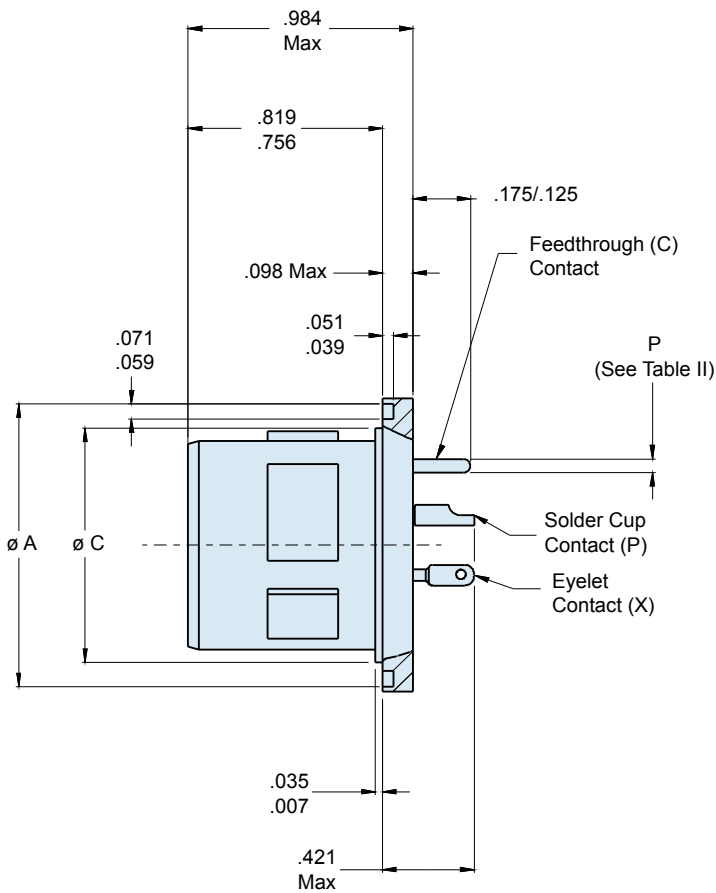
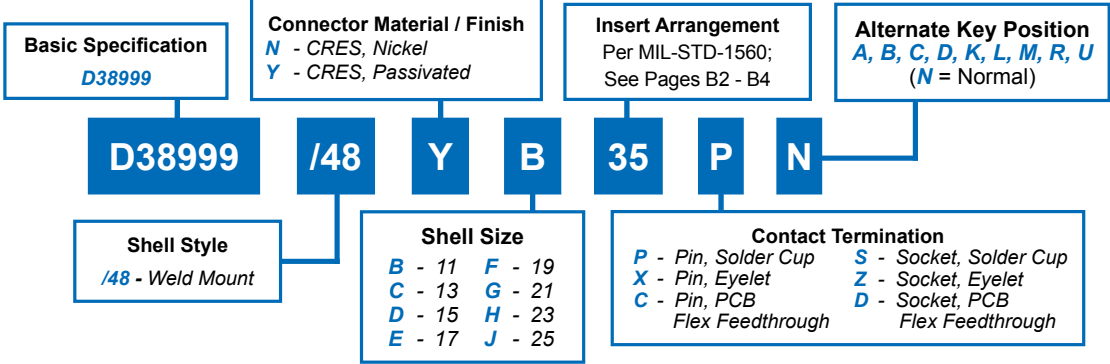

Consult Factory for Recommended Panel Cutout Dimensions

Dimensions in Inches (millimeters) are subject to change without notice.

# 234-100-H8

## Weld Mount Hermetic Receptacle

### MIL-DTL-38999 Series IV Type



### How To Order: Commercial

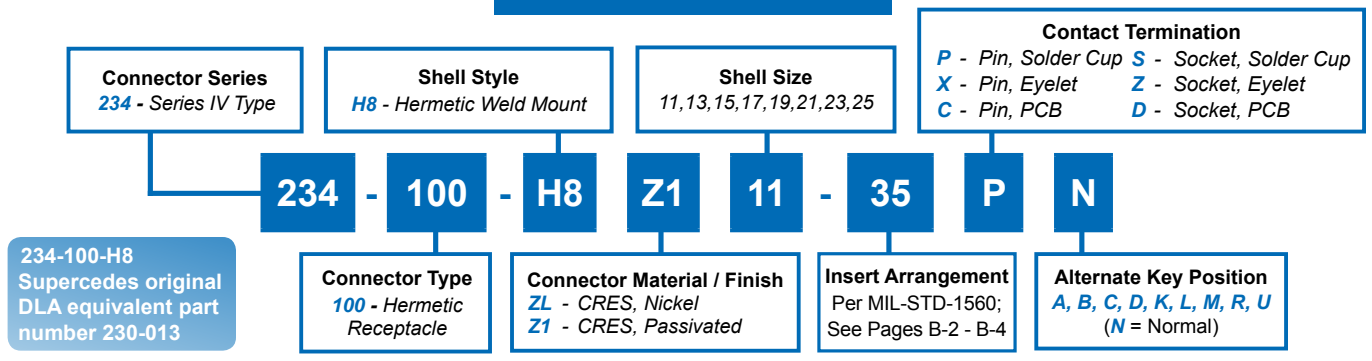

HERMETIC LEAK RATE MOD CODES	
Designator	Required Leak Rate
-585A	1 x 10 <sup>-10</sup> cc Helium per second
-585B	1 x 10 <sup>-9</sup> cc Helium per second
-585C	1 x 10 <sup>-8</sup> cc Helium per second

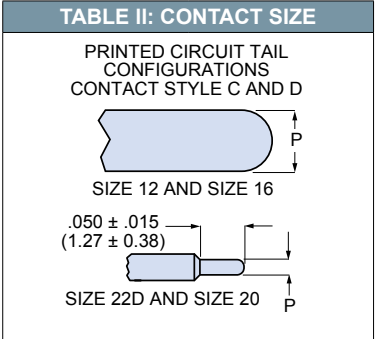

Contact Size	ø P
22D	.011 (0.28) .015 (0.38)
20	.024 (0.61) .028 (0.71)
16	.0635 (1.61) .0615 (1.56)
12	.095 (2.41) .093 (2.36)

SHELL SIZE CODE	SHELL SIZE	ø A	ø B	ø C
B	11	1.035 (26.3) 1.024 (26.0)	1.106 (28.1) 1.094 (27.8)	.793 (20.1) .778 (19.8)
C	13	1.161 (29.5) 1.150 (29.2)	1.232 (31.3) 1.220 (31.0)	.919 (23.3) .904 (23.0)
D	15	1.287 (32.7) 1.276 (32.4)	1.358 (34.5) 1.346 (34.2)	1.044 (26.5) 1.029 (26.1)
E	17	1.374 (34.9) 1.362 (34.6)	1.445 (36.7) 1.433 (36.4)	1.170 (29.7) 1.155 (29.3)
F	19	1.520 (38.6) 1.508 (38.3)	1.591 (40.4) 1.579 (40.1)	1.294 (32.9) 1.279 (32.5)
G	21	1.661 (42.2) 1.650 (41.9)	1.732 (44.0) 1.720 (43.7)	1.419 (36.0) 1.404 (35.7)
H	23	1.827 (46.4) 1.815 (46.1)	1.898 (48.2) 1.886 (47.4)	1.544 (39.2) 1.529 (38.8)
J	25	1.913 (48.6) 1.902 (48.3)	1.984 (50.4) 1.972 (50.1)	1.669 (42.4) 1.654 (42.0)

Contact Size	Wire Gauge
22D	#22 - #28
20	#20 - #24
16	#16 - #20
12	#12 - #14

Dimensions in Inches (millimeters) are subject to change without notice.



**980-002**  
**Non-Environmental Rear Accessory Thread Adapter**  
for MIL-DTL-38999/23 and /43

**B**

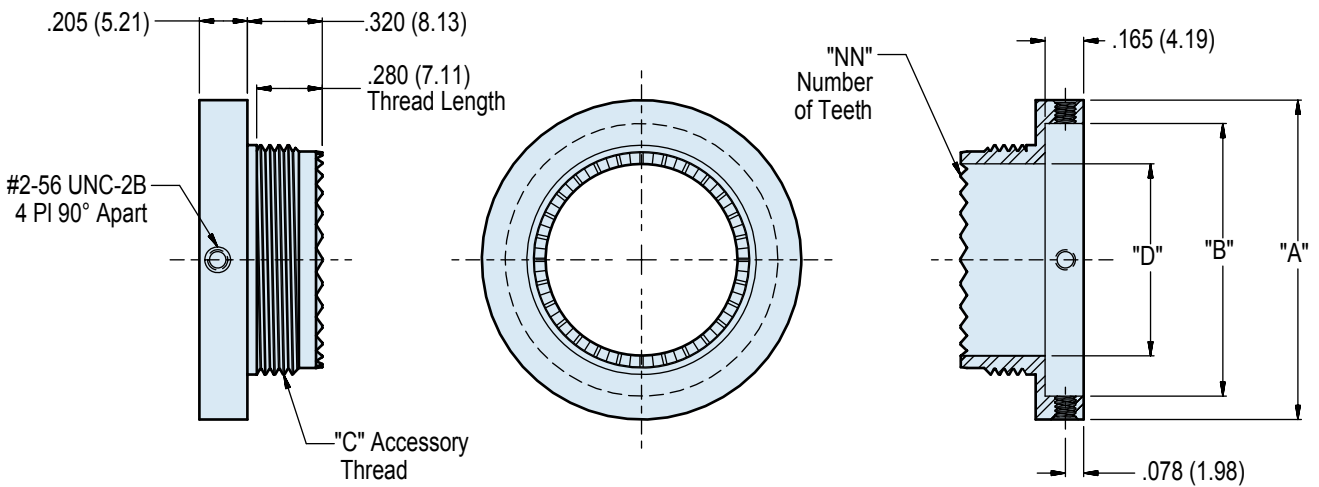
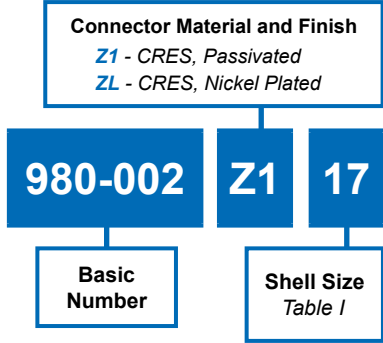

Dimensions in Inches (millimeters) are subject to change without notice.

**980-002**  
**Non-Environmental Rear Accessory Thread Adapter**  
**for MIL-DTL-38999/23 and /43**



MIL-DTL-38999  
Hermetic Connectors

B

TABLE I: CONNECTOR DIMENSIONS					
SHELL SIZE	A DIA	B DIA	C 1.0-6g 0.100R	D DIA MAX	NN TEETH
9	0.860 (21.84)	.662 (18.81) .656 (16.66)	M12	.346 (8.86)	12
11	0.985 (25.02)	.788 (20.02) .782 (19.86)	M15	.475 (12.07)	16
13	1.115 (28.32)	.917 (23.29) .911 (23.14)	M18	.589 (14.96)	20
15	1.240 (31.50)	1.042 (26.47) 1.037 (26.34)	M22	.714 (18.14)	24
17	1.360 (34.54)	1.165 (29.59) 1.159 (29.44)	M25	.839 (21.31)	28
19	1.488 (37.80)	1.291 (32.79) 1.285 (32.64)	M28	.945 (24.00)	32
21	1.615 (41.02)	1.418 (36.02) 1.412 (35.86)	M31	1.070 (27.18)	36
23	1.740 (44.20)	1.543 (39.19) 1.537 (39.04)	M34	1.194 (30.33)	40
25	1.862 (47.29)	1.665 (42.29) 1.659 (42.14)	M37	1.320 (33.53)	44

APPLICATION NOTES
<ol style="list-style-type: none"> <li>1. Assembly identified with manufacturer's name and PN, space permitting.</li> <li>2. Material/Finish:                      Adapter—300 Series CRES/passivate                      or 300 Series CRES/nickel plate                      Set Screws—18-8 CRES/None</li> <li>3. Glenair 980-002 is designed to adapt MIL-DTL-38999/23 or /43 jam-nut hermetic receptacles to use threaded rear backshells per specification.</li> </ol>

Dimensions in Inches (millimeters) are subject to change without notice.

SERIES 80

# MIGHTY MOUSE

*Hermetic Connectors with Durable  
Glass-to-Metal Sealing*



The Series 80 Connector was originally developed as a smaller and lighter alternative to D38999 connectors for aerospace applications such as Attack Helicopters and Unmanned Aerial Vehicles. Today, the Series 80 Mighty Mouse serves in dozens of safety-critical defense, medical, industrial and geo-physical applications. Glenair offers hermetic versions of this popular connector series with  $1 \times 10^{-7}$  cc/helium per second leakage rate, stainless steel shells with vitreous glass sealing, standard material options plus Titanium and Inconel® versions, available space grade special screening, plus same-day delivery on most common shell sizes and layouts.



**G**lenair®

Glenair, Inc.  
1211 Air Way  
Glendale, CA  
91201-2497  
818-247-6000  
sales@glenair.com  
www.glenair.com

# Series 80 Mighty Mouse Hermetic Connectors



## Series 800 Mighty Mouse Hermetic Connectors

**Mighty Mouse Hermetic Connectors** are supplied in six mating styles, including a triple-start threaded version, a push-pull quick-disconnect version and rugged bayonet-lock. All the connectors in the Series 80 family are available in hermetic versions with PC tail or solder cup terminations.

Made of stainless steel with a glass seal, Mighty Mouse hermetics are 100% tested to meet  $1 \times 10^{-7}$  cc/second helium leakage and an open face pressure rating of 1000 PSI.

Quick Selection Guide		
Part Number	Description	Page
	Series 800 Mighty Mouse Product Selection Guide	C-2
	Series 800 Mighty Mouse Contact Arrangements	C-4
	Series 800 Mighty Mouse Straight PCB Footprints	C-10
	Series 800 Mighty Mouse Recommended Torque Values	C-39
	Series 800 Mighty Mouse Flange Gaskets 809-108	C-40
	Glenair Hermetic Connector Products Special Leak Rate Mod Codes	C-43
<b>800-013</b>	Series 800 UN Mating Thread How to Order Information	C-44
<b>800-013-02 and 800-013-03</b>	Square Flange Mount Connectors	C-46
<b>800-013-07</b>	Jam Nut Mount Connector	C-47
<b>801-012</b>	Series 801 Double Start Mating Thread How to Order Information	C-48
<b>801-012-02</b>	Square Flange and Solder Mount Connector	C-49
<b>801-012-03</b>	Solder Mount Connector	C-50
<b>801-012-07</b>	Jam Nut Mount Connector	C-51
<b>801-012-13</b>	Weld Mount Connector	C-52
<b>801-059</b>	Quick Coupling Connector with Co-Ax Pins Ordering Information	C-53
<b>801-059-02</b>	Flange Mount Quick Coupling Connector with Co-Ax Pins	C-54
<b>801-059-03</b>	Solder Mount Quick Coupling Connector with Co-Ax Pins	C-55
<b>801-059-07</b>	Jam Nut Mount Quick Coupling Connector with Co-Ax Pins	C-56
<b>802-013</b>	Series 802 "AquaMouse" How to Order Information	C-57
<b>802-013-00</b>	Front Mount Jam Nut Receptacle	C-58
<b>802-013-02</b>	Square Flange Mount Receptacle	C-59
<b>802-013-03</b>	Weld Mount Receptacle	C-60
<b>802-013-07</b>	Rear Mount Jam Nut Receptacle	C-61
<b>802-040</b>	Series 802 "Aqua Mouse" Connector Ordering Information	C-62
<b>802-040-00</b>	Front Panel Jam Nut Mount Connector, Coax Contacts	C-63
<b>802-040-02</b>	Front Panel Square Flange Mount Connector, Coax Contacts	C-64
<b>802-040-03</b>	Weld Mount Connector, Coax Contacts	C-65
<b>802-040-07</b>	Rear Panel Jam Nut Mount Connector, Coax Contacts	C-66
<b>803-006</b>	Series 803 1/4 Turn Bayonet How to Order Information	C-67
<b>803-006-02 and 803-006-07</b>	Flange Mount and Jam Nut Mount Connectors	C-68
<b>804-006</b>	Series 804 Push-Pull How to Order Information	C-69
<b>804-006-00</b>	Front Panel Jam Nut Mount Receptacle	C-70
<b>804-006-07</b>	Rear Panel Jam Nut Mount Receptacle	C-71
<b>805-006</b>	Series 805 Triple Start Mating Thread How to Order Information	C-72
<b>805-006-02</b>	Square Flange Mount Connector	C-73
<b>805-006-03</b>	Solder Mount Connector	C-74
<b>805-006-07</b>	Jam Nut Mount Connector	C-75
<b>805-006-13</b>	Front Panel Weld Mount Connector	C-76

Hermetic Finishes			
Plating Code	Material	Finish	Specification
Z1	Stainless Steel	Passivate	AMS-QQ-P-35
ZL	Stainless Steel	Electrodeposited Nickel	SAE-AMS-QQ-N-290, Class 2

Hermetic Materials	
Shell, Barrel Coupling and Jam Nut (Hermetic)	Stainless steel per AMS-QQ-S-763
Front and Rear Insulators	Glass-filled liquid crystal polymer (LCP) in accordance with MIL-M-24519, Type GLP-30F
Grommet, Peripheral Seal and Interfacial Seal	Blended elastomer, 30% silicone per ZZ-R-765, 70% fluorosilicone per MIL-R-25988
Hermetic Insert	Vitreous glass
Contacts	Nickel-iron alloy per ASTM F30 (Alloy 52), 50 microinches gold plated per ASTM B488 Type 3 Code C Class 1, 27 over nickel plate per QQ-N-290 Class 2, 50-100 microinches
Adhesives	Silicone and epoxy
Potting Compound	Epoxy





## Series 80 Mighty Mouse Product Selection Guide

The Series 80 Mighty Mouse Connector is designed for high-reliability commercial and aerospace/defense interconnect applications that require both robust environmental/EMI performance and reduced size and weight. The Series 80 Mighty Mouse Connector offers comparable performance to MIL-DTL-38999 Series interconnects with up to 71% weight and 52% size savings for similar contact layouts. Six versions available, offer a range of styles and features suitable for various applications. Please reference document [809-009](#) for the complete performance specifications.

### Series 800

### Series 801

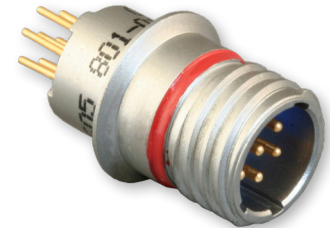
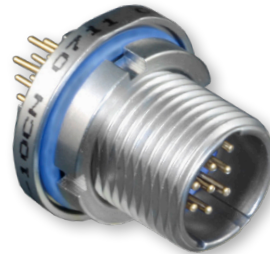

Description	Original Mighty Mouse with UNF Threads	Double-Start ACME Thread
Notes	A general purpose connector for high-speed Ethernet switches, tactical equipment and instrumentation.	More rugged keys and threads compared to Series 800. Faster mating, slightly larger than Series 800.
Number of Contacts	1 to 37	1 to 130
Coupling	Threaded Coupling with 4 ½ Turns to Full Mate	Threaded Coupling with 1 ½ Turns to Full Mate
EMI Shielding	Good	Good
Vibration and Shock	37 g's Random Vibration; 300 g's Shock	37 g's Random Vibration; 300 g's Shock
Mating Cycles	500 Cycles	500 Cycles
Electrical Performance	#8: 33 AMP, 500 VAC #12: 17 AMP, 500 VAC #16: 10 AMP, 500 VAC #20: 5 AMP, 500 VAC #23: 3 AMP, 500 VAC	#8: 33 AMP, 500 VAC #12: 17 AMP, 500 VAC #16: 10 AMP, 500 VAC #20: 5 AMP, 500 VAC #23: 3 AMP, 500 VAC
Proven Performance Applications	Commercial air frame sensors; UAV telemetry; Tactical computers; field radios	Military air frame; Dismounted soldier; Tactical ground weaponry; Avionic (FLIR) systems
Temperature Rating	-65°C to +200°C hermetic	
Hermeticity	1 X10 <sup>-7</sup> cc/second maximum helium leak rate	

Dimensions in Inches (millimeters) are subject to change without notice.

Series 80 Mighty Mouse  
Product Selection Guide



Series 802	Series 803	Series 804	Series 805
------------	------------	------------	------------



"Aqua Mouse" 3500 PSI	Bayonet	Push-Pull	Triple-Start ACME Thread
Rugged stainless steel, resists chemicals. For geophysical and underwater applications.	Quick-mating, light duty, general purpose. Not rated for immersion. 50 milliohms shell-to-shell resistance.	Breakaway connector for headsets and tactical equipment. Gold-plated spring for long mating life and superior EMI shielding.	"Clicker" ratchet mechanism and ground spring for military airframes and avionics boxes. Fast-mating, D38999 equivalent.
1 to 130	1 to 55	1 to 55	1 to 130
Threaded Coupling with UN Threads	Push-to-Mate, ¼ Turn to Lock	Quick-Disconnect	One Full Turn for Full Mate
Good	Fair	Very Good	Excellent
37 g's Random Vibration; 300 g's Shock	37 g's Random Vibration; 300 g's Shock	37 g's Random Vibration; 300 g's Shock	37 g's Random Vibration; 300 g's Shock
500 Cycles	500 Cycles	500 Cycles	500 Cycles
#8: 33 AMP, 500 VAC #12: 17 AMP, 500 VAC #16: 10 AMP, 500 VAC #20: 5 AMP, 500 VAC #23: 3 AMP, 500 VAC	#8: 33 AMP, 500 VAC #12: 17 AMP, 500 VAC #16: 10 AMP, 500 VAC #20: 5 AMP, 500 VAC #23: 3 AMP, 500 VAC	#8: 33 AMP, 500 VAC #12: 17 AMP, 500 VAC #16: 10 AMP, 500 VAC #20: 5 AMP, 500 VAC #23: 3 AMP, 500 VAC	#8: 33 AMP, 500 VAC #12: 17 AMP, 500 VAC #16: 10 AMP, 500 VAC #20: 5 AMP, 500 VAC #23: 3 AMP, 500 VAC
Pipe line inspection equipment; Well logging; Amphibious vehicles; Unmanned submersibles	Soldier system radios; Autosport diagnostics; Airborne surveillance; Communication systems	Helmet breakaway connector; QDC battery; Missile applications; Weapon interconnects	Autosport; Military air frame; Joint Strike Fighter

-65°C to +200°C Hermetic

1 X10<sup>-7</sup> cc/second maximum helium leak rate

Dimensions in Inches (millimeters) are subject to change without notice.



## Series 80 Mighty Mouse Contact Arrangements

Series 80 Mighty Mouse Contact Arrangements

Contact Size	Contact Quantity						Contact Arrangement*					
	#23	#20	#20HD	#16	#12	#8	Series 800	Series 801	Series 802	Series 803	Series 804	Series 805
Size #23 Contacts 3 Amp Max. Current #22-#28 AWG  750 VAC DWV	3						5-3	5-3	5-3	5-3	5-3	N/A
	4						6-4	6-4	6-4	6-4	6-4	8-4
	6						6-6	6-6	6-6	6-6	6-6	8-6
	7						6-7	6-7	6-7	6-7	6-7	8-7
	10						7-10	7-10	7-10	7-10	7-10	9-10
	13						8-13	8-13	8-13	8-13	8-13	10-13
	19						9-19	9-19	9-19	9-19	9-19	11-19
	26						10-26	10-26	10-26	10-26	10-26	12-26
	31						N/A	11-31	N/A	11-31	11-31	13-31
	37						12-37	13-37	12-37	12-37	12-37	15-37
	55						N/A	16-55	14-55	14-55	14-55	18-55
	85						N/A	17-85	15-85	N/A	N/A	19-85
	100						N/A	19-100	19-100	N/A	N/A	21-100
130						N/A	21-130	21-130	N/A	N/A	23-130	
Size #20HD Contacts 5 Amp Max. Current #20- #24 AWG  1000 VAC DWV			3				6-23	6-23	6-23	6-23	6-23	8-23
			5				7-25	7-25	7-25	7-25	7-25	9-25
			8				8-28	8-28	8-28	8-28	8-28	10-28
			10				9-210	9-210	9-210	9-210	9-210	11-210
			20				12-220	13-220	12-220	12-220	12-220	15-220
			35				N/A	16-235	14-235	14-235	14-235	18-235
			41				N/A	17-241	15-241	N/A	N/A	19-241
			55				N/A	19-255	19-255	N/A	N/A	21-255
Size #16 Contacts 10 Amp Max. Current #16-#20 AWG  1800 VAC DWV				1			6-1	6-1	6-1	6-1	6-1	8-1
				2			8-2	8-2	8-2	8-2	8-2	10-2
				4			9-4	9-4	9-4	9-4	9-4	11-4
				5			10-5	10-5	10-5	10-5	10-5	12-5
				7			12-7	13-7	12-7	12-7	12-7	15-7
				12			N/A	16-12	14-12	14-12	14-12	18-12
				14			N/A	17-14	15-14	N/A	N/A	19-14
				19			N/A	19-19	19-19	N/A	N/A	21-19
Size #12 Contacts 17 Amp Max. Current #12-#14 AWG  1800 VAC DWV					1		7-1	7-1	7-1	7-1	7-1	9-1
					2		10-2	10-2	10-2	10-2	10-2	12-2
					2		12-2	13-2	12-2	12-2	12-2	15-2
					3		12-3	13-3	12-3	12-3	12-3	15-3
					5		N/A	16-5	14-5	14-5	14-5	18-5
					7		N/A	17-7	15-7	N/A	N/A	19-7
Size #8 Contacts 33 Amp Max. Current #8 AWG  1800 VAC DWV						1	8-1	8-1	8-1	8-1	8-1	10-1
						2	N/A	16-2	14-2	14-2	14-2	18-2
						3	N/A	17-3	15-3	N/A	N/A	19-3
						4	N/A	19-4	19-4	N/A	N/A	21-4
						5	N/A	21-5	21-5	N/A	N/A	23-5
Combo Arrangements	12				1		10-200	10-200	10-200	10-200	10-200	12-200
	4				2		10-201	10-201	10-201	10-201	10-201	12-201
	6				2		12-200	13-200	12-200	12-200	12-200	15-200
	10				2		12-201	13-201	12-201	12-201	12-201	15-201
	4			2			9-200	9-200	9-200	9-200	9-200	11-200
	8			2			10-202	10-202	10-202	10-202	10-202	12-202
	4	2					8-200	8-200	8-200	8-200	8-200	10-200
	8	2					9-201	9-201	9-201	9-201	9-201	11-201
	20			2			12-202	13-202	12-202	12-202	12-202	15-202
	12			4			12-203	13-203	12-203	12-203	12-203	15-203
	40			2			N/A	16-204	14-204	14-204	14-204	18-204
	32			4			N/A	16-205	14-205	14-205	14-205	18-205
	40			4			N/A	17-203	15-203	N/A	N/A	19-203
	12				2		12-204	13-204	12-204	12-204	12-204	15-204
	4				4		12-205	13-205	12-205	12-205	12-205	15-205
	34				2		N/A	16-206	14-206	14-206	14-206	18-206
	20				4		N/A	16-207	14-207	14-207	14-207	18-207
	28				4		N/A	17-204	15-204	N/A	N/A	19-204
32					1	N/A	16-208	14-208	14-208	14-208	18-208	
40					1	N/A	17-205	15-205	N/A	N/A	19-205	
44					2	N/A	19-201	19-201	N/A	N/A	21-201	
12					4	N/A	19-202	19-202	N/A	N/A	21-202	
28					4	N/A	21-200	21-200	N/A	N/A	23-200	

Dimensions in Inches (millimeters) are subject to change without notice.

# Series 80 Mighty Mouse Contact Arrangements Mating Face View of Pin Connector (Socket Connector Numbers are Reversed)



Series 80  
Mighty Mouse

**Contact Legend**  
 #23 ○ #16 ●  
 #20HD ⊕ #12 ⊕  
 #20 ● #8 ●



Series 800, 801, 802, 803, 804	5-3	6-1	6-23	6-4	6-6	6-7
Series 805	N/A	8-1	8-23	8-4	8-6	8-7
No. of Contacts	3	1	3	4	6	7
Contact Size	#23	#16	#20HD	#23	#23	#23
DWV Voltage (VAC)	750	1800	1000	750	750	750
Current Rating (Amps)	3	10	5	3	3	3

C

**Contact Legend**  
 #23 ○ #16 ●  
 #20HD ⊕ #12 ⊕  
 #20 ● #8 ●



Series 800, 802, 803, 804	6-1	7-25	7-10	N/A	8-2	8-28
Series 801	6-1	7-25	7-10	8-1	8-2	8-28
Series 805	9-1	9-25	9-10	10-1	10-2	10-28
No. of Contacts	1	5	10	1	2	8
Contact Size	#12	#20HD	#23	#8	#16	#20HD
DWV Voltage (VAC)	1800	1000	750	1800	1800	1000
Current Rating (Amps)	17	5	3	33	10	5

**Contact Legend**  
 #23 ○ #16 ●  
 #20HD ⊕ #12 ⊕  
 #20 ● #8 ●

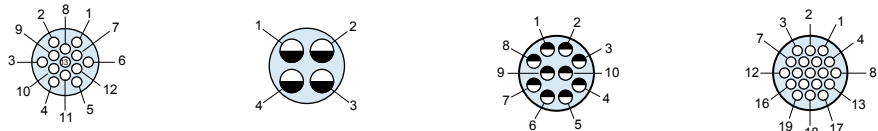

Series 800, 801, 802, 803, 804	8-13	9-4	9-210	9-19
Series 805	10-13	11-4	11-210	11-19
No. of Contacts	13	4	10	19
Contact Size	#23	#16	#20HD	#23
DWV Voltage (VAC)	750	1800	1000	750
Current Rating (Amps)	3	10	5	3

**Contact Legend**  
 #23 ○ #16 ●  
 #20HD ⊕ #12 ⊕  
 #20 ● #8 ●

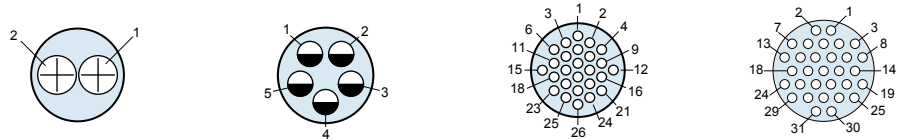

Series 800, 801, 802, 803, 804	10-2	10-5	10-26	11-31
Series 805	12-2	12-5	12-26	13-31
No. of Contacts	2	5	26	31
Contact Size	#12	#16	#23	#23
DWV Voltage (VAC)	1800	1800	750	750
Current Rating (Amps)	17	10	3	3

2. Only available for 801 and 804

Dimensions in Inches (millimeters) are subject to change without notice.

© 2013 Glenair, Inc.

U.S. CAGE Code 06324

Printed in U.S.A.



# Series 80 Mighty Mouse Contact Arrangements Mating Face View of Pin Connector (Socket Connector Numbers are Reversed)

C

**Contact Legend**

- #23 ○ #16 ●
- #20HD ◐ #12 ⊕
- #20 ● #8 ●

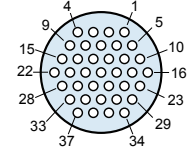
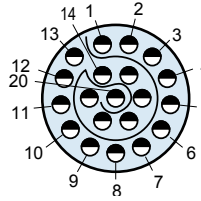
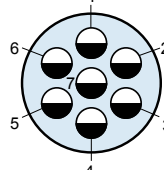
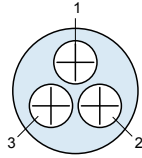
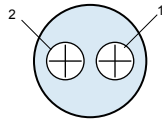

Series 800, 802, 803, 804	12-2	12-3	12-7	12-220	12-37
Series 801	13-2	13-3	13-7	13-220	13-37
Series 805	15-2	15-3	15-7	15-220	15-37
No. of Contacts	2	3	7	20	37
Contact Size	#12	#12	#16	#20HD	#23
DWV Voltage (VAC)	1800	1800	1800	1000	750
Current Rating (Amps)	17	17	10	5	3

**Contact Legend**

- #23 ○ #16 ●
- #20HD ◐ #12 ⊕
- #20 ● #8 ●

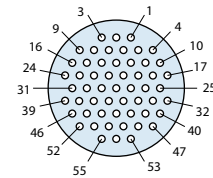
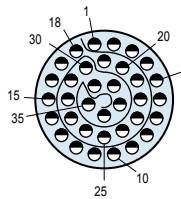
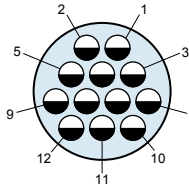
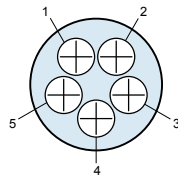
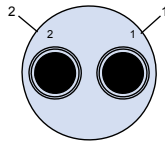

Series 802, 803, 804	N/A	14-5	14-12	14-235	14-55
Series 801	16-2	16-5	16-12	16-235	16-55
Series 805	18-2	18-5	18-12	18-235	18-55
No. of Contacts	2	5	12	35	55
Contact Size	#8	#12	#16	#20HD	#23
DWV Voltage (VAC)	1800	1800	1800	1000	750
Current Rating (Amps)	33	17	10	5	3

**Contact Legend**

- #23 ○ #16 ●
- #20HD ◐ #12 ⊕
- #20 ● #8 ●

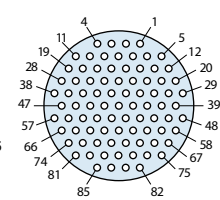
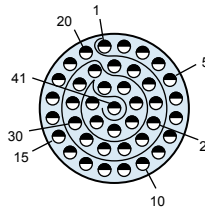
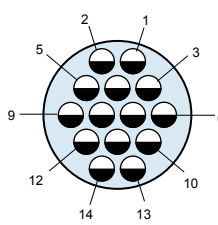
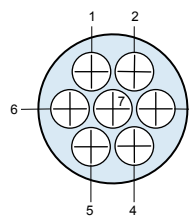
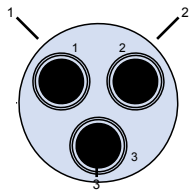

Series 802	N/A	15-7	15-14	15-241	15-85
Series 801	17-3	17-7	17-14	17-241	17-85
Series 805	19-3	19-7	19-14	19-241	19-85
No. of Contacts	3	7	14	41	85
Contact Size	#8	#12	#16	#20HD	#23
DWV Voltage (VAC)	1800	1800	1800	1000	750
Current Rating (Amps)	33	17	10	5	3

Dimensions in Inches (millimeters) are subject to change without notice.

# Series 80 Mighty Mouse Contact Arrangements Mating Face View of Pin Connector (Socket Connector Numbers are Reversed)



Series 80  
Mighty Mouse

C

### Contact Legend

- #23 ○ #16 ●
- #20HD ⊕ #12 ⊕
- #20 ● #8 ●

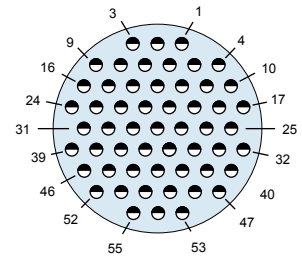
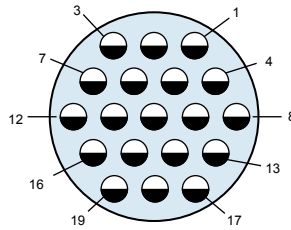
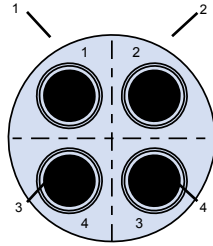

Series 801, 802	19-4 <sup>1</sup>	19-19 <sup>1</sup>	19-255 <sup>1</sup>
Series 805	21-4	21-19	21-255
No. of Contacts	4	19	55
Contact Size	#8	#16	#20HD
DWV Voltage (VAC)	1800	1800	1000
Current Rating (Amps)	33	10	5

### Contact Legend

- #23 ○ #16 ●
- #20HD ⊕ #12 ⊕
- #20 ● #8 ●

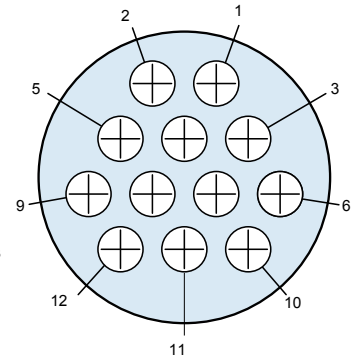
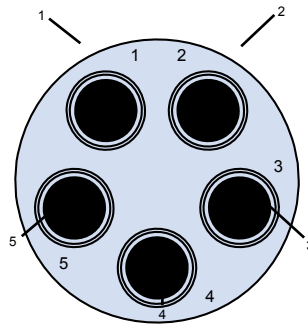
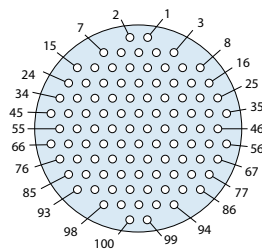

Series 801, 802	19-100 <sup>1</sup>	21-5 <sup>1</sup>	21-12
Series 805	21-100	23-5	23-12
No. of Contacts	100	5	12
Contact Size	#23	#8	#12
DWV Voltage (VAC)	750	1800	1800
Current Rating (Amps)	3		

### Contact Legend

- #23 ○ #16 ●
- #20HD ⊕ #12 ⊕
- #20 ● #8 ●

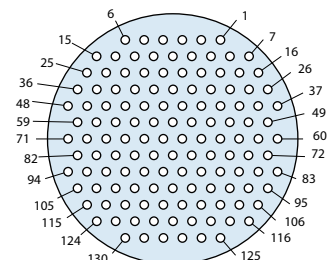
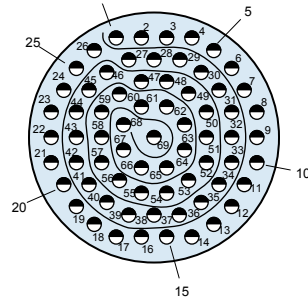
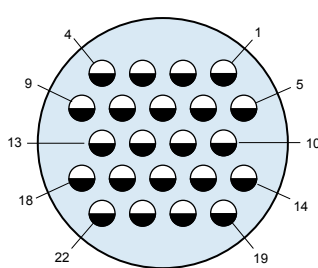

Series 801, 802	21-22	21-269	21-130
Series 805	23-22	23-269	23-130
No. of Contacts	22	69	130
Contact Size	#16	#20HD	#23
DWV Voltage (VAC)	1800	1000	750
Current Rating (Amps)	10	5	3

1. Not available for Series 802

Dimensions in Inches (millimeters) are subject to change without notice.





## Series 80 Mighty Mouse Combo Contact Arrangements Mating Face View of Pin Connector (Socket Connector Numbers are Reversed)

**Contact Legend**

- #23 ○ #16 ●
- #20HD ⊕ #12 ⊕
- #20 ● #8 ●

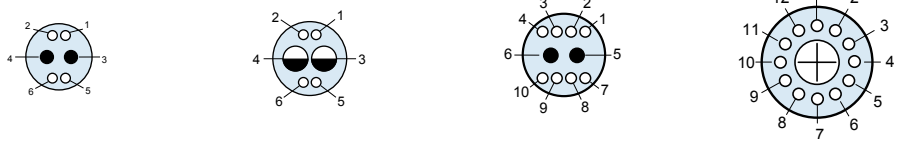

Series 800, 801, 802, 803, 804	8-200		9-200		9-201		10-200	
Series 805	10-200		11-200		11-201		12-200	
No. of Contacts	2	4	2	4	2	8	1	12
Contact Size	#20	#23	#16	#23	#20	#23	#12	#23
DWV Voltage (VAC)	1000	750	1800	750	1000	750	1800	750
Current Rating (Amps)	5	3	10	3	5	3	17	3

**Contact Legend**

- #23 ○ #16 ●
- #20HD ⊕ #12 ⊕
- #20 ● #8 ●

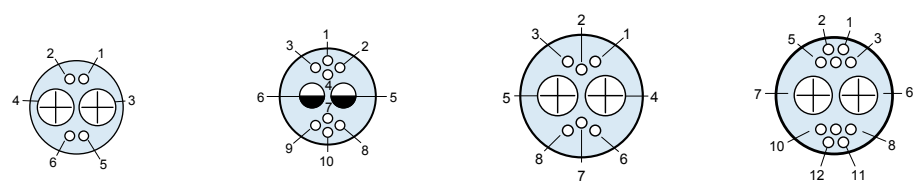

Series 800, 802, 803, 804	10-201		10-202		12-200		12-201	
Series 801	10-201		10-202		13-200		13-201	
Series 805	12-201		12-202		15-200		15-201	
No. of Contacts	2	4	2	8	2	6	2	10
Contact Size	#12	#23	#16	#23	#12	#23	#12	#23
DWV Voltage (VAC)	1800	750	1800	750	1800	750	1800	750
Current Rating (Amps)	17	3	10	3	17	3	17	3

**Contact Legend**

- #23 ○ #16 ●
- #20HD ⊕ #12 ⊕
- #20 ● #8 ●

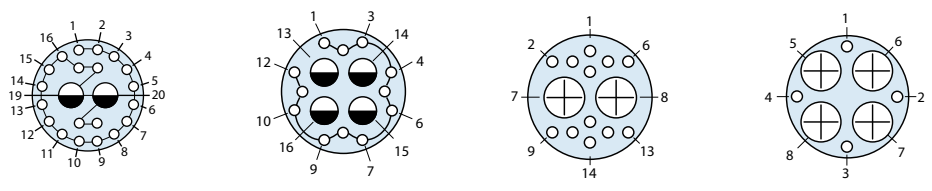

Series 800, 802, 803, 804	12-202		12-203		12-204		12-205	
Series 801	13-202		13-203		13-204		13-205	
Series 805	15-202		15-203		15-204		15-205	
No. of Contacts	2	20	4	12	2	12	4	4
Contact Size	#16	#23	#16	#23	#12	#23	#12	#23
DWV Voltage (VAC)	1800	1300	1800	1300	1800	1300	1800	1300
Current Rating (Amps)	10	3	10	3	17	3	17	3

Dimensions in Inches (millimeters) are subject to change without notice.

# Series 80 Mighty Mouse Combo Contact Arrangements Mating Face View of Pin Connector (Socket Connector Numbers are Reversed)



**Contact Legend**  
 #23 ○ #16 ⊖  
 #20HD ⊙ #12 ⊕  
 #20 ● #8 ⊗

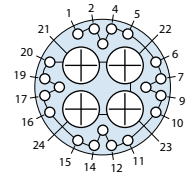
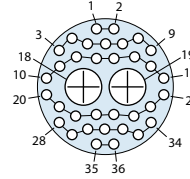
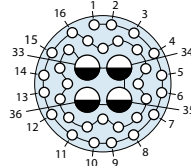
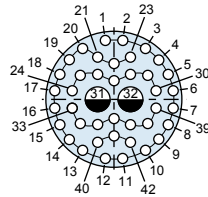

Series 802, 803, 804	14-204		14-205		14-206		14-207	
Series 801	16-204		16-205		16-206		16-207	
Series 805	18-204		18-205		18-206		18-207	
No. of Contacts	2	40	4	32	2	34	4	20
Contact Size	#16	#23	#16	#23	#12	#23	#12	#23
DWV Voltage (VAC)	1800	1300	1800	1300	1800	1300	1800	1300
Current Rating (Amps)	10	3	10	3	17	3	17	3

**Contact Legend**  
 #23 ○ #16 ⊖  
 #20HD ⊙ #12 ⊕  
 #20 ● #8 ⊗

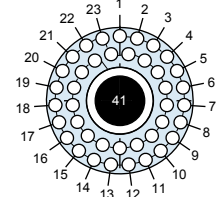
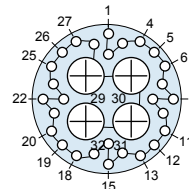
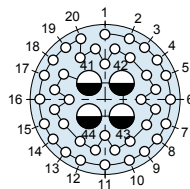
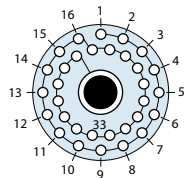

Series 802	N/A		15-203		15-204		N/A	
Series 801	16-208		17-203		17-204		17-205	
Series 805	18-208		19-203		19-204		19-205	
No. of Contacts	1	32	4	40	4	28	1	40
Contact Size	#8	#23	#16	#23	#12	#23	#8	#23
DWV Voltage (VAC)	1800	1300	1800	1300	500	1300	500	1300
Current Rating (Amps)	33	3	10	3	17	3	33	3

**Contact Legend**  
 #23 ○ #16 ⊖  
 #20HD ⊙ #12 ⊕  
 #20 ● #8 ⊗

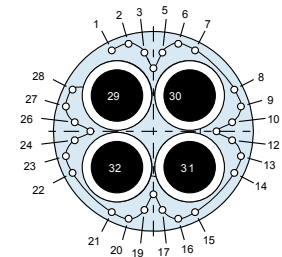
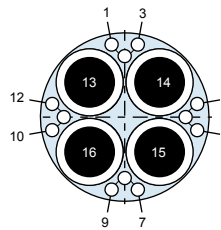
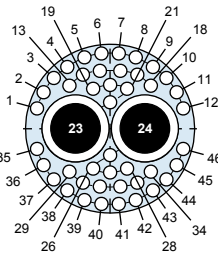

Series 801	19-201		19-202		21-200	
Series 805	21-201		21-202		23-200	
No. of Contacts	2	44	4	12	4	28
Contact Size	#8	#23	#8	#23	#8	#23
DWV Voltage (VAC)	1800	1300	1800	1300	1800	1300
Current Rating (Amps)	33	3	33	3	33	3

Dimensions in Inches (millimeters) are subject to change without notice.



Series 80 Mighty Mouse Technical Reference  
Straight PCB Footprints  
Component Mounting Side of PCB

Insert Arrangement

Pin Connector

Socket Connector

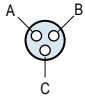

**Insert Arrangement  
5-3**

3 #23 Contacts  
.022 (0.56) Max. Dia. Tail

Series 801: **5-3**  
Series 800, 802, 803,804: **5-3**  
Series 805: **N/A**

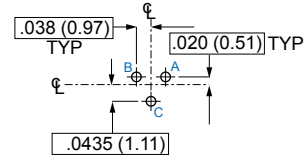
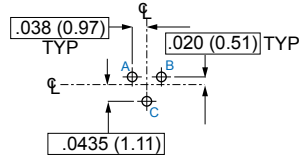

**Insert Arrangement  
6-23, 8-23**

3 #20HD Contacts  
.028 (0.56) Max. Dia. Tail

Series 801: **6-23**  
Series 800, 802, 803,804: **6-23**  
Series 805: **8-23**

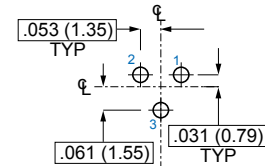
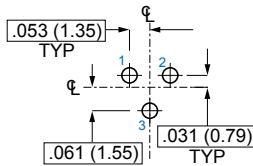

**Insert Arrangement  
6-4, 8-4**

4 #23 Contacts  
.022 (0.56) Max. Dia. Tail

Series 801: **5-3**  
Series 800, 802, 803,804: **5-3**  
Series 805: **N/A**

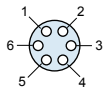
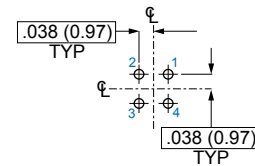
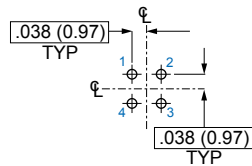

**Insert Arrangement  
6-6, 8-6**

6 #23 Contacts  
.022 (0.56) Max. Dia. Tail

Series 801: **5-3**  
Series 800, 802, 803,804: **5-3**  
Series 805: **N/A**

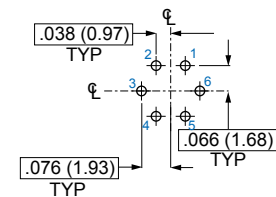
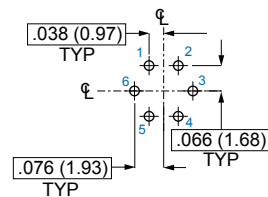

Dimensions in Inches (millimeters) are subject to change without notice.

Series 80 Mighty Mouse Technical Reference  
 Straight PCB Footprints  
 Component Mounting Side of PCB



Insert Arrangement | Pin Connector | Socket Connector

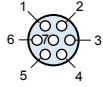

**Insert Arrangement  
 6-7, 8-7**

7 #23 Contacts  
 .022 (0.56) Max. Dia. Tail

Series 801: **6-7**  
 Series 800, 802, 803,804: **6-7**  
 Series 805: **8-7**

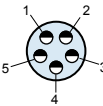
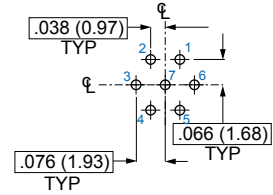
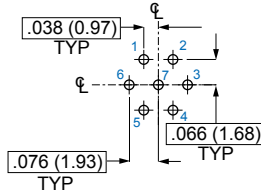

**Insert Arrangement  
 7-25, 9-25**

5 #20HD Contacts  
 .028 (0.71) Max. Dia. Tail

Series 801: **7-25**  
 Series 800, 802, 803,804: **7-25**  
 Series 805: **9-25**

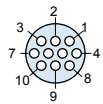
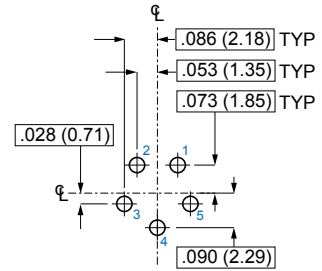
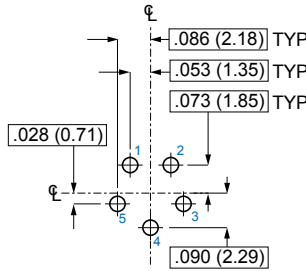

**Insert Arrangement  
 7-10, 9-10**

10 #23 Contacts  
 .022 (0.56) Max. Dia. Tail

Series 801: **7-10**  
 Series 800, 802, 803,804: **7-10**  
 Series 805: **9-10**

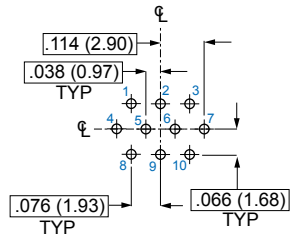
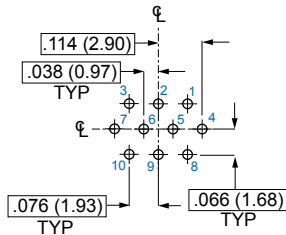

**Insert Arrangement  
 8-2, 10-2**

2 #16 Contacts  
 .064 (1.63) Max. Dia. Tail

Series 801: **8-2**  
 Series 800, 802, 803,804: **8-2**  
 Series 805: **10-2**

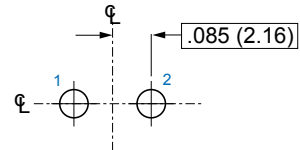
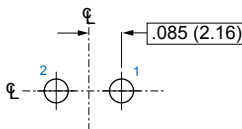

Dimensions in Inches (millimeters) are subject to change without notice.



Series 80 Mighty Mouse Technical Reference  
Straight PCB Footprints  
Component Mounting Side of PCB

Insert Arrangement

Pin Connector

Socket Connector

C

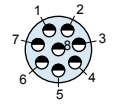

**Insert Arrangement**  
**8-28, 10-28**  
8 #20HD Contacts  
.028 (0.71) Max. Dia. Tail

Series 801: **8-28**  
Series 800, 802, 803,804: **8-28**  
Series 805: **10-28**

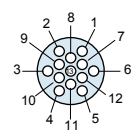
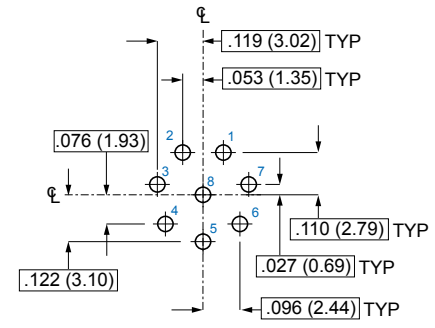
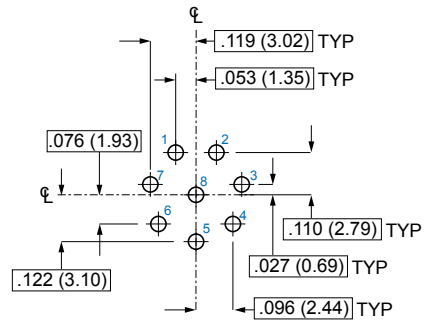

**Insert Arrangement**  
**8-13, 10-13**  
13 #23 Contacts  
.022 (0.56) Max. Dia. Tail

Series 801: **8-13**  
Series 800, 802, 803,804: **8-13**  
Series 805: **10-13**

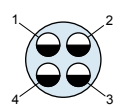
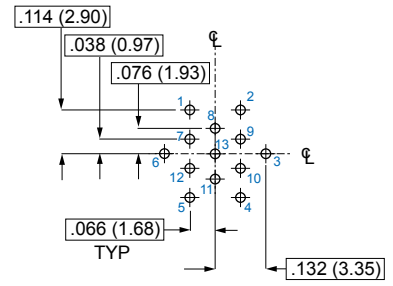
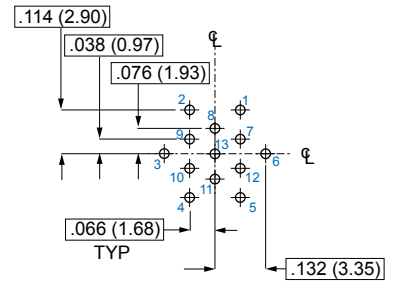

**Insert Arrangement**  
**9-4, 11-4**  
4 #16 Contacts  
.064 (1.63) Max. Dia. Tail

Series 801: **9-4**  
Series 800, 802, 803,804: **9-4**  
Series 805: **11-4**

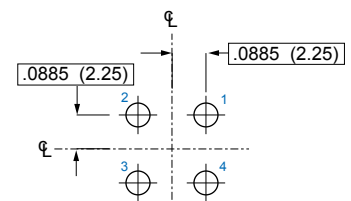
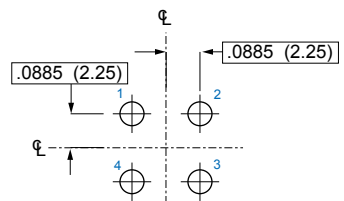

Dimensions in Inches (millimeters) are subject to change without notice.

Series 80 Mighty Mouse Technical Reference  
 Straight PCB Footprints  
 Component Mounting Side of PCB



Insert Arrangement | Pin Connector | Socket Connector

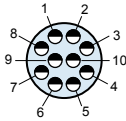

**Insert Arrangement**  
**9-210, 11-210**  
 10 #20HD Contacts  
 .028 (0.71) Max. Dia. Tail

Series 801: **9-210**  
 Series 800, 802, 803,804: **9-210**  
 Series 805: **11-210**

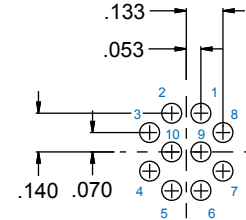
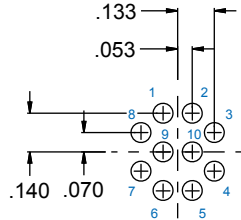

C

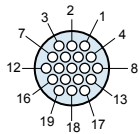

**Insert Arrangement**  
**9-19, 11-19**  
 19 #23 Contacts  
 .022 (0.56) Max. Dia. Tail

Series 801: **9-19**  
 Series 800, 802, 803,804: **9-19**  
 Series 805: **11-19**

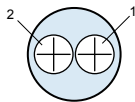
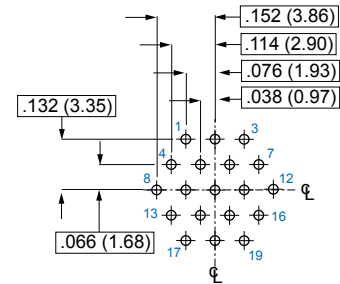
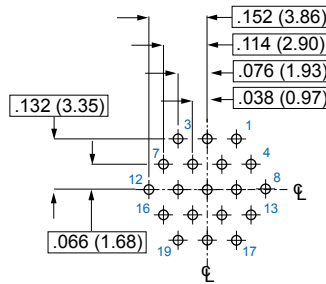

**Insert Arrangement**  
**10-2, 12-2**  
 2 #12 Contacts  
 .096 (2.44) Max Dia. Tail

Series 801: **10-2**  
 Series 800, 802, 803,804: **10-2**  
 Series 805: **12-2**

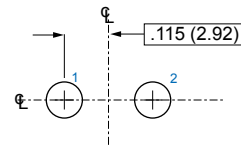
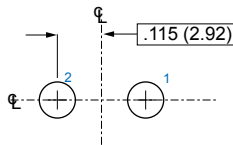

Dimensions in Inches (millimeters) are subject to change without notice.





Series 80 Mighty Mouse Technical Reference  
Straight PCB Footprints  
Component Mounting Side of PCB

Insert Arrangement

Pin Connector

Socket Connector

C

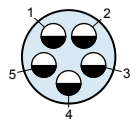

**Insert Arrangement**  
**10-5, 12-5**  
5 #16 Contacts  
.064 (1.63) Max. Dia. Tail

Series 801: **10-5**  
Series 800, 802, 803,804: **10-5**  
Series 805: **12-5**

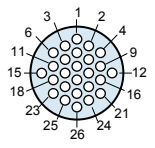
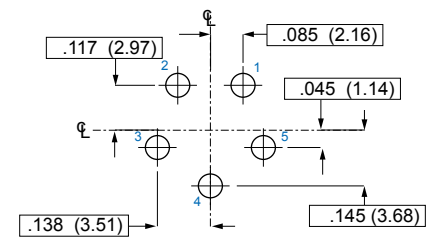
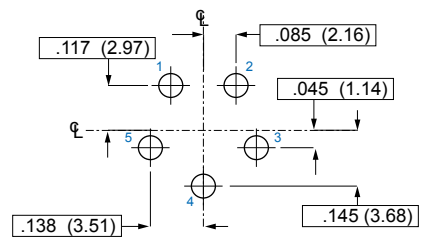

**Insert Arrangement**  
**10-26, 12-26**  
26 #23 Contacts  
.022 (0.56) Max. Dia. Tail

Series 801: **10-26**  
Series 800, 802, 803,804: **10-26**  
Series 805: **12-26**

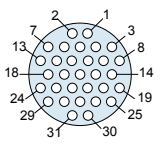
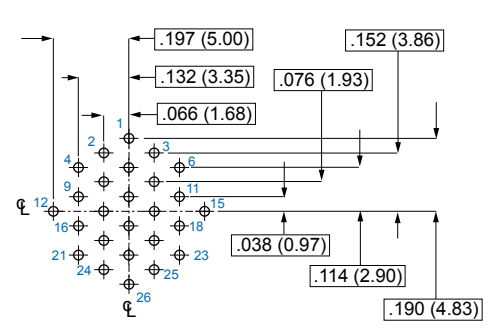
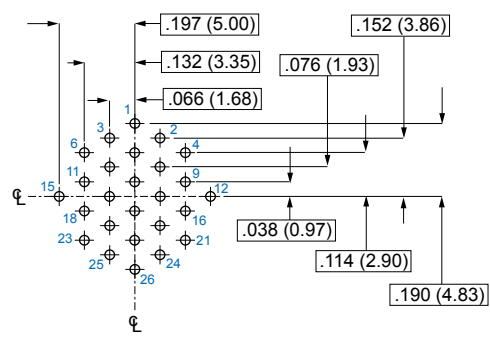

**Insert Arrangement**  
**11-31, 13-31**  
26 #23 Contacts  
.022 (0.56) Max. Dia. Tail

Series 801, 804: **11-31**  
Series 805: **13-31**

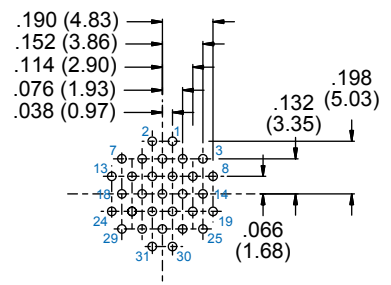
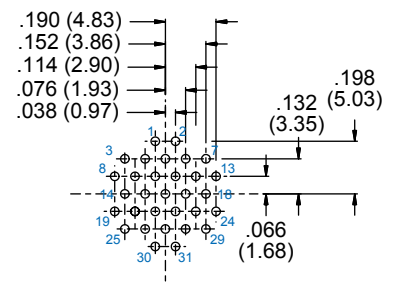

Dimensions in Inches (millimeters) are subject to change without notice.

Series 80 Mighty Mouse Technical Reference  
 Straight PCB Footprints  
 Component Mounting Side of PCB



Insert Arrangement | Pin Connector | Socket Connector

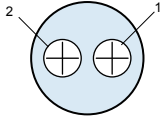

**Insert Arrangement**  
**12-2, 13-2, 15-2**  
 2 #12 Contacts  
 .096 (2.44) Max Dia. Tail

Series 801: **13-2**  
 Series 800, 802, 803,804: **12-2**  
 Series 805: **15-2**

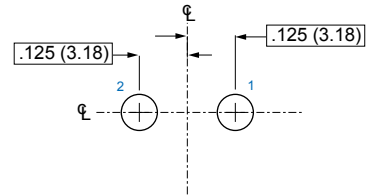
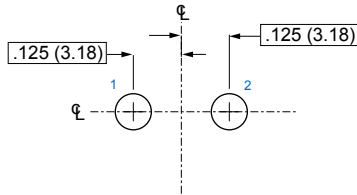

C

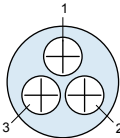

**Insert Arrangement**  
**12-3, 13-3, 15-3**  
 3 #12 Contacts  
 .096 (2.44) Max Dia. Tail

Series 801: **13-3**  
 Series 800, 802, 803,804: **12-3**  
 Series 805: **15-3**

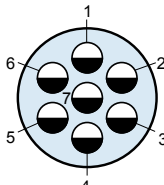
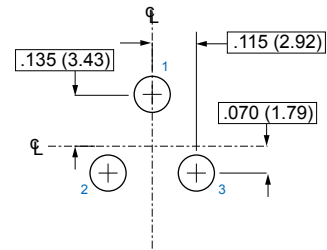
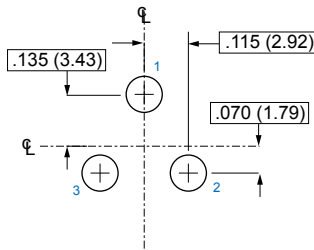

**Insert Arrangement**  
**12-7, 13-7, 15-7**  
 7 #16 Contacts  
 .064 (1.63) Max. Dia. Tail

Series 801: **13-7**  
 Series 800, 802, 803,804: **12-7**  
 Series 805: **15-7**

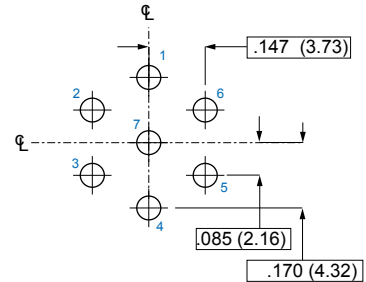
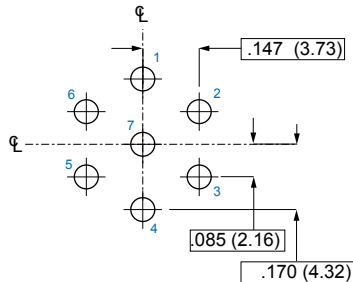

Dimensions in Inches (millimeters) are subject to change without notice.



Series 80 Mighty Mouse Technical Reference  
Straight PCB Footprints  
Component Mounting Side of PCB

Insert Arrangement

Pin Connector

C

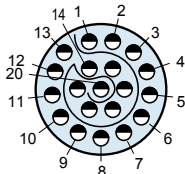

**Insert Arrangement**  
12-220, 13-220, 15-220  
20 #20HD Contacts  
.028 (0.71) Max. Dia. Tail

Series 801: 13-220  
Series 800, 802, 803,804: 12-220  
Series 805: 15-220

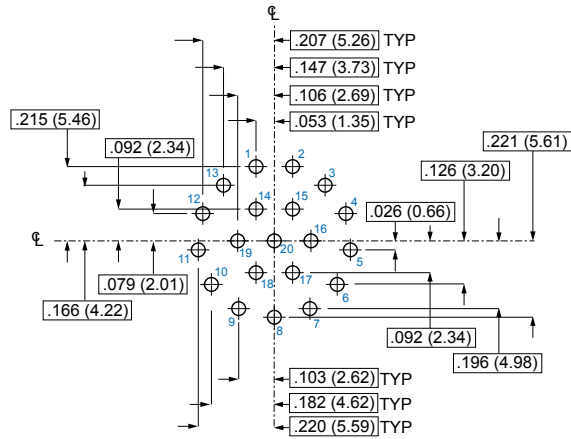

Socket Connector

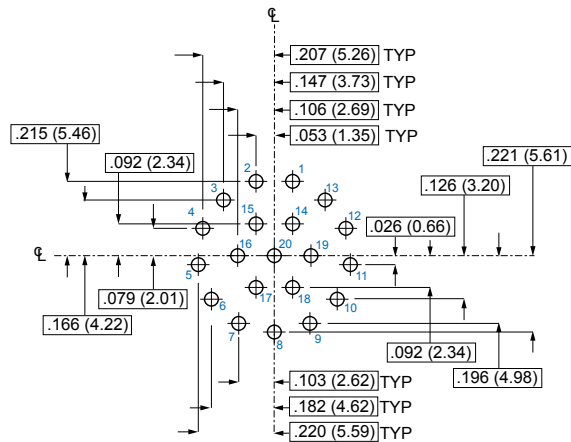

Dimensions in Inches (millimeters) are subject to change without notice.

Series 80 Mighty Mouse Technical Reference  
 Straight PCB Footprints  
 Component Mounting Side of PCB



Insert Arrangement

Pin Connector

Socket Connector

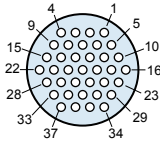

**Insert Arrangement**  
**12-37, 13-37, 15-37**  
 37 #23 Contacts  
 .022 (0.56) Max. Dia. Tail

Series 801: **13-37**  
 Series 800, 802, 803,804: **12-37**  
 Series 805: **15-37**

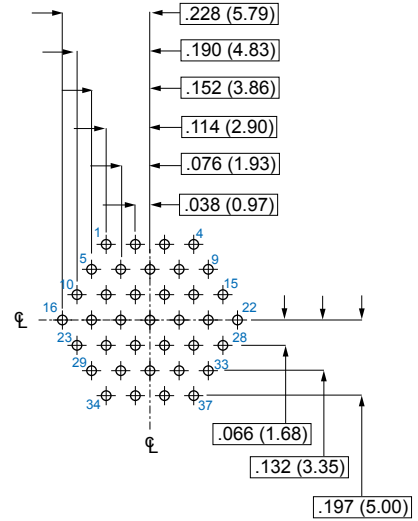
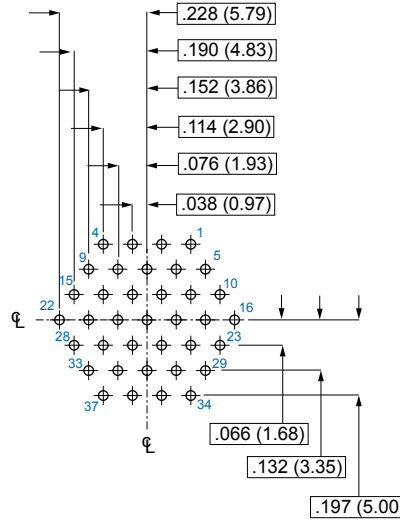

Dimensions in Inches (millimeters) are subject to change without notice.



Series 80 Mighty Mouse Technical Reference  
Straight PCB Footprints  
Component Mounting Side of PCB

Insert Arrangement

Pin Connector

Socket Connector

C

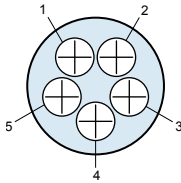

**Insert Arrangement**  
**14-5, 16-5, 18-5**  
5 #12 Contacts  
.096 (2.44) Max Dia. Tail

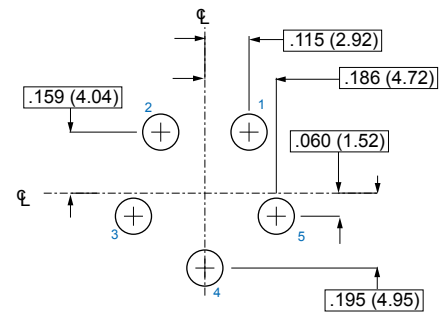
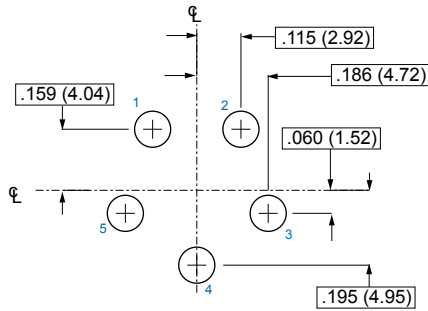

Series 801: **16-5**  
Series 802, 803, 804: **14-5**  
Series 805: **18-5**

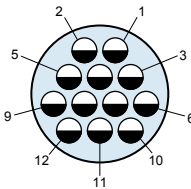

**Insert Arrangement**  
**14-12, 16-12, 18-12**  
12 #16 Contacts  
.064 (1.63) Max Dia. Tail

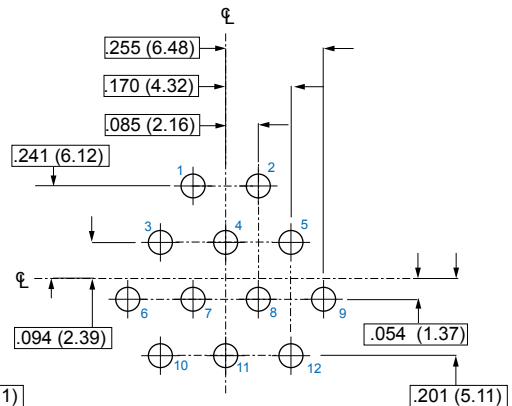
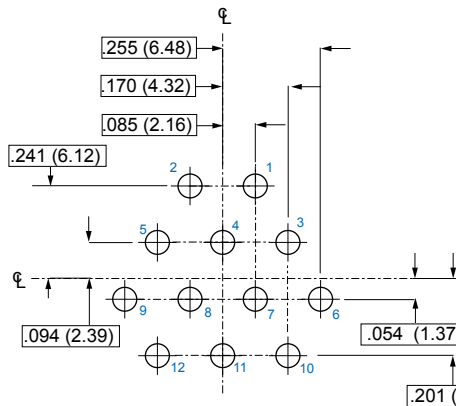

Series 801: **16-12**  
Series 802, 803, 804: **14-12**  
Series 805: **18-12**

Dimensions in Inches (millimeters) are subject to change without notice.

Series 80 Mighty Mouse Technical Reference  
 Straight PCB Footprints  
 Component Mounting Side of PCB



Series 80  
 Mighty Mouse

C

Insert Arrangement

Pin Connector

Socket Connector

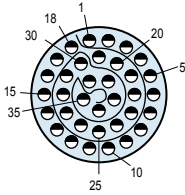

**Insert Arrangement**  
**14-235, 16-235, 18-235**  
 35 #20HD Contacts  
 .028 (0.71) Max. Dia. Tail

Series 801: **16-235**  
 Series 802, 803, 804: **14-235**  
 Series 805: **18-235**

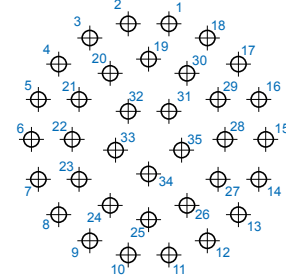
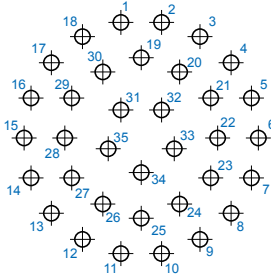

Pin No.	X		Y		Pin No.	X		Y		Pin No.	X		Y	
	In.	mm.	In.	mm.		In.	mm.	In.	mm.		In.	mm.	In.	mm.
1	-.053	-1.35	.301	7.65	13	-.234	-5.94	-.196	-4.98	25	.000	0.00	-.209	-5.31
2	.053	1.35	.301	7.65	14	-.287	-7.29	-.104	-2.64	26	-.100	-2.54	-.172	-4.37
3	.153	3.89	.264	6.71	15	-.305	-7.75	.000	0.00	27	-.181	-4.60	-.104	-2.64
4	.234	5.94	.196	4.98	16	-.287	7.29	.104	2.64	28	-.199	-5.05	.000	0.00
5	.287	7.29	.104	2.64	17	-.234	-5.94	.196	4.98	29	-.181	-4.60	.104	2.64
6	.305	7.75	.000	0.00	18	-.153	-3.89	.264	6.71	30	-.100	-2.54	.172	4.37
7	.287	7.29	-.104	-2.64	19	.000	0.00	.209	5.31	31	-.053	-1.35	.073	1.85
8	.234	5.94	-.196	-4.98	20	.100	2.54	.172	4.37	32	.053	1.35	.073	1.85
9	.153	3.89	-.264	-6.71	21	.181	4.60	.104	2.64	33	.086	2.18	-.028	-0.71
10	.053	1.35	-.301	-7.65	22	.199	5.05	.000	0.00	34	.000	0.00	-.090	-2.29
11	-.053	-1.35	-.301	-7.65	23	.181	4.60	-.104	-2.64	35	-.086	-2.18	-.028	-0.71
12	-.153	-3.89	-.264	-6.71	24	.100	2.54	-.172	-4.37					

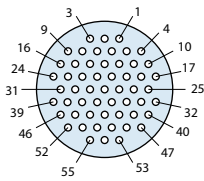

**Insert Arrangement**  
**14-55, 16-55, 18-55**  
 55 #23 Contacts  
 .022 (0.56) Max. Dia. Tail

Series 801: **16-55**  
 Series 802, 803, 804: **14-55**  
 Series 805: **18-55**

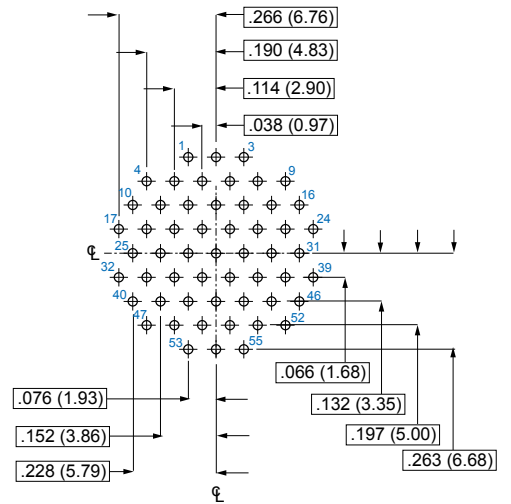
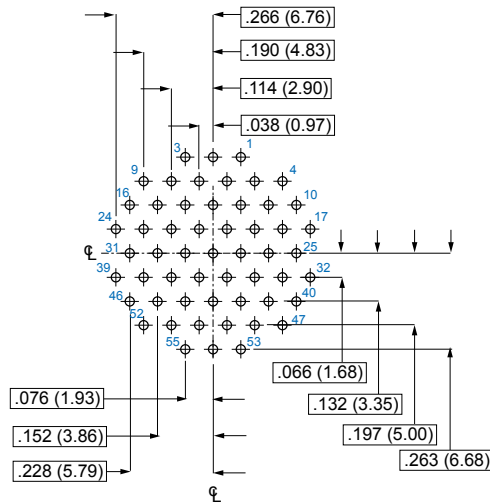

Dimensions in Inches (millimeters) are subject to change without notice.





Series 80 Mighty Mouse Technical Reference  
Straight PCB Footprints  
Component Mounting Side of PCB

Insert Arrangement	Pin Connector	Socket Connector
--------------------	---------------	------------------

C

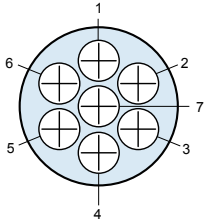

**Insert Arrangement**  
**15-7, 17-7, 19-7**  
7 #12 Contacts  
.096 (2.44) Max Dia. Tail

- Series 801: 17-7
- Series 802: 15-7
- Series 805: 19-7

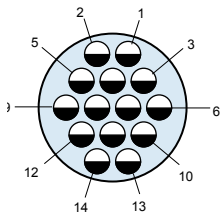
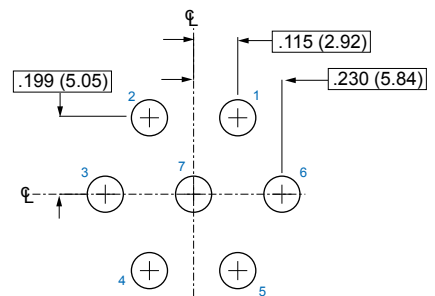
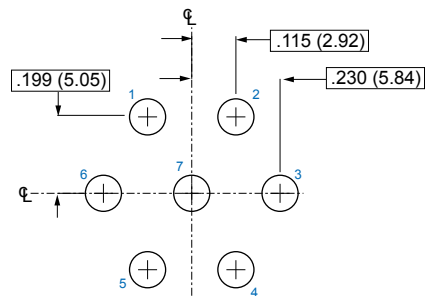

**Insert Arrangement**  
**15-14, 17-14, 19-14**  
14 #16 Contacts  
.064 (1.63) Max Dia. Tail

- Series 801: 17-14
- Series 802: 15-14
- Series 805: 19-14

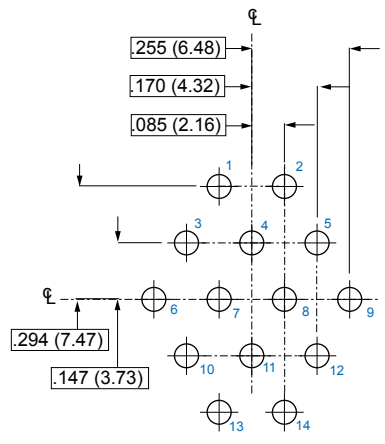
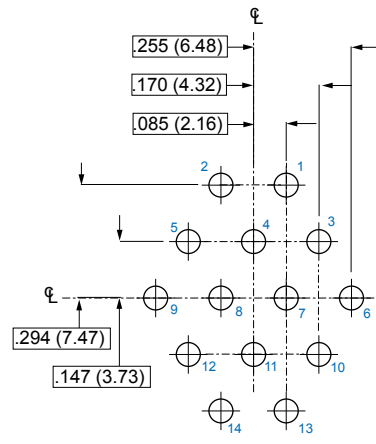

Dimensions in Inches (millimeters) are subject to change without notice.

Series 80 Mighty Mouse Technical Reference  
 Straight PCB Footprints  
 Component Mounting Side of PCB



Insert Arrangement

Pin Connector

Socket Connector

C

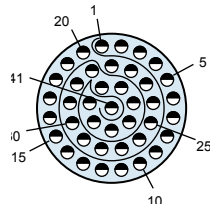

**Insert Arrangement**  
**15-241, 17-241, 18-241**  
 41 #20HD Contacts  
 .028 (0.71) Max. Dia. Tail

Series 801: **17-241**  
 Series 802: **15-241**  
 Series 805: **19-241**

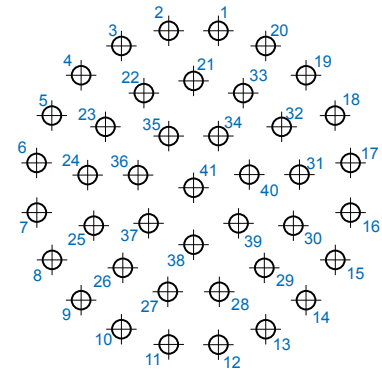
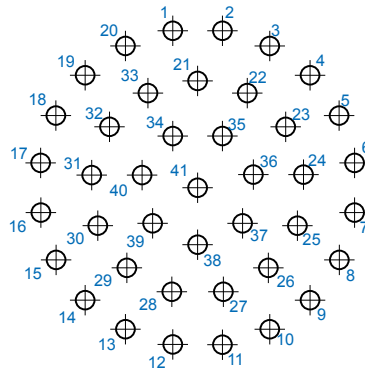

Pin No.	X		Y		Pin No.	X		Y		Pin No.	X		Y	
	In.	mm.	In.	mm.		In.	mm.	In.	mm.		In.	mm.	In.	mm.
1	-.053	-1.35	.335	8.51	15	-.302	-7.67	-.154	-3.91	29	-.151	-3.84	-.171	-4.34
2	.053	1.35	.335	8.51	16	-.335	-8.51	-.053	-1.35	30	-.213	-5.41	-.081	-2.06
3	.154	3.91	.302	7.67	17	-.335	-8.51	.053	1.35	31	-.226	-5.74	.028	0.71
4	.240	6.10	.240	6.10	18	-.302	-7.67	.154	3.91	32	-.188	-4.78	.130	3.30
5	.302	7.67	.154	3.91	19	-.240	-6.10	.240	6.10	33	-.106	-2.69	.202	5.13
6	.335	8.51	-.053	-1.35	20	-.154	-3.91	.302	7.67	34	-.053	-1.35	.110	2.79
7	.335	8.51	-.053	-1.35	21	.000	0.00	.228	5.79	35	.053	1.35	.110	2.79
8	.302	7.67	-.154	-3.91	22	.106	2.69	.202	5.13	36	.119	3.02	.027	0.69
9	.240	6.10	-.240	-6.10	23	.188	4.78	.130	3.30	37	.096	2.44	-.076	-1.93
10	.154	3.91	-.302	-7.67	24	.226	5.74	.028	0.71	38	.000	0.00	-.122	-3.10
11	.053	1.35	-.335	-8.51	25	.213	5.41	-.081	-2.06	39	-.096	-2.44	-.076	-1.93
12	-.053	-1.35	-.335	-8.51	26	.151	3.84	-.171	-4.34	40	-.119	-3.02	.027	0.69
13	-.154	-3.91	-.302	-7.67	27	.055	1.40	-.222	-5.64	41	.000	0.00	.000	0.00
14	-.240	-6.10	-.240	-6.10	28	-.055	-1.40	-.222	-5.64					

Dimensions in Inches (millimeters) are subject to change without notice.



Series 80 Mighty Mouse Technical Reference  
Straight PCB Footprints  
Component Mounting Side of PCB

Insert Arrangement

Pin Connector

C

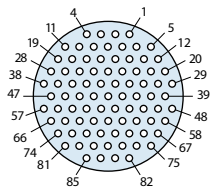

**Insert Arrangement**  
**15-85, 17-85, 19-85**  
85 #23 Contacts  
.022 (0.56) Max. Dia. Tail

Series 801: **17-85**  
Series 802: **15-85**  
Series 805: **19-85**

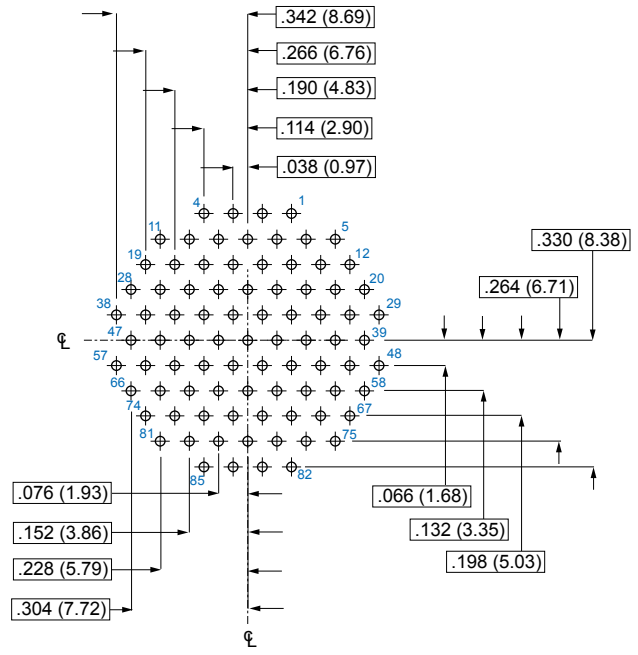

Socket Connector

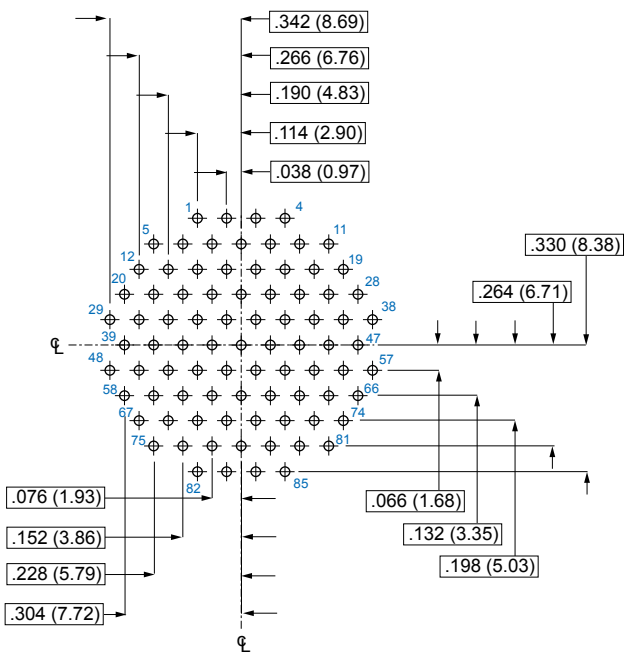

Dimensions in Inches (millimeters) are subject to change without notice.

Series 80 Mighty Mouse Technical Reference  
 Straight PCB Footprints  
 Component Mounting Side of PCB



Insert Arrangement

Pin Connector

Socket Connector

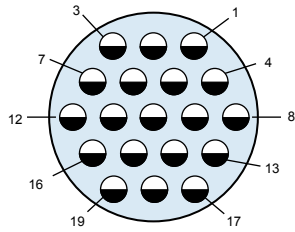

**Insert Arrangement**  
**19-19, 19-19, 21-19**  
 19 #16 Contacts  
 .064 (1.63) Max Dia. Tail

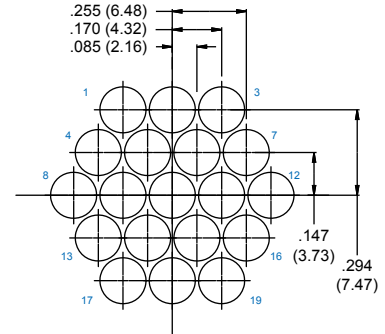
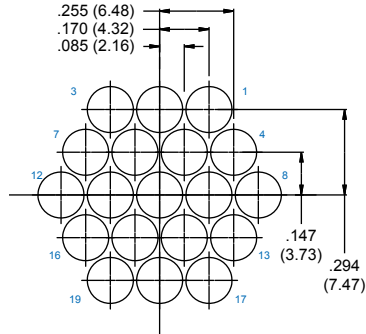

Series 801: **19-19**  
 Series 805: **21-19**

Dimensions in Inches (millimeters) are subject to change without notice.



# Series 80 Mighty Mouse Technical Reference

## Straight PCB Footprints

### Component Mounting Side of PCB

#### Insert Arrangement

#### Pin Connector

C

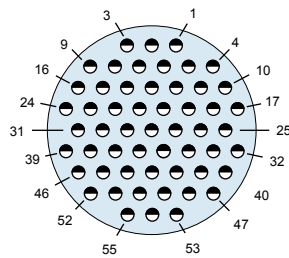

#### Insert Arrangement 19-255 21-255

55 #20HD Contacts  
.028 (0.71) Max. Dia. Tail

Series 801: 19-255  
Series 802: 19-255  
Series 805: 21-255

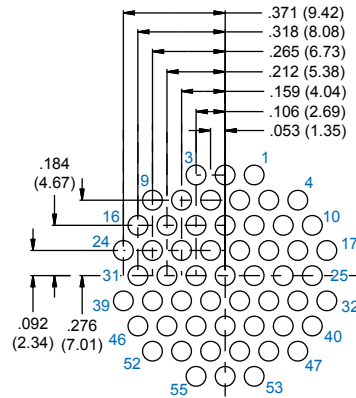

#### Socket Connector

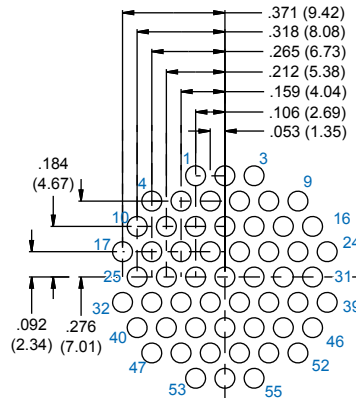

Dimensions in Inches (millimeters) are subject to change without notice.

Series 80 Mighty Mouse Technical Reference  
 Straight PCB Footprints  
 Component Mounting Side of PCB



Insert Arrangement

Pin Connector

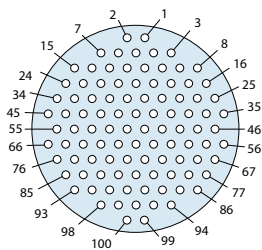

**Insert Arrangement**  
**19-100 21-100**  
 100 #23 Contacts  
 .022 (.559) Max Dia

Series 801: **19-100**  
 Series 802: **19-100**  
 Series 805: **21-100**

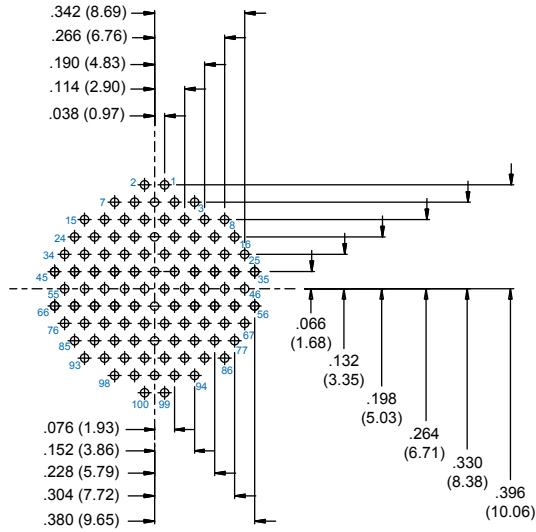

Socket Connector

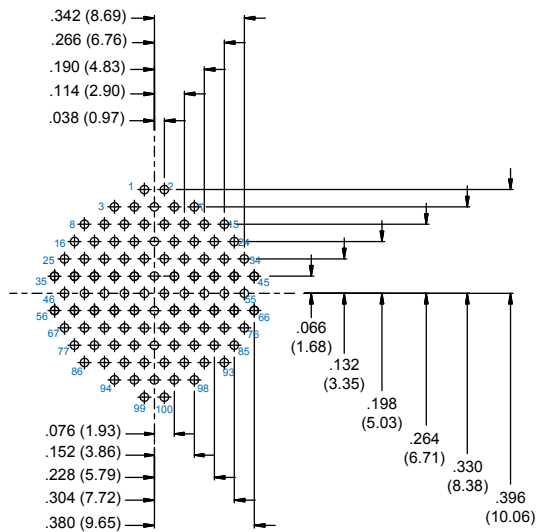

Dimensions in Inches (millimeters) are subject to change without notice.



Series 80 Mighty Mouse Technical Reference  
Straight PCB Footprints  
Component Mounting Side of PCB

Insert Arrangement

Pin Connector

C

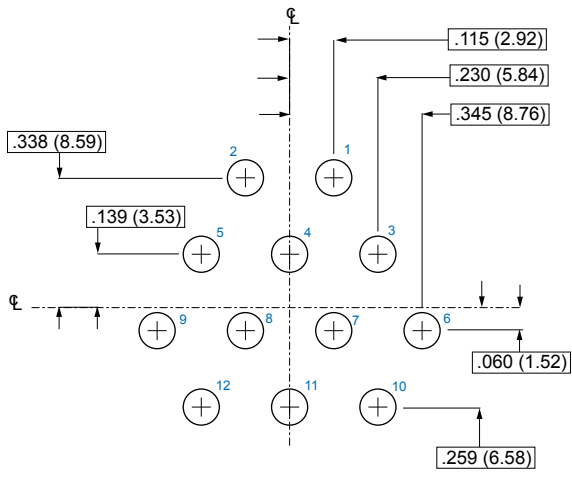
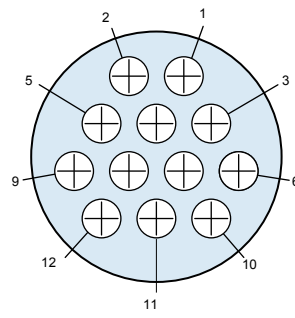

Socket Connector

**Insert Arrangement**  
**21-12, 23-12**  
12 #12 Contacts  
.096 (2.44) Max Dia

Series 801: **21-12**  
Series 802 : **21-12**  
Series 805: **23-12**

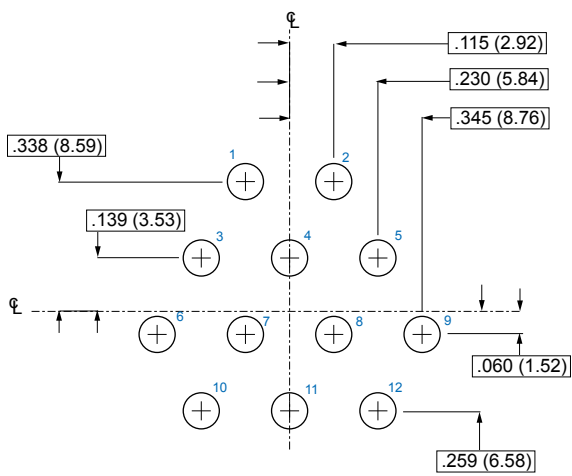

Dimensions in Inches (millimeters) are subject to change without notice.



Series 80 Mighty Mouse Technical Reference  
 Straight PCB Footprints  
 Component Mounting Side of PCB



Insert Arrangement

Pin Connector

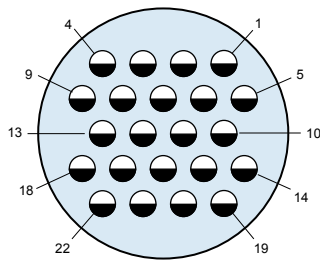

**Insert Arrangement**  
**21-22, 23-22**  
 22 #16 Contacts  
 .064 (1.63 Max. Dia. Tail)

Series 801: **21-22**  
 Series 800,802, 803, 804: **21-22**  
 Series 805: **23-22**

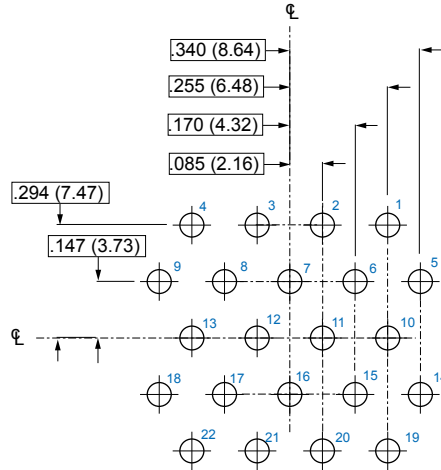

Socket Connector

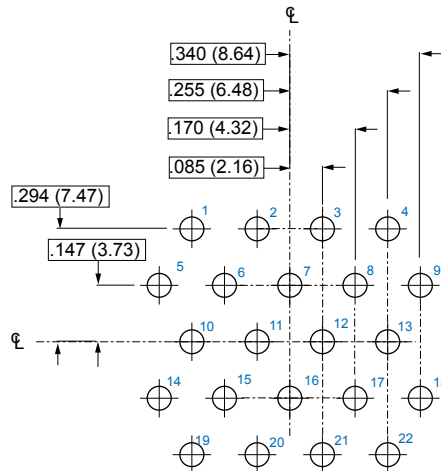

Dimensions in Inches (millimeters) are subject to change without notice.



Series 80 Mighty Mouse Technical Reference  
Straight PCB Footprints  
Component Mounting Side of PCB

Insert Arrangement

Pin Connector

C

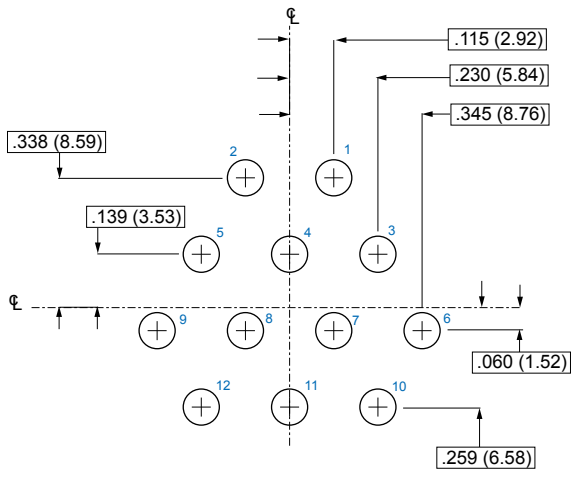
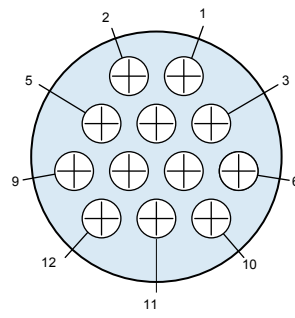

Socket Connector

**Insert Arrangement**  
**21-12, 23-12**  
12 #12 Contacts  
.096 (2.44) Max Dia

Series 801: **21-12**  
Series 802 : **21-12**  
Series 805: **23-12**

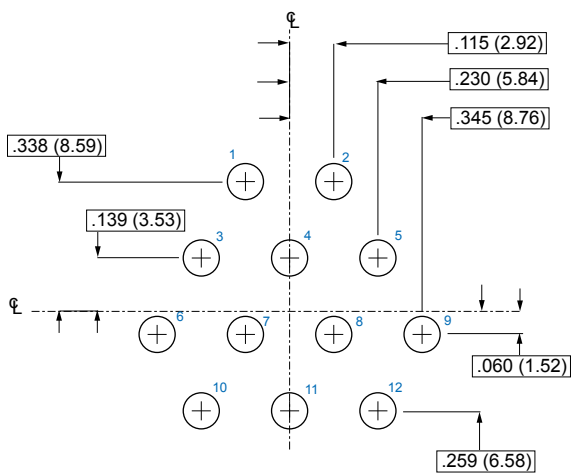

Dimensions in Inches (millimeters) are subject to change without notice.

Series 80 Mighty Mouse Technical Reference  
 Straight PCB Footprints  
 Component Mounting Side of PCB



Insert Arrangement

Pin Connector

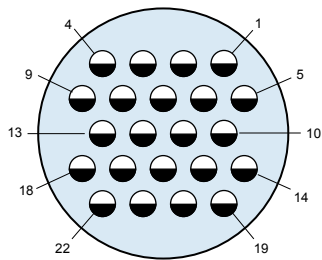

**Insert Arrangement**  
**21-22, 23-22**  
 22 #16 Contacts  
 .064 (1.63 Max. Dia. Tail)

Series 801: **21-22**  
 Series 800,802, 803, 804: **21-22**  
 Series 805: **23-22**

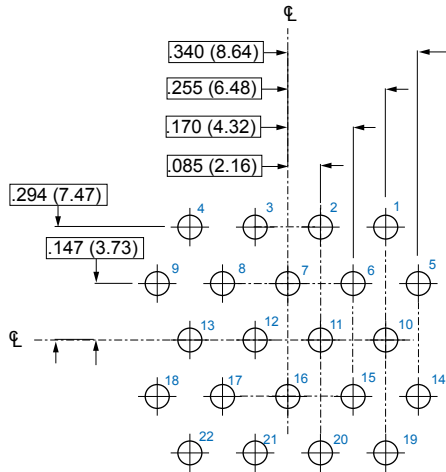

Socket Connector

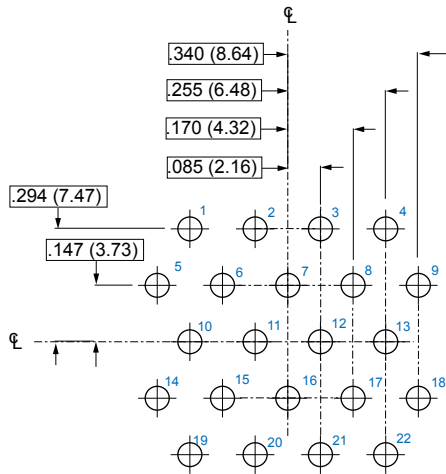

Dimensions in Inches (millimeters) are subject to change without notice.



Series 80 Mighty Mouse Technical Reference  
Straight PCB Footprints  
Component Mounting Side of PCB

Insert Arrangement

Pin Connector

Socket Connector

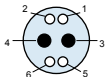

Insert Arrangement

8-200, 10-200

- 2 #20 Contacts
- .028 (0.71) Max. Dia. Tail
- 4 #23 Contacts
- .022 (0.56) Max. Dia. Tail

Series 801: 8-200  
Series 800, 802, 803,804: 8-200  
Series 805: 10-200

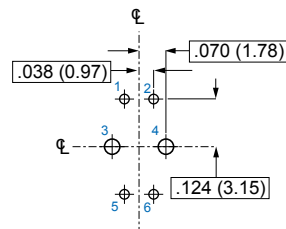
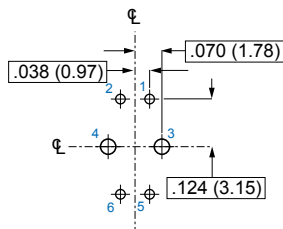

C

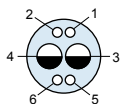

Insert Arrangement

9-200, 11-200

- 4 #23 Contacts
- .022 (0.56) Max. Dia. Tail
- 2 #16 Contacts
- .064 (1.63) Max. Dia. Tail

Series 801: 9-200  
Series 800, 802, 803,804: 9-200  
Series 805: 11-200

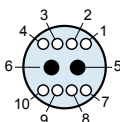
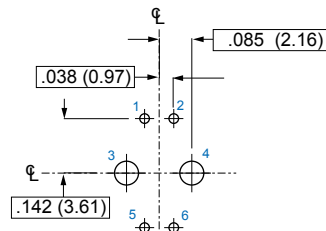
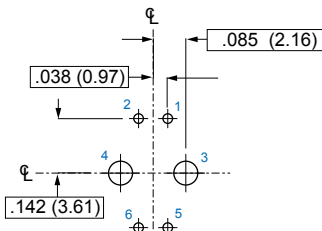

Insert Arrangement

9-201, 11-201

- 2 #20 Contacts
- .028 (0.71) Max Dia Tail
- 8 #23 Contacts
- .022 (0.56) Max Dia Tail

Series 801: 9-201  
Series 800, 802, 803,804: 9-201  
Series 805: 11-201

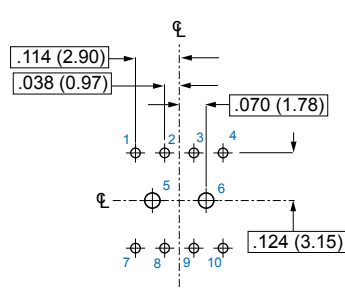
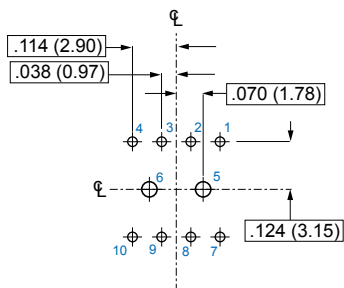

Dimensions in Inches (millimeters) are subject to change without notice.

Series 80 Mighty Mouse Technical Reference  
 Straight PCB Footprints  
 Component Mounting Side of PCB



Series 80  
 Mighty Mouse

Insert Arrangement | Pin Connector | Socket Connector

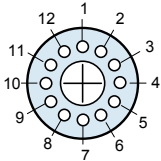

**Insert Arrangement**  
**10-200, 12-200**  
 1 #12 Contact  
 .096 (2.44) Max Dia Tail  
 12 #23 Contacts  
 .022 (0.56) Max. Dia. Tail

Series 801: **10-200**  
 Series 800, 802, 803,804: **10-200**  
 Series 805: **12-200**

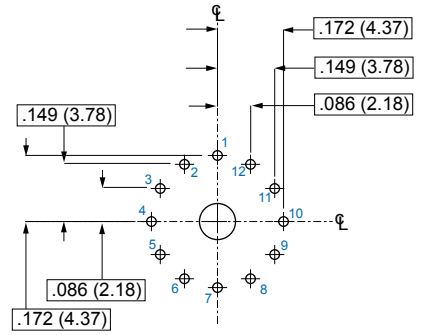
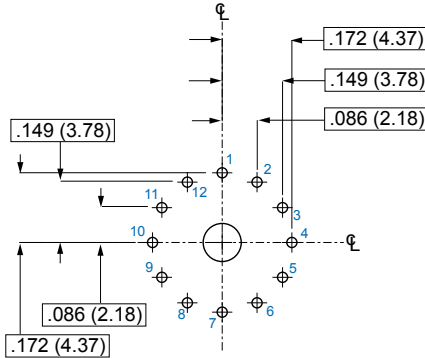

C

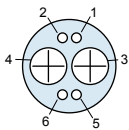

**Insert Arrangement**  
**10-201, 12-201**  
 2 #12 Contacts  
 .096 (2.44) Max. Dia. Tail  
 4 #23 Contacts  
 .022 (0.56) Max. Dia. Tail

Series 801: **10-201**  
 Series 800, 802, 803,804: **10-201**  
 Series 805: **12-201**

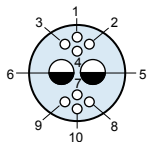
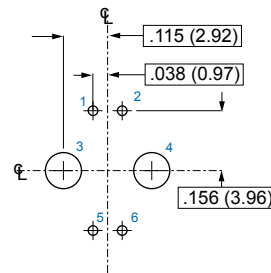
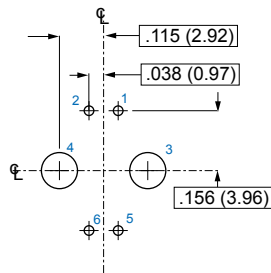

**Insert Arrangement**  
**10-202, 12-202**  
 2 #16 Contacts  
 .064 (1.63) Max. Dia. Tail  
 8 #23 Contacts  
 .022 (0.5 Max. Dia. Tail)

Series 801: **10-203**  
 Series 800, 802, 803,804: **10-202**  
 Series 805: **12-202**

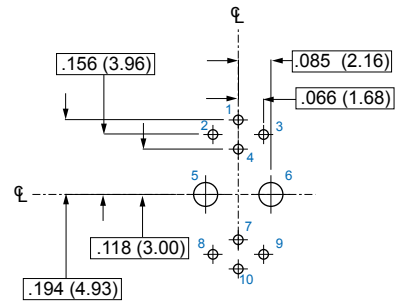
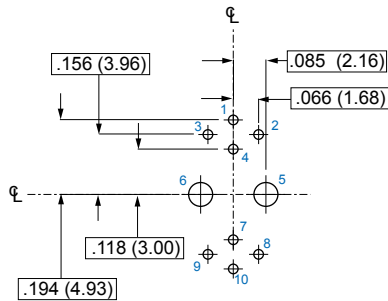

Dimensions in Inches (millimeters) are subject to change without notice.



Series 80 Mighty Mouse Technical Reference  
Straight PCB Footprints  
Component Mounting Side of PCB

Insert Arrangement

Pin Connector

Socket Connector

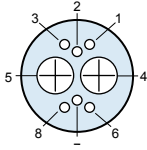

**Insert Arrangement**  
**12-200, 13-200, 15-200**  
2 #12 Contacts  
.096 (2.44) Max. Dia. Tail  
6 #23 Contacts  
.022 (0.56) Max. Dia. Tail

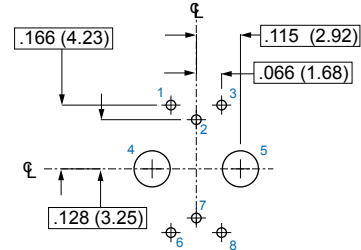
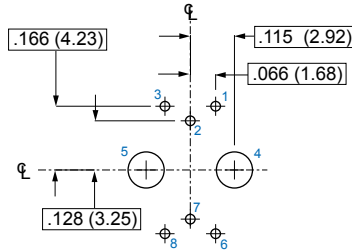

Series 801: **13-200**  
Series 800, 802, 803,804: **12-200**  
Series 805: **15-200**

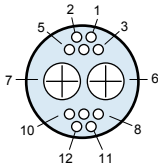

**Insert Arrangement**  
**12-201, 13-201, 15-201**  
2 #12 Contacts  
.096 (2.44) Max. Dia. Tail  
10 #23 Contacts  
.022 (0.56) Max. Dia. Tail

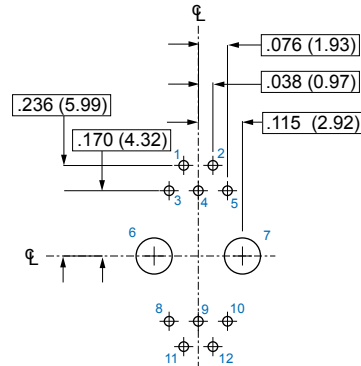
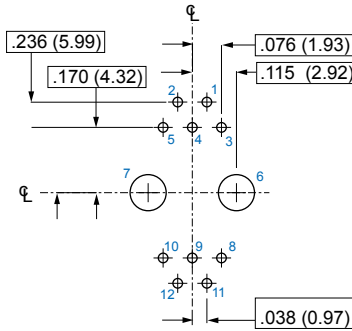

Series 801: **13-201**  
Series 800, 802, 803,804: **12-201**  
Series 805: **15-201**

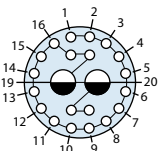

**Insert Arrangement**  
**12-202, 13-202, 15-202**  
2 #16 Contacts  
.064 (1.63) Max. Dia. Tail  
20 #23 Contacts  
.028 (0.71) Max. Dia. Tail

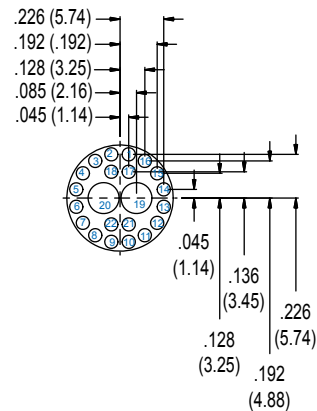
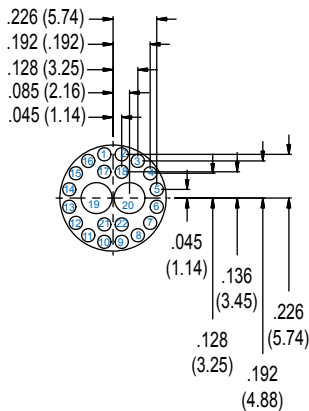

Series 801: **13-202**  
Series 800, 802, 803,804: **12-202**  
Series 805: **15-202**

Dimensions in Inches (millimeters) are subject to change without notice.

Series 80 Mighty Mouse Technical Reference  
 Straight PCB Footprints  
 Component Mounting Side of PCB



Insert Arrangement | Pin Connector | Socket Connector

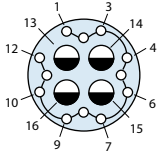

**Insert Arrangement**  
**12-203, 13-203, 15-203**  
 4 #16 Contacts  
 .064 (1.63) Max. Dia. Tail  
 12 #23 Contacts  
 .022 (0.71) Max. Dia. Tail

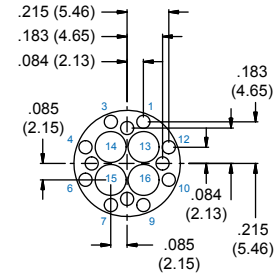
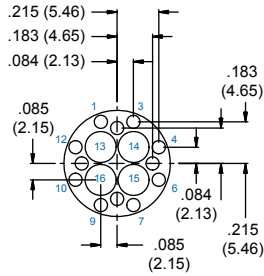

C

Series 801: **13-203**  
 Series 800, 802, 803,804: **12-203**  
 Series 805: **15-203**

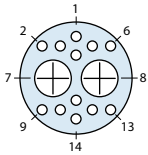

**Insert Arrangement**  
**12-204, 13-204, 15-204**  
 2 #12 Contacts  
 .096 (2.44) Max. Dia. Tail  
 12 #23 Contacts  
 .022 (0.71) Max. Dia. Tail

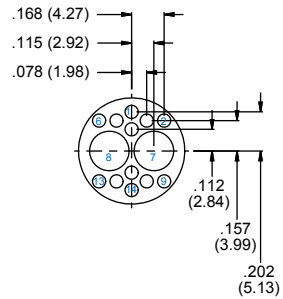
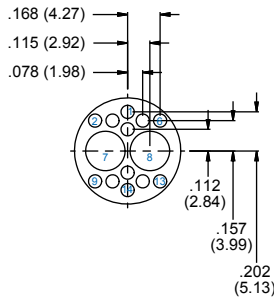

Series 801: **13-204**  
 Series 800, 802, 803,804: **12-204**  
 Series 805: **15-204**

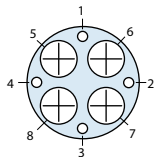

**Insert Arrangement**  
**12-205, 13-205, 15-205**  
 4 #12 Contacts  
 .096 (2.44) Max. Dia. Tail  
 4 #23 Contacts  
 .022 (0.71) Max. Dia. Tail

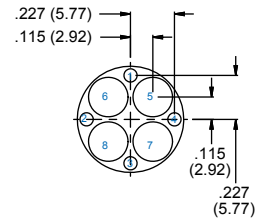
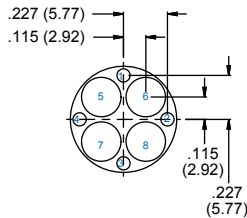

Series 801: **13-205**  
 Series 800, 802, 803,804: **12-205**  
 Series 805: **15-205**

Dimensions in Inches (millimeters) are subject to change without notice.





# Series 80 Mighty Mouse Technical Reference

## Combo Arrangements

### Straight PCB Footprints

### Component Mounting Side of PCB

#### Insert Arrangement

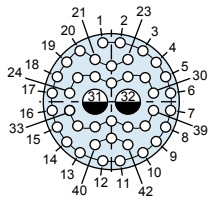

**Insert Arrangement**  
**14-204, 16-204, 18-204**  
 2 #16 Contacts  
 .064 (1.63) Max. Dia. Tail  
 40 #23 Contacts  
 .022 (0.71) Max. Dia. Tail

Series 801: **16-204**  
 Series 802, 803,804: **14-204**  
 Series 805: **18-204**

#### Pin Connector

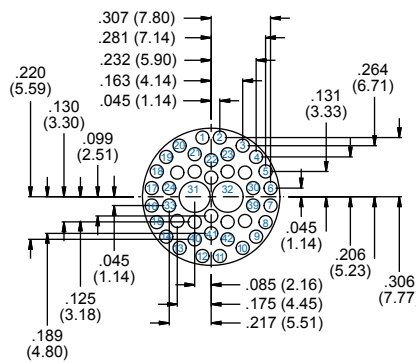

#### Socket Connector

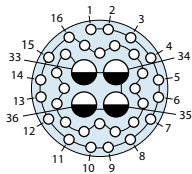
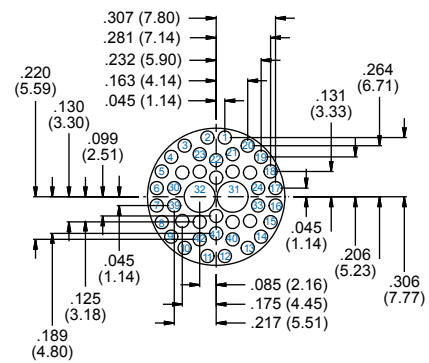

**Insert Arrangement**  
**14-205, 16-205, 18-205**  
 4 #16 Contacts  
 .064 (1.63) Max. Dia. Tail  
 32 #23 Contacts  
 .022 (0.71) Max. Dia. Tail

Series 801: **16-205**  
 Series 802, 803,804: **14-205**  
 Series 805: **18-205**

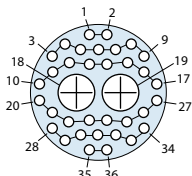
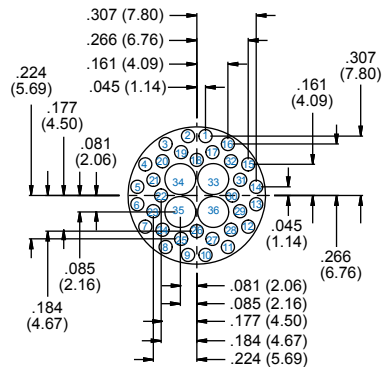
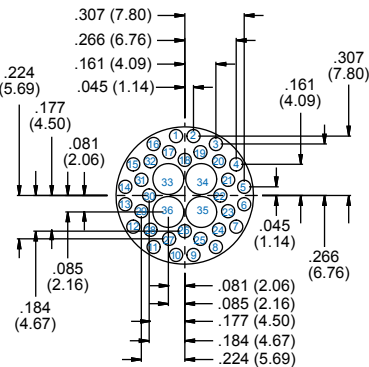

**Insert Arrangement**  
**14-206, 16-206, 18-206**  
 2 #12 Contacts  
 .096 (2.44) Max. Dia. Tail  
 34 #23 Contacts  
 .022 (0.71) Max. Dia. Tail

Series 801: **16-206**  
 Series 802, 803,804: **14-206**  
 Series 805: **18-206**

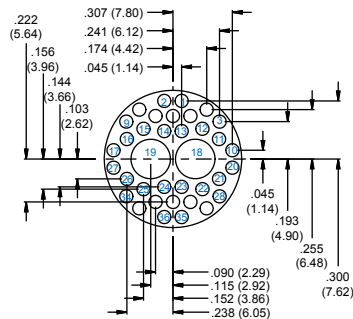
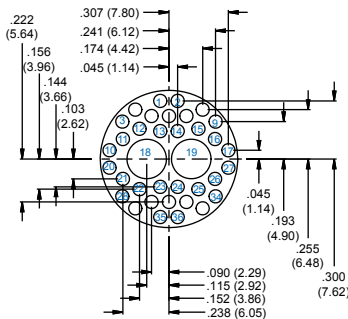

Dimensions in Inches (millimeters) are subject to change without notice.

Series 80 Mighty Mouse Technical Reference  
 Combo Arrangements  
 Straight PCB Footprints  
 Component Mounting Side of PCB



Insert Arrangement

Pin Connector

Socket Connector

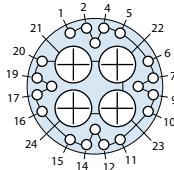

**Insert Arrangement**  
**14-207, 16-207, 18-207**  
 4 #12 Contacts  
 .096 (2.44) Max. Dia. Tail  
 20 #23 Contacts  
 .022 (0.71) Max. Dia. Tail

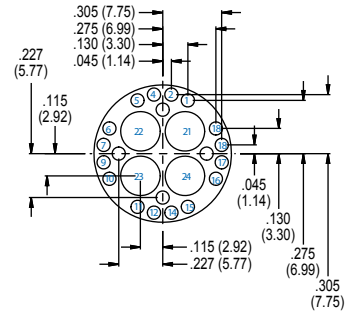
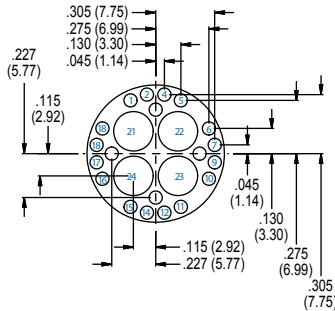

Series 801: **16-207**  
 Series 802, 803, 804: **14-207**  
 Series 805: **18-207**

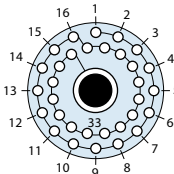

**Insert Arrangement**  
**16-208, 18-208**  
 1 #8 Contacts  
 .182 (4.62) Max. Dia. Tail  
 32 #23 Contacts  
 .022 (0.71) Max. Dia. Tail

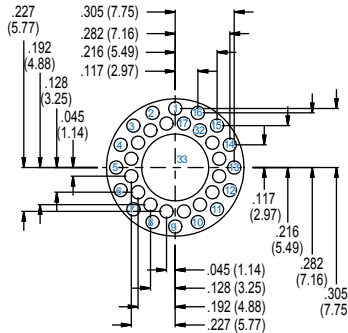
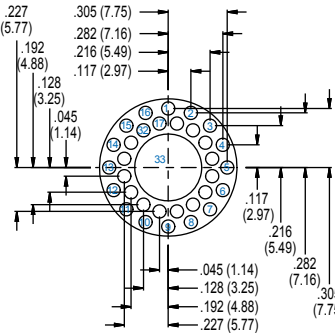

Series 801: **16-208**  
 Series 805: **18-208**

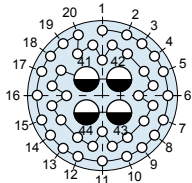

**Insert Arrangement**  
**15-203, 17-203, 19-203**  
 4 #16 Contacts  
 .064 (1.63) Max. Dia. Tail  
 40 #23 Contacts  
 .022 (0.71) Max. Dia. Tail

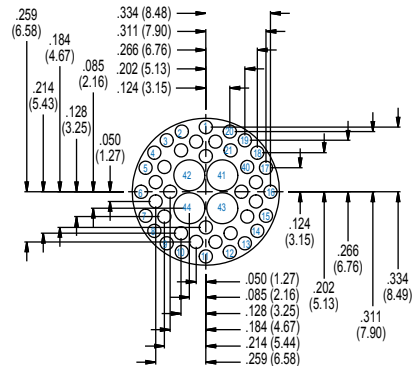
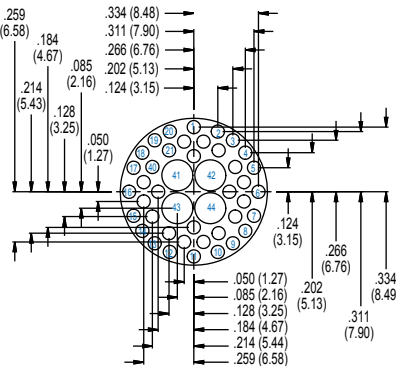

Series 801: **17-203**  
 Series 802: **15-203**  
 Series 805: **19-203**

Dimensions in Inches (millimeters) are subject to change without notice.



# Series 80 Mighty Mouse Technical Reference

## Combo Arrangements

### Straight PCB Footprints

#### Component Mounting Side of PCB

### Insert Arrangement

### Pin Connector

### Socket Connector

C

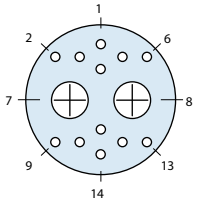

**Insert Arrangement**  
**15-204, 17-204, 19-204**  
 4 #12 Contacts  
 .096 (2.44) Max. Dia. Tail  
 28 #23 Contacts  
 .022 (0.71) Max. Dia. Tail

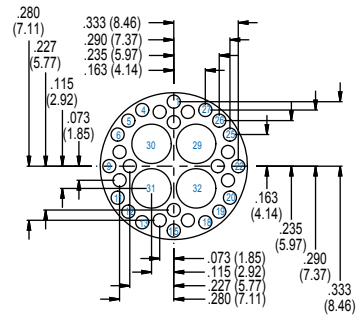
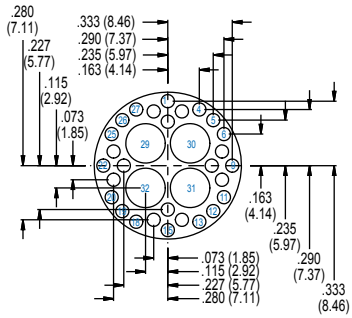

Series 801: **17-204**  
 Series 802: **15-204**  
 Series 805: **19-204**

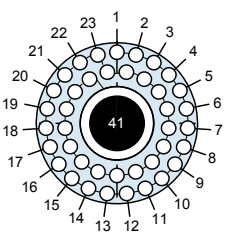

**Insert Arrangement**  
**17-205, 19-205**  
 1 #8 Contacts  
 .182 (4.62) Max. Dia. Tail  
 40 #23 Contacts  
 .022 (0.71) Max. Dia. Tail

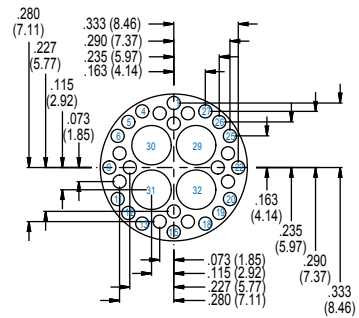
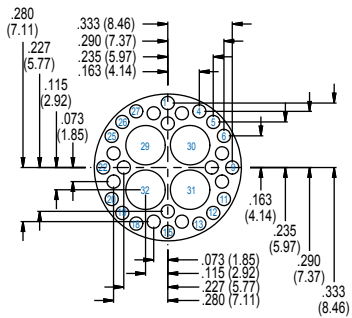

Series 801: **17-205**  
 Series 805: **19-205**

Dimensions in Inches (millimeters) are subject to change without notice.

Series 80 Mighty Mouse Technical Reference  
 Combo Arrangements  
 Straight PCB Footprints  
 Component Mounting Side of PCB



Insert Arrangement | Pin Connector | Socket Connector

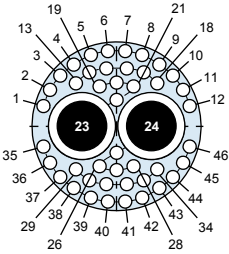

**Insert Arrangement**  
**19-201, 21-201**  
 2 #8 Contacts  
 .182 (4.62) Max. Dia. Tail  
 44 #23 Contacts  
 .022 (0.71) Max. Dia. Tail

Series 801: **19-201**  
 Series 805: **21-201**

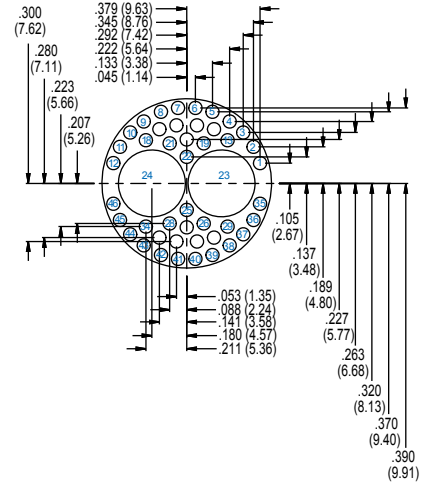
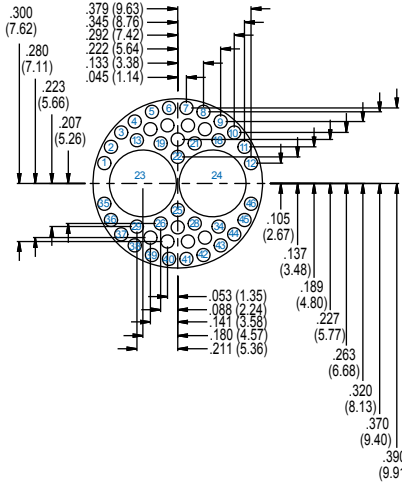

C

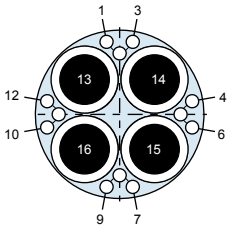

**Insert Arrangement**  
**19-202, 21-202**  
 4 #8 Contacts  
 .182 (4.62) Max. Dia. Tail  
 12 #23 Contacts  
 .022 (0.71) Max. Dia. Tail

Series 801: **19-202**  
 Series 805: **21-202**

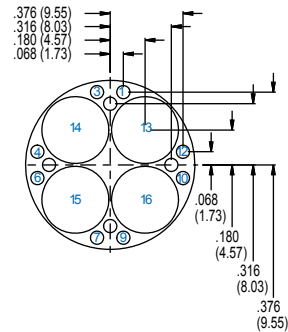
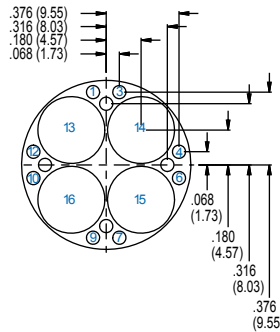

Dimensions in Inches (millimeters) are subject to change without notice.



**Series 80 Mighty Mouse Technical Reference**  
**Combo Arrangements**  
**Straight PCB Footprints**  
**Component Mounting Side of PCB**

**Insert Arrangement**

**Pin Connector**

**Socket Connector**

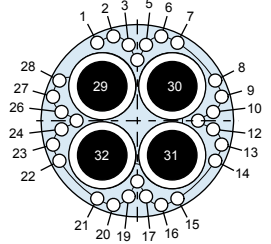

**Insert Arrangement**  
**21-200, 23-200**  
 4 #8 Contacts  
 .182 (4.62) Max. Dia. Tail  
 28 #23 Contacts  
 .022 (0.71) Max. Dia. Tail

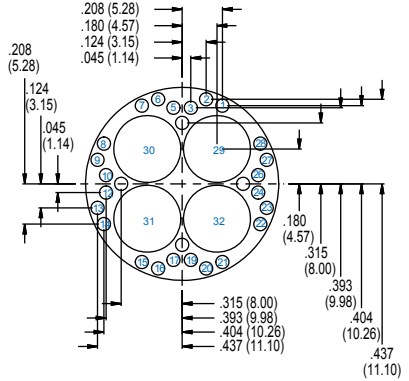
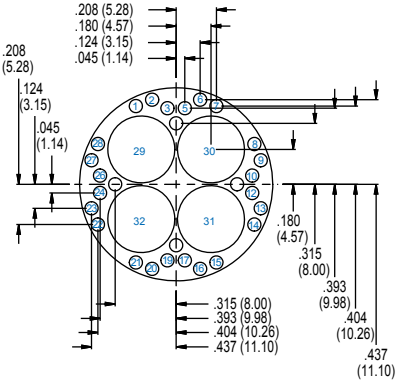

Series 801: **21-200**  
 Series 805: **23-200**

Dimensions in Inches (millimeters) are subject to change without notice.

# Series 80 Mighty Mouse Technical Reference Recommended Torque Values



Series 800 Recommended Torque Values						
Series 800	Coupling Torque		Jam Nut Tightening		Backshell Tightening	
	In-lbs.		In-lbs.		In-lbs.	
	Min.	Max.	Min.	Max.	Min.	Max.
5	16	20	20	25	12	16
6	18	22	20	25	14	18
7	20	24	20	25	16	20
8	20	24	20	25	16	20
9	20	24	25	30	16	20
10	20	24	25	30	16	20
12	20	24	25	30	16	20

Series 801, 802, 803, 804, 805 Recommended Torque Values							
Shell Size Series 801, 802, 803, 804	Shell Size Series 805	Coupling Torque		Jam Nut Tightening		Backshell Tightening	
		In-lbs.		In-lbs.		In-lbs.	
		Min.	Max.	Min.	Max.	Min.	Max.
5	-	16	20	20	25	12	16
6	8	18	22	20	25	14	18
7	9	20	24	20	25	16	20
8	10	22	26	20	25	18	22
9	11	24	28	20	25	20	24
10	12	26	30	25	30	22	26
12, 13	15	32	36	25	30	28	32
14, 16	18	38	42	25	30	28	32
15, 17	19	40	44	25	30	28	32
21	23	48	52	25	30	28	32

Series 804 Recommended Mate/Demate Values	
Shell Size/Insert Arrangement	In-lbs.
5-3	11
6-4	11
6-7	12
7-10	12
8-13	13
9-19	14
10-26	16

Dimensions in Inches (millimeters) are subject to change without notice.



Series 800 Mighty Mouse  
Flange Gaskets 809-108

Flange Gaskets for Series 800 Mighty Mouse Receptacles

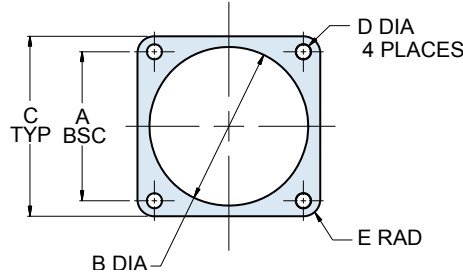
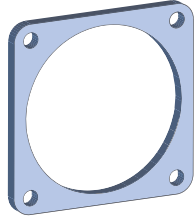

These flange gaskets provide sealing between square flange receptacles and the mounting panel. Choose fluorosilicone, Viton®, or conductive fluorosilicone material (Chomerics 1298 silver-filled). Gaskets are .032" (0.8) thick.

Shell Size	Part Number			Dimensions									
	Fluorosilicone	Viton®	Conductive Fluorosilicone	A Bsc.		B Dia.		C Typ.		D Dia.		E Rad.	
				In.	mm.	In.	mm.	In.	mm.	In.	mm.	In.	mm.
5	809-108F01	809-108V01	809-108X01	.363	9.22	.342	8.69	.527	13.39	.093	2.36	.078	1.98
6	809-108F02	809-108V02	809-108X02	.423	10.74	.405	10.29	.588	14.94	.093	2.36	.078	1.98
7	809-108F03	809-108V03	809-108X03	.483	12.27	.467	11.86	.650	16.51	.125	3.18	.078	1.98
8	809-108F04	809-108V04	809-108X04	.542	13.77	.530	13.46	.709	18.01	.125	3.18	.078	1.98
9	809-108F05	809-108V05	809-108X05	.719	18.26	.593	15.06	.938	23.83	.125	3.18	.105	2.67
10	809-108F06	809-108V06	809-108X06	.719	18.26	.655	16.64	.938	23.83	.125	3.18	.105	2.67
12	809-108F07	809-108V07	809-108X07	.812	20.62	.780	19.81	1.031	26.19	.125	3.18	.105	2.67

Flange Gaskets for Series 801 Mighty Mouse Receptacles

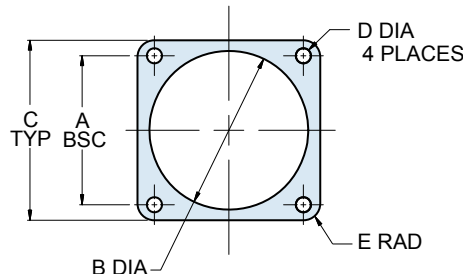
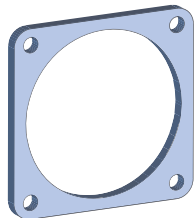

These flange gaskets provide sealing between square flange receptacles and the mounting panel. Choose fluorosilicone, Viton®, or conductive fluorosilicone material (Chomerics 1298 silver-filled). Gaskets are .032" (0.8) thick.

Shell Size	Part Number			Dimensions									
	Fluorosilicone	Viton®	Conductive Fluorosilicone	A Bsc.		B Dia.		C Typ.		D Dia.		E Rad.	
				In.	mm.	In.	mm.	In.	mm.	In.	mm.	In.	mm.
5	809-108F11	809-108V11	809-108X11	.363	9.22	.342	8.69	.530	13.46	.093	2.36	.078	1.98
6	809-108F12	809-108V12	809-108X12	.423	10.74	.405	10.29	.590	14.99	.093	2.36	.078	1.98
7	809-108F13	809-108V13	809-108X13	.483	12.27	.467	11.86	.650	16.51	.093	2.36	.078	1.98
8	809-108F14	809-108V14	809-108X14	.545	13.84	.530	13.46	.712	18.08	.093	2.36	.078	1.98
9	809-108F16	809-108V16	809-108X16	.607	15.42	.560	14.22	.850	21.59	.125	3.18	.105	2.67
10	809-108F15	809-108V15	809-108X15	.670	17.02	.655	16.64	.890	22.61	.125	3.18	.105	2.67
11	809-108F45	809-108V45	809-108X45	.715	18.16	.717	18.21	.935	23.75	.125	3.18	.105	2.67
13	809-108F17	809-108V17	809-108X17	.812	20.62	.842	21.39	1.030	26.16	.125	3.18	.105	2.67
16	809-108F18	809-108V18	809-108X18	.607	15.42	1.030	26.16	1.219	30.96	.125	3.18	.105	2.67
17	809-108F19	809-108V19	809-108X19	.812	20.62	1.092	27.74	1.280	32.51	.125	3.18	.105	2.67
19	809-108F44	809-108V44	809-108X44	1.191	30.25	1.218	30.94	1.432	36.37	.125	3.18	.105	2.67
21	809-108F43	809-108V43	809-108X43	1.322	33.58	1.332	33.83	1.570	39.88	.125	3.18	.105	2.67

Dimensions in Inches (millimeters) are subject to change without notice.



Series 80 Mighty Mouse  
Flange Gaskets 809-108



**Flange Gaskets for Series 802 Mighty Mouse Receptacles**

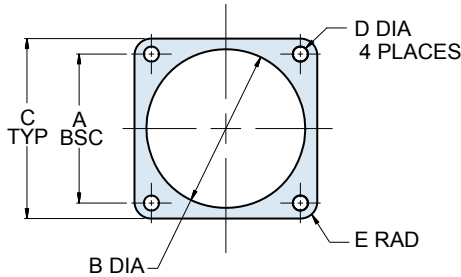
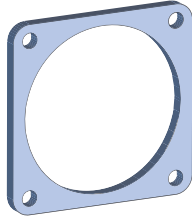

These flange gaskets provide sealing between square flange receptacles and the mounting panel. Choose fluorosilicone, Viton, or neoprene material. Gaskets are .032" (0.8) thick.

Shell Size	Part Number			Dimensions									
	Fluorosilicone	Viton®	Neoprene	A Bsc.		B Dia.		C Typ.		D Dia.		E Rad.	
				In.	mm.	In.	mm.	In.	mm.	In.	mm.	In.	mm.
5	809-108F51	809-108V51	809-108N51	.500	12.70	.448	11.38	.885	22.48	.125	3.18	.105	2.67
6	809-108F52	809-108V52	809-108N52	.625	15.88	.572	14.53	1.010	25.65	.125	3.18	.105	2.67
7	809-108F53	809-108V53	809-108N53	.688	17.48	.635	16.13	1.072	27.23	.125	3.18	.105	2.67
8	809-108F54	809-108V54	809-108N54	.750	19.05	.698	17.73	1.135	28.83	.125	3.18	.105	2.67
9	809-108F55	809-108V55	809-108N55	.812	20.62	.760	19.30	1.195	30.35	.125	3.18	.105	2.67
10	809-108F56	809-108V56	809-108N56	.875	22.23	.822	20.88	1.260	32.00	.125	3.18	.105	2.67
12	809-108F57	809-108V57	809-108N57	.938	23.83	.885	22.48	1.323	33.60	.125	3.18	.105	2.67
14	809-108F58	809-108V58	809-108N58	1.125	28.58	1.072	27.23	1.510	38.35	.125	3.18	.105	2.67
15	809-108F59	809-108V59	809-108N59	1.188	30.18	1.135	28.83	1.573	39.95	.125	3.18	.105	2.67
21	809-108F60	809-108V60	809-108N60	1.375	34.93	1.448	36.78	1.760	44.70	.125	3.18	.105	2.67

**Flange Gaskets for Series 803 Mighty Mouse Receptacles**

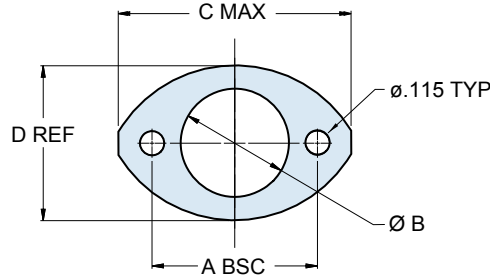
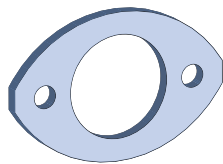

These flange gaskets provide sealing between elliptical flange receptacles and the mounting panel. Choose fluorosilicone, Viton®, or conductive fluorosilicone material (Chomerics 1298 silver-filled). Gaskets are .032" (0.8) thick.

Shell Size	Part Number			Dimensions							
	Fluorosilicone	Viton®	Conductive Fluorosilicone	A Bsc.		B Dia.		C Max.		D Ref.	
				In.	mm.	In.	mm.	In.	mm.	In.	mm.
5	809-108F31	809-108V31	809-108X31	.513	13.03	.345	8.00	.710	18.03	.460	11.68
6	809-108F32	809-108V32	809-108X32	.598	15.19	.405	10.29	.795	20.19	.522	13.26
7	809-108F33	809-108V33	809-108X33	.708	17.98	.475	12.07	.900	22.86	.590	14.99
8	809-108F34	809-108V34	809-108X34	.964	24.51	.545	13.84	1.160	29.46	.670	17.02
9	809-108F35	809-108V35	809-108X35	1.017	25.83	.605	15.37	1.215	30.86	.721	18.31
10	809-108F36	809-108V36	809-108X36	1.101	27.97	.682	17.32	1.295	32.89	.795	20.19
12	809-108F37	809-108V37	809-108X37	1.204	30.58	.757	19.23	1.400	35.56	.874	22.20
14	809-108F38	809-108V38	809-108X38	1.280	32.51	.910	23.11	1.555	39.50	1.050	26.67
15	809-108F39	809-108V39	809-108X39	1.370	34.80	.970	24.64	1.640	41.66	1.150	29.21

Dimensions in Inches (millimeters) are subject to change without notice.



Series 80 Mighty Mouse  
Flange Gaskets 809-108

**Flange Gaskets for Series 805 Mighty Mouse Receptacles**

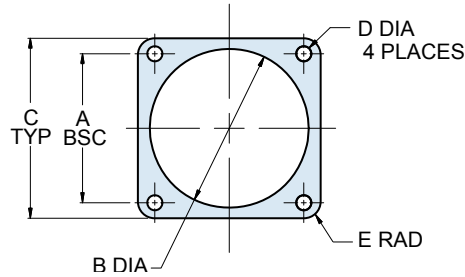
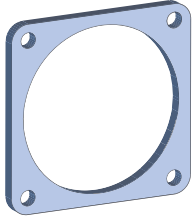

These flange gaskets provide sealing between square flange receptacles and the mounting panel. Choose fluorosilicone, Viton®, or conductive fluorosilicone material (Chomerics 1298 silver-filled). Gaskets are .032" (0.8) thick.

Shell Size	Part Number			Dimensions									
	Fluorosilicone	Viton®	Conductive Fluorosilicone	A Bsc.		B Dia.		C Typ.		D Dia.		E Rad.	
				In.	mm.	In.	mm.	In.	mm.	In.	mm.	In.	mm.
8	809-108F20	809-108V20	809-108X20	.660	16.76	.530	13.46	.850	21.59	.093	2.36	.078	1.98
9	809-108F21	809-108V21	809-108X21	.723	18.36	.590	14.99	.913	23.19	.093	2.36	.078	1.98
10	809-108F22	809-108V22	809-108X22	.785	19.94	.660	16.76	.975	24.77	.093	2.36	.078	1.98
11	809-108F23	809-108V23	809-108X23	.848	21.54	.720	18.29	1.039	26.39	.093	2.36	.078	1.98
12	809-108F24	809-108V24	809-108X24	.909	23.09	.780	19.81	1.099	27.91	.093	2.36	.078	1.98
13	809-108F29	809-108V29	809-108X29	.973	24.71	.842	21.39	1.163	29.54	.093	2.36	.078	1.98
15	809-108F25	809-108V25	809-108X25	1.058	26.87	.970	24.64	1.288	32.72	.125	3.18	.105	2.67
18	809-108F26	809-108V26	809-108X26	1.255	31.88	1.160	29.46	1.475	37.47	.125	3.18	.105	2.67
19	809-108F27	809-108V27	809-108X27	1.327	33.71	1.220	30.99	1.537	39.04	.125	3.18	.105	2.67
21	809-108F30	809-108V30	809-108X30	1.452	36	1.342	34.09	1.663	42.24	.125	3.18	.105	2.67
23	809-108F28	809-108V28	809-108X28	1.570	39.88	1.458	37.03	1.797	45.64	.125	3.18	.105	2.67

Dimensions in Inches (millimeters) are subject to change without notice.



### What is outgassing?

Plastic and rubber materials give off gaseous molecules. For example, the smell inside a new car is caused by polymer outgassing. Heat and vacuum increase the rate of diffusion. In a spacecraft the gases coming off polymers can contaminate optical surfaces and instruments. The result is degraded performance.

### How is outgassing measured?

The space industry has adopted a standardized test procedure, **ASTM E 595**, to evaluate out-gassing properties of polymers. Small samples of material are heated to 125° C. at a vacuum of  $5 \times 10^{-5}$  torr for 24 hours. Then the sample is weighed to calculate the **Total Mass Loss** (TML). The TML cannot exceed 1.00% of the total initial mass. During the test, outgassed matter condenses on a cooled collector plate. The quantity of outgassed matter is calculated to determine the **Collected Volatile Condensable Material** (CVCN). The CVCN cannot exceed 0.10% of the original specimen mass.

### What is NASA screening?

NASA specification EEE-INST-002 provides instructions on selecting, screening and qualifying parts for use on NASA GSFC space flight projects.

### What screening level is required?

NASA defines three levels of screening: level 1 for highest reliability, level 2 for high reliability, and level 3 for standard reliability. Level 3 equates to standard lot acceptance inspection. Levels 1 and 2 call for additional testing.

## HOW TO ORDER SPACE GRADE CONNECTORS

### Step 1: Find a Standard Part Number

Electroless nickel plated shells are preferred for space flight. Cadmium plating is prohibited.

### Step 2: Select a NASA Screening Level

The term "Screening Level" refers to the final inspection procedure.

**Level 1** for mission-critical highest reliability

**Level 2** for high reliability

**Level 3** for standard reliability

### Step 3: Choose Outgassing Processing

A detailed explanation of outgassing is on the following pages. The fluorosilicone rubber seals commonly used on aerospace-grade connectors such as MIL-DTL-38999 and Series 79 connectors, along with certain bonding agents and inks, do not meet NASA outgassing requirements unless the connector is specially processed. Glenair outgassing tests have shown oven baking or thermal vacuum outgassing processing are sufficient to reduce outgassing levels to NASA standards. Oven baking is more economical than thermal vacuum outgassing.

### Step 4: Select the Mod 429 Code that Matches the Desired Level of Screening and Outgassing

Use the following table to choose the right modification code. Add the mod code to the connector part number. Example: 790-024PC-13ML-**429C**

## NASA SCREENING LEVELS AND MODIFICATION CODES

NASA Screening Level	Special Screening Only	Special Screening Plus Outgassing Processing	
		48 Hour Oven Bake 175° C.	Thermal Vacuum Outgassing 24 hrs. 125° C.
Level 1 Highest Reliability	Mod 429B	Mod 429J	Mod 429C
Level 2 High Reliability	Mod 429	Mod 429K	Mod 429A
Level 3 Standard Reliability	(Use standard part number)	Mod 186	Mod 186M

Dimensions in Inches (millimeters) are subject to change without notice.

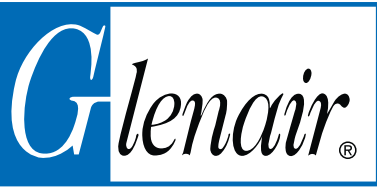

800-013  
Series 800 Mighty Mouse Hermetic Receptacles  
with UN Mating Thread  
How to Order Information



Series 800 Hermetic

**Series 800 Hermetic Receptacles** feature 304L stainless steel shells, fused vitreous glass insulators and Alloy 52 iron alloy contacts.

**1 X 10<sup>-7</sup> cc/second** maximum helium leak rate.

**Three Shell Styles:** solder mount, jam nut or square flange.

**Solder Cup Contacts** for wire attachment, or **PC Tail Contacts** for attachment to flexible or rigid circuits.

C

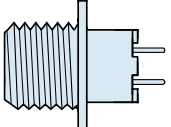
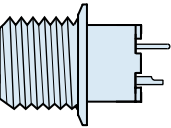
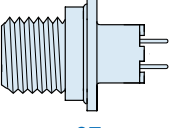
HOW TO ORDER					
Sample Part Number					
800-013	-07	Z1	7-10	P	Z
Series	Shell Style	Shell Material / Finish	Shell Size- Insert Arrangement	Contact Type	Shell Key Position
<b>800-013</b> Hermetic Receptacle	 <b>-02</b> Square Flange	<b>Z1</b> Stainless Steel / Passivated  <b>ZL</b> Stainless Steel / Nickel Plated  *Titanium and Inconel® shell materials are available. Consult factory for ordering information.	See Page C-4 for Contact Arrangements	<b>P</b> Pin, Solder Cup  <b>C</b> Pin, PC Tail  <b>S</b> Socket, Solder Cup  <b>D</b> Sockets, PC Tail	<b>N</b> Normal  <b>X</b> Pos. X  <b>Y</b> Pos. Y  <b>Z</b> Pos. Z
	 <b>-03</b> Solder Mount				
	 <b>-07</b> Jam Nut				

Dimensions in Inches (millimeters) are subject to change without notice.

Series 800 Mighty Mouse Hermetic Receptacles  
with UN Mating Thread  
Torque Values and Panel Cutouts



SERIES 800 RECOMMENDED TORQUE VALUES												
Shell Size	Coupling Torque				Jam Nut				Backshell			
	In-Lbs.		N-m		In-Lbs.		N-m		In-Lbs.		N-m	
	Min.	Max.	Min.	Max.	Min.	Max.	Min.	Max.	Min.	Max.	Min.	Max.
5	13	17	1.5	1.9	20	25	2.2	2.8	13	17	1.5	1.9
6	18	22	2.0	2.5	20	25	2.2	2.8	18	22	2.0	2.5
7	20	25	2.3	2.8	20	25	2.2	2.8	30	40	3.4	4.5
8	30	40	3.4	4.5	20	25	2.2	2.8	30	40	3.4	4.5
9	30	40	3.4	4.5	25	30	2.8	3.3	35	45	4.0	5.1
10	35	45	4.0	5.1	25	30	2.8	3.3	35	45	4.0	5.1
12	35	45	4.0	5.1	25	30	2.8	3.3	35	45	4.0	5.1

HERMETIC LEAK RATE MOD CODES	
Designator	Required Leak Rate
-585A	1 x 10 <sup>-10</sup> cc Helium per second
-585B	1 x 10 <sup>-9</sup> cc Helium per second
-585C	1 x 10 <sup>-8</sup> cc Helium per second

SERIES 800 PANEL CUTOUTS				
Shell Size	A Flat		øB	
	In.	mm.	In.	mm.
5	.302 / .298	7.67 / 7.57	.318	8.08
6	.365 / .361	9.27 / 9.17	.386	9.80
7	.424 / .420	10.77 / 10.67	.449	11.40
8	.486 / .482	12.34 / 12.24	.510	12.95
9	.543 / .539	13.79 / 13.69	.574	14.58
10	.617 / .613	15.67 / 15.57	.635	16.12
12	.725 / .721	18.42 / 18.31	.760	19.30

Dimensions in Inches (millimeters) are subject to change without notice.



800-013-02 and 800-013-03  
Series 800 Mighty Mouse Hermetic Receptacles  
Square Flange Mount with UN Mating Thread  
Connector Dimensions

800-013-02 Square Flange Dimensions

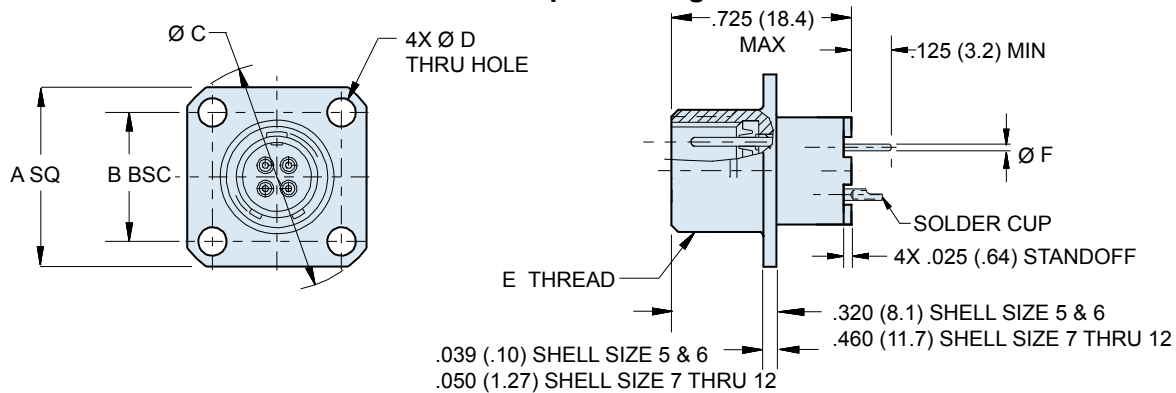

800-013-02 SQUARE FLANGE HERMETIC RECEPTACLE DIMENSIONS

Shell Size	A SQ		B BSC		Ø C		Ø D		E Threads Mating	Ø F PC TAIL DIA. ± .002 (0.05)
	In.	mm.	In.	mm.	In.	mm.	In. ± .005	mm. ± 0.13		
5	.527	13.39	.363	9.22	.680	17.27	.094	2.39	.3125-28 UN-2A	Size #23 .020 (0.51) Size #20 .026 (0.66) Size #16 .062 (1.57) Size #12 .094 (2.34)
6	.588	14.92	.423	10.74	.750	19.05			.5000-32 UN-2A	
7	.650	16.51	.483	12.27	.830	21.08	.096	2.44	.4375-28 UNEF-2A	
8	.710	18.03	.542	13.77	.938	23.83	.091	2.31	.5000-32 UN-2A	
9	.938	23.83	.719	18.26	1.250	31.75			.5625-32 UN-2A	
10	.938	23.83	.719	18.26	1.250	31.75	.130	3.30	.6250-32 UN-2A	
12	1.031	26.19	.812	20.62	1.375	34.93			.7500-28 UN-2A	

800-013-03 Solder Mount Dimensions

Shell Size 5 and 6

Shell Size 7 thru 12

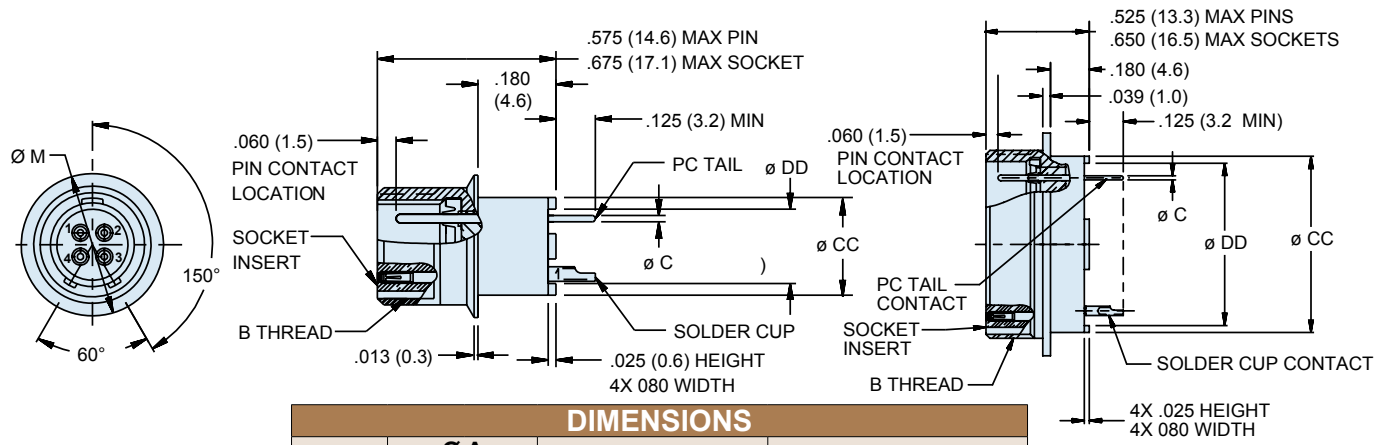

DIMENSIONS

Shell Size	Ø A		B Threads	Ø C PC TAIL DIA. ± .002 (0.05)
	In.	mm.		
5	.400	10.16	.3125-28 UN-2A	Size #22 .020 (0.51) Size #20 .026 (0.66) Size #16 .062 (1.57) Size #12 .094 (2.34)
6	.455	11.56	.3750-28 UN-2A	
7	.520	13.21	.4375-28 UNEF-2A	
8	.650	16.51	.5000-32 UN-2A	
9	.764	19.41	.5625-32 UN-2A	
10	.775	19.69	.6250-32 UN-2A	
12	.858	21.79	.7500-28 UN-2A	

Dimensions in Inches (millimeters) are subject to change without notice.

800-013-07

**Series 800 Mighty Mouse Hermetic Receptacles**  
**Jam Nut Mount with UN Mating Thread**  
**Hermetic Connector Dimensions**



Series 80  
Mighty Mouse

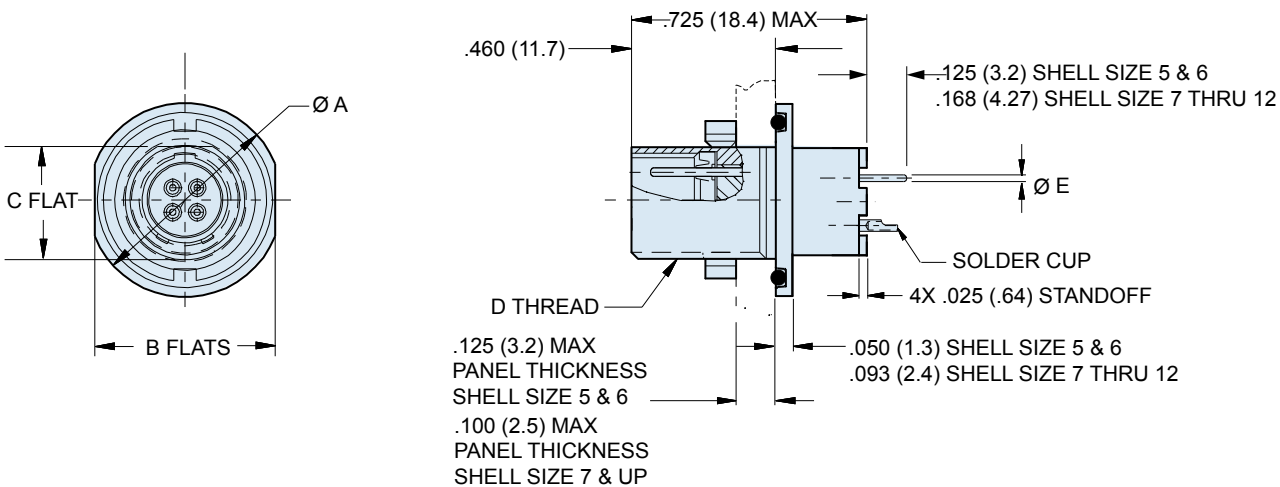

C

DIMENSIONS								
Shell Size	$\text{Ø A}$		B FLATS		C		D Threads Mating	$\text{Ø E}$ PC TAIL DIA. $\pm .002$ (0.05)
	In.	mm.	In.	mm.	In.	mm.		
5	.541	13.74	.500	12.70	.285	7.24	.3125-28 UN-2A	<b>Size #23</b> .020 (0.51) <b>Size #20</b> .026 (0.66) <b>Size #16</b> .062 (1.57) <b>Size #12</b> .094 (2.34)
6	.610	15.49	.562	14.27	.352	8.94	.3750-28 UN-2A	
7	.670	17.02	.635	16.13	.411	10.44	.4375-28 UNEF-2A	
8	.775	19.69	.735	18.67	.473	12.01	.5000-32 UN-2A	
9	.875	22.23	.806	20.47	.530	13.46	.5625-32 UN-2A	
10	.980	24.89	.940	23.88	.604	15.34	.6250-32 UN-2A	
12	1.062	26.97	.986	25.04	.712	18.08	.7500-28 UN-2A	

SERIES 800 KEY POSITIONS	
<b>Plug</b>	<b>Receptacle</b>
Key Position	Key Rotation
Normal (N)	150°
X	140°
Y	130°
Z	120°
Shell size 5 and 6: master key is located at top dead center for normal (N) position. Shell size 7 thru 12: master key is rotated 90° from TDC.	

SERIES 800 PANEL CUTOUTS				
Shell Size	A Flat		$\text{ØB}$	
	In.	mm.	In.	mm.
5	.302 / .298	7.67 / 7.57	.318	8.08
6	.365 / .361	9.27 / 9.17	.386	9.80
7	.424 / .420	10.77 / 10.67	.449	11.40
8	.486 / .482	12.34 / 12.24	.510	12.95
9	.543 / .539	13.79 / 13.69	.574	14.58
10	.617 / .613	15.67 / 15.57	.635	16.12
12	.725 / .721	18.42 / 18.31	.760	19.30

Dimensions in Inches (millimeters) are subject to change without notice.

© 2013 Glenair, Inc.

U.S. CAGE Code 06324

Printed in U.S.A.





801-012

**Series 801 Mighty Mouse Hermetic Receptacle  
Double-Start ACME Threads How to Order Information**

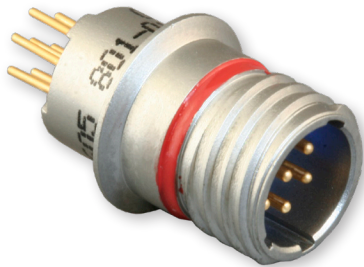

**Series 801 Hermetic Receptacles** feature 304L stainless steel shells, fused vitreous glass insulators and Alloy 52 iron alloy contacts.



**1 X 10<sup>-7</sup> cc/second** maximum helium leak rate.

**Four Shell Styles:** solder mount, jam nut, square flange or weld Mount.

**Solder Cup Contacts** or **PC Tail Contacts** for attachment to flexible or rigid circuits or rigid boards.

C

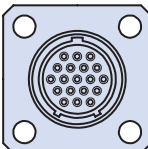
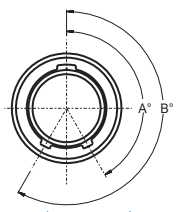
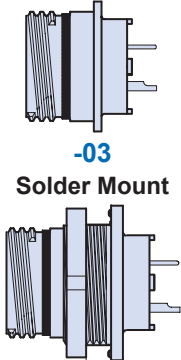
**Series 801 Solder Mount Hermetic**

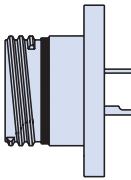
HOW TO ORDER																										
Sample Part Number																										
801-012	-03	Z1	7-10	P	A																					
Series	Shell Style	Shell Material / Finish	Shell Size/Insert Arrangement	Contact Type	Shell Key Position																					
<b>801-012</b> Hermetic Receptacles with Printed Circuit Board Contacts or Solder Cup Contacts	 <b>-02</b> Square Flange	<b>Z1</b> Stainless Steel / Passivated  <b>ZL</b> Stainless Steel / Nickel Plated  *Titanium and Inconel® shell materials are available. Consult factory for ordering information.	See Page C-4 for Contact Arrangements	<b>P</b> Pin, Solder Cup  <b>C</b> Pin, PC Tail  <b>S</b> Socket, Solder Cup  <b>D</b> Sockets, PC Tail	<b>A</b> Normal <b>B</b> Pos. B <b>C</b> Pos. C <b>D</b> Pos. D <b>E</b> Pos. E <b>F</b> Pos. F  																					
	 <b>-03</b> Solder Mount																									
	 <b>-07</b> Jam Nut																									
	 <b>-13</b> Weld Mount																									
					<table border="1"> <thead> <tr> <th></th> <th>A°</th> <th>B°</th> </tr> </thead> <tbody> <tr> <td>A</td> <td>150°</td> <td>210°</td> </tr> <tr> <td>B</td> <td>75°</td> <td>210°</td> </tr> <tr> <td>C</td> <td>95°</td> <td>230°</td> </tr> <tr> <td>D</td> <td>140°</td> <td>275°</td> </tr> <tr> <td>E</td> <td>75°</td> <td>275°</td> </tr> <tr> <td>F</td> <td>95°</td> <td>210°</td> </tr> </tbody> </table>		A°	B°	A	150°	210°	B	75°	210°	C	95°	230°	D	140°	275°	E	75°	275°	F	95°	210°
	A°	B°																								
A	150°	210°																								
B	75°	210°																								
C	95°	230°																								
D	140°	275°																								
E	75°	275°																								
F	95°	210°																								

Dimensions in Inches (millimeters) are subject to change without notice.

801-012-02

Series 801 Mighty Mouse Hermetic Receptacles  
 Double-Start ACME Threads • Square Flange  
 Connector Dimensions



Series 80  
 Mighty Mouse

HERMETIC LEAK RATE MOD CODES	
Designator	Required Leak Rate
-585A	1 x 10 <sup>-10</sup> cc Helium per second
-585B	1 x 10 <sup>-9</sup> cc Helium per second
-585C	1 x 10 <sup>-8</sup> cc Helium per second

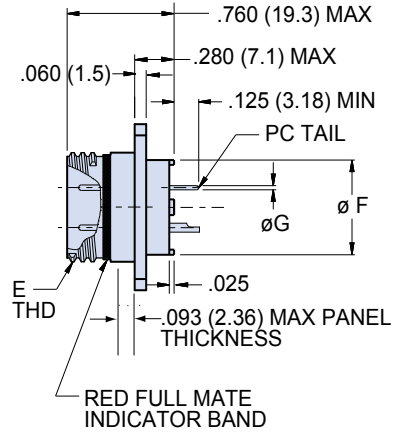
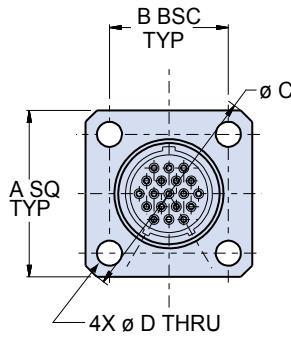

C

DIMENSIONS												
Shell Size	A SQ		B BSC		Ø C		Ø D		E Thread	Ø F		Ø G Tail Dia
	In.	mm.	In.	mm.	In.	mm.	In. ±.003	mm. ± 0.08		In.	mm.	
5	.530	13.46	.363	9.22	.680	17.27	.093	2.36	.3125-.05P-.1L-2A	.244	6.20	#23 .018/.022 (0.46/0.56)
6	.590	14.99	.423	10.74	.750	19.05	.093	2.36	.375-.05P-1L-2A	.330	8.38	
7	.650	16.51	.483	12.27	.850	21.59	.093	2.36	.4375-.05P-1L2A	.432	10.97	
8	.712	18.08	.545	13.84	.938	23.83	.093	2.36	.5000-.05P-1L2A	.493	12.52	
9	.850	21.59	.607	15.42	1.125	28.58	.128	3.25	.5625-.05P-.1L-2A	.551	14.00	#16 .060/.064 (1.52/1.63)
10	.890	22.61	.670	17.02	1.188	30.18	.128	3.25	.6250-.05P-1L2A	.620	15.75	
11	.935	23.75	.715	18.16	1.250	31.75	.128	3.25	.6875-.05P-1L2A	.662	16.81	
13	1.030	26.16	.812	20.62	1.375	34.93	.128	3.25	.8125-.1P-.2L-2A	.703	17.86	#12 .092/.096 (2.34/2.44)
16	1.219	31.96	.981	24.92	1.625	41.28	.128	3.25	1.000-.1P-.2L-2A	.863	21.92	
17	1.280	32.51	1.060	26.92	1.700	43.18	.128	3.25	1.062-.1P-.2L-2A	.912	23.16	
19	1.432	36.37	1.191	30.25	1.900	48.26	.128	3.25	1.1875-.1P-.2L-2A	1.018	25.86	
21	1.565	39.75	1.322	33.58	2.100	53.34	.128	3.25	1.3125-.1P-.2L-2A	1.170	29.72	

KEY POSITIONS

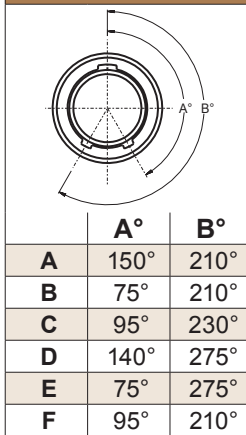

Rev. 11/15/07

Dimensions in Inches (millimeters) are subject to change without notice.

© 2013 Glenair, Inc.

U.S. CAGE Code 06324

Printed in U.S.A.



801-012-07

**Series 801 Mighty Mouse Hermetic Receptacle**  
with Double-Start ACME Threads • Jam-Nut Mount  
Connector Dimensions



Series 80  
Mighty Mouse

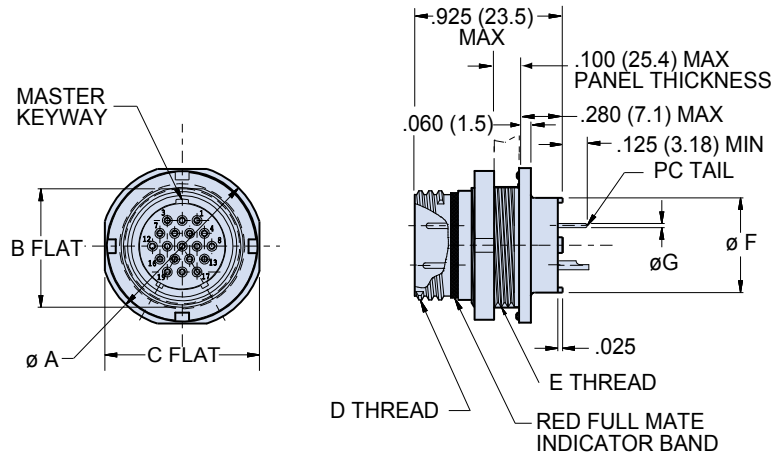

C

DIMENSIONS											
Shell Size	$\phi A$		B Flat		C Flat		D Thread	E Thread UN-2A	$\phi F$		$\phi G$ Tail Dia.
	In.	mm.	In.	mm.	In.	mm.			In.	mm.	
5	.575	14.61	.350	8.89	.545	13.84	.3125-.05P-.1L-2A	.375-28	.244	6.20	#23 .018/.022 (0.46/0.56) #20 .024/.028 (0.61/0.71) #16 .060/.064 (1.52/1.63) #12 .092/.096 (2.34/2.44)
6	.635	16.13	.410	10.41	.595	15.11	.375-.05P-.1L-2A	.4375-28	.330	8.38	
7	.755	19.18	.536	13.61	.723	18.36	.4375-.05P-.1L-2A	.5625-32	.432	10.97	
8	.755	19.18	.536	13.61	.723	18.36	.5000-.05P-.1L-2A	.5625-32	.493	12.52	
9	.830	21.08	.596	15.14	.790	20.07	.5625-.05P-.1L-2A	.625-28	.551	14.00	
10	.890	22.61	.658	16.71	.855	21.72	.6250-.05P-.1L-2A	.6875-28	.620	15.75	
11	.960	24.38	.718	18.24	.925	23.50	.6875-.05P-.1L-2A	.7500-28	.662	16.81	
13	1.078	27.38	.845	21.46	1.044	26.52	.8125-.1P-.2L-2A	.875-28	.703	17.86	
16	1.264	32.11	1.022	25.96	1.230	31.24	1.000-.1P-.2L-2A	1.0625-20	.863	21.92	
17	1.325	33.66	1.096	27.84	1.290	32.77	1.062-.1P-.2L-2A	1.1250-28	.912	23.16	
19	1.450	36.83	1.225	31.11	1.415	35.94	1.1875-.1P-.2L-2A	1.2500-28	1.018	25.86	
21	1.625	41.28	1.345	34.16	1.577	40.06	1.3125-.1P-.2L-2A	1.375-28	1.170	29.72	

KEY POSITIONS		
	A°	B°
A	150°	210°
B	75°	210°
C	95°	230°
D	140°	275°
E	75°	275°
F	95°	210°

SERIES 801 JAM NUT PANEL CUTOUT				
Shell Size	A Flat		$\phi B$	
	In. $\pm .002$	mm. $\pm 0.05$	In.	mm.
5	.356	9.04	.385	9.78
6	.416	10.57	.448	11.37
7	.542	13.77	.573	14.55
8	.542	13.77	.573	14.55
9	.602	15.29	.635	16.13
10	.666	16.92	.698	17.73
11	.726	18.44	.760	19.30
13	.851	21.62	.885	22.48
16	1.028	26.11	1.075	27.31
17	1.102	27.99	1.135	28.83
19	1.233	31.32	1.260	32.00
21	1.351	34.32	1.385	35.18

Dimensions in Inches (millimeters) are subject to change without notice.



**801-012-13**  
**Series 801 Mighty Mouse Hermetic Receptacle**  
**with Double-Start ACME Threads • Weld Mount**  
**Connector Dimensions**

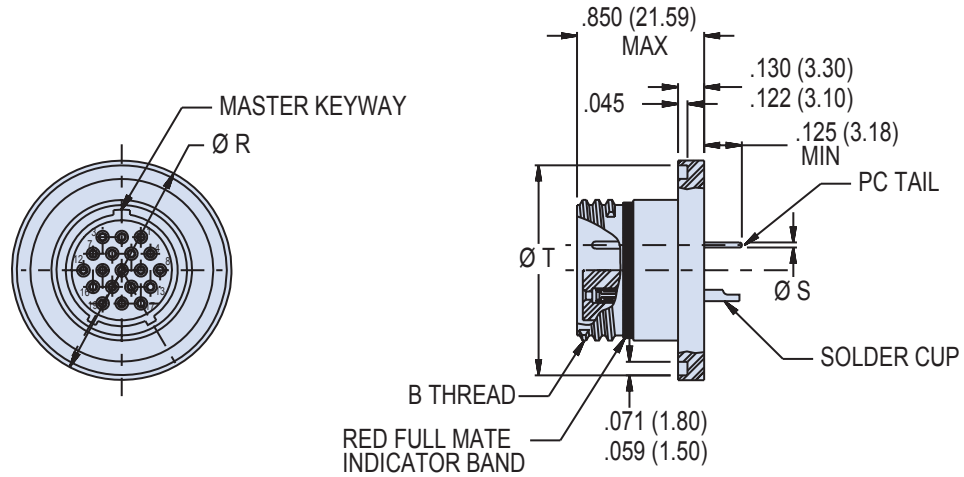

**DIMENSIONS**

Shell Size	Ø R		Ø T		Ø S Tail Dia.
	In.	mm.	In.	mm.	
5	.600	15.24	.555	14.10	<b>#23</b> .018/.022 (0.46/0.56) <b>#20</b> .024/.028 (0.61/0.71) <b>#16</b> .060/.064 (1.52/1.63) <b>#12</b> .092/.096 (2.34/2.44)
6	.665	16.89	.620	15.75	
7	.730	18.54	.685	17.40	
8	.788	20.02	.745	18.92	
9	.912	23.16	.869	22.07	
10	.975	24.77	.933	23.70	
11	1.062	26.97	1.019	25.88	
13	1.162	29.51	1.119	28.42	
16	1.288	32.72	1.245	31.62	
17	1.360	34.54	1.315	33.40	
19	1.495	37.97	1.452	36.88	
21	1.625	41.28	1.580	40.13	

**KEY POSITIONS**

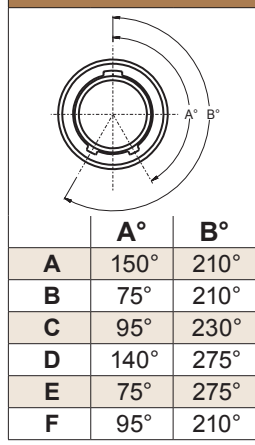

**SERIES 801 WELD MOUNT PANEL CUTOUT**

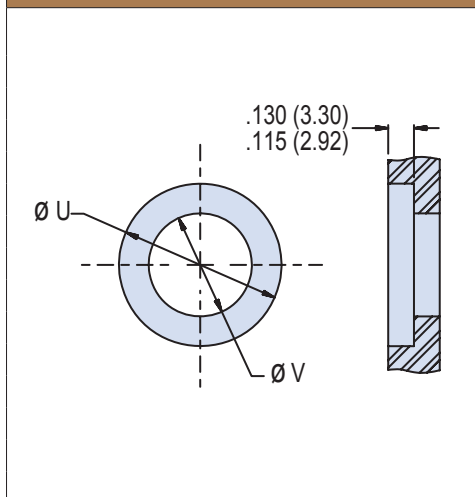

Shell Size	Ø U		Ø V Min	
	In. ± .002	mm. ± 0.05	In.	mm.
5	.606	15.39	.180	4.57
6	.671	17.04	.240	6.10
7	.736	18.69	.330	8.38
8	.794	20.17	.390	9.91
9	.918	23.32	.455	11.56
10	.981	24.92	.520	13.21
11	1.068	27.13	.580	14.73
13	1.168	29.67	.610	15.49
16	1.294	32.87	.775	19.69
17	1.366	34.70	.825	20.96
19	1.501	38.13	.930	23.62
21	1.631	41.43	1.080	27.43

Dimensions in Inches (millimeters) are subject to change without notice.

801-059

**Series 801 Mighty Mouse Hermetic Receptacle**  
 Quick Coupling • Co-Ax Pins  
 How to Order Information



Series 80  
Mighty Mouse



**Series 801 Hermetic Receptacles** feature 304L stainless steel shells, fused vitreous glass insulators and Alloy 52 iron alloy contacts.

**1 X 10<sup>-7</sup> cc/second** maximum helium leak rate.

**Three Shell Styles:** solder mount, jam nut or square flange.

**Cable Adapters with Crimp Rings** provided with each connector for reliable cable termination.

C

**Series 801 Solder Mount Hermetic**

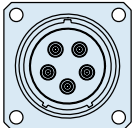
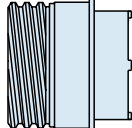
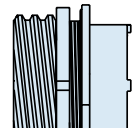
HOW TO ORDER						
Sample Part Number						
801-059	-03	Z1	16-5	P	A	-02
Series	Shell Style	Shell Material / Finish	Shell Size/Insert Arrangement	Contact Type	Shell Key Position	Cable Attachment
<b>801-059</b> Hermetic Receptacle, Quick Coupling, Co-Ax Pins	 <b>-02</b> Square Flange	<b>Z1</b> Stainless Steel / Passivated	See Page C-4 for Contact Arrangements	<b>P</b> Co-Ax Pin	<b>A</b> Normal <b>B</b> Pos. B <b>C</b> Pos. C <b>D</b> Pos. D <b>E</b> Pos. E <b>F</b> Pos. F	<b>Cables Accommodated:</b> <b>-01</b> M17/113-RG316 <b>-02</b> M17/152-00001 (RG316DS) <b>-03</b> M17/93-RG178 <b>-04</b> RG-178 Double Shield per DSCC 06017 <b>-05</b> M17/94-RG179
	 <b>-03</b> Solder Mount	<b>ZB</b> Stainless Steel / Olive Drab Chromate over Cadmium				
	 <b>-07</b> Jam Nut Rear Mount Only	<b>ZC</b> Stainless Steel / Zinc Cobalt Alloy/Black Chromate				
		<b>ZL</b> Stainless Steel / Nickel Plated  *Titanium and Incone <sup>l</sup> ® shell materials are available. Consult factory for ordering information.				

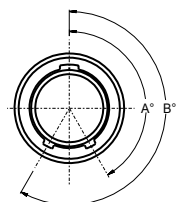

	A°	B°
A	150°	210°
B	75°	210°
C	95°	230°
D	140°	275°
E	75°	275°
F	95°	210°

**Note:**  
 Each connector is supplied with sufficient cable adapters and crimp rings to terminate appropriate cable for insertion into contact rear. After cable is terminated and adapter inserted into contact rear, the rear of the connector must be potted to cover adapters.

Dimensions in Inches (millimeters) are subject to change without notice.



**801-059-02**  
**Series 801 Mighty Mouse Hermetic Receptacle**  
 Quick Coupling • Square Flange • Co-Ax Pins  
**Connector Dimensions**

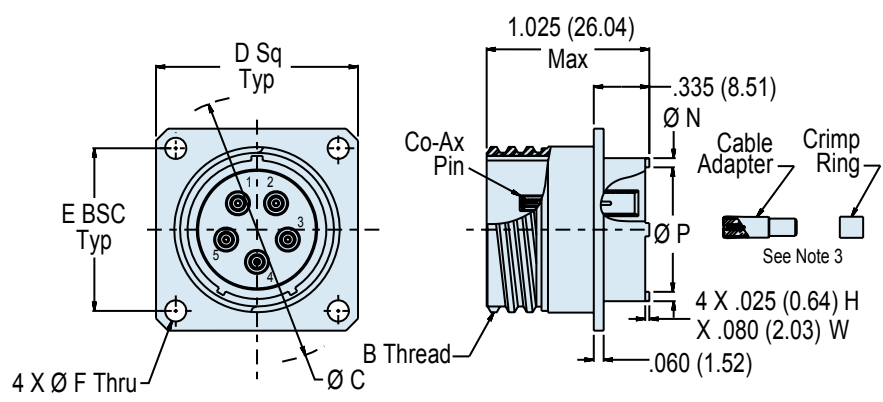

**Square Flange Panel Mount Hermetic**  
 801-059-02

DIMENSIONS									
Shell Size	B Thread	Ø C		D Sq		Ø N		Ø P	
		In.	mm.	In.	mm.	In.	mm.	In.	mm.
				±.003	± 0.08				
6	.3750-.05P-.1L-2A	.750	19.05	.590	14.99	.330	8.38	.236	6.20
7	.4375-.05P-.1L-2A	.850	21.59	.650	16.51	.432	10.97	.324	8.38
8	.5000-.05P-.1L-2A	.938	23.83	.712	18.08	.493	12.52	.390	10.97
9	.5625-.05P-.1L-2A	1.125	28.56	.850	21.59	.551	14.00	.444	12.52
10	.6250-.05P-.1L-2A	1.188	30.18	.890	22.61	.620	15.75	.520	14.00
11	.6875-.05P-.1L-2A	1.250	31.75	.935	23.75	.662	16.81	.557	15.75
13	.8125-.1P-.2L-2A	1.375	34.93	1.030	26.16	.703	17.86	.596	17.86
16	1.0000-.1P-.2L-2A	1.625	41.28	1.219	30.96	.863	21.92	.756	21.92
17	1.0625-.1P-.2L-2A	1.700	43.18	1.280	32.51	.912	23.16	.805	23.16
19	1.8750-.1P-.2L-2A	1.900	48.26	1.432	36.37	1.018	25.86	.910	29.72
21	1.3125-.1P-.2L-2A	2.100	53.34	1.565	39.75	1.170	29.72	1.061	26.95

SERIES 801 PANEL CUTOUT						
Shell Size	Ø A		E BSC		Ø F	
	In.	mm.	In.	mm.	In.	mm.
6	.455	11.56	.423	9.22	.096 .091	2.44 2.31
7	.520	13.21	.483	12.27		
8	.580	14.73	.545	13.84		
9	.645	16.38	.607	15.42	.130 .126	3.30 3.20
10	.705	17.91	.670	17.02		
11	.770	19.56	.715	18.16		
13	.895	22.73	.812	20.62		
16	1.080	27.43	.981	24.92		
17	1.145	29.08	1.060	26.92		
19	1.283	32.59	1.191	30.25		
21	1.415	35.94	1.322	33.58		

KEY POSITIONS		
	A°	B°
A	150°	210°
B	75°	210°
C	95°	230°
D	140°	275°
E	75°	275°
F	95°	210°

Dimensions in Inches (millimeters) are subject to change without notice.



801-059-03

**Series 801 Mighty Mouse Hermetic Receptacle**  
 Quick Coupling • Solder Mount • Co-Ax Pins  
 Connector Dimensions



Series 80  
Mighty Mouse

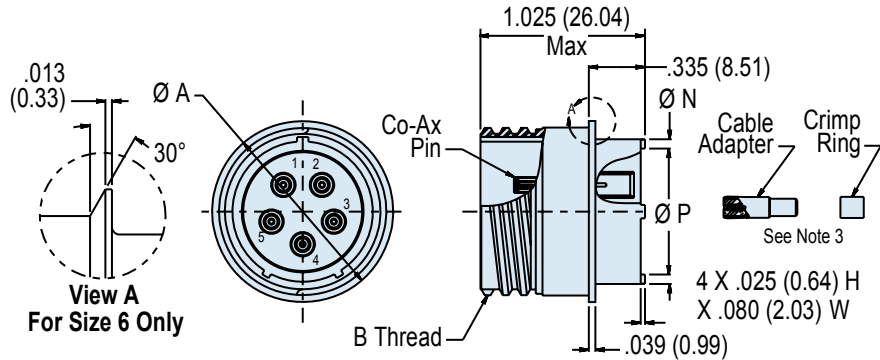

**Solder Mount Hermetic**  
 801-059-03

DIMENSIONS							
Shell Size	Ø A		B Thread	Ø N		Ø M Panel Cutout	
	In.	mm.		In.	mm.	In.	mm.
6	.455	11.56	.3750-.05P-.1L-2A	.330	8.38	.448	11.38
7	.520	13.21	.4375-.05P-.1L-2A	.432	10.97	.573	14.55
8	.580	14.73	.5000-.05P-.1L-2A	.493	12.52	.573	14.55
9	.645	16.38	.5625-.05P-.1L-2A	.551	14.00	.635	16.13
10	.705	17.91	.6250-.05P-.1L-2A	.620	15.75	.698	17.73
11	.770	19.56	.6875-.05P-.1L-2A	.662	16.81	.760	19.30
13	.895	22.73	.8125-.1P-.2L-2A	.703	17.86	.885	22.48
16	1.080	29.08	1.0000-.1P-.2L-2A	.863	21.92	1.075	27.31
17	1.145	29.08	1.0625-.1P-.2L-2A	.912	23.16	1.135	28.83
19	1.283	32.59	1.8750-.1P-.2L-2A	1.018	25.86	1.260	32.00
21	1.415	35.94	1.3125-.1P-.2L-2A	1.170	29.72	1.385	68.83

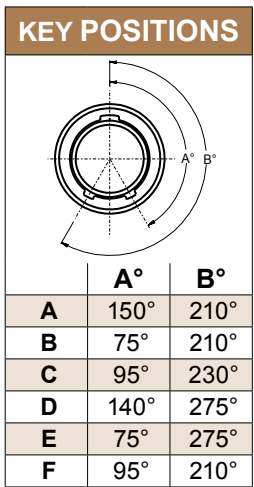

Dimensions in Inches (millimeters) are subject to change without notice.



801-059-07

Series 801 Mighty Mouse Hermetic Receptacle  
Quick Coupling, Jam Nut Mount with Co-Ax Pins

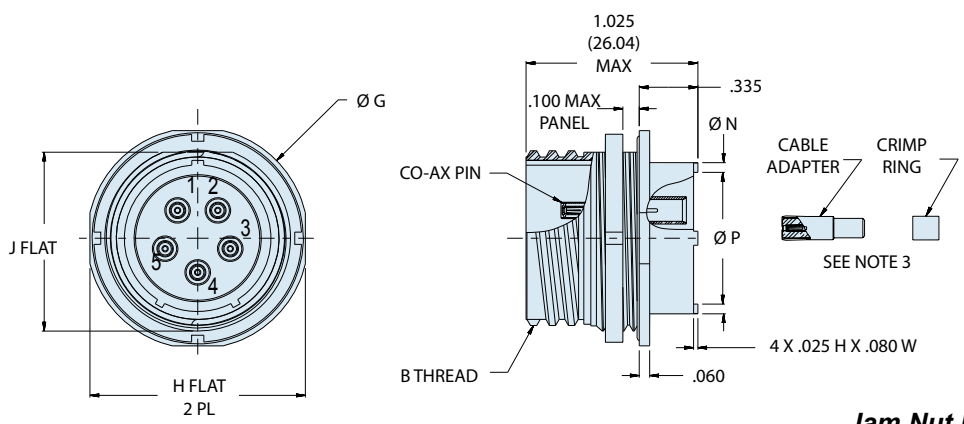

**Jam Nut Mount Hermetic**  
801-059-07

**DIMENSIONS**

Shell Size	Ø A		J Flat		H Flat		B Thread	K Thread	Ø N		Ø P	
	In.	mm.	In.	mm.	In.	mm.			In.	mm.	In.	mm.
6	.455	11.56	.410	10.41	.595	15.11	.3750-.05P-.1L-2A	.4375-28 UNEF-2A	.330	8.38	.236	5.99
7	.520	13.21	.536	13.61	.723	18.36	.4375-.05P-.1L-2A	.5625-32 UN-2A	.432	10.97	.324	8.23
8	.580	14.73	.536	13.61	.723	18.36	.5000-.05P-.1L-2A	.5625-32 UN-2A	.493	12.52	.390	9.91
9	.645	16.38	.596	15.14	.790	20.07	.5625-.05P-.1L-2A	.6250-28 UN-2A	.551	14.00	.444	11.28
10	.705	17.91	.658	16.71	.855	21.72	.6250-.05P-.1L-2A	.6875-28 UN-2A	.620	15.75	.520	13.21
11	.770	19.56	.718	18.24	.925	23.50	.6875-.05P-.1L-2A	.7500-28 UN-2A	.662	16.81	.557	14.15
13	.895	22.73	.845	21.46	1.044	26.52	.8125-.1P-.2L-2A	.8750-28 UN-2A	.703	17.86	.596	15.14
16	1.080	27.43	1.022	25.96	1.230	31.24	1.0000-.1P-.2L-2A	1.0625-20 UN-2A	.863	21.92	.756	19.20
17	1.145	29.08	1.096	27.84	1.290	32.77	1.0625-.1P-.2L-2A	1.1250-28 UN-2A	.912	23.16	.805	20.45
19	1.283	32.59	1.225	31.12	1.415	35.94	1.8750-.1P-.2L-2A	1.2500-28 UN-2A	1.018	25.86	.910	23.11
21	1.415	35.94	1.346	34.19	1.577	40.06	1.3125-.1P-.2L-2A	1.3750-28 UN-2A	1.170	29.72	1.061	26.95

**KEY POSITIONS**

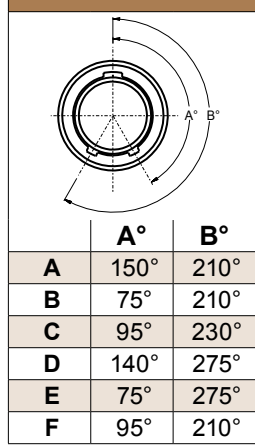

**SERIES 801 JAM NUT PANEL CUTOUT**

Shell Size	L Flat		Ø M	
	In. ± .002	mm. ± 0.05	In.	mm.
6	.418/.414	10.62/10.52	.448	11.38
7	.544/.540	13.82/13.72	.573	14.55
8	.544/.540	13.82/13.72	.573	14.55
9	.604/.600	15.34/15.24	.635	16.13
10	.668/.664	16.97/16.87	.698	17.73
11	.728/.724	18.49/18.39	.760	19.30
13	.853/.849	21.67/21.56	.885	22.48
16	1.030/1.026	26.16/26.06	1.075	27.31
17	1.104/1.100	28.04/27.94	1.135	28.83
19	1.235/1.231	31.37/31.27	1.260	32.00
21	1.353/1.349	34.37/34.26	1.385	68.83

Recommended Panel Cutout Shell Style -07

Dimensions in Inches (millimeters) are subject to change without notice.

**802-013**  
**Series 802 "Aqua Mouse" Submersible**  
**Hermetic Receptacle How to Order Information**



**Style 00 Front Mount**

**Series 802 Hermetic Receptacles** feature gold plated iron alloy contacts and compression glass dielectric material. The 316L stainless steel connector shell provides excellent corrosion protection and is suitable for e-beam welding. The Viton® interfacial seal and piston o-ring offer improved resistance to harsh chemicals.

**1 x 10<sup>-7</sup> cc/Second Maximum Helium Leak Rate.** Open face (unmated) pressure rating is 1000 PSI. When mated, Series 802 connectors withstand 3500 PSI hydrostatic pressure.

HERMETIC LEAK RATE MOD CODES	
Designator	Required Leak Rate
-585A	1 x 10 <sup>-10</sup> cc Helium per second
-585B	1 x 10 <sup>-9</sup> cc Helium per second
-585C	1 x 10 <sup>-8</sup> cc Helium per second

**HOW TO ORDER SERIES 802 HERMETIC RECEPTACLES**

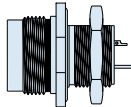
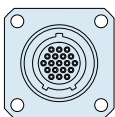
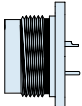
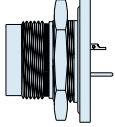
Sample Part Number					
802-013	-00	Z1	6-7	P	A
Series	Shell Style	Shell Material / Finish	Shell Size- Insert Arrangement	Contact Type	Shell Key Position
<p><b>802-013</b> Series 802 Hermetic Receptacle with Solder Cup or PCB Contacts</p>	 <p><b>-00</b> Jam Nut for Front Panel Mounting</p>  <p><b>-02</b> Square Flange Mount</p>  <p><b>-03</b> Weld Mount</p>  <p><b>-07</b> Jam Nut for Rear Panel Mounting</p>	<p><b>Z1</b> Stainless Steel / Passivated</p> <p><b>ZL</b> Stainless Steel / Nickel Plated</p> <p>*Titanium and Inconel® shell materials are available. Consult factory for ordering information.</p>	<p>See Page C-4 for Contact Arrangements</p>	<p><b>E</b> Pin, Solder Cup</p> <p><b>P</b> Pin, PC Tail</p> <p><b>S</b> Socket, Solder Cup</p> <p><b>D</b> Sockets, PC Tail</p>	<p><b>A</b> Normal</p> <p><b>B</b> Pos. B</p> <p><b>C</b> Pos. C</p> <p><b>D</b> Pos. D</p>

Dimensions in Inches (millimeters) are subject to change without notice.



802-013-00

Series 802 "Aqua Mouse" Submersible  
Hermetic Front Mount Jam Nut Receptacle  
Connector Dimensions

C

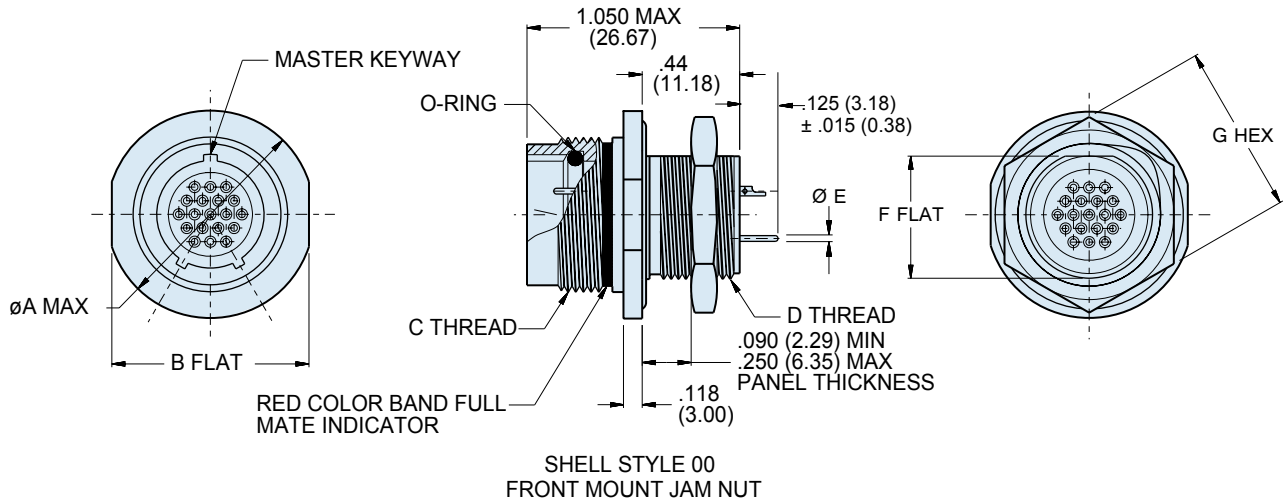

DIMENSIONS

Shell Size	A Max.		B Flat		C Mating Threads	D Threads	Ø E Tail Dia.	F Flat		G Hex	
	In.	mm.	In.	mm.				In.	mm.	In.	mm.
5	.720	18.29	.625	15.88	.438-28 UNEF-2A	.312-28 UN-2A	#23 .018/.022 (0.46/0.56)	.281	7.14	.500	12.70
6	.780	19.81	.750	19.05	.562-20 UN-2A	.438-28 UN-2A		.344	8.74	.625	15.88
7	.910	23.11	.812	20.62	.625-20 UN-2A	.500-32 UN-2A		.469	11.91	.688	17.48
8	.960	24.38	.875	22.23	.687-20 UN-2A	.562-28 UN-2A	#20 .024/.028 (0.61/0.71)	.531	13.49	.750	19.05
9	1.030	26.16	.937	23.80	.750-20 UNEF-2A	.625-20 UN-2A		.594	15.09	.812	20.62
10	1.090	27.69	1.000	25.40	.812-20 UNEF-2A	.687-28 UN-2A		.656	16.66	.875	22.23
12	1.160	29.46	1.062	26.97	.875-20 UNEF-2A	.750-28 UN-2A	#16 .060/.064 (1.52/1.63)	.719	18.26	.938	23.83
14	1.340	34.04	1.250	31.75	1.062-20 UN-2A	.938-28 UN-2A		.893	22.68	1.125	28.58
15	1.410	35.18	1.312	33.32	1.125-20 UN-2A	1.000-28 UN-2A		.955	24.26	1.188	30.18
21	1.700	43.18	1.562	39.67	1.4375-20 UN-2A	1.312-28 UN-2A	#12 .092/.096 (2.34/2.44)	1.257	31.93	1.500	38.10

SERIES 802 RECEPTACLE KEY POSITIONS

Key Position	Key Rotation	
	A°	B°
Normal (A)	150°	210°
B	75°	210°
C	95°	230°
D	140°	275°
E	75°	275°
F	95°	210°

CUTOUT DIMENSIONS

Shell Size	H Flat		Ø J	
	In.	mm.	In.	mm.
5	.291/.286	7.4/7.3	.322	8.2
6	.417/.412	10.6/10.5	.448	11.4
7	.479/.474	12.2/12.0	.510	13.0
8	.541/.536	13.7/13.6	.572	14.5
9	.604/.599	15.3/15.2	.635	16.1
10	.666/.661	16.9/16.8	.697	17.7
12	.729/.724	18.5/18.4	.760	19.3
14	.903/.898	22.9/22.8	.948	24.1
15	.965/.960	24.5/24.4	1.010	25.7
21	1.267/1.263	32.2/32.1	1.322	33.6

RECOMMENDED PANEL CUTOUT FOR STYLE 00 FRONT MOUNT JAM NUT

Dimensions in Inches (millimeters) are subject to change without notice.

802-013-02

Series 802 "Aqua Mouse" Submersible  
Square Flange Mount Hermetic Receptacle  
Connector Dimensions



Series 80  
Mighty Mouse

C

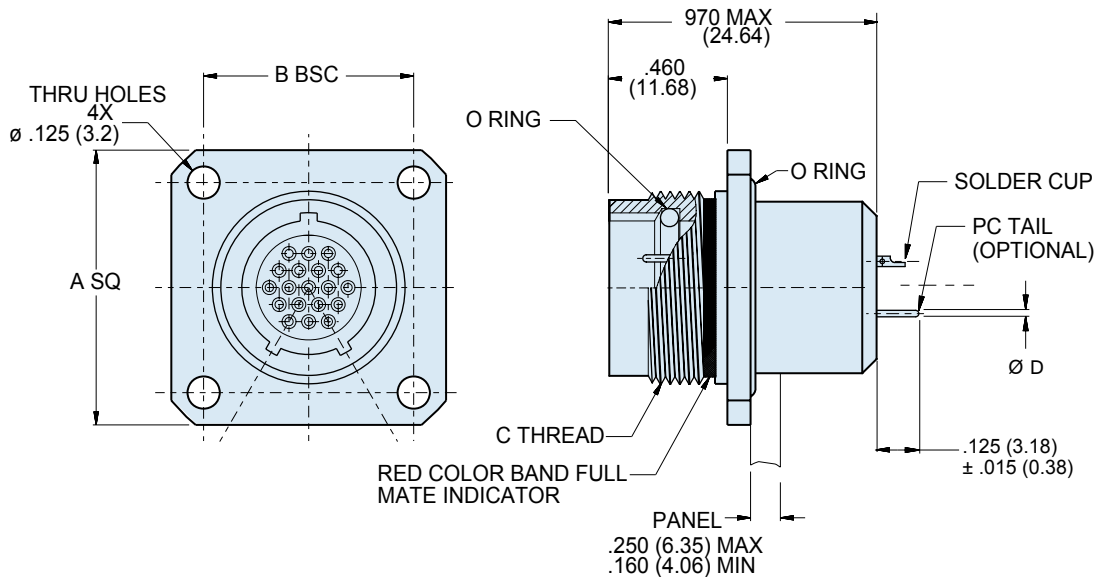

DIMENSIONS								
Shell Size	A Square		B BSC.		C Mating Threads	Ø D Tail Dia.	Ø E	
	In.	mm.	In.	mm.			In.	mm.
5	.885	22.48	.500	12.70	.438-28 UNEF	#23 .018/.022 (0.46/0.56)	.327	8.31
6	1.010	25.65	.625	15.88	.562-20 UN		.390	9.91
7	1.072	27.23	.688	17.48	.625-20 UN		.515	13.08
8	1.135	28.83	.750	19.05	.687-20 UN	#20 .024/.028 (0.61/0.71)	.577	14.66
9	1.195	30.35	.812	20.62	.750-20 UNEF		.640	16.26
10	1.260	32.00	.875	22.23	.812-20 UNEF	#16 .060/.064 (1.52/1.63)	.702	17.83
12	1.323	33.60	.938	23.83	.875-20 UNEF		.765	19.43
14	1.510	38.25	1.125	28.58	1.062-20 UN		.953	24.21
15	1.573	39.95	1.188	30.18	1.125-20 UN	#12 .092/.096 (2.34/2.44)	1.015	25.78
21	1.750	44.45	1.375	34.93	1.4375-20 UN		1.312	33.32

SERIES 802 RECEPTACLE KEY POSITIONS		
Key Position	Key Rotation	
	A°	B°
Normal (A)	150°	210°
B	75°	210°
C	95°	230°
D	140°	275°
E	75°	275°
F	95°	210°

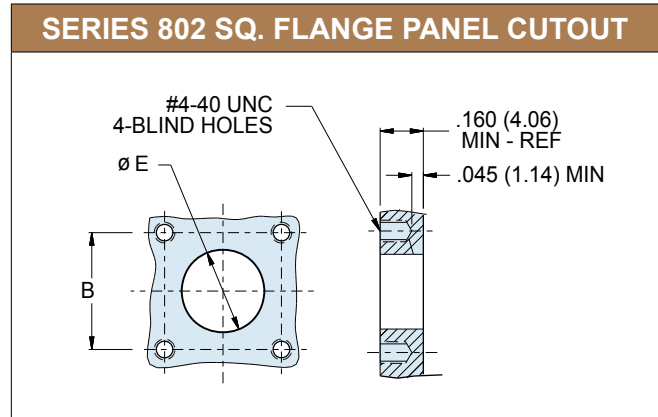

Dimensions in Inches (millimeters) are subject to change without notice.



802-013-03

Series 802 "Aqua Mouse" Submersible  
Weld Mount Hermetic Receptacle  
Connector Dimensions

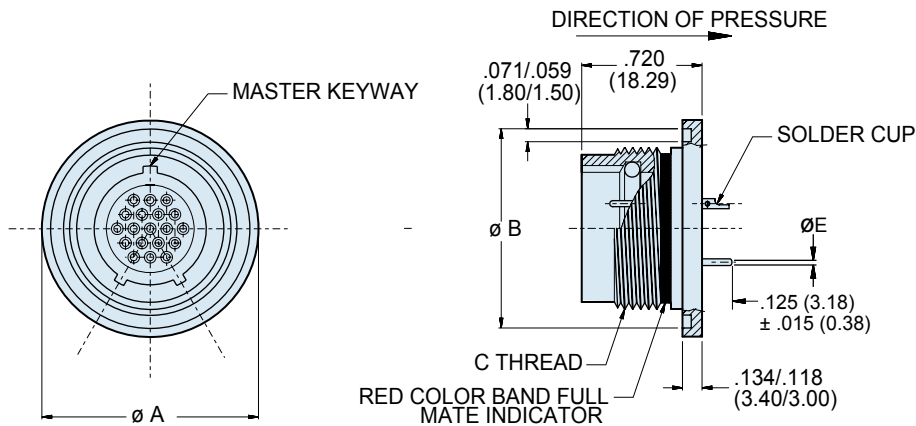

SHELL STYLE 03  
WELD MOUNT

DIMENSIONS

Shell Size	$\varnothing A$		$\varnothing B$		C Mating Threads	$\varnothing E$ Tail Dia.
	In. $\pm$ .006	mm. $\pm$ 0.15	In. $\pm$ .006	mm. $\pm$ 0.15		
5	.788	20.02	.745	18.92	.438-28 UNEF	#23 .018/.022 (0.46/0.56)
6	.912	23.16	.869	22.07	.562-20 UN	
7	.975	24.77	.933	23.70	.625-20 UN	
8	1.038	26.37	.995	25.27	.687-20 UN	#20 .024/.028 (0.61/0.71)
9	1.100	27.94	1.057	26.85	.750-20 UNEF	
10	1.162	29.53	1.119	28.42	.812-20 UNEF	#16 .060/.064 (1.52/1.63)
12	1.225	31.12	1.182	30.02	.875-20 UNEF	
14	1.412	35.86	1.369	34.77	1.062-20 UN	#12 .092/.096 (2.34/2.44)
15	1.475	37.47	1.432	36.37	1.125-20 UN	
21	1.795	45.59	1.747	44.38	1.4375-20 UN	

SERIES 802 RECEPTACLE KEY POSITIONS

Key Position	Key Rotation	
	A°	B°
Normal (A)	150°	210°
B	75°	210°
C	95°	230°
D	140°	275°
E	75°	275°
F	95°	210°

Diagram showing the key positions A and B on the receptacle. The diagram illustrates the rotation angles for each key position relative to a vertical reference line.

Dimensions in Inches (millimeters) are subject to change without notice.

802-013-07

Series 802 "Aqua Mouse" Submersible  
Hermetic Rear Mount Jam Nut Receptacle  
Connector Dimensions



Series 80  
Mighty Mouse

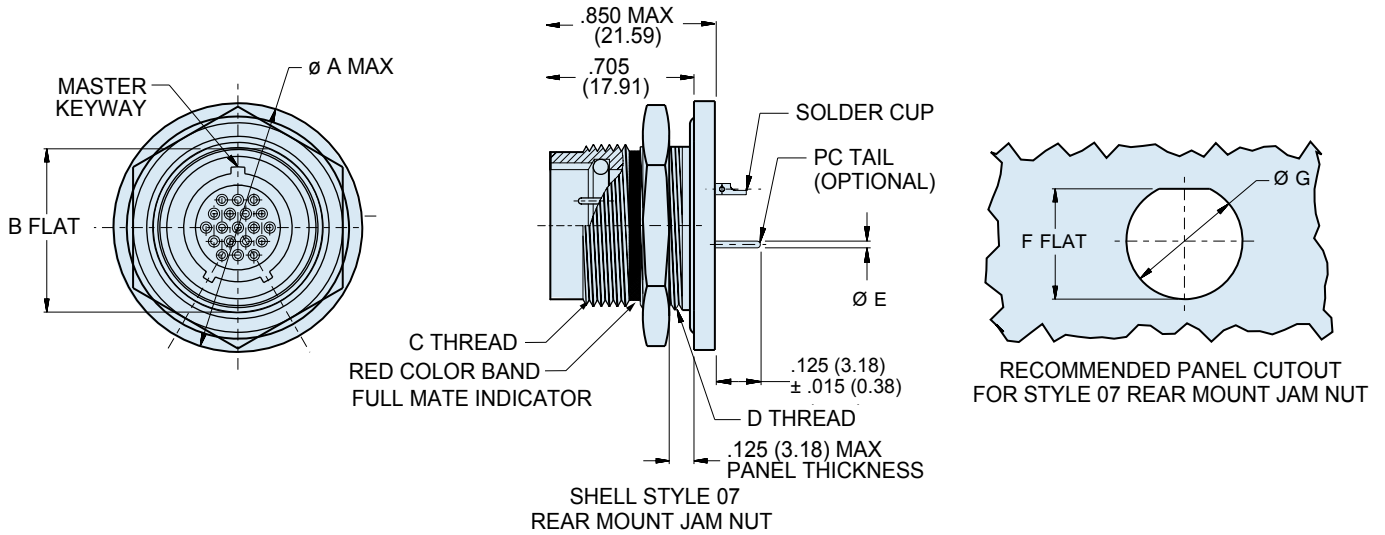

C

DIMENSIONS

Shell Size	Ø A Max.		B Flat		C Mating Threads	D Threads	Ø E Tail Dia.	F Flat		Ø G	
	In.	mm.	In. ± .003	mm. ± 0.08				In. ± .003	mm. ± 0.08	In.	mm.
5	.885	22.48	.466	11.84	.438-28 UNEF	.500-32 UN-2A	#23 .018/.022 (0.46/0.56)	.473	12.01	.510	12.95
6	1.010	25.65	.591	15.01	.562-20 UN	.625-20 UN-2A		.603	15.32	.635	16.13
7	1.072	27.23	.653	16.59	.625-20 UN	.687-28 UN-2A		.662	16.81	.697	17.70
8	1.135	28.83	.727	18.47	.687-20 UN	.750-28 UN-2A	#20 .024/.028 (0.61/0.71)	.735	18.67	.760	19.30
9	1.195	30.35	.778	19.76	.750-20 UNEF	.812-28 UN-2A		.785	19.94	.822	20.88
10	1.260	32.00	.827	21.01	.812-20 UNEF	.875-28 UN-2A	#16 .060/.064 (1.52/1.63)	.835	21.21	.885	22.48
12	1.322	33.58	.890	22.61	.875-20 UNEF	.938-28 UN-2A		.899	22.83	.948	24.08
14	1.510	38.25	1.077	27.36	1.062-20 UN	1.125-28 UN-2A	#12 .092/.096 (2.34/2.44)	1.085	27.56	1.135	28.83
15	1.572	39.93	1.140	28.96	1.125-20 UN	1.188-28 UN-2A		1.155	29.34	1.198	30.43
21	1.940	49.28	1.464	37.19	1.4375-20 UN	1.500-28 UN-2A		1.473	37.41	1.510	39.12

SERIES 802 RECEPTACLE KEY POSITIONS		
Key Position	Key Rotation	
	A°	B°
Normal (A)	150°	210°
B	75°	210°
C	95°	230°
D	140°	275°
E	75°	275°
F	95°	210°

Dimensions in Inches (millimeters) are subject to change without notice.





**802-040**  
**Series 802 "Aqua Mouse" Submersible**  
**Hermetic Receptacle How to Order Information**  
**Sizes 12 and 16 Only**



**Series 802 Hermetic Receptacles** feature 316L stainless steel shells, fused vitreous glass insulators and Alloy 52 iron alloy contacts.

**1 X 10<sup>-7</sup> cc/second** maximum helium leak rate.

**Four Shell Styles:** front mount jam nut, front panel square flange mount, weld mount and rear panel jam nut mount.

**Cable Adapters with Crimp Rings** provided with each connector for reliable cable termination.

802-040-00 Front Mount

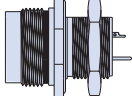
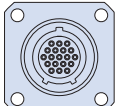
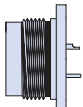
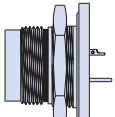
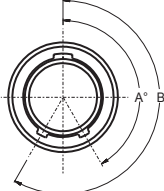
HOW TO ORDER																											
Sample Part Number																											
802-040	-07	Z1	12-3	P	A	-210																					
Series	Shell Style	Shell Material / Finish	Shell Size/ Insert Arrangement	Contact Type	Shell Key Position	Cable Style																					
<p><b>802-040</b> Hermetic Receptacle, Co-Ax Contacts, Sizes 12 and 16 Only</p>	<p><b>-00</b> Front Mount Jam Nut</p>  <p><b>-02</b> Front Panel Square Flange Mount</p>  <p><b>-03</b> Weld Mount</p>  <p><b>-07</b> Rear Panel Jam Nut Mount</p> 	<p><b>Z1</b> Stainless Steel / Passivated</p> <p><b>ZL</b> Stainless Steel / Nickel Plated</p> <p>Titanium and Incone<sup>®</sup> shell materials are available. Consult factory for ordering information.</p>	<p>See Page C-4 for Contact Arrangements</p>	<p><b>P</b> Co-Ax Pin</p> <p><b>S</b> Co-Ax Socket</p>	<p><b>A</b> Normal</p> <p><b>B</b> Pos. B</p> <p><b>C</b> Pos. C</p> <p><b>D</b> Pos. D</p> <p><b>E</b> Pos. E</p> <p><b>F</b> Pos. F</p>  <table border="1" style="margin-left: auto; margin-right: auto;"> <thead> <tr> <th></th> <th style="text-align: center;">A°</th> <th style="text-align: center;">B°</th> </tr> </thead> <tbody> <tr> <td style="text-align: center;"><b>A</b></td> <td style="text-align: center;">150°</td> <td style="text-align: center;">210°</td> </tr> <tr> <td style="text-align: center;"><b>B</b></td> <td style="text-align: center;">75°</td> <td style="text-align: center;">210°</td> </tr> <tr> <td style="text-align: center;"><b>C</b></td> <td style="text-align: center;">95°</td> <td style="text-align: center;">230°</td> </tr> <tr> <td style="text-align: center;"><b>D</b></td> <td style="text-align: center;">140°</td> <td style="text-align: center;">275°</td> </tr> <tr> <td style="text-align: center;"><b>E</b></td> <td style="text-align: center;">75°</td> <td style="text-align: center;">275°</td> </tr> <tr> <td style="text-align: center;"><b>F</b></td> <td style="text-align: center;">95°</td> <td style="text-align: center;">210°</td> </tr> </tbody> </table>		A°	B°	<b>A</b>	150°	210°	<b>B</b>	75°	210°	<b>C</b>	95°	230°	<b>D</b>	140°	275°	<b>E</b>	75°	275°	<b>F</b>	95°	210°	<p>Specify BIN Code per AS39029/27, /28, /76 and /78</p> <p><b>Note:</b> Each connector is supplied with sufficient cable adapters and crimp rings to terminate appropriate cable for insertion into contact rear. After cable is terminated and adapter inserted into contact rear, the rear of the connector must be potted to cover adapters.</p>
	A°	B°																									
<b>A</b>	150°	210°																									
<b>B</b>	75°	210°																									
<b>C</b>	95°	230°																									
<b>D</b>	140°	275°																									
<b>E</b>	75°	275°																									
<b>F</b>	95°	210°																									

Dimensions in Inches (millimeters) are subject to change without notice.

802-040-00

Series 802 "Aqua Mouse" Submersible  
Co-Ax Contacts • Sizes 12 and 16 Only  
Front Panel Jam Nut Mount Hermetic Receptacle



Series 80  
Mighty Mouse

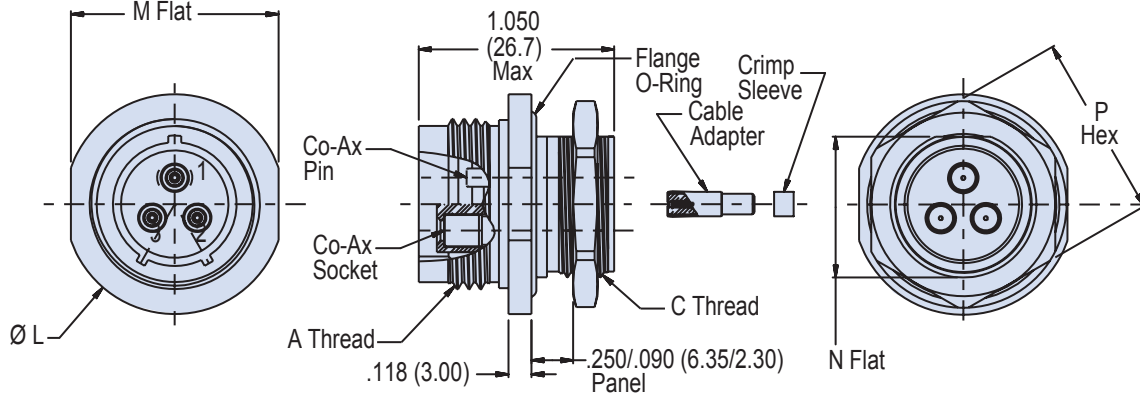

Front Panel Jam Nut Mount Submersible Hermetic  
802-040-00

DIMENSIONS

Shell Size	L Max.		M Flat		A Mating Threads	C Threads	N Flat		P Hex	
	In.	mm.	In.	mm.			In.	mm.	In.	mm.
5	.720	18.29	.625	15.88	.438-28 UNEF-2A	.312-28 UN-2A	.281	7.14	.500	12.70
6	.780	19.81	.750	19.05	.562-20 UN-2A	.438-28 UN-2A	.344	8.74	.625	15.88
7	.910	23.11	.812	20.62	.625-20 UN-2A	.500-32 UN-2A	.469	11.91	.688	17.48
8	.960	24.38	.875	22.23	.687-20 UN-2A	.562-28 UN-2A	.531	13.49	.750	19.05
9	1.030	26.16	.937	23.80	.750-20 UNEF-2A	.625-20 UN-2A	.594	15.09	.812	20.62
10	1.090	27.69	1.000	25.40	.812-20 UNEF-2A	.687-28 UN-2A	.656	16.66	.875	22.23
12	1.160	29.46	1.062	26.97	.875-20 UNEF-2A	.750-28 UN-2A	.719	18.26	.938	23.83
14	1.340	34.04	1.250	31.75	1.062-20 UN-2A	.938-28 UN-2A	.893	22.68	1.125	28.58
15	1.410	35.18	1.312	33.32	1.125-20 UN-2A	1.000-28 UN-2A	.955	24.26	1.188	30.18
21	1.700	43.18	1.562	39.67	1.4375-20 UN-2A	1.312-28 UN-2A	1.257	31.93	1.500	38.10

SERIES 802 RECEPTACLE KEY POSITIONS

Key Position	Key Rotation	
	A°	B°
Normal (A)	150°	210°
B	75°	210°
C	95°	230°
D	140°	275°
E	75°	275°
F	95°	210°

CUTOUT DIMENSIONS

Shell Size	H Flat		Ø J	
	In.	mm.	In.	mm.
5	.291/.286	7.4/7.3	.322	8.2
6	.417/.412	10.6/10.5	.448	11.4
7	.479/.474	12.2/12.0	.510	13.0
8	.541/.536	13.7/13.6	.572	14.5
9	.604/.599	15.3/15.2	.635	16.1
10	.666/.661	16.9/16.8	.697	17.7
12	.729/.724	18.5/18.4	.760	19.3
14	.903/.898	22.9/22.8	.948	24.1
15	.965/.960	24.5/24.4	1.010	25.7
21	1.267/1.263	32.2/32.1	1.322	33.6

Dimensions in Inches (millimeters) are subject to change without notice.



**802-040-02**  
**Series 802 "Aqua Mouse" Submersible**  
**Coax Contacts • Sizes 12 and 16 Only**  
**Front Panel Square Flange Mount Hermetic Receptacle**

C

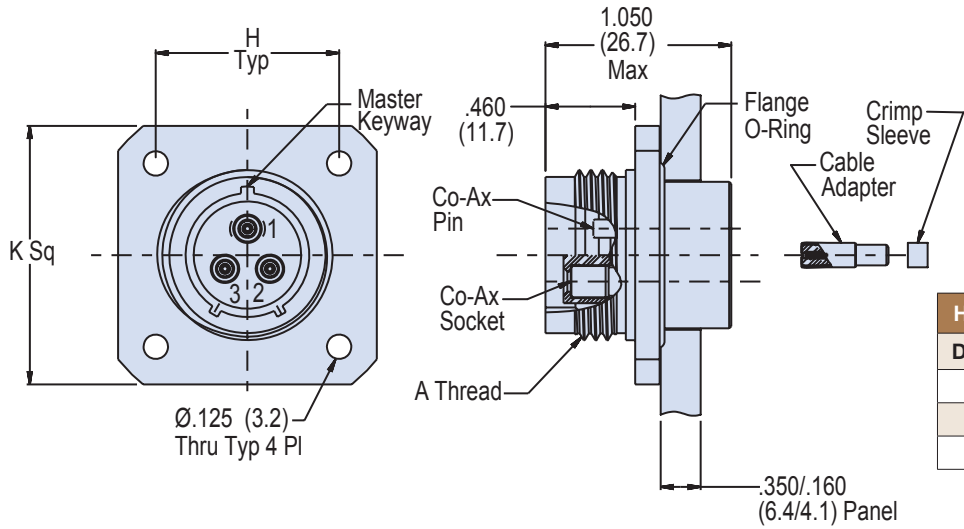

HERMETIC LEAK RATE MOD CODES	
Designator	Required Leak Rate
-585A	1 x 10 <sup>-10</sup> cc Helium per second
-585B	1 x 10 <sup>-9</sup> cc Helium per second
-585C	1 x 10 <sup>-8</sup> cc Helium per second

**Front Panel Square Flange Mount Submersible Hermetic**  
**802-040-02**

DIMENSIONS							
Shell Size	K Square		H Bsc.		A Mating Threads	Ø E	
	In.	mm.	In.	mm.		In.	mm.
5	.885	22.48	.500	12.70	.438-28 UNEF	.327	8.31
6	1.010	25.65	.625	15.88	.562-20 UN	.390	9.91
7	1.072	27.23	.688	17.48	.625-20 UN	.515	13.08
8	1.135	28.83	.750	19.05	.687-20 UN	.577	14.66
9	1.195	30.35	.812	20.62	.750-20 UNEF	.640	16.26
10	1.260	32.00	.875	22.23	.812-20 UNEF	.702	17.83
12	1.323	33.60	.938	23.83	.875-20 UNEF	.765	19.43
14	1.510	38.25	1.125	28.58	1.062-20 UN	.953	24.21
15	1.573	39.95	1.188	30.18	1.125-20 UN	1.015	25.78
21	1.750	44.45	1.375	34.93	1.4375-20 UN	1.312	33.32

**SERIES 802 RECEPTACLE KEY POSITIONS**

Key Position	Key Rotation	
	A°	B°
Normal (A)	150°	210°
B	75°	210°
C	95°	230°
D	140°	275°
E	75°	275°
F	95°	210°

**SERIES 802 SQ. FLANGE PANEL CUTOUT**

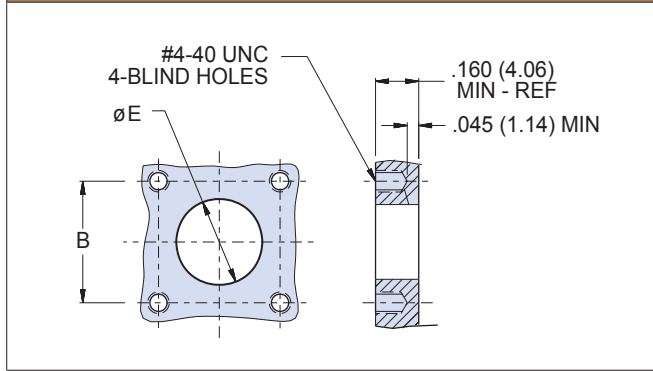

Dimensions in Inches (millimeters) are subject to change without notice.

802-040-03

Series 802 "Aqua Mouse" Submersible  
Coax Contacts • Sizes 12 and 16 Only  
Weld Mount Hermetic Receptacle



Series 80  
Mighty Mouse

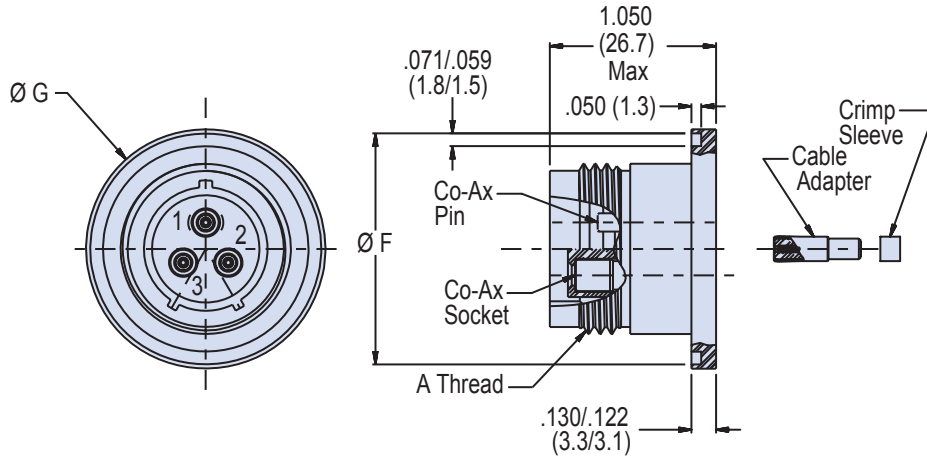

Weld Mount Submersible Hermetic  
802-040-03

DIMENSIONS					
Shell Size	Ø G		Ø F		A Mating Threads
	In. ±.006	mm. ±0.15	In. ±.006	mm. ±0.15	
5	.788	20.02	.745	18.92	.438-28 UNEF
6	.912	23.16	.869	22.07	.562-20 UN
7	.975	24.77	.933	23.70	.625-20 UN
8	1.038	26.37	.995	25.27	.687-20 UN
9	1.100	27.94	1.057	26.85	.750-20 UNEF
10	1.162	29.53	1.119	28.42	.812-20 UNEF
12	1.225	31.12	1.182	30.02	.875-20 UNEF
14	1.412	35.86	1.369	34.77	1.062-20 UN
15	1.475	37.47	1.432	36.37	1.125-20 UN
21	1.795	45.59	1.747	44.38	1.4375-20 UN

SERIES 802 RECEPTACLE KEY POSITIONS		
Key Position	Key Rotation	
	A°	B°
Normal (A)	150°	210°
B	75°	210°
C	95°	230°
D	140°	275°
E	75°	275°
F	95°	210°

Dimensions in Inches (millimeters) are subject to change without notice.



802-040-07

**Series 802 "Aqua Mouse" Submersible  
Coax Contacts • Sizes 12 and 16 Only  
Rear Panel Jam Nut Mount Hermetic Receptacle**

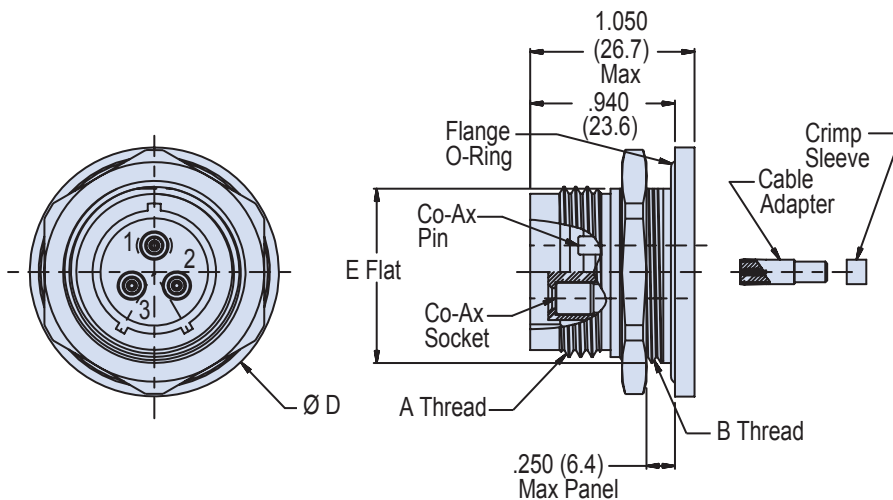

**Rear Panel Jam Nut Mount Submersible Hermetic  
802-040-07**

**DIMENSIONS**

Shell Size	D Max.		E Flat		A Mating Threads	B Threads
	In.	mm.	In. ± .003	mm. ± 0.08		
5	.885	22.48	.466	11.84	.438-28 UNEF	.500-32 UN-2A
6	1.010	25.65	.591	15.01	.562-20 UN	.625-20 UN-2A
7	1.072	27.23	.653	16.59	.625-20 UN	.687-28 UN-2A
8	1.135	28.83	.716	18.19	.687-20 UN	.750-28 UN-2A
9	1.195	30.35	.778	19.76	.750-20 UNEF	.812-28 UN-2A
10	1.260	32.00	.827	21.01	.812-20 UNEF	.875-28 UN-2A
12	1.322	33.58	.890	22.61	.875-20 UNEF	.938-28 UN-2A
14	1.510	38.25	1.077	27.36	1.062-20 UN	1.125-28 UN-2A
15	1.572	39.93	1.140	28.96	1.125-20 UN	1.188-28 UN-2A
21	1.940	49.28	1.464	37.19	1.4375-20 UN	1.500-28 UN-2A

**SERIES 802 RECEPTACLE KEY POSITIONS**

Key Position	Key Rotation	
	A°	B°
Normal (A)	150°	210°
B	75°	210°
C	95°	230°
D	140°	275°
E	75°	275°
F	95°	210°

Dimensions in Inches (millimeters) are subject to change without notice.

# 803-006

## Series 803 Mighty Mouse Hermetic Receptacles with ¼ Turn Bayonet Coupling How to Order Information



**Series 803 Hermetic  
Jam Nut Mount**

**Series 803 Hermetic Receptacles** feature 304L stainless steel shells, fused vitreous glass insulators and gold-plated Alloy 52 iron alloy contacts.

**1 X 10<sup>-7</sup> cc/second** maximum Helium leak rate when tested at 1 atmosphere vacuum.

**Two Shell Styles** are available: Jam Nut and Flange Mount.

**Solder Cup Contacts** accept up to #22 AWG stranded wire. Or, choose **Printed Circuit Board Contacts** for attachment to rigid boards or flexible circuits.

HERMETIC LEAK RATE MOD CODES	
Designator	Required Leak Rate
-585A	1 x 10 <sup>-10</sup> cc Helium per second
-585B	1 x 10 <sup>-9</sup> cc Helium per second
-585C	1 x 10 <sup>-8</sup> cc Helium per second

HOW TO ORDER					
Sample Part Number					
803-006	-07	Z1	9-19	P	N
Series	Shell Style	Shell Material / Finish	Shell Size/Insert	Contact Type	Shell Key Position
<b>803-006</b> Hermetic Receptacles with Printed Circuit Board Contacts or Solder Cup Contacts	<p><b>-02</b> Flange Mount</p> <p><b>-07</b> Jam Nut</p>	<p><b>Z1</b> Stainless Steel / Passivated</p> <p><b>ZL</b> Stainless Steel/ Nickel Plated</p> <p>*Titanium and Inconel® shell materials are available. Consult factory for ordering information.</p>	See Page C-4 for Contact Arrangements	<p><b>P</b> Pin, Solder Cup</p> <p><b>C</b> Pin, PC Tail</p> <p><b>S</b> Socket, Solder Cup</p> <p><b>D</b> Sockets, PC Tail</p>	<p><b>N</b> Normal</p> <p>Alternate Key Positions: <b>X</b> <b>Y</b> <b>Z</b></p>

Dimensions in Inches (millimeters) are subject to change without notice.



803-006-02 and 803-006-07  
Series 803 Mighty Mouse Hermetic Receptacles  
¼ Turn Bayonet Coupling Flange Mount and Jam Nut  
Connector Dimensions

C

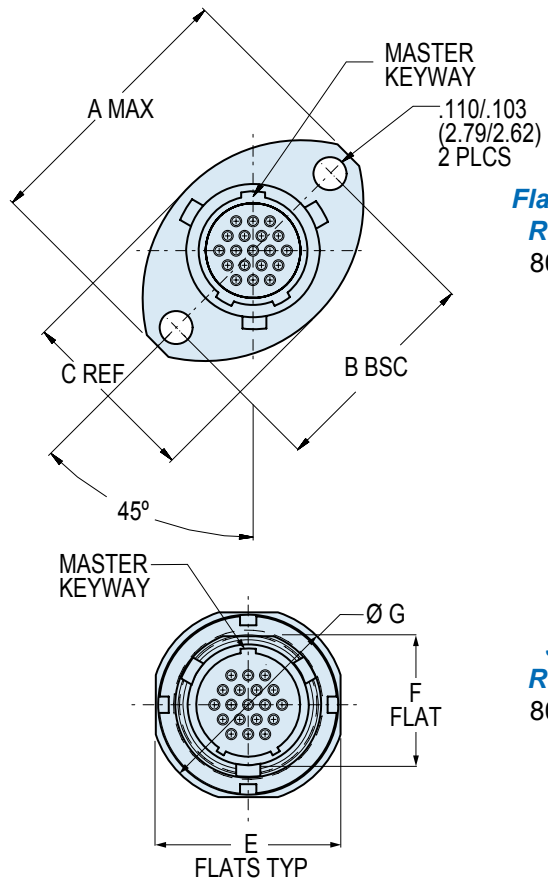

**Flange Mount Receptacle**  
803-006-02

**Jam Nut Receptacle**  
803-006-07

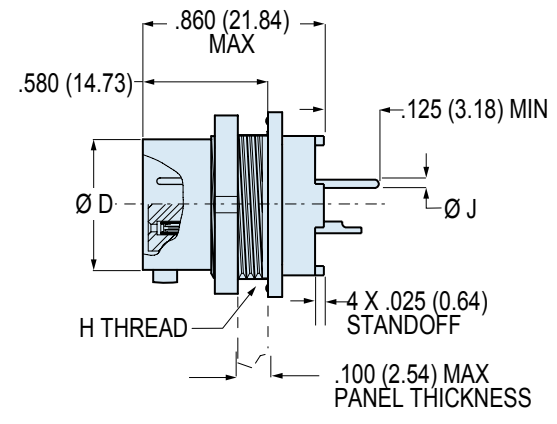
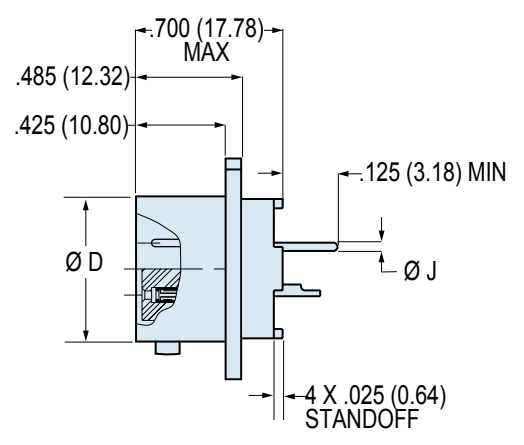

**DIMENSIONS**

Shell Size	A Max.		B Bsc.		C Ref.		Ø D		E Flats		F Flat		Ø G		H Thread	Ø J Tail Dia.
	In.	mm.	In.	mm.	In.	mm.	In.	mm.	In.	mm.	In.	mm.	In.	mm.		
5	.703	17.86	.513	13.03	.460	11.68	.300	7.62	.545	13.84	.350	8.89	.575	14.61	.3750-32 UNEF-2A	#23 .018/.022 (0.46/0.56)
6	.788	20.02	.598	15.19	.522	13.26	.362	9.19	.595	15.11	.410	10.42	.635	16.13	.4375-28 UNEF-2A	#20 .024/.028 (0.61/0.71)
7	.890	22.61	.708	17.98	.590	14.99	.436	11.07	.723	18.36	.536	13.61	.755	19.18	.5625-32 UN-2A	#16 .060/.064 (1.52/1.63)
8	1.154	29.31	.964	24.49	.668	16.97	.508	12.91	.790	20.07	.593	15.10	.755	19.18	.6250-32 UN-2A	#12 .092/.096 (2.34/2.44)
9	1.207	30.66	1.017	25.83	.721	18.31	.561	14.25	.790	20.07	.593	15.10	.830	21.08	.6250-28 UN-2A	
10	1.291	32.79	1.101	27.97	.795	20.19	.635	16.13	.925	23.51	.721	18.31	.890	22.61	.7500-28 UN-2A	
12	1.394	35.41	1.204	30.58	.874	22.20	.714	18.14	1.044	26.52	.845	21.46	1.078	27.38	.8750-28 UN-2A	
14	1.545	39.24	1.280	32.51	1.050	26.67	.865	21.97	1.230	31.24	1.022	25.96	1.264	32.11	1.0625-20 UN-2A	

Dimensions in Inches (millimeters) are subject to change without notice.



804-006

Series 804 Mighty Mouse Hermetic Receptacles  
Push-Pull Quick-Disconnect  
How to Order Information



Series 80  
Mighty Mouse



**Series 804 Hermetic Receptacles** feature 304L stainless steel shells, fused vitreous glass insulators and gold-plated Alloy 52 iron alloy contacts.

**1 X 10<sup>-7</sup> cc/second** maximum helium leak rate when tested at 1 atmosphere vacuum.

**Two Shell Styles** are available:  
**Style 00** for front panel mounting  
**Style 07** for rear panel mounting.

**"Push-Pull" Quick-Disconnect**  
Canted coil spring securely retains mating plug connector and provides low shell-to-shell resistance for excellent EMI shielding. O-ring inside receptacle shell provides water-tight seal when mated.

**Series 804 Hermetic  
Jam Nut Mount**

C

**HOW TO ORDER**

**Sample Part Number**

804-006	-07	Z1	9-19	P	A
Series	Shell Style	Shell Material / Finish	Shell Size/Insert	Contact Type	Shell Key Position
<b>804-006</b> Hermetic Receptacles with Printed Circuit Board Contacts or Solder Cup Contacts	<p><b>-00</b> Jam Nut, Front Panel</p>	<p><b>Z1</b> Stainless Steel / Passivated</p> <p><b>ZL</b> Stainless Steel/ Nickel Plated</p> <p>*Titanium and Inconel® shell materials are available. Consult factory for ordering information.</p>	See Page C-4 for Contact Arrangements	<p><b>P</b> Pin, Solder Cup</p> <p><b>C</b> Pin, PC Tail</p> <p><b>S</b> Socket, Solder Cup</p> <p><b>D</b> Socket, PC Tail</p>	<p><b>Omit</b> for Single Master Key</p> <p><b>A</b> Pos. A (Normal)</p> <p><b>B</b> Pos. B</p> <p><b>C</b> Pos. C</p> <p><b>D</b> Pos. D</p>
	<p><b>-07</b> Jam Nut, Rear Panel</p>				

Dimensions in Inches (millimeters) are subject to change without notice.

© 2013 Glenair, Inc.

U.S. CAGE Code 06324

Printed in U.S.A.



**804-006-00**  
**Series 804 Mighty Mouse Hermetic Receptacles**  
**Front Panel Jam Nut Mount Connector Dimensions**

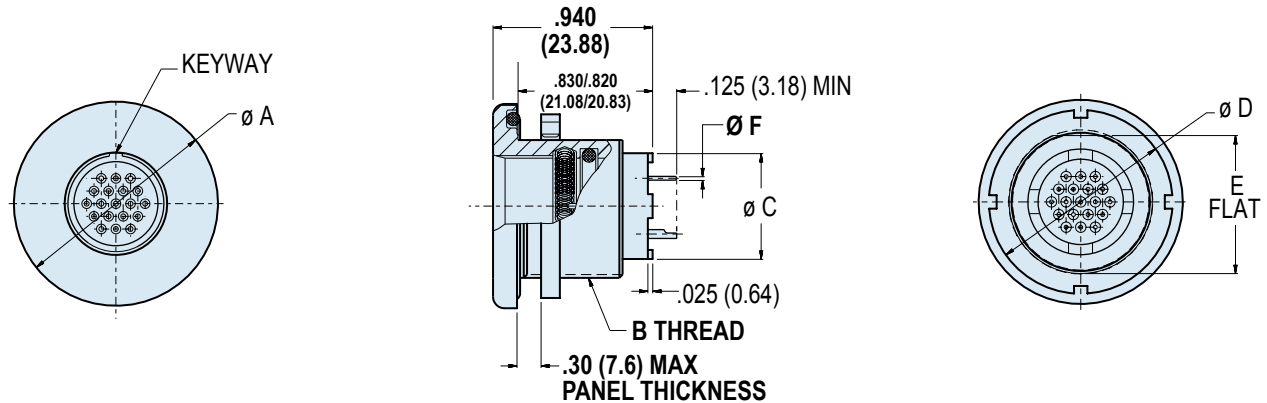

**Front Panel Jam Nut**  
804-006-00

DIMENSIONS										
Shell Size	Ø A		B Threads	Ø C		Ø D		E Flat		Ø F Tail Dia.
	In.	mm.		In.	mm.	In.	mm.	In.	mm.	
5	.830	21.08	.5000-32 UN-2A	.244	6.20	.625	15.87	.470	11.94	#23 .018/.022 (0.46/0.56) #20 .024/.028 (0.61/0.71) #16 .060/.064 (1.52/1.63) #12 .092/.096 (2.34/2.44)
6	.885	22.48	.5625-28 UN-2A	.336	8.53	.688	17.47	.530	13.46	
7	.995	25.27	.6875-32 UN-2A	.432	10.97	.812	20.62	.663	16.84	
8	.995	25.27	.6875-32 UN-2A	.493	12.52	.812	20.62	.663	16.84	
9	1.075	27.31	.7500-28 UN-2A	.551	14.00	.875	22.22	.720	18.29	
10	1.140	28.95	.8125-28 UN-2A	.620	15.75	.938	23.82	.788	20.02	
11	1.190	30.23	.8750-28 UN-2A	.662	16.81	1.000	25.40	.843	21.41	
12	1.340	34.04	1.0000-28 UN-2A	.703	17.86	1.125	28.57	.970	24.64	
14	1.390	35.31	1.0625-20 UN-2A	.863	21.92	1.162	41.15	1.020	25.91	

ALTERNATE KEY POSITIONS			
Pos.	A°	B°	
A	150°	210°	
B	75°	210°	
C	95°	230°	
D	140°	275°	
E	75°	275°	
F	95°	210°	

JAM NUT PANEL CUTOUT					
Shell Size	A Flat		Ø B		
	In. ± .002	mm. ± 0.05	In.	mm.	
5	.480	12.19	.510	12.95	
6	.540	13.72	.575	14.61	
7	.674	17.12	.698	17.73	
8	.674	17.12	.698	17.73	
9	.730	18.54	.760	19.30	
10	.799	20.29	.822	20.88	
11	.853	21.67	.885	22.48	
12	.980	24.89	1.010	25.65	
14	1.030	26.16	1.075	27.31	

Dimensions in Inches (millimeters) are subject to change without notice.

804-006-07

Series 804 Mighty Mouse Hermetic Receptacles  
Rear Panel Jam Nut Mount  
Dimensions



Series 80  
Mighty Mouse

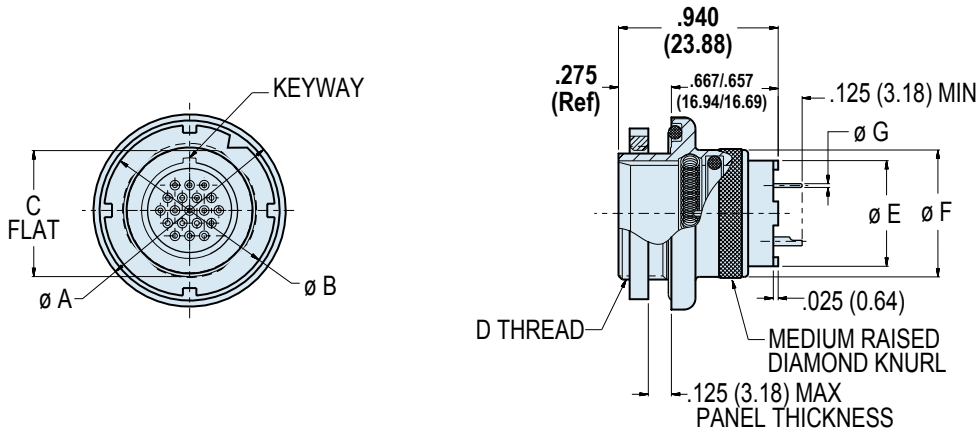

Rear Panel Jam Nut  
804-006-07

DIMENSIONS

Shell Size	Ø A		Ø B		C Flat		D Threads	Ø E		Ø F		Ø G Tail Dia.
	In.	mm.	In.	mm.	In.	mm.		In.	mm.	In.	mm.	
5	.790	20.07	.562	14.27	.415	10.54	.4375-32 UN-2A	.244	6.20	.450	11.43	#23 .018/.022 (0.46/0.56) #20 .024/.028 (0.61/0.71) #16 .060/.064 (1.52/1.63) #12 .092/.096 (2.34/2.44)
6	.830	21.08	.625	15.87	.467	14.40	.5000-32 UN-2A	.330	8.38	.520	13.21	
7	.910	23.11	.750	19.05	.594	15.09	.6250-28 UN-2A	.432	10.97	.580	14.73	
8	.955	24.26	.750	19.05	.594	15.09	.6250-28 UN-2A	.493	12.52	.603	15.32	
9	1.000	25.40	.812	20.62	.655	16.64	.6875-32 UN-2A	.551	14.00	.695	17.65	
10	1.085	27.48	.875	22.22	.721	18.31	.7500-28 UN-2A	.620	15.75	.735	18.67	
11	1.135	28.83	.938	23.82	.788	20.01	.8125-28 UN-2A	.662	16.81	.810	20.57	
12	1.180	29.97	1.000	25.40	.843	21.41	.8750-28 UN-2A	.703	17.86	.880	22.35	
14	1.325	33.66	1.125	28.57	.968	24.59	1.0000-28 UN-2A	.863	21.92	1.010	25.65	

ALTERNATE KEY POSITIONS

Pos.	A°	B°
A	150°	210°
B	75°	210°
C	95°	230°
D	140°	275°
E	75°	275°
F	95°	210°

JAM NUT PANEL CUTOUT

Shell Size	A Flat		Ø B	
	In. ±.002	mm. ±0.05	In.	mm.
5	.425	10.80	.448	11.38
6	.477	12.12	.510	12.95
7	.604	15.34	.635	16.13
8	.604	15.34	.635	16.13
9	.665	16.89	.695	17.65
10	.731	18.57	.760	19.30
12	.853	21.67	.885	22.48
14	.978	24.84	1.010	25.65

Dimensions in Inches (millimeters) are subject to change without notice.



**805-006**  
**Series 805 Mighty Mouse Hermetic Receptacles**  
**Triple-Start Threaded Ordering Information**



**Series 805 Hermetic Jam Nut Connector**



**Series 805 Hermetic Receptacles** feature 304L stainless steel shells, fused vitreous glass insulators and Alloy 52 iron alloy contacts. Triple-start ACME thread provides fast mating and cross-threading protection. Mating plug connectors feature EMI springs and ratcheting anti-decoupling mechanism for resistance to vibration. 1000 PSI open face pressure. Fluorosilicone seals for water ingress protection. Contacts are gold-plated 50 microinches minimum.

**1 X 10<sup>-7</sup> cc/second** maximum helium leak rate.

**Four Shell Styles:** jam nut, square flange, solder mount or weld mount.

**Solder Cup Contacts** for #22 AWG wire, or **PC Tail Contacts** for attachment to flexible or rigid circuits.

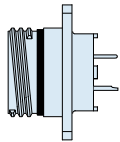
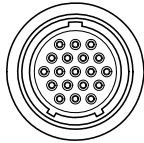
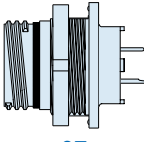
**HOW TO ORDER SERIES 800 HERMETIC RECEPTACLES**

Sample Part Number					
805-006	-07	Z1	12-26	C	A
Series	Shell Style	Shell Material / Finish	Shell Size- Insert Arrangement	Contact Type	Shell Key Position
<p><b>805-006</b> Hermetic Receptacle</p>	 <p style="text-align: center;"><b>-02</b> Square Flange</p>  <p style="text-align: center;"><b>-03</b> Solder Mount</p>  <p style="text-align: center;"><b>-07</b> Jam Nut</p>  <p style="text-align: center;"><b>-13</b> Weld Mount</p>	<p style="text-align: center;"><b>Z1</b> Stainless Steel / Passivated</p> <p style="text-align: center;"><b>ZL</b> Stainless Steel / Nickel Plated</p> <p style="text-align: center;">*Titanium and Inconel® shell materials are available. Consult factory for ordering information.</p>	<p style="text-align: center;">See Page C-4 for Contact Arrangements</p>	<p style="text-align: center;"><b>P</b> Pin, Solder Cup</p> <p style="text-align: center;"><b>C</b> Pin, PC Tail</p> <p style="text-align: center;"><b>S</b> Socket, Solder Cup</p> <p style="text-align: center;"><b>D</b> Socket, PC Tail</p>	<p style="text-align: center;"><b>A</b> Position A (Normal)</p> <p style="text-align: center;"><b>B</b> Position B</p> <p style="text-align: center;"><b>C</b> Position C</p> <p style="text-align: center;"><b>D</b> Position D</p> <p style="text-align: center;"><b>E</b> Position E</p> <p style="text-align: center;"><b>F</b> Position F</p>

Dimensions in Inches (millimeters) are subject to change without notice.

**805-006-02**  
**Series 805 Mighty Mouse Triple-Start**  
**Flange Mount Hermetic Receptacles**



Series 80  
Mighty Mouse

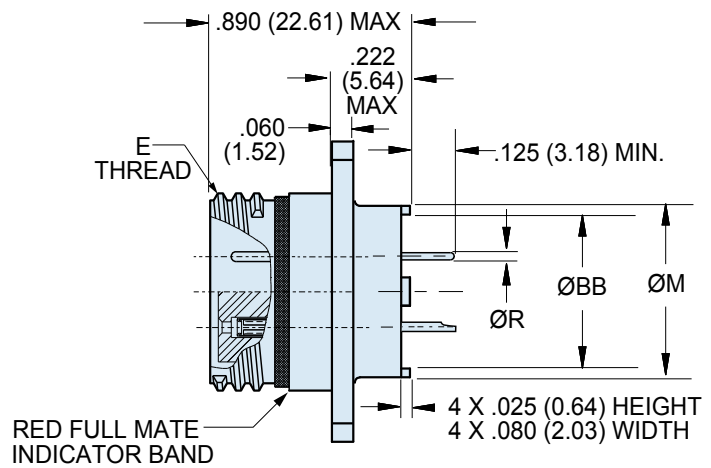
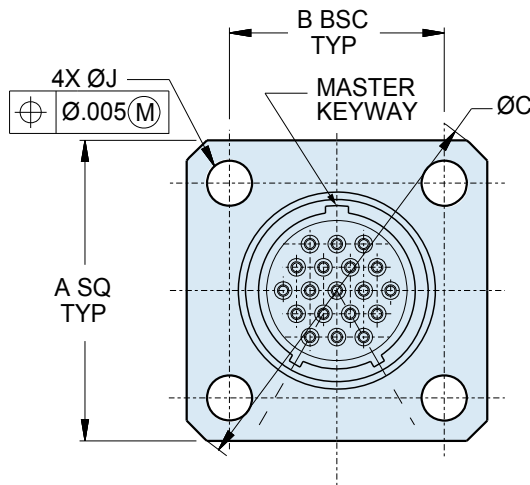

C

**DIMENSIONS**

Shell Size	A SQ		B BSC		BB		Ø C		Ø J Holes	K Threads	Ø M		Ø R Tail Dia.
	In.	mm.	In.	mm.	In.	mm.	In.	mm.			In.	mm.	
8	.850	21.59	.660	16.76	.236	5.99	1.150	29.21	.096 (2.44) .091 (2.31)	.5000-.1P-.3L-TS-2A	.330	8.38	#23 .018/.022 (0.46/0.56)
9	.913	23.19	.723	18.36	.322	8.18	1.230	31.24		.5625-.1P-.3L-TS-2A	.432	10.97	
10	.975	24.77	.785	19.94	.386	9.80	1.330	33.78		.6250-.1P-.3L-TS-2A	.493	12.52	#20 .024/.028 (0.61/0.71)
11	1.039	26.39	.848	21.54	.442	11.23	1.410	35.81		.6875-.1P-.3L-TS-2A	.553	14.05	
12	1.099	27.91	.909	23.09	.513	13.03	1.500	38.10		.7500-.1P-.3L-TS-2A	.620	15.75	#16 .060/.064 (1.52/1.63)
13	1.163	29.54	.973	24.71	.554	14.07	1.590	40.39		.8125-.1P-.3L-TS-2A	.661	16.79	
15	1.288	32.74	1.058	26.87	.594	15.09	1.750	44.45		.9375-.1P-.3L-TS-2A	.703	17.86	#12 .092/.096 (2.34/2.44)
18	1.475	37.47	1.255	31.88	.755	19.18	2.000	50.80		1.1250-.1P-.3L-TS-2A	.863	21.92	
19	1.537	71.06	1.327	33.71	.805	20.45	2.094	53.19		.126 (3.30)	1.1875-.1P-.3L-TS-2A	.912	23.16
21	1.663	42.24	1.452	36.88	.910	23.11	2.270	57.66		(3.20)	1.3125-.1P-.3L-TS-2A	1.017	25.83
23	1.787	44.68	1.576	40.03	1.055	26.80	2.440	61.98		1.4375-.1P-.3L-TS-2A	1.162	29.51	

**PERFORMANCE SPECIFICATIONS**

DWV (VAC Sea Level)	#23 500 V., #20HD 750 V., #12 AND #16 1800 V.
Insulation Resistance	5000 Megohms Minimum
Operating Temperature	-55° C. to +150° C.
Immersion, Mated	MIL-STD-810 Method 512. One Meter for One Hour.
Hermeticity	1 x 10 <sup>-7</sup> cc/sec Helium Leak Rate @ 1 Atmosphere Diff.

**MATERIALS AND FINISHES**

Shell	304L Stainless Steel
Insulator	Fused Vitreous Glass
Seals	Fluorosilicone Rubber, Blue
Contacts	Iron Alloy (Alloy 52)

**SERIES 805 KEY POSITIONS**

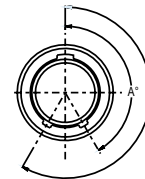

Key Position	Key Rotation	
	A°	B°
Normal (A)	150°	210°
B	75°	210°
C	95°	230°
D	140°	275°
E	75°	275°
F	95°	210°

Dimensions in Inches (millimeters) are subject to change without notice.

© 2013 Glenair, Inc.

U.S. CAGE Code 06324

Printed in U.S.A.

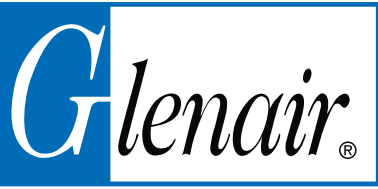

805-006-03

Series 805 Mighty Mouse Triple-Start  
Solder Mount Hermetic Receptacles

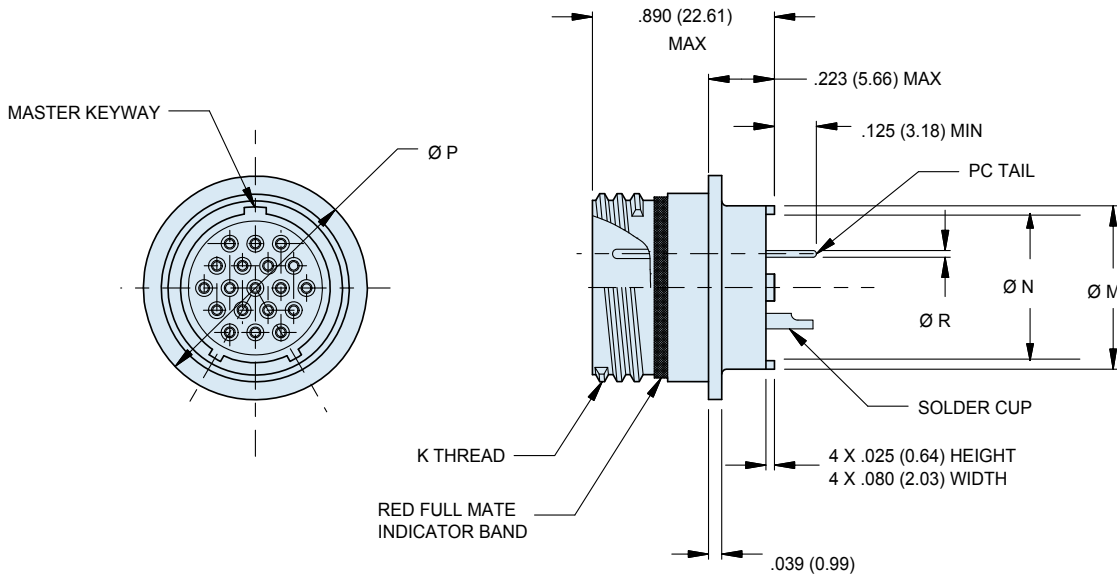

DIMENSIONS

Shell Size	Ø P		B Threads	M Ø		N Ø		Ø R Tail Dia.
	In.	mm.		In.	mm.	In.	mm.	
8	.625	15.88	.5000-.1P-.3L-TS-2A	.330	8.38	.236	5.99	#23
9	.688	17.48	.5625-.1P-.3L-TS-2A	.432	10.97	.322	8.18	.018/.022
10	.750	19.75	.6250-.1P-.3L-TS-2A	.493	12.52	.386	9.80	(0.46/0.56)
11	.812	20.62	.6875-.1P-.3L-TS-2A	.553	14.05	.442	11.23	#20
12	.875	22.23	.7500-.1P-.3L-TS-2A	.620	15.75	.513	13.03	.024/.028
13	.938	23.83	.7500-.1P-.3L-TS-2A	.661	16.79	.554	14.07	(0.61/0.71)
15	1.062	26.97	.9375-.1P-.3L-TS-2A	.703	17.86	.594	15.09	#16
18	1.250	31.75	1.1250-.1P-.3L-TS-2A	.863	21.92	.755	19.18	.060/.064
19	1.312	33.32	1.1875-.1P-.3L-TS-2A	.912	23.16	.805	20.45	(1.52/1.63)
21	1.438	36.53	1.3725-.1P-.3L-TS-2A	1.017	25.83	.910	23.11	#12
23	1.562	39.67	1.4375-.1P-.3L-TS-2A	1.162	29.51	1.055	26.80	.092/.096
								(2.34/2.44)

SERIES 805 KEY POSITIONS

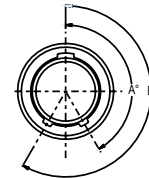

Key Position	Key Rotation	
	A°	B°
Normal (A)	150°	210°
B	75°	210°
C	95°	230°
D	140°	275°
E	75°	275°
F	95°	210°

Dimensions in Inches (millimeters) are subject to change without notice.

805-006-07

Series 805 Mighty Mouse Triple-Start  
Jam Nut Mount Hermetic Receptacles



Series 80  
Mighty Mouse

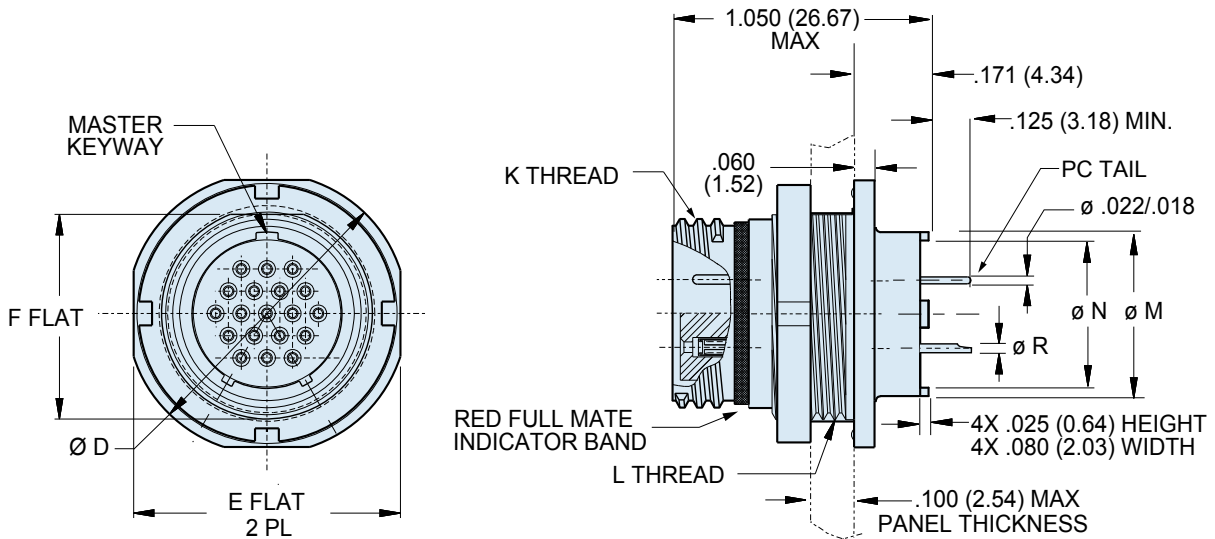

C

DIMENSIONS													
Shell Size	Ø D		E Flat		F Flat		Ø M		Ø N		K Thread	L Thread	Ø R Tail Dia.
	In.	mm.	In.	mm.	In.	mm.	In.	mm.	In.	mm.			
8	.760	19.30	.730	18.54	.535	13.59	.330	8.38	.236	5.99	.5000-.1P-.3L-TS-2A	.5625-28 UNEF-2A	#23 .018/.022 (0.46/0.56)
9	.880	22.35	.850	21.59	.661	16.79	.432	10.97	.322	8.18	.5625-.1P-.3L-TS-2A	.6875-28 UN-2A	#20 .024/.028 (0.61/0.71)
10	.880	22.35	.850	21.59	.661	16.79	.493	12.52	.386	9.80	.6250-.1P-.3L-TS-2A	.6875-28 UN-2A	#20 .024/.028 (0.61/0.71)
11	.955	24.26	.925	23.50	.721	18.31	.553	14.05	.442	11.23	.6875-.1P-.3L-TS-2A	.7500-28 UN-2A	#16 .060/.064 (1.52/1.63)
12	1.060	26.92	1.035	26.29	.784	19.91	.620	15.75	.513	13.03	.7500-.1P-.3L-TS-2A	.8125-28 UN-2A	#12 .092/.096 (2.34/2.44)
13	1.120	28.45	1.090	27.69	.843	21.41	.661	16.79	.554	14.07	.8125-.1P-.3L-TS-2A	.8750-28 UN-2A	
15	1.203	30.56	1.173	29.79	.970	24.64	.703	17.86	.594	15.09	.9375-.1P-.3L-TS-2A	1.0000-28 UN-2A	
18	1.389	35.28	1.359	34.52	1.147	29.13	.863	21.92	.755	19.18	1.1250-.1P-.3L-TS-2A	1.1875-28 UN-2A	
19	1.450	36.83	1.420	36.07	1.221	31.01	.912	23.16	.805	20.45	1.1875-.1P-.3L-TS-2A	1.2500-28 UN-2A	
21	1.580	40.13	1.550	39.37	1.350	34.29	1.017	25.83	.910	23.11	1.3125-.1P-.3L-TS-2A	1.3750-28 UN-2A	
23	1.705	43.31	1.675	42.55	1.470	37.34	1.162	29.51	1.055	26.80	1.4375-.1P-.3L-TS-2A	1.5000-25 UN-2A	

PANEL CUTOUT FOR JAM NUT RECEPTACLE				
Shell Size	G Flat		Ø H	
	In.	mm.	In.	mm.
8	.547 .543	13.89 13.79	.575 .571	14.61 14.50
9	.673 .669	17.09 16.99	.700 .696	17.78 17.68
10	.673 .669	17.09 16.99	.700 .696	17.78 17.68
11	.733 .729	18.62 18.52	.762 .758	19.35 19.25
12	.796 .792	20.22 20.12	.825 .821	20.96 20.85
13	.853 .849	21.67 21.56	.887 .883	22.53 22.43
15	.982 .978	24.94 24.84	1.012 1.008	25.70 25.60
18	1.159 1.155	29.44 29.34	1.200 1.196	30.48 30.38
19	1.233 1.229	31.32 31.22	1.262 1.258	32.05 31.95
21	1.360 1.356	34.54 34.44	1.387 1.383	35.23 35.13
23	1.482 1.478	37.64 37.54	1.512 1.508	38.40 38.30

SERIES 805 KEY POSITIONS		
Key Position	Key Rotation	
	A°	B°
Normal (A)	150°	210°
B	75°	210°
C	95°	230°
D	140°	275°
E	75°	275°
F	95°	210°

Dimensions in Inches (millimeters) are subject to change without notice.





805-006-13

Series 805 Mighty Mouse Triple-Start  
Front Panel Weld Mount Hermetic Receptacles

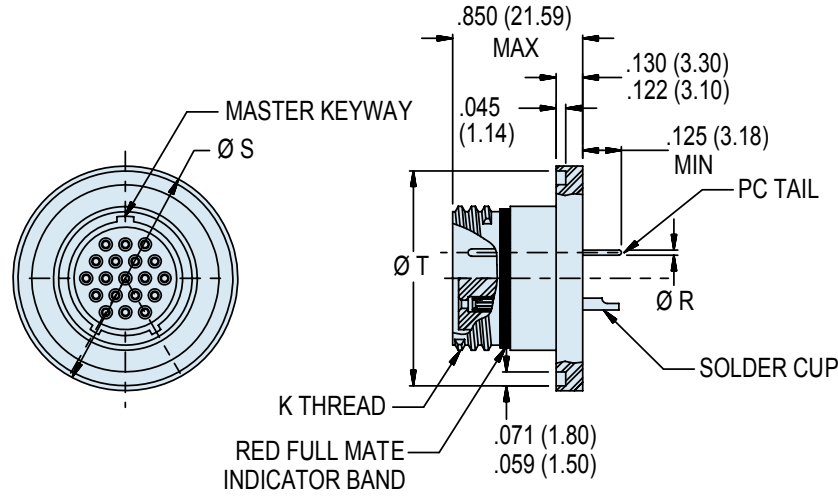

C

DIMENSIONS						
Shell Size	K Thread	Ø S ± .002		Ø T ± .006		Ø R Tail Dia.
		In.	mm.	In.	mm.	
8	.5000-1p-3L-TS	.788	20.02	.745	18.92	#23 .018/.022 (0.46/0.56)
9	.5625-1p-3L-TS	.912	23.16	.869	22.07	
10	.6250-1p-3L-TS	.975	24.77	.933	23.70	
11	.6875-1p-3L-TS	1.038	26.37	.995	25.27	#20 .024/.028 (0.61/0.71)
12	.7500-1p-3L-TS	1.100	27.94	1.057	26.85	
13	.8125-1p-3L-TS	1.162	29.51	1.119	28.42	#16 .060/.064 (1.52/1.63)
15	.9375-1p-3L-TS	1.288	32.72	1.245	31.63	
18	1.1250-1p-3L-TS	1.475	37.47	1.430	36.32	#12 .092/.096 (2.34/2.44)
19	1.1875-1p-3L-TS	1.540	39.12	1.495	37.97	
21	1.3125-1p-3L-TS	1.665	42.29	1.620	41.15	
23	1.4375-1p-3L-TS	1.795	45.59	1.750	44.45	

SERIES 805 KEY POSITIONS

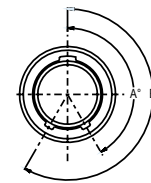

Key Position	Key Rotation	
	A°	B°
Normal (A)	150°	210°
B	75°	210°
C	95°	230°
D	140°	275°
E	75°	275°
F	95°	210°

PANEL CUTOUT FOR WELD MOUNT RECEPTACLE

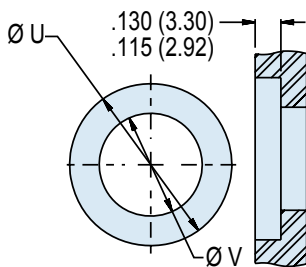

Shell Size	Ø U ± .003		Ø V Min	
	In.	mm.	In.	mm.
8	.794	20.16	.350	8.89
9	.918	23.32	.455	11.56
10	.981	24.92	.520	13.21
11	1.044	26.52	.575	14.61
12	1.106	28.09	.650	16.51
13	1.168	29.67	.685	17.40
15	1.294	32.87	.730	18.54
18	1.481	37.62	.890	22.61
19	1.546	39.27	.940	23.88
21	1.671	42.44	1.040	26.42
23	1.801	45.75	1.190	30.23

Dimensions in Inches (millimeters) are subject to change without notice.

MIL-DTL-26482  
TYPE

# BAYONET-LOCK

*Hermetic Connectors  
Fast and Reliable Mating*



**G**lenair MIL-DTL-26482 Series I and II Bayonet-Lock Connectors are ideally suited for vacuum chambers and other military and commercial applications that utilize this general purpose medium density cylindrical connector and require helium leak test rates of less than  $1 \times 10^{-7}$  cc/second. The bayonet mechanism provides fast and easy coupling, especially when the connector is situated in an awkward or hard to reach location. A wide range of available mounting styles—including both narrow and wide flange mounts—provide complete flexibility in interconnect system design. PCB and solder cup contacts allow easy integration and termination to I/O cabling and electronic sub-systems. Glenair MIL-DTL-26482 Type hermetics are interchangeable and intermateable with the wide range of industry-standard bayonet connectors designed around MIL-DTL-26482 and/or qualified to VG 95328, including ITT Cannon KPT.

GLASS-SEALED  
**Hermetic**  
CONNECTORS

**G**lenair®

Glenair, Inc.  
1211 Air Way  
Glendale, CA  
91201-2497  
818-247-6000  
sales@glenair.com  
www.glenair.com

# MIL-DTL-26482 Type Quick Release Bayonet Hermetic Connectors



## A Comprehensive Line of MIL-DTL-26482 Series I and II Type Bayonet Glass Sealed Hermetic Connectors

**MIL-DTL-26482 Series I and II Bayonet Lock Connectors** are general purpose medium density connectors, with a variety of mounting styles including bulkhead feed-thrus, jam-nut, flange mount and solder cup receptacles. All feature quick release

bayonet coupling. 9 shell sizes with up to 61 AWG contacts in size #20, #16, and #12 and #8 are offered. Material and finish options include titanium and Inconel®, and space grade screening is available.

Quick Selection Guide		
Part Number	Description	Page
	MIL-DTL-26482 Type Insert Arrangements	D-2
	MIL-DTL-26482 Type Alternate Key Positions	D-3
	Glenair Hermetic Connector Products Special Leak Rate Mod Codes	D-4
	Glenair Hermetic Connector Products Space Grade Mod Codes	D-5
<b>230-014</b>	Bayonet Coupling Solder Mount Receptacle MS3113 Type	D-6
<b>230-015</b>	Bayonet Coupling Jam Nut Receptacle MS3114 Type	D-8
<b>947-303</b>	Narrow Flange Mount Bulkhead Feed-Thru MS3440 Type	D-10
<b>230-035</b>	Bayonet Coupling Narrow Flange Mount Receptacle MS3112 Type	D-12
<b>230-016</b>	Bayonet Coupling Narrow Flange Mount Receptacle MS3440 Type	D-14
<b>230-017</b>	Bayonet Coupling Wide Flange Mount Receptacle MS3442 Type	D-16
<b>230-018</b>	Bayonet Coupling Solder Flange Mount Receptacle MS3443 Type	D-18
<b>230-019</b>	Quick Release Bayonet Receptacle, Single Hole Jam Nut MS3449 Type	D-20
<b>230-020</b>	Bayonet Coupling Solder Mount Receptacle with Solderless Contacts MS3473 Type	D-22
<b>230-021</b>	Bayonet Coupling Box Mount Receptacle with Solderless Contacts MS3477 Type	D-24
<b>230-022</b>	Bayonet Coupling Jam Nut Mount Receptacle with Solderless Contacts MS3479 Type	D-26
<b>237-034</b>	Bayonet Coupling Jam Nut Receptacle MS3449 Type	D-28
<b>230-051</b>	Special Narrow Square Flange Mount Hermetic Receptacle MS3440 Type	D-30
<b>230-133</b>	Square Flange Mount Hermetic Receptacle MS3112 Type	D-32
<b>237-240</b>	MIL-DTL-26482 Series I Connector, Special Square Flange Mount, Bayonet Coupling	D-34
<b>257-135</b>	Bayonet Coupling Jam Nut Mount Pin/Pin Bulkhead Feed-Thru Receptacle	D-36
<b>947-292</b>	Bayonet Coupling Jam Nut Mount Bulkhead Feed-Thru Receptacle	D-38

Dimensions in Inches (millimeters) are subject to change without notice.



# MIL-DTL-26482 Type Insert Arrangements per MIL-DTL-1669

D

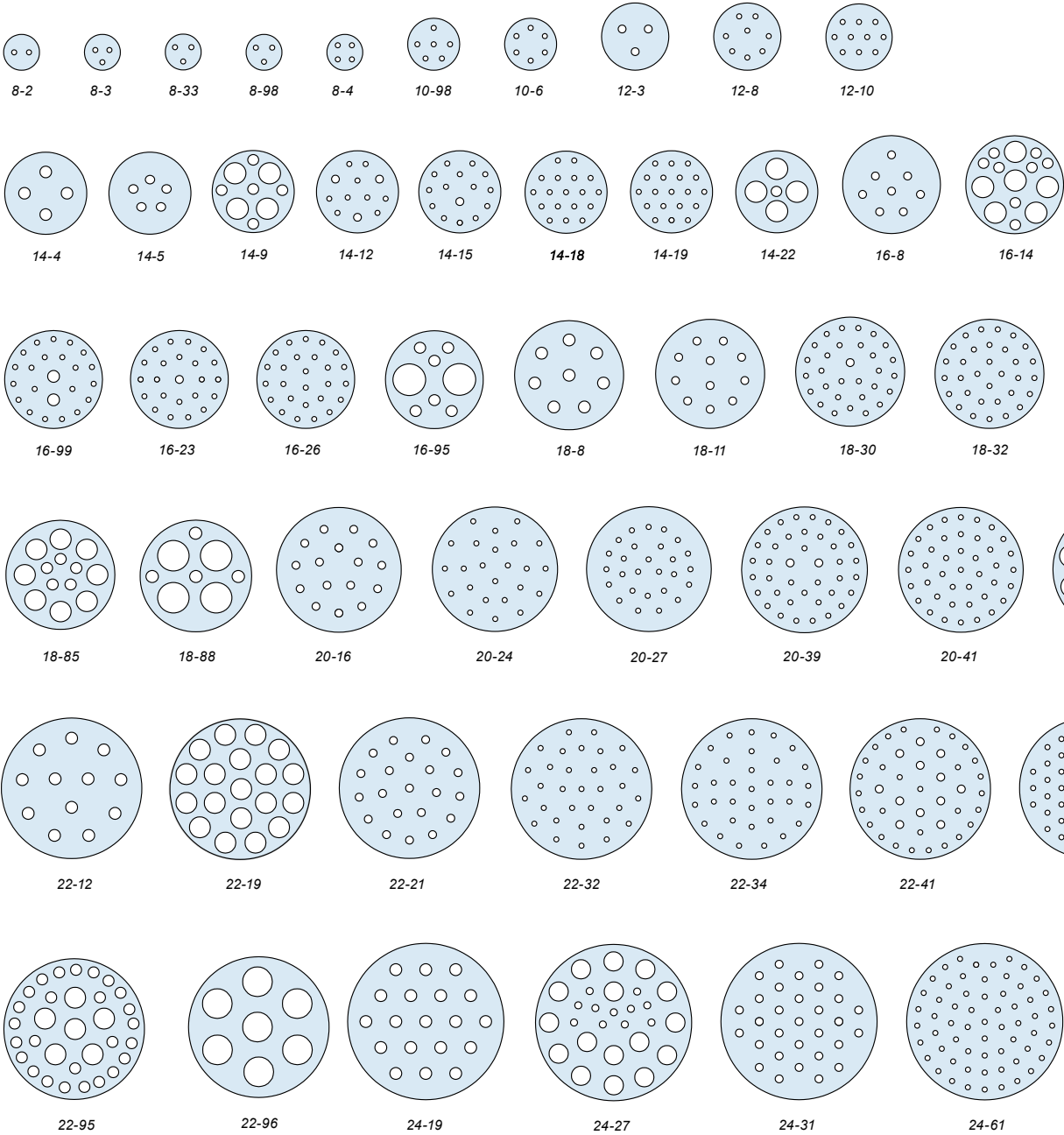

# MIL-DTL-26482 Type Key/Keyway Positions



MIL-DTL-26482  
Type

D

Insert Arrangements						
Shell Size Designator	Insert Arrangement Dash Number	Contact Size and Quantity				Service Rating
		20	16	12	8	
8	8-2	2				I
	8-3	3				I
	8-4	4				I
	8-33	3				I
	8-98	3				I
10	10-6	6				I
	10-98	6				I
12	12-3		3			II
	12-8	8				I
	12-10	10				I
14	14-4			4		I
	14-5		5			II
	14-9	5		4		I
	14-12	8	4			I
	14-15	14	1			I
	14-18	18				I
	14-19	19				I
	14-22	1		4		I
16	16-8		8			II
	16-14	8		6		I
	16-23	22	1			I
	16-26	26				I
	16-95	6			2 <sup>1</sup>	I
	16-99	21	2			I
18	18-8			8		I
	18-11		11			II
	18-30	29	1			I
	18-32	32				I
	18-85	5		8		I
	18-88	88			4 <sup>1</sup>	I
20	20-16		16			II
	20-24	24				I
	20-27	27				I
	20-39	37	2			I
	20-41	41				I
	20-90	3		12		I
22	22-12			12		I
	22-19			19		I
	22-21		21			II
	22-32	32				I
	22-34	34				I
	22-41	27	14			I
	22-55	55				I
	22-95	26		6		I
22-96				7 <sup>1</sup>	I	
24	24-19			19		II
	24-27	11		16		I
	24-31		31			I
	24-61	61				I

Note 1: Shielded, not applicable to Series II or hermetic connectors.

© 2013 Glenair, Inc.

U.S. CAGE Code 06324

Printed in U.S.A.

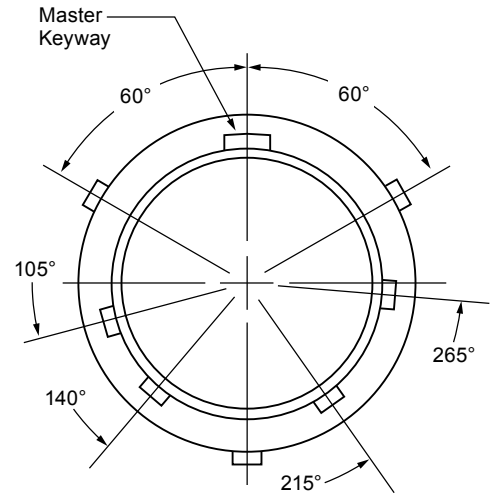

Receptacle

Inserts rotate from centerline of master key/keyway clockwise for pin inserts (counter-clockwise for socket inserts) as specified in MIL-STD-1669. Refer to MIL-STD-1669 or consult factory for alternate insert information.

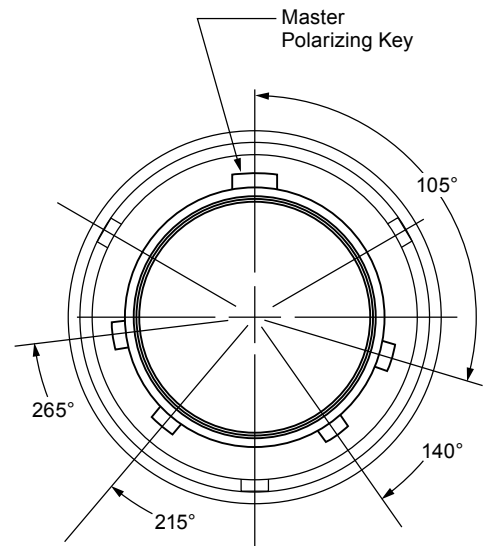

Plug



## Glenair Hermetic Connector Products Special Leak Rate Mod Codes

D

### Leak Rate Designator

**B** – (See Table Below)

**– 585 B**

### Mod Code

**585** – Increased Hermeticity Mod Code

#### What is the –585 Mod Code?

Glenair offers an array of hermetic connectors with more stringent leak rate requirements. By adding “–585” and the designator letter “A”, “B” or “C”—depending on the hermeticity desired—to the end of a standard part number, connectors will be built to exceed the standard  $1 \times 10^{-7}$  cc Helium per second leak rate specified on most Glenair hermetics.

#### HERMETIC LEAK RATE MOD CODES

Designator	Required Leak Rate
<b>A</b>	$1 \times 10^{-10}$ cc's Helium per second
<b>B</b>	$1 \times 10^{-9}$ cc's Helium per second
<b>C</b>	$1 \times 10^{-8}$ cc's Helium per second

#### Catalog Notes

For all parts in this catalog:

- All parts will be identified with manufacturer's name and part number, space permitting.
- Glenair 600 series backshell assembly tools are recommended for assembly and installation.
- Dimensions are subject to change without notice. Metric dimensions appear in parentheses in diagrams and tables, based on 1 inch = 25.4 mm, for reference only. Unless otherwise specified, the following other dimensional tolerances apply:

.xx = ± .03 (0.8)      Lengths = ± .060 (1.52)  
.xxx = ± .015 (0.4)      Angles = ± 5°

Customers are advised to consult the factory for the latest specifications, particularly to confirm critical dimensions such as connector lengths, threads, and so on. When errors or mistakes are brought to our attention, corrected content is posted immediately to [www.glenair.com](http://www.glenair.com).



# Glenair Hermetic Connector Products Space Grade Mod Codes



MIL-DTL-26482  
Type

D

## What is outgassing?

Plastic and rubber materials give off gaseous molecules. For example, the smell inside a new car is caused by polymer outgassing. Heat and vacuum increase the rate of diffusion. In a spacecraft the gases coming off polymers can contaminate optical surfaces and instruments. The result is degraded performance.

## How is outgassing measured?

The space industry has adopted a standardized test procedure, **ASTM E 595**, to evaluate out-gassing properties of polymers. Small samples of material are heated to 125° C. at a vacuum of  $5 \times 10^{-5}$  torr for 24 hours. Then the sample is weighed to calculate the **Total Mass Loss** (TML). The TML cannot exceed 1.00% of the total initial mass. During the test, outgassed matter condenses on a cooled collector plate. The quantity of outgassed matter is calculated to determine the **Collected Volatile Condensable Material** (CVCM). The CVCM cannot exceed 0.10% of the original specimen mass.

## What is NASA screening?

NASA specification EEE-INST-002 provides instructions on selecting, screening and qualifying parts for use on NASA GSFC space flight projects.

## What screening level is required?

NASA defines three levels of screening: level 1 for highest reliability, level 2 for high reliability, and level 3 for standard reliability. Level 3 equates to standard lot acceptance inspection. Levels 1 and 2 call for additional testing.

## HOW TO ORDER SPACE GRADE CONNECTORS

### Step 1: Find a Standard Part Number

Electroless nickel plated shells are preferred for space flight. Cadmium plating is prohibited.

### Step 2: Select a NASA Screening Level

The term "Screening Level" refers to the final inspection procedure.

**Level 1** for mission-critical highest reliability

**Level 2** for high reliability

**Level 3** for standard reliability

### Step 3: Choose Outgassing Processing

A detailed explanation of outgassing is on the following pages. The fluorosilicone rubber seals commonly used on aerospace-grade connectors such as MIL-DTL-38999 and Series 79 connectors, along with certain bonding agents and inks, do not meet NASA outgassing requirements unless the connector is specially processed. Glenair outgassing tests have shown oven baking or thermal vacuum outgassing processing are sufficient to reduce outgassing levels to NASA standards. Oven baking is more economical than thermal vacuum outgassing.

### Step 4: Select the Mod 429 Code that Matches the Desired Level of Screening and Outgassing

Use the following table to choose the right modification code. Add the mod code to the connector part number. Example: 790-024PC-13ML-**429C**

## NASA SCREENING LEVELS AND MODIFICATION CODES

NASA Screening Level	Special Screening Only	Special Screening Plus Outgassing Processing	
		8 Hour Oven Bake 400° F.	Thermal Vacuum Outgassing 24 hrs. 125° C.
Level 1 Highest Reliability	Mod 429B	Mod 429J	Mod 429C
Level 2 High Reliability	Mod 429	Mod 429K	Mod 429A
Level 3 Standard Reliability	(Use standard part number)	Mod 186	Mod 186M



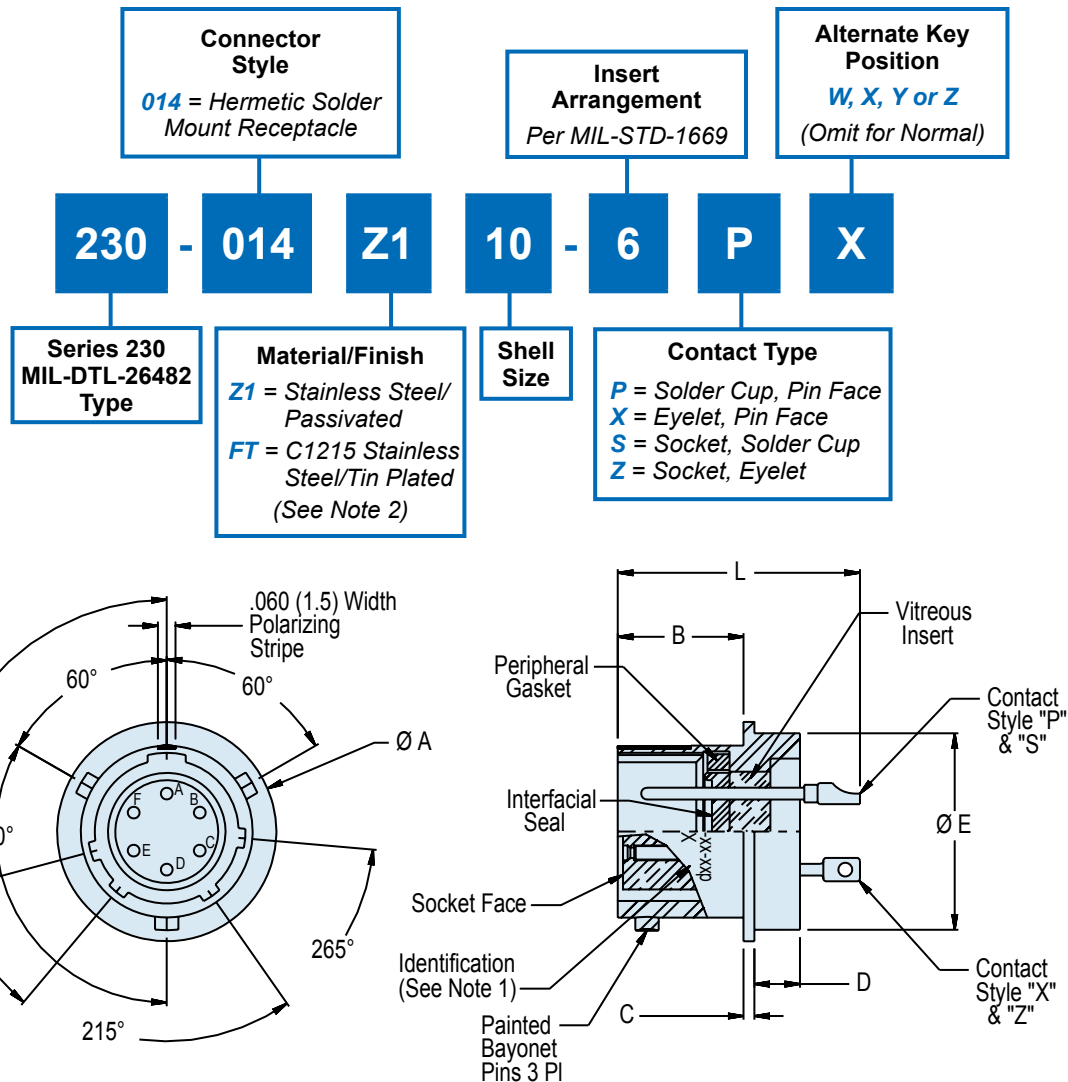

## APPLICATION NOTES

- To be identified with manufacturer's name, part number and date code, space permitting.
- Material/Finish:  
Shell: Z1 - 304L stainless steel/passivate.  
FT - C1215 stainless steel/tin plated.  
Titanium and Inconel® available. Consult factory.  
Contacts - 52 Nickel alloy/gold plate.  
Sockets - Copper alloy, gold plated.  
Bayonets - Stainless steel/passivate.  
Seals - Silicone elastomer/N.A.  
Insulation - Glass/N.A.; Socket: Rigid Dielectric/N.A.
- Contact current rating - #20-5 Amps, #16-10 Amps, #12-17 Amps, #8-46 Amps.
- Consult factory and/or MIL-STD-1669 for arrangement and insert position options.
- Glenair 230-014 will mate with any QPL MIL-DTL-26482 Series I bayonet coupling plug of same size and insert polarization.
- Performance:  
Hermeticity -  $<1 \times 10^{-7}$  cc/sec @ 1 atm differential.  
Dielectric withstanding voltage - Consult factory or MIL-STD-1669.  
Insulation resistance - 5000 megohms min @500VDC.
- Metric Dimensions (mm) are indicated in parentheses.

**230-014**  
**MIL-DTL-26482 Series I Type Hermetic**  
**Bayonet Coupling Solder Mount Receptacle**  
**MS3113 Type**



MIL-DTL-26482  
Type

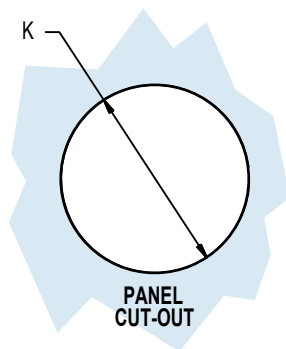

**D**

TABLE I: CONNECTOR AND CUT-OUT DIMENSIONS								
Shell Size	A Dia ± .016 (0.4)	B Dim +.031 (0.8) -000	C Dim +.016 (0.4) -.005 (0.1)	D Max Length of Mtg Diameter		E Dia +.001 (.0) -.005 (0.1)	L Max Length Overall	
				Pin	Socket		Pin	Socket
<b>8</b>	.625 (15.9)	.411 (10.4)	.031 (0.79)	.156 (4.0)	.215 (5.5)	.562 (14.3)	.828 (21.0)	.888 (22.6)
<b>10</b>	.750 (19.1)	.411 (10.4)	.031 (0.79)	.156 (4.0)	.215 (5.5)	.672 (17.1)	.828 (21.0)	.888 (22.6)
<b>12</b>	.844 (21.4)	.411 (10.4)	.031 (0.79)	.156 (4.0)	.215 (5.5)	.781 (19.8)	.828 (21.0)	.888 (22.6)
<b>14</b>	.969 (23.7)	.411 (10.4)	.031 (0.79)	.156 (4.0)	.215 (5.5)	.906 (23.0)	.828 (21.0)	.888 (22.6)
<b>16</b>	1.094 (27.8)	.411 (10.4)	.031 (0.79)	.156 (4.0)	.215 (5.5)	1.031 (26.2)	.828 (21.0)	.888 (22.6)
<b>18</b>	1.218 (30.9)	.411 (10.4)	.031 (0.79)	.156 (4.0)	.215 (5.5)	1.156 (29.4)	.828 (21.0)	.960 (24.4)
<b>20</b>	1.312 (33.3)	.473 (12.0)	.031 (0.79)	.156 (4.0)	.275 (7.0)	1.250 (31.8)	.891 (22.6)	.995 (25.3)
<b>22</b>	1.438 (36.5)	.473 (12.0)	.031 (0.79)	.188 (4.8)	.275 (7.0)	1.375 (34.9)	.921 (23.4)	.995 (25.3)
<b>24</b>	1.563 (39.7)	.506 (12.9)	.031 (0.79)	.188 (4.8)	.275 (7.0)	1.500 (38.1)	.921 (23.4)	.995 (25.3)

HERMETIC LEAK RATE MOD CODES	
Designator	Required Leak Rate
<b>-585A</b>	1 x 10 <sup>-10</sup> cc Helium per second
<b>-585B</b>	1 x 10 <sup>-9</sup> cc Helium per second
<b>-585C</b>	1 x 10 <sup>-8</sup> cc Helium per second

# 230-015

## MIL-DTL-26482 Series I Type Hermetic Bayonet Coupling Jam Nut Receptacle MS3114 Type

D

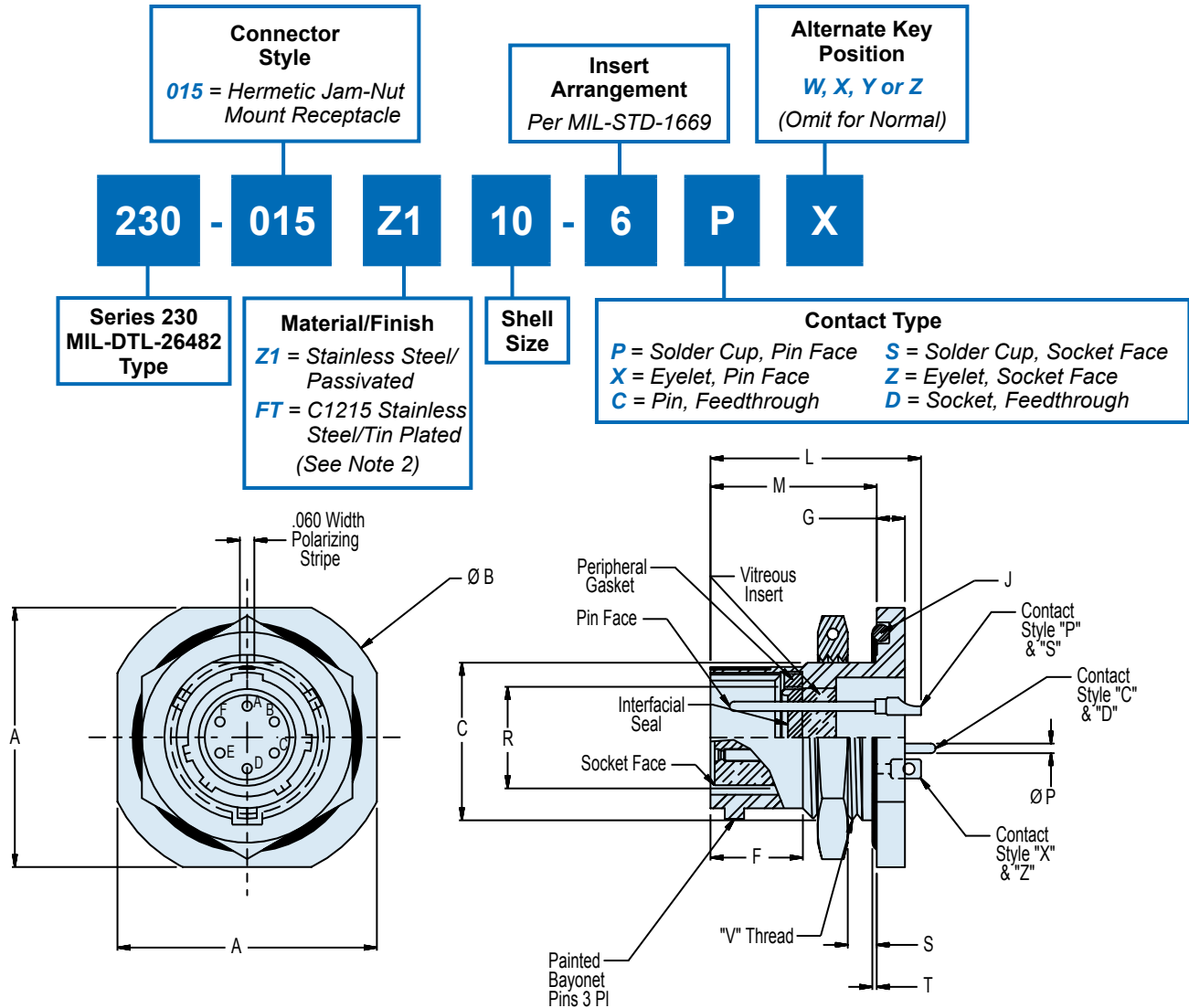

### APPLICATION NOTES

- To be identified with manufacturer's name, part number and date code, space permitting.
- Material/Finish:  
Shell and Jam Nut: Z1 - 304L stainless steel/passivate.  
FT - C1215 stainless steel/tin plated.  
Titanium and Inconel® available. Consult factory.  
Contacts - 52 Nickel alloy/gold plate.  
Bayonets - Stainless steel/passivate.  
Seals - Silicone elastomer/N.A.  
Insulation - Glass/N.A.
- Contact current rating - #20-5 Amps, #16-10 Amps, #12-17 Amps, #8-46 Amps.
- Consult factory and/or MIL-STD-1669 for arrangement and insert position options.
- Glenair 230-015 will mate with any QPL MIL-DTL-26482 Series I bayonet coupling plug of same size and insert polarization.
- Performance:  
Hermeticity -  $<1 \times 10^{-7}$  cc/sec @ 1 atmosphere differential.  
Dielectric withstanding voltage - Consult factory or MIL-STD-1669.  
Insulation resistance - 5000 megohms min @500VDC.
- Consult factory for feedthrough contact footprints.
- Metric Dimensions (mm) are indicated in parentheses.

**230-015**  
**MIL-DTL-26482 Series I Type Hermetic**  
**Bayonet Coupling Jam Nut Receptacle**  
**MS3114 Type**



MIL-DTL-26482  
Type

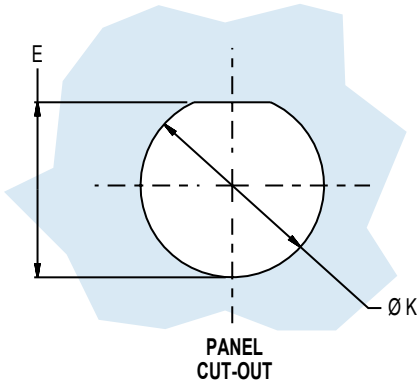

TABLE II	
Contact Size	Ø P
22D	.011 .015
20	.024 .028
16	.0635 .0615
12	.095 .093

HERMETIC LEAK RATE MOD CODES	
Designator	Required Leak Rate
-585A	1 x 10 <sup>-10</sup> cc Helium per second
-585B	1 x 10 <sup>-9</sup> cc Helium per second
-585C	1 x 10 <sup>-8</sup> cc Helium per second

**D**

TABLE I: CONNECTOR AND CUT-OUT DIMENSIONS (Continued Below)							
Shell Size	A Max	B Dia +.000 -.032 (0.8)	C Flat +.000 -.010 (0.3)	E +.010 -.005 (.13) Panel Flat Location	F Min	G ± .020 (0.5)	J O-Ring Seal MS29513-
8	.954 (24.2)	1.078 (27.4)	.530 (13.5)	.540 (13.72)	.384 (9.8)	.117 (3.0)	17
10	1.078 (27.4)	1.203 (30.6)	.665 (16.8)	.665 (16.76)	.384 (9.8)	.117 (3.0)	19
12	1.266 (32.2)	1.319 (33.5)	.818 (20.8)	.828 (21.03)	.384 (9.8)	.117 (3.0)	22
14	1.391 (35.3)	1.516 (38.5)	.942 (23.9)	.952 (24.18)	.384 (9.8)	.117 (3.0)	24
16	1.516 (38.5)	1.641 (41.7)	1.062 (27.0)	1.076 (27.33)	.384 (9.8)	.117 (3.0)	26
18	1.641 (41.7)	1.766 (44.9)	1.191 (30.3)	1.201 (30.51)	.384 (9.8)	.117 (3.0)	28
20	1.812 (46.0)	1.953 (49.6)	1.316 (33.4)	1.326 (33.68)	.446 (11.3)	.148 (3.8)	128
22	1.954 (49.6)	2.078 (52.8)	1.441 (36.6)	1.451 (36.86)	.446 (11.3)	.148 (3.8)	130
24	2.078 (52.8)	2.203 (56.0)	1.566 (39.8)	1.576 (40.03)	.479 (12.2)	.148 (3.8)	132

TABLE I (Continued): CONNECTOR AND CUT-OUT DIMENSIONS								
Shell Size	K DIA +.010-.005(.13) Panel Mounting Hole	L Max	M +.031 (0.8) -.000	R Max	S Panel Thickness		T O-Ring .011 (0.3)	V Thread UNEF-2A
					Min	Max		
8	.572 (14.53)	.875 (22.2)	.691 (17.6)	.329	.062 (1.6)	.125 (3.2)	.023 (0.6)	.5625-24
10	.697 (17.70)	.875 (22.2)	.691 (17.6)	.477	.062 (1.6)	.125 (3.2)	.023 (0.6)	.685-24
12	.885 (22.48)	.875 (22.2)	.691 (17.6)	.564	.062 (1.6)	.125 (3.2)	.023 (0.6)	.875-20
14	1.010 (25.65)	.875 (22.2)	.691 (17.6)	.689	.062 (1.6)	.125 (3.2)	.023 (0.6)	1.000-20
16	1.135 (28.83)	.875 (22.2)	.691 (17.6)	.814	.062 (1.6)	.125 (3.2)	.023 (0.6)	1.125-18
18	1.260 (32.00)	.875 (22.2)	.691 (17.6)	.907	.062 (1.6)	.125 (3.2)	.023 (0.6)	1.250-18
20	1.385 (35.18)	1.094 (27.8)	.879 (22.3)	1.039	.062 (1.6)	.250 (6.4)	.028 (0.7)	1.375-18
22	1.510 (38.35)	1.094 (27.8)	.879 (22.3)	1.164	.062 (1.6)	.250 (6.4)	.028 (0.7)	1.500-18
24	1.635 (41.53)	1.125 (28.6)	.912 (23.2)	1.289	.062 (1.6)	.250 (6.4)	.028 (0.7)	1.625-18

# 947-303 Narrow Flange Mount Bulkhead Feed-Thru MS3440 Type

D

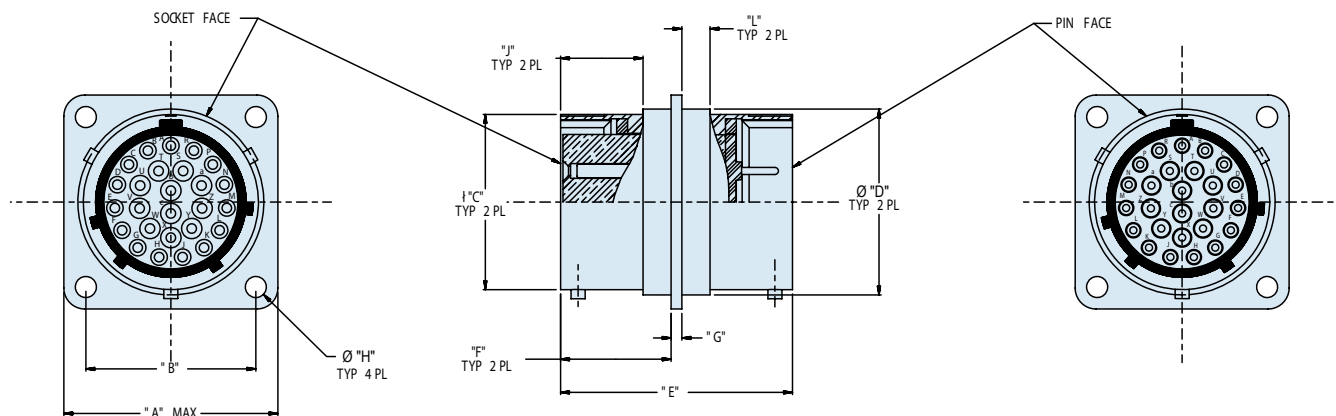
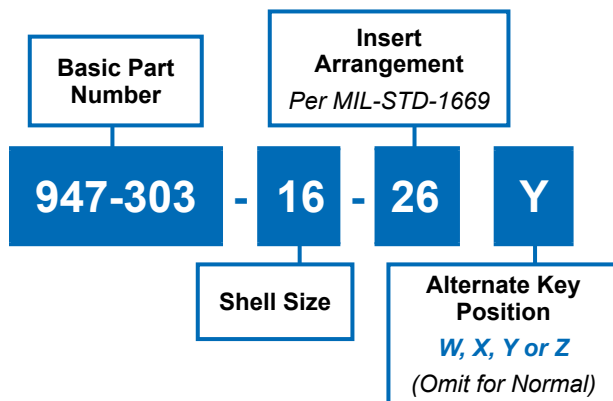

## APPLICATION NOTES

- To be identified with manufacturer's name, part number and date code, space permitting.
- Material/Finish:  
Shell: 300 CRES / passivate  
Titanium and Inconel® available. Consult factory.  
Contacts, Pin - Nickel alloy / gold plate  
Contacts, Socket - Copper alloy / gold plate  
Hoods, Sockets - 300 series CRES / passivate  
Bayonets - 300 series CRES / passivate  
Insulator - full glass / N.A.  
Insulator, Socket - high grade dielectric / N.A.  
Seals - Silicone elastomer / N.A.
- Glenair 947-303 will meet all performance requirements of MIL-DTL-26482
- Consult factory and/or MIL-STD-1669 for arrangement and insert position options.
- Glenair 947-303 will mate with any QPL manufacturer's MIL-DTL-26482 Series I or II plug with same shell size, arrangement and polarization, having opposite contact gender
- Glenair 947-303 is symmetrical on both sides of flange. There is no need to specify pin or sockets on one end.
- Metric Dimensions (mm) are indicated in parentheses.

**947-303**  
**Narrow Flange Mount Bulkhead Feed-Thru**  
**MS3440 Type**



MIL-DTL-26482  
Type

**TABLE I: CONNECTOR AND CUT-OUT DIMENSIONS (Continued Below)**

Shell Size	A	B	C Dia	D Dia ± .010	E Max	F	G	H
8	.828 (21.03)	.594 (15.1)	.474 (12.0) .468 (11.9)	.533 (13.5)	1.362 (34.6)	.692 (17.6) .672 (17.1)	.078 (2.0) .046 (1.2)	.120 (3.0)
10	.954 (24.2)	.719 (18.3)	.591 (15.0) .585 (14.9)	.650 (16.5)	1.362 (34.6)	.692 (17.6) .672 (17.1)	.078 (2.0) .046 (1.2)	.120 (3.0)
12	1.047 (26.6)	.812 (20.6)	.751 (19.1) .745 (18.9)	.810 (20.6)	1.362 (34.6)	.692 (17.6) .672 (17.1)	.078 (2.0) .046 (1.2)	.120 (3.0)
14	1.141 (29.0)	.906 (23.0)	.876 (22.3) .870 (22.1)	.935 (23.7)	1.362 (34.6)	.692 (17.6) .672 (17.1)	.078 (2.0) .046 (1.2)	.120 (3.0)
16	1.234 (31.3)	.969 (24.6)	1.001 (25.4) .995 (25.3)	1.060 (26.9)	1.362 (34.6)	.692 (17.6) .672 (17.1)	.078 (2.0) .046 (1.2)	.120 (3.0)
18	1.328 (33.7)	1.062 (27.0)	1.126 (28.6) 1.120 (28.4)	1.185 (30.1)	1.362 (34.6)	.692 (17.6) .672 (17.1)	.078 (2.0) .046 (1.2)	.120 (3.0)
20	1.453 (36.9)	1.156 (29.4)	1.251 (31.8) 1.245 (31.6)	1.310 (33.3)	1.506 (38.3)	.698 (17.7) .678 (17.2)	.110 (2.8) .078 (2.0)	.120 (3.0)
22	1.578 (40.1)	1.250 (31.8)	1.376 (35.0) 1.371 (34.8)	1.435 (36.4)	1.506 (38.3)	.698 (17.7) .678 (17.2)	.110 (2.8) .078 (2.0)	.120 (3.0)
24	1.703 (43.3)	1.375 (34.9)	1.501 (38.1) 1.495 (38.0)	1.560 (39.4)	1.506 (38.3)	.698 (17.7) .678 (17.2)	.110 (2.8) .078 (2.0)	.147 (3.7)

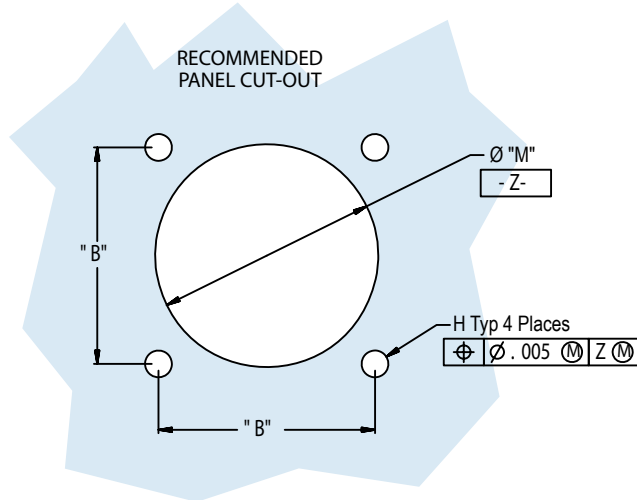

HERMETIC LEAK RATE MOD CODES	
Designator	Required Leak Rate
-585A	1 x 10 <sup>-10</sup> cc Helium per second
-585B	1 x 10 <sup>-9</sup> cc Helium per second
-585C	1 x 10 <sup>-8</sup> cc Helium per second

**TABLE I (Continued)**

Shell Size	J Minimum	L	M Dia. ± .005
8	.460 (11.7)	.212 (5.4)	.570 (14.5)
10	.460 (11.7)	.212 (5.4)	.680 (17.3)
12	.460 (11.7)	.212 (5.4)	.789 (20.0)
14	.460 (11.7)	.212 (5.4)	.914 (23.2)
16	.460 (11.7)	.212 (5.4)	1.039 (26.4)
18	.460 (11.7)	.212 (5.4)	1.164 (29.6)
20	.428 (10.9)	.250 (6.4)	1.258 (32.0)
22	.428 (10.9)	.250 (6.4)	1.383 (35.1)
24	.428 (10.9)	.250 (6.4)	1.508 (38.3)



**230-035**  
**MIL-DTL-26482 Series I Type Hermetic**  
**Bayonet Coupling Narrow Flange Mount Receptacle**  
**MS3112 Type**

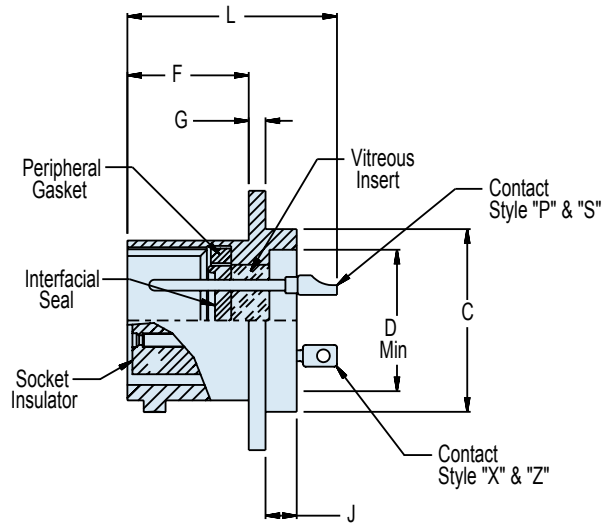
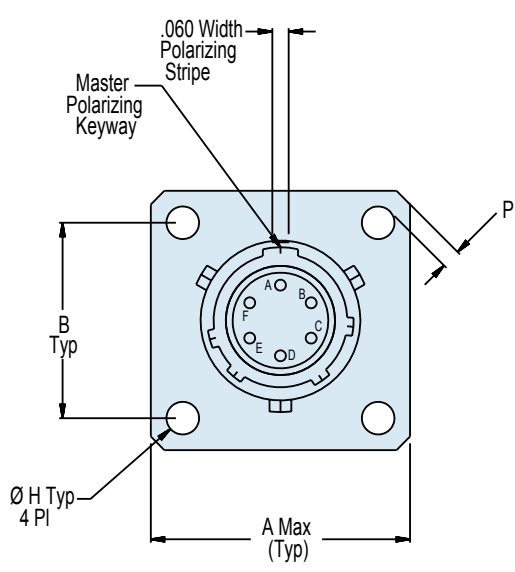
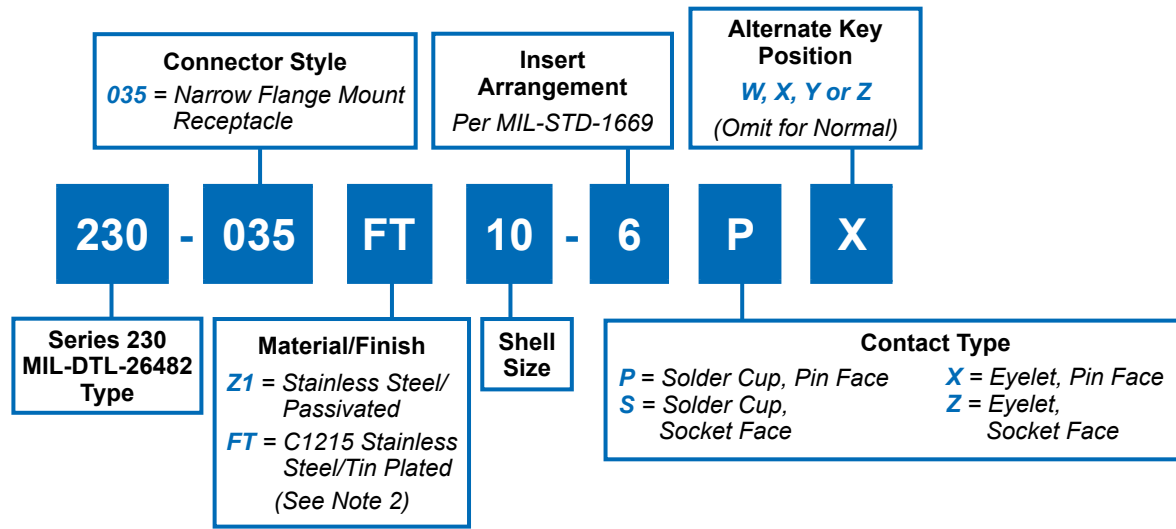

**APPLICATION NOTES**

- |   |   |
|---|---|
| <ol style="list-style-type: none"> <li>1. To be identified with manufacturer's name, part number and date code, space permitting.</li> <li>2. Material/Finish:<br/>                     Shell: Z1 - 304L stainless steel/passivate.<br/>                     FT - C1215 stainless steel/tin plated.<br/>                     Titanium and Inconel® available. Consult factory.<br/>                     Contacts - 52 Nickel alloy/gold plate.<br/>                     Bayonets - Stainless steel/passivate.<br/>                     Seals - Silicone elastomer/N.A.<br/>                     Insulation - Glass/N.A.<br/>                     Socket insulator - Rigid dielectric/N.A.<br/>                     Socket Contacts - Copper alloy/gold plated.</li> </ol> | <ol style="list-style-type: none"> <li>3. Glenair 230-035 will mate with any QPL MIL-DTL-26482 Series I bayonet coupling plug of same size and insert polarization.</li> <li>4. Performance:<br/>                     Hermeticity - <math>&lt;1 \times 10^{-7}</math> cc/sec @ 1 atmosphere differential.<br/>                     Dielectric withstanding voltage - Consult factory or MIL-STD-1669.<br/>                     Insulation resistance - 5000 megohms min @500VDC.</li> <li>5. Consult factory or MIL-STD-1669 for arrangement and insert position options.</li> <li>6. Metric Dimensions (mm) are indicated in parentheses.</li> </ol> |
|---|---|



**230-035**  
**MIL-DTL-26482 Series I Type Hermetic**  
**Bayonet Coupling Narrow Flange Mount Receptacle**  
**MS3112 Type**



MIL-DTL-26482  
Type

D

HERMETIC LEAK RATE MOD CODES	
Designator	Required Leak Rate
-585A	1 x 10 <sup>-10</sup> cc Helium per second
-585B	1 x 10 <sup>-9</sup> cc Helium per second
-585C	1 x 10 <sup>-8</sup> cc Helium per second

TABLE I: CONNECTOR AND CUT-OUT DIMENSIONS									
Shell Size	A Max Length	B Mounting Holes $\varnothing$ to $\varnothing$	C Dia Mounting Locator	D Dia Min	F Mounting Flange Location	G Flange Thickness	J Max	L Max Overall Length	P Min Edge Distance
8	.828 (21.0)	.594 (15.1)	.469/.422 (11.9/10.7)	.403 (10.2)	.462/.431 (11.7/10.9)	.078/.046 (2.0/1.2)	.354 (9.0)	.978 (24.8)	.035 (0.89)
10	.954 (24.2)	.719 (18.3)	.593/.546 (15.1/13.9)	.515 (13.1)	.462/.431 (11.7/10.9)	.078/.046 (2.0/1.2)	.354 (9.0)	.978 (24.8)	.035 (0.89)
12	1.047 (26.6)	.812 (20.6)	.719/.672 (18.3/17.1)	.630 (16.0)	.462/.431 (11.7/10.9)	.078/.046 (2.0/1.2)	.354 (9.0)	.978 (24.8)	.035 (0.89)
14	1.141 (29.0)	.906 (23.0)	.843/.796 (21.4/20.2)	.755 (19.2)	.462/.431 (11.7/10.9)	.078/.046 (2.0/1.2)	.354 (9.0)	.978 (24.8)	.035 (0.89)
16	1.234 (31.3)	.969 (24.6)	.969/.922 (24.6/23.4)	.880 (22.4)	.462/.431 (11.7/10.9)	.078/.046 (2.0/1.2)	.354 (9.0)	.978 (24.8)	.035 (0.89)
18	1.328 (33.7)	1.062 (27.0)	1.093/1.046 (27.8/26.6)	.980 (24.9)	.462/.431 (11.7/10.9)	.078/.046 (2.0/1.2)	.354 (9.0)	.978 (24.8)	.035 (0.89)
20	1.453 (36.9)	1.156 (29.4)	1.219/1.172 (31.0/29.8)	1.105 (28.1)	.587/.556 (14.9/14.1)	.110/.078 (2.8/2.0)	.417 (10.6)	1.196 (29.9)	.050 (1.27)
22	1.578 (40.1)	1.250 (31.8)	1.343/1.296 (34.1/32.9)	1.230 (31.2)	.587/.556 (14.9/14.1)	.110/.078 (2.8/2.0)	.417 (10.6)	1.196 (29.9)	.050 (1.27)
24	1.703 (43.3)	1.375 (34.9)	1.469/1.422 (37.3/36.1)	1.385 (35.2)	.587/.556 (14.9/14.1)	.110/.078 (2.8/2.0)	.445 (11.3)	1.196 (29.9)	.050 (1.27)



**230-016**  
**MIL-DTL-26482 Series II Type Hermetic**  
**Bayonet Coupling Narrow Flange Mount Receptacle**  
**MS3440 Type**

**Connector Style**  
**016 = Hermetic Narrow Flange Mount Receptacle**

**Insert Arrangement**  
 Per MIL-STD-1669

**Alternate Key Position**  
**W, X, Y or Z**  
 (Omit for Normal)

**230 - 016 FT 10 - 6 P X**

**Series 230**  
**MIL-DTL-26482**  
**Type**

**Material/Finish**  
**Z1 = Stainless Steel/Passivated**  
**FT = C1215 Stainless Steel/Tin Plated**  
 (See Note 2)

**Shell Size**

**Contact Type**  
**P = Solder Cup, Pin Face**  
**X = Eyelet, Pin Face**  
**S = Socket, Solder Cup**  
**Z = Socket, Eyelet**

HERMETIC LEAK RATE MOD CODES	
Designator	Required Leak Rate
-585A	1 x 10 <sup>-10</sup> cc Helium per second
-585B	1 x 10 <sup>-9</sup> cc Helium per second
-585C	1 x 10 <sup>-8</sup> cc Helium per second

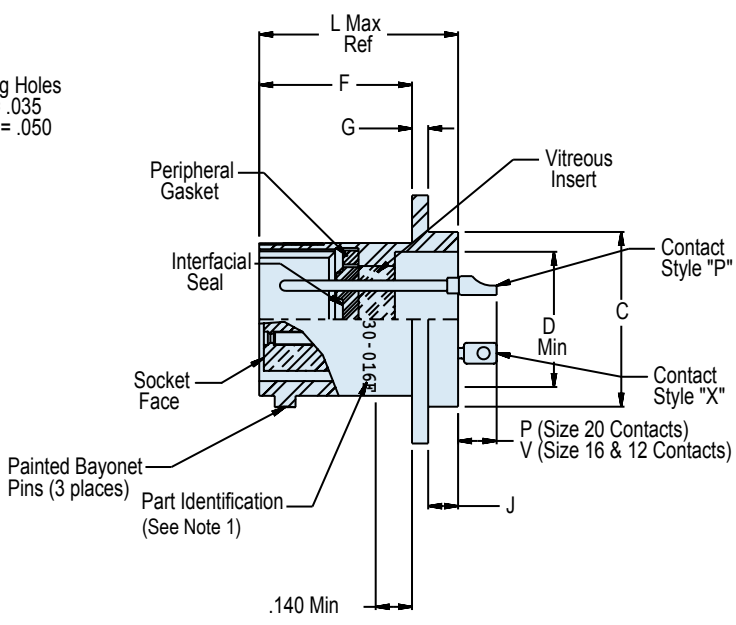
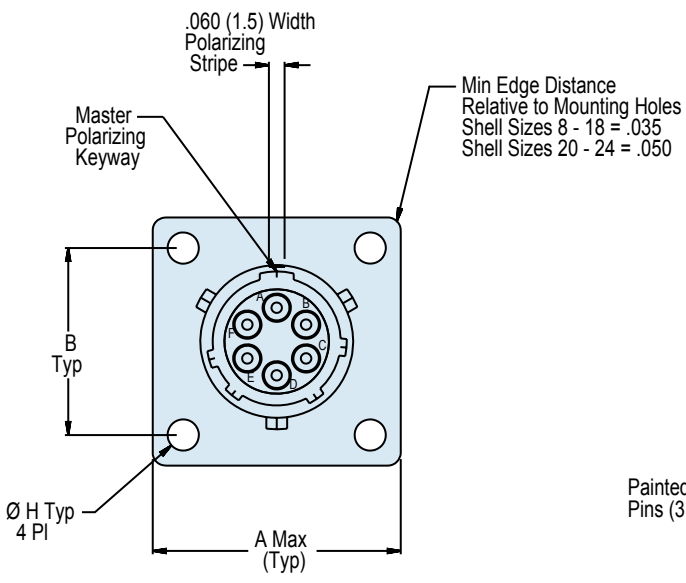

**APPLICATION NOTES**

- To be identified with manufacturer's name, part number and date code, space permitting.
- Material/Finish:  
 Shell: Z1 - 304L stainless steel/passivate.  
 FT - C1215 stainless steel/tin plated.  
 Titanium and Inconel® available. Consult factory.  
 Contacts - 52 Nickel alloy/gold plate.  
 Sockets - Copper alloy, gold plated.  
 Bayonets - Stainless steel/passivate.  
 Seals - Silicone elastomer/N.A.  
 Insulation - Glass/N.A.; Socket: Rigid dielectric/N.A.
- Consult factory and/or MIL-STD-1669 for arrangement and insert position options.
- Glenair 230-016 will mate with any QPL MIL-DTL-26482 Series II bayonet coupling plug of same size and insert polarization.
- Performance:  
 Hermeticity - <1 x 10<sup>-7</sup> cc/sec @ 1 atm differential.  
 Dielectric withstanding voltage - Consult factory or MIL-STD-1669.  
 Insulation resistance - 5000 megohms min @500VDC.
- Metric Dimensions (mm) are indicated in parentheses.

**230-016**  
**MIL-DTL-26482 Series II Type Hermetic**  
**Bayonet Coupling Narrow Flange Mount Receptacle**  
**MS3440 Type**



MIL-DTL-26482  
Type

**D**

**TABLE I: CONNECTOR AND CUT-OUT DIMENSIONS (Continued Below)**

Shell Size	A	B	C Dia Mounting Locator	D Dia Min	F	G	H
8	.828 (21.03)	.594 (15.1)	.563/.557 (14.3/14.1)	.403 (10.2)	.598/.578 (15.2/14.7)	.078/.04 (2.0/1.0)	.120 (3.0)
10	.954 (24.2)	.719 (18.3)	.673/.667 (17.1/16.9)	.515 (13.1)	.598/.578 (15.2/14.7)	.078/.04 (2.0/1.0)	.120 (3.0)
12	1.047 (26.6)	.812 (20.6)	.782/.776 (19.9/19.7)	.630 (16.0)	.598/.578 (15.2/14.7)	.078/.04 (2.0/1.0)	.120 (3.0)
14	1.141 (29.0)	.906 (23.0)	.907/.901 (23.0/22.9)	.755 (19.2)	.598/.578 (15.2/14.7)	.078/.04 (2.0/1.0)	.120 (3.0)
16	1.234 (31.3)	.969 (24.6)	1.032/1.026 (26.2/26.1)	.880 (22.4)	.598/.578 (15.2/14.7)	.078/.04 (2.0/1.0)	.120 (3.0)
18	1.328 (33.7)	1.062 (27.0)	1.157/1.151 (29.4/29.2)	.980 (24.9)	.598/.578 (15.2/14.7)	.078/.04 (2.0/1.0)	.120 (3.0)
20	1.453 (36.9)	1.156 (29.4)	1.251/1.245 (31.8/31.6)	1.105 (28.1)	.660/.640 (16.8/16.3)	.110/.078 (2.8/2.0)	.120 (3.0)
22	1.578 (40.1)	1.250 (31.8)	1.376/1.371 (35.0/34.8)	1.230 (31.2)	.660/.640 (16.8/16.3)	.110/.078 (2.8/2.0)	.120 (3.0)
24	1.703 (43.3)	1.375 (34.9)	1.501/1.495 (38.1/38.0)	1.385 (35.2)	.660/.640 (16.8/16.3)	.110/.078 (2.8/2.0)	.147 (3.7)

**TABLE I (Continued): CONNECTOR AND CUT-OUT DIMENSIONS**

Shell Size	J	L	P	V	Panel Cut-Out Dia	Max. Weight (Lbs)
8	.125/.105 (3.2/2.7)	.801 (20.3)	.178/.118 (4.5/3.0)	.248/.188 (6.3/4.8)	.570 (14.5)	.038
10	.125/.105 (3.2/2.7)	.801 (20.3)	.178/.118 (4.5/3.0)	.248/.188 (6.3/4.8)	.680 (17.3)	.044
12	.125/.105 (3.2/2.7)	.801 (20.3)	.178/.118 (4.5/3.0)	.248/.188 (6.3/4.8)	.789 (20.0)	.052
14	.125/.105 (3.2/2.7)	.801 (20.3)	.178/.118 (4.5/3.0)	.248/.188 (6.3/4.8)	.914 (23.2)	.070
16	.125/.105 (3.2/2.7)	.801 (20.3)	.178/.118 (4.5/3.0)	.248/.188 (6.3/4.8)	1.039 (26.4)	.085
18	.125/.105 (3.2/2.7)	.801 (20.3)	.178/.118 (4.5/3.0)	.248/.188 (6.3/4.8)	1.164 (29.6)	.098
20	.125/.105 (3.2/2.7)	.863 (21.9)	.178/.118 (4.5/3.0)	.248/.188 (6.3/4.8)	1.258 (32.0)	.110
22	.125/.105 (3.2/2.7)	.895 (22.7)	.146/.086 (3.7/2.2)	.216/.156 (5.5/4.0)	1.383 (35.1)	.150
24	.125/.105 (3.2/2.7)	.895 (22.7)	.146/.086 (3.7/2.2)	.216/.156 (5.5/4.0)	1.508 (38.3)	.280



**230-017**  
**MIL-DTL-26482 Series II Type Hermetic**  
**Bayonet Coupling Wide Flange Mount Receptacle**  
**MS3442 Type**

**Connector Style**  
**017 = Hermetic Wide Flange Mount Receptacle**

**Insert Arrangement**  
**Per MIL-STD-1669**

**Alternate Key Position**  
**W, X, Y or Z**  
**(Omit for Normal)**

**230 - 017 FT 10 - 6 P X**

**Series 230 MIL-DTL-26482 Type**

**Material/Finish**  
**Z1 = Stainless Steel/Passivated**  
**FT = C1215 Stainless Steel/Tin Plated (See Note 2)**

**Shell Size**

**Contact Type**  
**P = Solder Cup, Pin Face**  
**X = Eyelet, Pin Face**  
**S = Socket, Solder Cup**  
**Z = Socket, Eyelet**

HERMETIC LEAK RATE MOD CODES	
Designator	Required Leak Rate
-585A	1 x 10 <sup>-10</sup> cc Helium per second
-585B	1 x 10 <sup>-9</sup> cc Helium per second
-585C	1 x 10 <sup>-8</sup> cc Helium per second

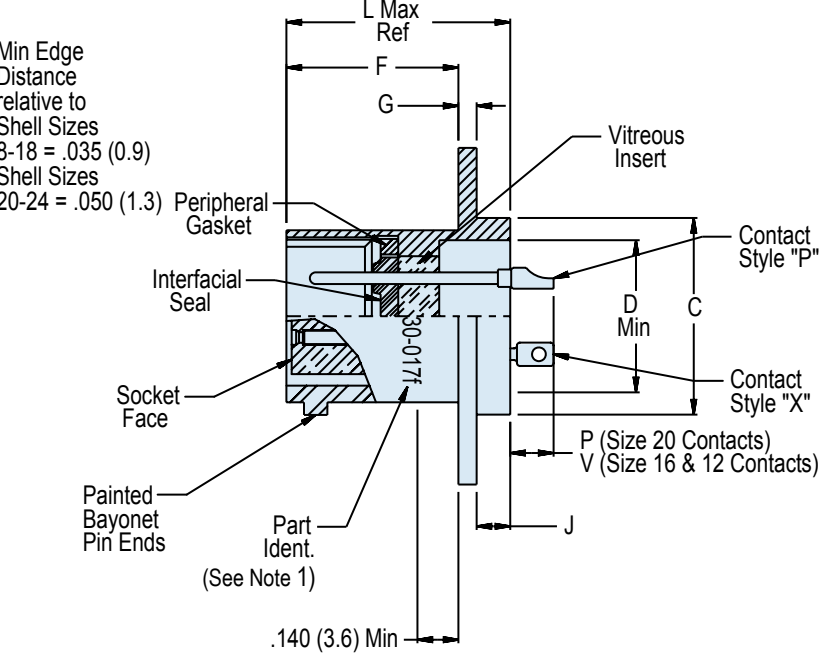
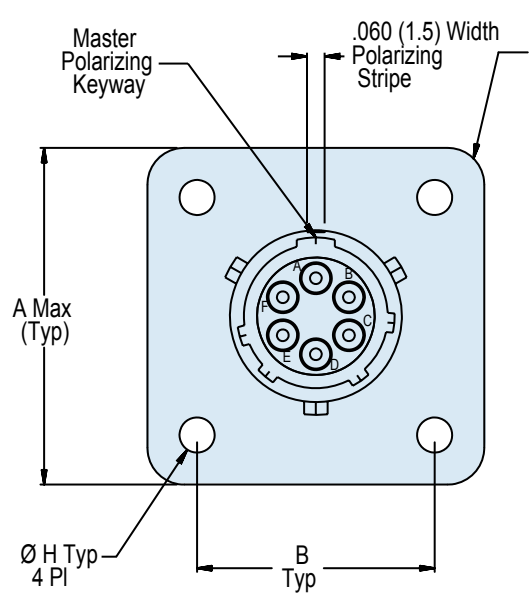

**APPLICATION NOTES**

- To be identified with manufacturer's name, part number and date code, space permitting.
- Material/Finish:  
Shell: Z1 - 304L stainless steel/passivate.  
FT - C1215 stainless steel/tin plated.  
Titanium and Inconel® available. Consult factory.  
Contacts - 52 Nickel alloy/gold plate.  
Sockets - Copper alloy, gold plated.  
Bayonets - Stainless steel/passivate.  
Seals - Silicone elastomer/N.A.  
Insulation - Glass/N.A.; Socket: Rigid dielectric/N.A.
- Consult factory and/or MIL-STD-1669 for arrangement and insert position options.
- Glenair 230-017 will mate with any QPL MIL-DTL-26482 Series II bayonet coupling plug of same size and insert polarization.
- Performance:  
Hermeticity - <1 x 10<sup>-7</sup> cc/sec @ 1 atm differential.  
Dielectric withstanding voltage - Consult factory or MIL-STD-1669.  
Insulation resistance - 5000 megohms min @500VDC.
- Metric Dimensions (mm) are indicated in parentheses.

**230-017**  
**MIL-DTL-26482 Series II Type Hermetic**  
**Bayonet Coupling Wide Flange Mount Receptacle**  
**MS3442 Type**



MIL-DTL-26482  
Type

**D**

**TABLE I: CONNECTOR AND CUT-OUT DIMENSIONS (Continued Below)**

Shell Size	A	B	C Dia Mounting Locator	D Dia Min	F	G	H
8	1.065 (27.1)	.734 (18.6)	.563/.557 (14.3/14.1)	.403 (10.2)	.598/.578 (15.2/14.7)	.078/.046 (2.0/1.2)	.150 (3.8)
10	1.141 (29.0)	.812 (20.6)	.673/.667 (17.1/16.9)	.515 (13.1)	.598/.578 (15.2/14.7)	.078/.046 (2.0/1.2)	.150 (3.8)
12	1.266 (32.2)	.938 (23.8)	.782/.776 (19.9/19.7)	.630 (16.0)	.598/.578 (15.2/14.7)	.078/.046 (2.0/1.2)	.150 (3.8)
14	1.360 (34.5)	1.031 (26.2)	.907/.901 (23.0/22.9)	.755 (19.2)	.598/.578 (15.2/14.7)	.078/.046 (2.0/1.2)	.150 (3.8)
16	1.453 (36.9)	1.125 (28.6)	1.032/1.026 (26.2/26.1)	.880 (22.4)	.598/.578 (15.2/14.7)	.078/.046 (2.0/1.2)	.150 (3.8)
18	1.532 (38.9)	1.203 (30.6)	1.157/1.151 (29.4/29.2)	.980 (24.9)	.598/.578 (15.2/14.7)	.078/.046 (2.0/1.2)	.150 (3.8)
20	1.688 (42.9)	1.297 (32.9)	1.251/1.245 (31.8/31.6)	1.105 (28.1)	.660/.640 (16.8/16.3)	.110/.078 (2.8/2.0)	.150 (3.8)
22	1.766 (44.9)	1.375 (34.9)	1.376/1.371 (35.0/34.8)	1.230 (31.2)	.660/.640 (16.8/16.3)	.110/.078 (2.8/2.0)	.150 (3.8)
24	1.891 (48.0)	1.500 (38.1)	1.501/1.495 (38.1/38.0)	1.385 (35.2)	.660/.640 (16.8/16.3)	.110/.078 (2.8/2.0)	.150 (3.8)

**TABLE I (Continued): CONNECTOR AND CUT-OUT DIMENSIONS**

Shell Size	J	L	P	V	Panel Cut-Out Dia
8	.125/.105 (3.2/2.7)	.801 (20.3)	.178/.118 (4.5/3.0)	.248/.188 (6.3/4.8)	.570 (14.5)
10	.125/.105 (3.2/2.7)	.801 (20.3)	.178/.118 (4.5/3.0)	.248/.188 (6.3/4.8)	.680 (17.3)
12	.125/.105 (3.2/2.7)	.801 (20.3)	.178/.118 (4.5/3.0)	.248/.188 (6.3/4.8)	.789 (20.0)
14	.125/.105 (3.2/2.7)	.801 (20.3)	.178/.118 (4.5/3.0)	.248/.188 (6.3/4.8)	.914 (23.2)
16	.125/.105 (3.2/2.7)	.801 (20.3)	.178/.118 (4.5/3.0)	.248/.188 (6.3/4.8)	1.039 (26.4)
18	.125/.105 (3.2/2.7)	.801 (20.3)	.178/.118 (4.5/3.0)	.248/.188 (6.3/4.8)	1.164 (29.6)
20	.125/.105 (3.2/2.7)	.863 (21.9)	.178/.118 (4.5/3.0)	.248/.188 (6.3/4.8)	1.258 (32.0)
22	.125/.105 (3.2/2.7)	.895 (22.7)	.146/.086 (3.7/2.2)	.216/.156 (5.5/4.0)	1.383 (35.1)
24	.125/.105 (3.2/2.7)	.895 (22.7)	.146/.086 (3.7/2.2)	.216/.156 (5.5/4.0)	1.508 (38.3)



**230-018**  
**MIL-DTL-26482 Series II Type Hermetic**  
**Bayonet Coupling Solder Flange Mount Receptacle**  
**MS3443 Type**

**D**

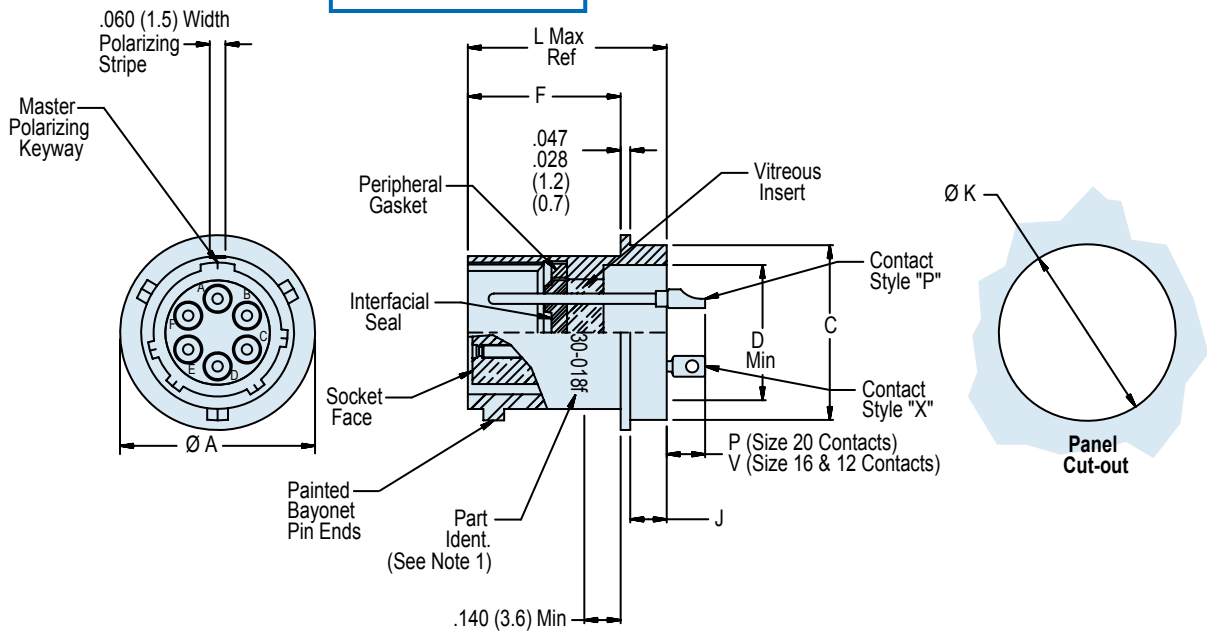
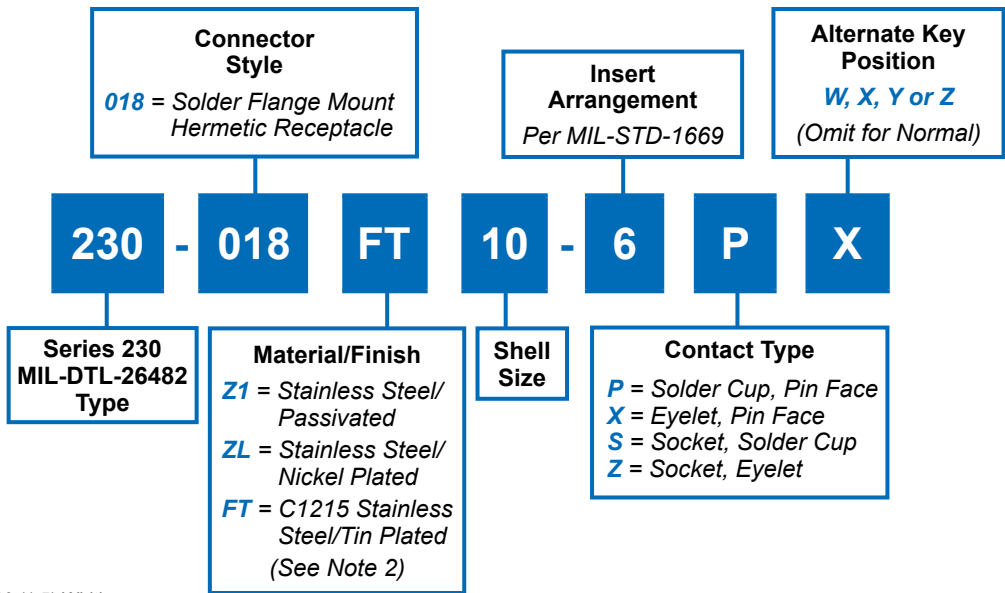

**APPLICATION NOTES**

- To be identified with manufacturer's name, part number and date code, space permitting.
- Material/Finish:  
 Shell - Z1 - Stainless steel/passivate.  
 ZL - Stainless steel/nickel plated.  
 FT = C1215 Stainless Steel/Tin Plated  
 Titanium and Inconel® available. Consult factory.  
 Contacts - 52 Nickel alloy/gold plate.  
 Sockets - Copper alloy, gold plated.  
 Bayonets - Stainless steel/passivate.  
 Seals - Silicone elastomer/N.A.  
 Insulation - Glass/N.A.; Socket: Rigid Dielectric/N.A.
- Consult factory and/or MIL-STD-1669 for arrangement and insert position options.
- Glenair 230-018 will mate with any QPL MIL-DTL-26482 Series II bayonet coupling plug of same size and insert polarization.
- Performance:  
 Hermeticity - <math>1 \times 10^{-7}</math> cc/sec @ 1 atm differential.  
 Dielectric withstanding voltage - Consult factory or MIL-STD-1669.  
 Insulation resistance - 5000 megohms min @500VDC.
- Metric Dimensions (mm) are indicated in parentheses.

**230-018**  
**MIL-DTL-26482 Series II Type Hermetic**  
**Bayonet Coupling Solder Flange Mount Receptacle**  
**MS3443 Type**



MIL-DTL-26482  
Type

HERMETIC LEAK RATE MOD CODES	
Designator	Required Leak Rate
-585A	1 x 10 <sup>-10</sup> cc Helium per second
-585B	1 x 10 <sup>-9</sup> cc Helium per second
-585C	1 x 10 <sup>-8</sup> cc Helium per second

**D**

**TABLE I: CONNECTOR AND CUT-OUT DIMENSIONS**

Shell Size	A Dia ± .010 (0.3)	C Dia Mounting Locator	D Dia Min	F	J	K	L	P	V	Max Weight (Lbs.)
8	.625 (15.9)	.563/.557 (14.3/14.1)	.403 (10.2)	.598/.578 (15.2/14.7)	.156/.116 (4.0/2.9)	.570 (14.5)	.801 (20.3)	.178/.118 (4.5/3.0)	.248/.188 (6.3/4.8)	.0310
10	.750 (19.1)	.673/.667 (17.1/16.9)	.515 (13.1)	.598/.578 (15.2/14.7)	.156/.116 (4.0/2.9)	.680 (17.3)	.801 (20.3)	.178/.118 (4.5/3.0)	.248/.188 (6.3/4.8)	.0340
12	.844 (21.4)	.782/.776 (19.9/19.7)	.630 (16.0)	.598/.578 (15.2/14.7)	.156/.116 (4.0/2.9)	.789 (20.0)	.801 (20.3)	.178/.118 (4.5/3.0)	.248/.188 (6.3/4.8)	.0400
14	.969 (24.6)	.907/.901 (23.0/22.9)	.755 (19.2)	.598/.578 (15.2/14.7)	.156/.116 (4.0/2.9)	.914 (23.2)	.801 (20.3)	.178/.118 (4.5/3.0)	.248/.188 (6.3/4.8)	.0510
16	1.094 (27.8)	1.032/1.026 (26.2/26.1)	.880 (22.4)	.598/.578 (15.2/14.7)	.156/.116 (4.0/2.9)	1.039 (26.4)	.801 (20.3)	.178/.118 (4.5/3.0)	.248/.188 (6.3/4.8)	.0620
18	1.218 (30.9)	1.157/1.151 (29.4/29.2)	.980 (24.9)	.598/.578 (15.2/14.7)	.156/.116 (4.0/2.9)	1.164 (29.6)	.801 (20.3)	.178/.118 (4.5/3.0)	.248/.188 (6.3/4.8)	.0820
20	1.312 (33.3)	1.251/1.245 (31.8/31.6)	1.105 (28.1)	.660/.640 (16.8/16.3)	.156/.116 (4.0/2.9)	1.258 (32.0)	.863 (21.9)	.178/.118 (4.5/3.0)	.248/.188 (6.3/4.8)	.1000
22	1.438 (36.5)	1.376/1.371 (35.0/34.8)	1.230 (31.2)	.660/.640 (16.8/16.3)	.188/.148 (4.8/3.8)	1.383 (35.1)	.895 (22.7)	.146/.086 (3.7/2.2)	.216/.156 (5.5/4.0)	.1150
24	1.564 (39.7)	1.501/1.495 (38.1/38.0)	1.385 (35.2)	.660/.640 (16.8/16.3)	.188/.148 (4.8/3.8)	1.508 (38.3)	.895 (22.7)	.146/.086 (3.7/2.2)	.216/.156 (5.5/4.0)	.2680





**230-019**  
**MIL-DTL-26482 Series II Type Hermetic**  
**Quick Release Bayonet Receptacle**  
**Single Hole Jam-Nut Mount MS3449 Type**

**Connector Style**  
**019 = Hermetic Jam-Nut Single Hole Mount Receptacle**

**Insert Arrangement**  
 Per MIL-STD-1669

**Alternate Key Position**  
**W, X, Y or Z**  
 (Omit for Normal)

**230 - 019 FT 10 - 6 P X**

**Series 230 MIL-DTL-26482 Type**

**Material/Finish**  
**Z1 = Stainless Steel/Passivated**  
**FT = C1215 Stainless Steel/Tin Plated (See Note 2)**

**Shell Size**

**Contact Type**  
**P = Solder Cup, Pin Face**  
**X = Eyelet, Pin Face**  
**S = Socket, Solder Cup**  
**Z = Socket, Eyelet**

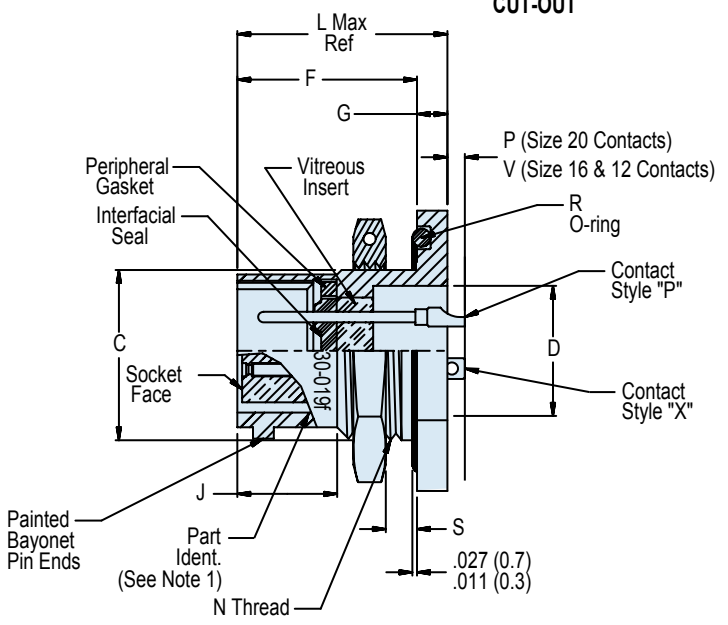
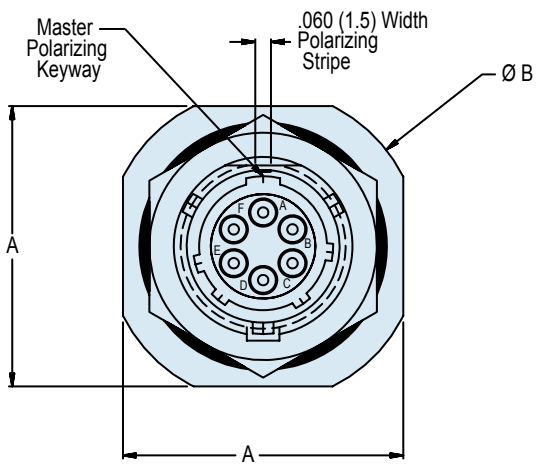
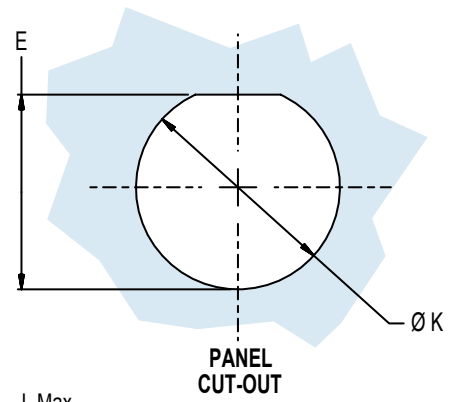

HERMETIC LEAK RATE MOD CODES	
Designator	Required Leak Rate
-585A	1 x 10 <sup>-10</sup> cc Helium per second
-585B	1 x 10 <sup>-9</sup> cc Helium per second
-585C	1 x 10 <sup>-8</sup> cc Helium per second

**APPLICATION NOTES**

- To be identified with manufacturer's name, part number and date code, space permitting.
- Material/Finish:  
 Shell: Z1 - 304L stainless steel/passivate.  
 FT - C1215 stainless steel/tin plated.  
 Titanium and Inconel® available. Consult factory.  
 Contacts - 52 Nickel alloy/gold plate.  
 Sockets - Copper alloy, gold plated.  
 Bayonets - Stainless steel/passivate.  
 Seals - Silicone elastomer/N.A.  
 Insulation - Glass/N.A.; Socket: Rigid dielectric/N.A.
- Consult factory and/or MIL-STD-1669 for arrangement and insert position options.
- Glenair 230-019 will mate with any QPL MIL-DTL-26482 Series II bayonet coupling plug of same size and insert polarization.
- Performance:  
 Hermeticity - <1 x 10<sup>-7</sup> cc/sec @ 1 atm differential.  
 Dielectric withstanding voltage - Consult factory or MIL-STD-1669.  
 Insulation resistance - 5000 megohms min @500VDC.
- Metric Dimensions (mm) are indicated in parentheses.

**230-019**  
**MIL-DTL-26482 Series II Type Hermetic**  
**Quick Release Bayonet Receptacle**  
**Single Hole Jam-Nut Mount MS3449 Type**



MIL-DTL-26482  
Type

**TABLE I: CONNECTOR AND CUT-OUT DIMENSIONS (Continued Below)**

Shell Size	A Length + .000 - .031 (+0 -0.8)	B Dia + .000 - .031 (+0 -0.8) Across Flange Corner	C +.000 - .010 (+0 -0.3) Mounting Flat	D Dia Min	E Panel Flat Location	F Mounting Flange Location	G Mounting Flange Thickness	J To Thread Chamfer ± .010 (0.3)	K + .010 - .005 (+0.3 -0.1) Panel Mounting Hole
8	.954 (24.2)	1.078 (27.4)	.530 (13.5)	.403 (10.2)	.536 (13.6)	.707/.691 (18.0/17.6)	.113/.097 (2.9/2.5)	.368 (9.3)	.572 (14.5)
10	1.078 (27.4)	1.203 (30.6)	.655 (16.6)	.515 (13.1)	.661 (16.8)	.707/.691 (18.0/17.6)	.113/.097 (2.9/2.5)	.368 (9.3)	.697 (17.7)
12	1.266 (32.2)	1.391 (35.3)	.818 (20.8)	.630 (16.0)	.824 (20.9)	.707/.691 (18.0/17.6)	.113/.097 (2.9/2.5)	.368 (9.3)	.885 (22.5)
14	1.391 (35.3)	1.516 (38.5)	.942 (23.9)	.755 (19.2)	.948 (24.1)	.707/.691 (18.0/17.6)	.113/.097 (2.9/2.5)	.368 (9.3)	1.010 (25.7)
16	1.516 (38.5)	1.641 (41.7)	1.062 (27.0)	.880 (22.4)	1.072 (27.2)	.707/.691 (18.0/17.6)	.113/.097 (2.9/2.5)	.368 (9.3)	1.135 (28.8)
18	1.641 (41.7)	1.766 (44.9)	1.191 (30.3)	.980 (24.9)	1.197 (30.4)	.707/.691 (18.0/17.6)	.113/.097 (2.9/2.5)	.368 (9.3)	1.260 (32.0)
20	1.828 (46.4)	1.954 (49.6)	1.316 (33.4)	1.105 (28.1)	1.322 (33.6)	.772/.754 (19.6/19.2)	.148/.128 (3.8/3.3)	.368 (9.3)	1.385 (35.2)
22	1.954 (49.6)	2.078 (52.8)	1.441 (36.6)	1.230 (31.2)	1.447 (36.8)	.772/.754 (19.6/19.2)	.148/.128 (3.8/3.3)	.368 (9.3)	1.510 (38.4)
24	2.078 (52.8)	2.203 (56.0)	1.566 (39.8)	1.385 (35.2)	1.572 (39.9)	.803/.785 (20.4/19.9)	.148/.128 (3.8/3.3)	.395 (10.0)	1.635 (41.5)

**D**

**TABLE I (Continued): CONNECTOR AND CUT-OUT DIMENSIONS**

Shell Size	L Overall Length	N UNEF-2A Mounting Thread	P	R O-Ring Seal MS29513-	S Panel Thickness		V	Max. Weight (Lbs)
					Min	Max		
8	.820 (20.8)	.5625-24	.134/.074 (3.4/1.9)	16	.062 (1.6)	.187 (4.7)	.204/.144 (5.2/3.7)	.0430
10	.820 (20.8)	.6875-24	.134/.074 (3.4/1.9)	18	.062 (1.6)	.187 (4.7)	.204/.144 (5.2/3.7)	.0610
12	.820 (20.8)	.875-20	.134/.074 (3.4/1.9)	21	.062 (1.6)	.187 (4.7)	.204/.144 (5.2/3.7)	.0880
14	.820 (20.8)	1.000-20	.134/.074 (3.4/1.9)	23	.062 (1.6)	.187 (4.7)	.204/.144 (5.2/3.7)	.1100
16	.820 (20.8)	1.125-18	.134/.074 (3.4/1.9)	25	.062 (1.6)	.187 (4.7)	.204/.144 (5.2/3.7)	.1310
18	.820 (20.8)	1.250-18	.134/.074 (3.4/1.9)	27	.062 (1.6)	.187 (4.7)	.204/.144 (5.2/3.7)	.1720
20	.920 (23.4)	1.375-18	.099/.039 (2.5/1.0)	29	.062 (1.6)	.250 (6.4)	.169/.109 (4.3/2.8)	.2110
22	.920 (23.4)	1.500-18	.099/.039 (2.5/1.0)	30	.062 (1.6)	.250 (6.4)	.169/.109 (4.3/2.8)	.2420
24	.951 (24.2)	1.625-18	.099/.039 (2.5/1.0)	31	.062 (1.6)	.250 (6.4)	.139/.079 (3.5/2.0)	.2930



230-020

**MIL-DTL-26482 Series II Type Hermetic Bayonet Coupling Solder Mount Receptacle with Crimp Removable Contacts • MS3473 Type**

D

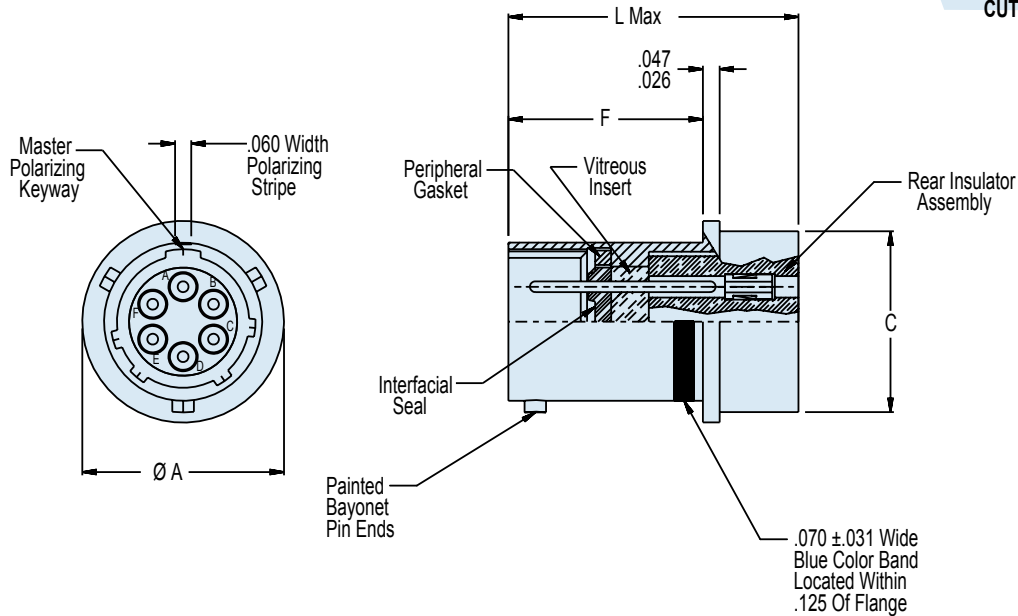
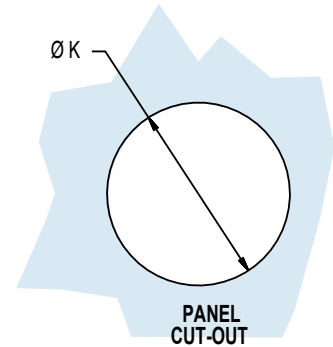
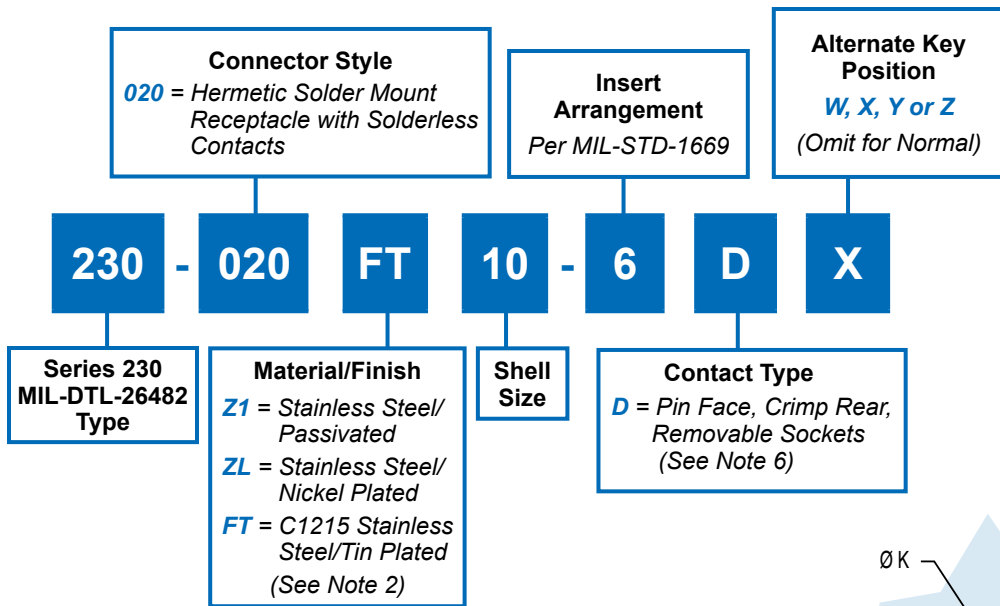

230-020

**MIL-DTL-26482 Series II Type Hermetic  
Bayonet Coupling Solder Mount Receptacle  
with Crimp Removable Contacts • MS3473 Type**



MIL-DTL-26482  
Type

**D**

HERMETIC LEAK RATE MOD CODES	
Designator	Required Leak Rate
-585A	1 x 10 <sup>-10</sup> cc Helium per second
-585B	1 x 10 <sup>-9</sup> cc Helium per second
-585C	1 x 10 <sup>-8</sup> cc Helium per second

TABLE I: CONNECTOR AND CUT-OUT DIMENSIONS					
Shell Size	A Dia Ø.010 (0.3)	C Dia	F	K	L Max
8	.625 (15.9)	.563/.557 (14.3/14.1)	.735/.711 (18.7/18.1)	.570 (14.5)	1.078 (27.4)
10	.750 (19.1)	.673/.667 (17.1/16.9)	.735/.711 (18.7/18.1)	.680 (17.3)	1.078 (27.4)
12	.844 (21.4)	.782/.776 (20.0/19.7)	.735/.711 (18.7/18.1)	.789 (20.0)	1.078 (27.4)
14	.969 (24.6)	.907/.901 (23.0/22.9)	.735/.711 (18.7/18.1)	.914 (23.2)	1.078 (27.4)
16	1.094 (27.8)	1.032/1.026 (26.2/26.1)	.735/.711 (18.7/18.1)	1.039 (26.4)	1.078 (27.4)
18	1.218 (30.9)	1.157/1.151 (29.4/29.2)	.735/.711 (18.7/18.1)	1.164 (29.6)	1.078 (27.4)
20	1.312 (33.3)	1.251/1.245 (31.8/31.6)	.823/.799 (20.9/20.3)	1.258 (32.0)	1.140 (29.0)
22	1.438 (36.5)	1.376/1.371 (35.0/34.8)	.823/.799 (20.9/20.3)	1.383 (35.1)	1.140 (29.0)
24	1.564 (39.7)	1.501/1.495 (38.1/38.0)	.823/.799 (20.9/20.3)	1.508 (38.3)	1.140 (29.0)

**APPLICATION NOTES**

- To be identified with manufacturer's name, part number and date code, space permitting.
- Material/Finish:  
Shell: Z1 - Stainless steel/passivate.  
ZL - Stainless steel/nickel plate.  
FT - Stainless steel/tin plated.  
Titanium and Inconel® available. Consult factory.  
Contacts - 52 Nickel alloy/gold plate.  
Bayonets - Stainless steel/passivate.  
Seals - Silicone elastomer/N.A.  
Insulation - Glass/N.A.  
Rear insulator - Rigid dielectric/N.A.
- Glenair 230-020 will mate with any QPL MIL-DTL-26482 Series II bayonet coupling plug of same size and insert polarization.
- Performance:  
Hermeticity - <1 x 10<sup>-7</sup> cc/sec @ 1 atm differential.  
Dielectric withstanding voltage - Consult factory or MIL-STD-1669.  
Insulation resistance - 5000 megohms min @500VDC.
- See Table II for available insert arrangement option.
- Connectors are supplied with applicable crimp socket contacts per MIL-C-39029/22-\*\*\* and MS3160-\*\*\* insert and removal tool.
- Metric Dimensions (mm) are indicated in parentheses.



**230-021**  
**MIL-DTL-26482 Series II Type Hermetic**  
**Bayonet Coupling Box Mount Receptacle**  
**with Crimp Removable Contacts • MS3477 Type**

**D**

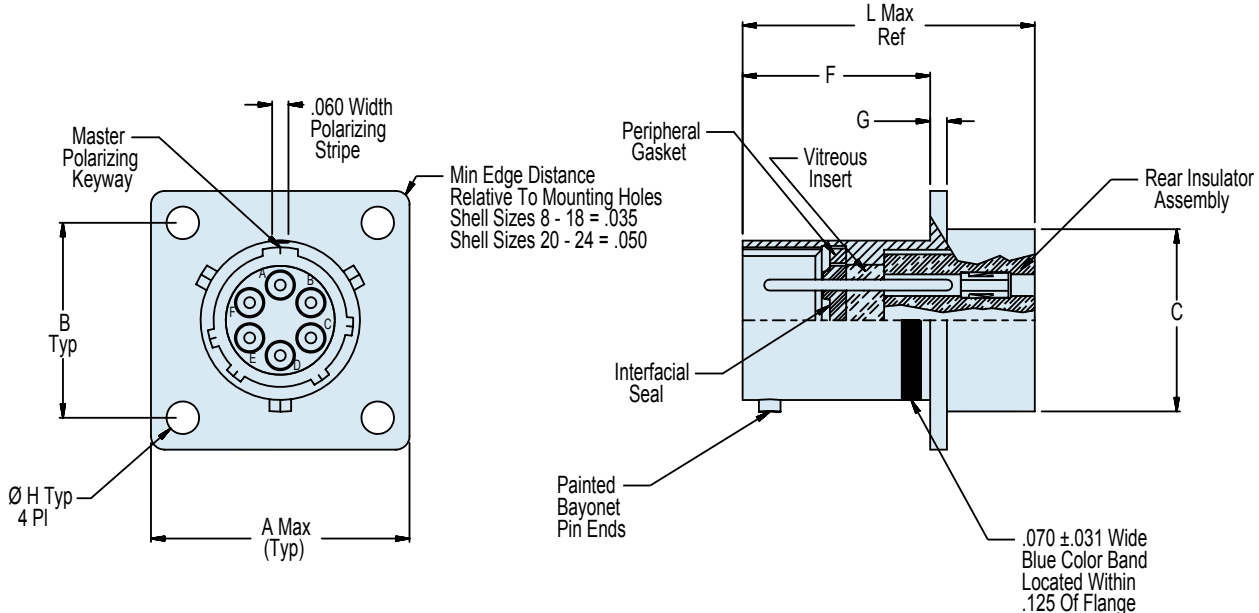
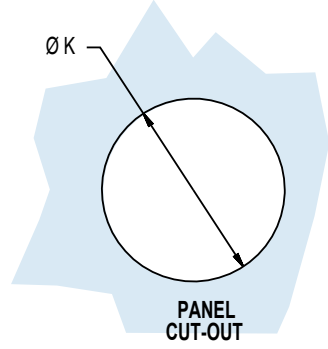
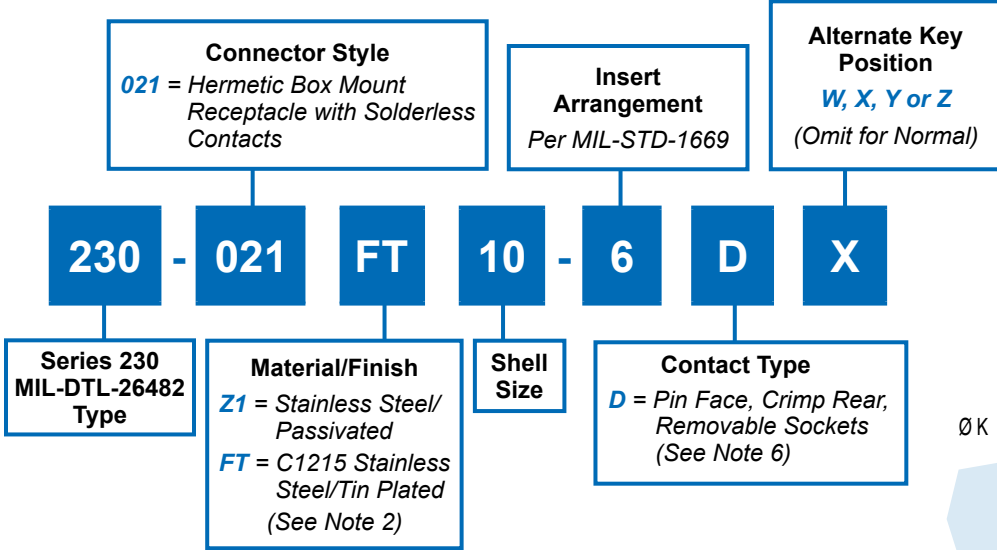

**230-021**  
**MIL-DTL-26482 Series II Type Hermetic**  
**Bayonet Coupling Box Mount Receptacle**  
**with Crimp Removable Contacts • MS3477 Type**



MIL-DTL-26482  
Type

**D**

HERMETIC LEAK RATE MOD CODES	
Designator	Required Leak Rate
-585A	1 x 10 <sup>-10</sup> cc Helium per second
-585B	1 x 10 <sup>-9</sup> cc Helium per second
-585C	1 x 10 <sup>-8</sup> cc Helium per second

TABLE I: CONNECTOR AND CUT-OUT DIMENSIONS								
Shell Size	A	B	C Dia Mounting Locator	F	G	H	K Dia Panel Cut-Out	L
8	.828 (21.0)	.594 (15.1)	.563/.557 (14.3/14.1)	.704/.680 (17.9/17.3)	.078/.046 (2.0/1.2)	.120 (3.0)	.570 (14.5)	1.078 (27.4)
10	.954 (24.2)	.719 (18.3)	.673/.667 (17.1/16.9)	.704/.680 (17.9/17.3)	.078/.046 (2.0/1.2)	.120 (3.0)	.680 (17.3)	1.078 (27.4)
12	1.047 (26.6)	.812 (20.6)	.782/.776 (20.0/19.7)	.704/.680 (17.9/17.3)	.078/.046 (2.0/1.2)	.120 (3.0)	.789 (20.0)	1.078 (27.4)
14	1.141 (29.0)	.906 (23.0)	.907/.901 (23.0/22.9)	.704/.680 (17.9/17.3)	.078/.046 (2.0/1.2)	.120 (3.0)	.914 (23.2)	1.078 (27.4)
16	1.234 (31.3)	.969 (24.6)	1.032/1.026 (26.2/26.1)	.704/.680 (17.9/17.3)	.078/.046 (2.0/1.2)	.120 (3.0)	1.039 (26.4)	1.078 (27.4)
18	1.328 (33.7)	1.062 (27.0)	1.157/1.151 (29.4/29.2)	.704/.680 (17.9/17.3)	.078/.046 (2.0/1.2)	.120 (3.0)	1.164 (29.6)	1.078 (27.4)
20	1.453 (36.9)	1.156 (29.4)	1.251/1.245 (31.8/31.6)	.756/.739 (18.9/18.8)	.110/.078 (2.8/2.0)	.120 (3.0)	1.258 (32.0)	1.140 (29.0)
22	1.578 (40.1)	1.250 (31.8)	1.376/1.371 (35.0/34.8)	.756/.739 (18.9/18.8)	.110/.078 (2.8/2.0)	.120 (3.0)	1.383 (35.1)	1.140 (29.0)
24	1.703 (43.3)	1.375 (34.9)	1.501/1.495 (38.1/38.0)	.756/.739 (18.9/18.8)	.110/.078 (2.8/2.0)	.147 (3.7)	1.508 (38.3)	1.140 (29.0)

APPLICATION NOTES	
1. To be identified with manufacturer's name, part number and date code, space permitting.	Series II bayonet coupling plug of same size and insert polarization.
2. Material/Finish: Shell: Z1 - 304L stainless steel/passivate. FT - C1215 stainless steel/tin plated. Titanium and Inconel® available. Consult factory. Contacts - 52 Nickel alloy/gold plate. Bayonets - Stainless steel/passivate. Seals - Silicone elastomer/N.A. Insulation - Glass/N.A. Rear insulator - Rigid dielectric/N.A.	4. Performance: Hermeticity - <1 x 10 <sup>-7</sup> cc/sec @ 1 atm differential. Dielectric withstanding voltage - Consult factory or MIL-STD-1669. Insulation resistance - 5000 megohms min @500VDC.
3. Glenair 230-021 will mate with any QPL MIL-DTL-26482	5. See Table II for available insert arrangement option.
	6. Connectors are supplied with applicable crimp socket contacts per MIL-C-39029/22-** and MS3160-** insert and removal tool.
	7. Metric Dimensions (mm) are indicated in parentheses.



**230-022**  
**MIL-DTL-26482 Series II Type Hermetic**  
**Bayonet Coupling Jam Nut Mount Receptacle**  
**with Crimp Removable Contacts • MS3479 Type**

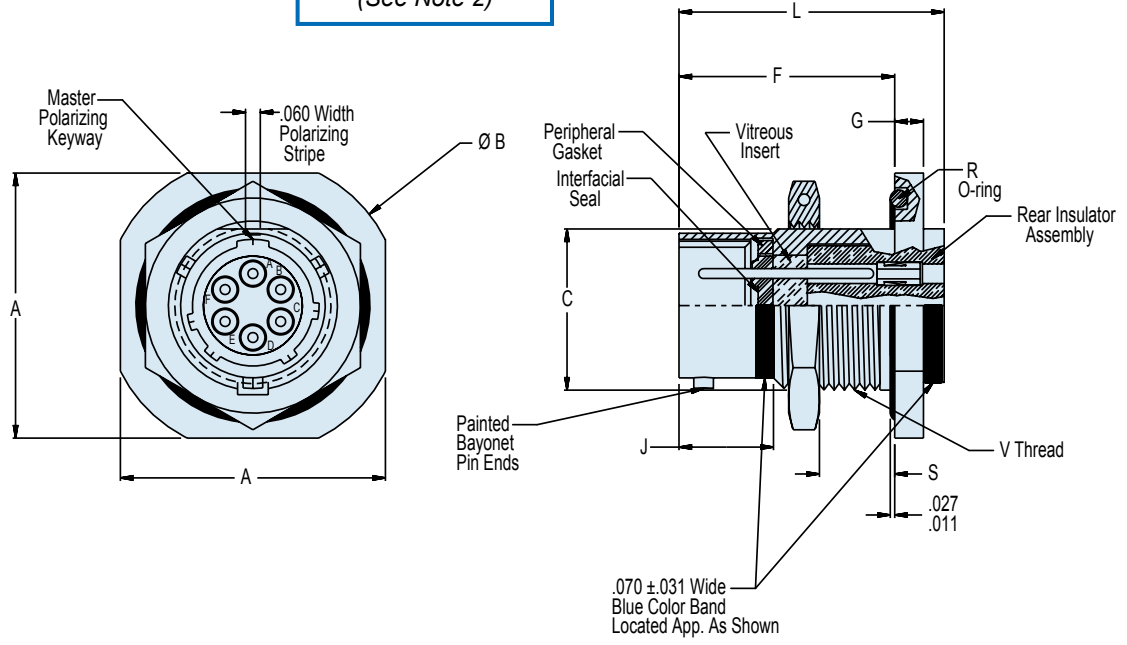
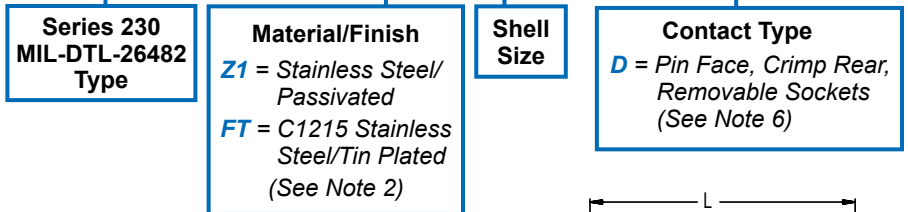

**APPLICATION NOTES**

- |  |   |
|--|---|
| <ol style="list-style-type: none"> <li>To be identified with manufacturer's name, part number and date code, space permitting.</li> <li>Material/Finish:<br/>                     Shell: Z1 - 304L stainless steel/passivate.<br/>                     FT - C1215 stainless steel/tin plated.<br/>                     Titanium and Inconel® available. Consult factory.<br/>                     Contacts - 52 Nickel alloy/gold plate.<br/>                     Bayonets - Stainless steel/passivate.<br/>                     Seals - Silicone elastomer/N.A.<br/>                     Insulation - Glass/N.A.<br/>                     Rear insulator - Rigid dielectric/N.A.</li> <li>Glenair 230-022 will mate with any QPL MIL-DTL-26482</li> </ol> | <ol style="list-style-type: none"> <li>Series II bayonet coupling plug of same size and insert polarization.</li> <li>Performance:<br/>                     Hermeticity - &lt;math&gt;1 \times 10^{-7}&lt;/math&gt; cc/sec @ 1 atm differential.<br/>                     Dielectric withstanding voltage - Consult factory or MIL-STD-1669.<br/>                     Insulation resistance - 5000 megohms min @500VDC.</li> <li>See Table II for available insert arrangement option.</li> <li>Connectors are supplied with applicable crimp socket contacts per MIL-C-39029/22-** and MS3160-** insert and removal tool.</li> <li>Metric Dimensions (mm) are indicated in parentheses.</li> </ol> |
|--|---|

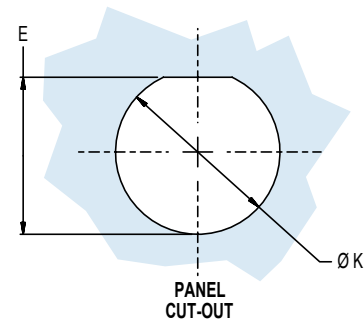

**TABLE I: CONNECTOR AND CUT-OUT DIMENSIONS (Continued Below)**

Shell Size	A Length + .000 - .031 (+0 -0.8)	B Dia + .000 - .031 (+0 -0.8) Across Flange Corner	C + .000 - .010 (+0 -0.3) Mounting Flat	E Panel Flat Location	F Mounting Flange Location	G Mounting Flange Thickness	J To Thread Chamfer ± .010 (0.3)	K + .010 - .005 (+0.3 -0.1) Panel Mounting Hole
8	.954 (24.2)	1.078 (27.4)	.530 (13.5)	.536 (13.6)	.887/.867 (22.5/22.0)	.113/.097 (2.9/2.5)	.368 (9.3)	.572 (14.5)
10	1.078 (27.4)	1.203 (30.6)	.655 (16.6)	.661 (16.8)	.887/.867 (22.5/22.0)	.113/.097 (2.9/2.5)	.368 (9.3)	.697 (17.7)
12	1.266 (32.2)	1.391 (35.3)	.818 (20.8)	.824 (20.9)	.887/.867 (22.5/22.0)	.113/.097 (2.9/2.5)	.368 (9.3)	.885 (22.5)
14	1.391 (35.3)	1.516 (38.5)	.942 (23.9)	.948 (24.1)	.887/.867 (22.5/22.0)	.113/.097 (2.9/2.5)	.368 (9.3)	1.010 (25.7)
16	1.516 (38.5)	1.641 (41.7)	1.062 (27.0)	1.072 (27.2)	.887/.867 (22.5/22.0)	.113/.097 (2.9/2.5)	.368 (9.3)	1.135 (28.8)
18	1.641 (41.7)	1.766 (44.9)	1.191 (30.3)	1.197 (30.4)	.887/.867 (22.5/22.0)	.113/.097 (2.9/2.5)	.368 (9.3)	1.260 (32.0)
20	1.828 (46.4)	1.954 (49.6)	1.316 (33.4)	1.322 (33.6)	.916/.896 (23.3/22.8)	.148/.128 (3.8/3.3)	.368 (9.3)	1.385 (35.2)
22	1.954 (49.6)	2.078 (52.8)	1.441 (36.6)	1.447 (36.8)	.916/.896 (23.3/22.8)	.148/.128 (3.8/3.3)	.368 (9.3)	1.510 (38.4)
24	2.078 (52.8)	2.203 (56.0)	1.566 (39.8)	1.572 (39.9)	.916/.896 (23.3/22.8)	.148/.128 (3.8/3.3)	.395 (10.0)	1.635 (41.5)

**TABLE I (Continued): CONNECTOR AND CUT-OUT DIMENSIONS**

Shell Size	L Overall Length	N UNEF-2A Mounting Thread	P	R O-Ring Seal MS29513-	S Panel Thickness		Max. Weight (Lbs)
					Min	Max	
8	1.078 (27.4)	.5625-24	.134/.074 (3.4/1.9)	16	.062 (1.6)	.187 (4.7)	TBD
10	1.078 (27.4)	.6875-24	.134/.074 (3.4/1.9)	18	.062 (1.6)	.187 (4.7)	TBD
12	1.078 (27.4)	.875-20	.134/.074 (3.4/1.9)	21	.062 (1.6)	.187 (4.7)	TBD
14	1.078 (27.4)	1.000-20	.134/.074 (3.4/1.9)	23	.062 (1.6)	.187 (4.7)	TBD
16	1.078 (27.4)	1.125-18	.134/.074 (3.4/1.9)	25	.062 (1.6)	.187 (4.7)	TBD
18	1.078 (27.4)	1.250-18	.134/.074 (3.4/1.9)	27	.062 (1.6)	.187 (4.7)	TBD
20	1.140 (29.0)	1.375-18	.099/.039 (2.5/1.0)	29	.062 (1.6)	.250 (6.4)	TBD
22	1.140 (29.0)	1.500-18	.099/.039 (2.5/1.0)	30	.062 (1.6)	.250 (6.4)	TBD
24	1.140 (29.0)	1.625-18	.099/.039 (2.5/0.10)	31	.062 (1.6)	.250 (6.4)	TBD

**HERMETIC LEAK RATE MOD CODES**

Designator	Required Leak Rate
-585A	1 x 10 <sup>-10</sup> cc Helium per second
-585B	1 x 10 <sup>-9</sup> cc Helium per second
-585C	1 x 10 <sup>-8</sup> cc Helium per second



**230-034**  
**MIL-DTL-26482 Series II Type Hermetic**  
**Bayonet Coupling Jam-Nut Mount Receptacle**  
**MS3449 Type**

**Connector Style**  
*034 = Single Hole Jam-Nut Mount Receptacle*

**Insert Arrangement**  
*Per MIL-STD-1669*

**Alternate Key Position**  
*W, X, Y or Z*  
*(Omit for Normal)*

**230**

**- 034**

**FT**

**10**

**- 6**

**P**

**X**

**Series 230**  
**MIL-DTL-26482**  
**Type**

**Material/Finish**  
*Z1 = Stainless Steel/Passivated*  
*FT = C1215 Stainless Steel/Tin Plated*  
*(See Note 2)*

**Shell Size**

**Contact Type**  
*P = Solder Cup, Pin Face*  
*S = Solder Cup, Socket Face*

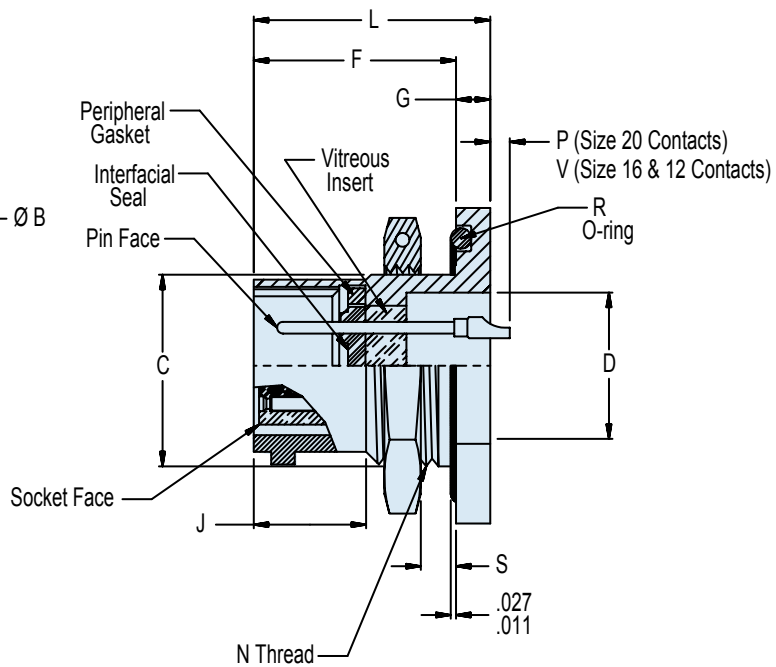
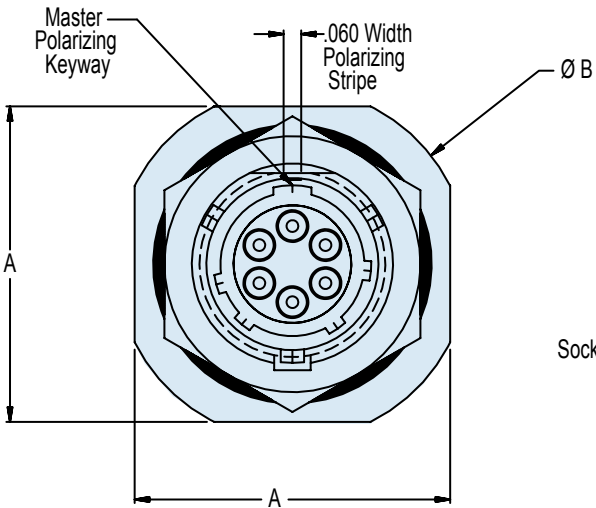
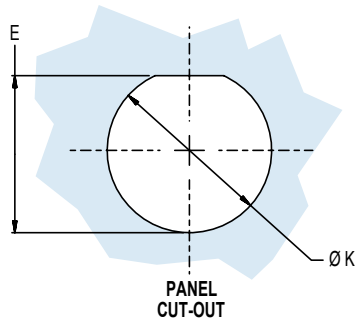

**APPLICATION NOTES**

- To be identified with manufacturer's name, part number and date code, space permitting.
- Material/Finish:  
Shell: Z1 - 304L stainless steel/passivate.  
FT - C1215 stainless steel/tin plated.  
Titanium and Inconel® available. Consult factory.  
Contacts - 52 Nickel alloy/gold plate.  
Bayonets - Stainless steel/passivate.  
Seals - Silicone elastomer/N.A.  
Insulation - Glass/N.A.  
Socket insulator - Rigid dielectric/N.A.
- Glenair 230-034 will mate with any QPL MIL-DTL-26482 Series II bayonet coupling plug of same size and insert polarization.
- Performance:  
Hermeticity -  $<1 \times 10^{-7}$  cc/sec @ 1 atm differential.  
Dielectric withstanding voltage - Consult factory or MIL-STD-1669.  
Insulation resistance - 5000 megohms min @500VDC.
- Consult factory or MIL-STD-1669 for arrangement and insert position options.
- Metric Dimensions (mm) are indicated in parentheses.

230-034

MIL-DTL-26482 Series II Type Hermetic  
Bayonet Coupling Jam-Nut Mount Receptacle  
MS3449 Type



MIL-DTL-26482  
Type

TABLE I: CONNECTOR AND CUT-OUT DIMENSIONS (Continued Below)

Shell Size	A Length + .000 - .031 (+0 -0.8)	B Dia + .000 - .031 (+0 -0.8) Across Flange Corner	C + .000 - .010 (+0 -0.3) Mounting Flat	D Dia Min	E Panel Flat Location	F Mounting Flange Location	G Mounting Flange Thickness	J To Thread Chamfer ± .010 (0.3)	K + .010 - .005 (+0.3 -0.1) Panel Mounting Hole
8	.954 (24.2)	1.078 (27.4)	.530 (13.5)	.403 (10.2)	.536 (13.6)	.707/.691 (18.0/17.6)	.113/.097 (2.9/2.5)	.368 (9.3)	.572 (14.5)
10	1.078 (27.4)	1.203 (30.6)	.655 (16.6)	.515 (13.1)	.661 (16.8)	.707/.691 (18.0/17.6)	.113/.097 (2.9/2.5)	.368 (9.3)	.697 (17.7)
12	1.266 (32.2)	1.391 (35.3)	.818 (20.8)	.630 (16.0)	.824 (20.9)	.707/.691 (18.0/17.6)	.113/.097 (2.9/2.5)	.368 (9.3)	.885 (22.5)
14	1.391 (35.3)	1.516 (38.5)	.942 (23.9)	.755 (19.2)	.948 (24.1)	.707/.691 (18.0/17.6)	.113/.097 (2.9/2.5)	.368 (9.3)	1.010 (25.7)
16	1.516 (38.5)	1.641 (41.7)	1.062 (27.0)	.880 (22.4)	1.072 (27.2)	.707/.691 (18.0/17.6)	.113/.097 (2.9/2.5)	.368 (9.3)	1.135 (28.8)
18	1.641 (41.7)	1.766 (44.9)	1.191 (30.3)	.980 (24.9)	1.197 (30.4)	.707/.691 (18.0/17.6)	.113/.097 (2.9/2.5)	.368 (9.3)	1.260 (32.0)
20	1.828 (46.4)	1.954 (49.6)	1.316 (33.4)	1.105 (28.1)	1.322 (33.6)	.772/.754 (19.6/19.2)	.148/.128 (3.8/3.3)	.368 (9.3)	1.385 (35.2)
22	1.954 (49.6)	2.078 (52.8)	1.441 (36.6)	1.230 (31.2)	1.447 (36.8)	.772/.754 (19.6/19.2)	.148/.128 (3.8/3.3)	.368 (9.3)	1.510 (38.4)
24	2.078 (52.8)	2.203 (56.0)	1.566 (39.8)	1.385 (35.2)	1.572 (39.9)	.803/.785 (20.4/19.9)	.148/.128 (3.8/3.3)	.395 (10.0)	1.635 (41.5)

D

TABLE I (Continued): CONNECTOR AND CUT-OUT DIMENSIONS

Shell Size	L Overall Length	N UNEF-2A Mounting Thread	P	R O-Ring Seal MS29513-	S Panel Thickness		V	Max. Weight (Lbs)
					Min	Max		
8	.820 (20.8)	.5625-24	.134/.074 (3.4/1.9)	16	.062 (1.6)	.187 (4.7)	.204/.144 (5.2/3.7)	.0430
10	.820 (20.8)	.6875-24	.134/.074 (3.4/1.9)	18	.062 (1.6)	.187 (4.7)	.204/.144 (5.2/3.7)	.0610
12	.820 (20.8)	.875-20	.134/.074 (3.4/1.9)	21	.062 (1.6)	.187 (4.7)	.204/.144 (5.2/3.7)	.0880
14	.820 (20.8)	1.000-20	.134/.074 (3.4/1.9)	23	.062 (1.6)	.187 (4.7)	.204/.144 (5.2/3.7)	.1100
16	.820 (20.8)	1.125-18	.134/.074 (3.4/1.9)	25	.062 (1.6)	.187 (4.7)	.204/.144 (5.2/3.7)	.1310
18	.820 (20.8)	1.250-18	.134/.074 (3.4/1.9)	27	.062 (1.6)	.187 (4.7)	.204/.144 (5.2/3.7)	.1720
20	.920 (23.4)	1.375-18	.099/.039 (2.5/1.0)	29	.062 (1.6)	.250 (6.4)	.169/.109 (4.3/2.8)	.2110
22	.920 (23.4)	1.500-18	.099/.039 (2.5/1.0)	30	.062 (1.6)	.250 (6.4)	.169/.109 (4.3/2.8)	.2420
24	.951 (24.2)	1.625-18	.099/.039 (2.5/0.1)	31	.062 (1.6)	.250 (6.4)	.169/.109 (4.3/2.8)	.2930

HERMETIC LEAK RATE MOD CODES

Designator	Required Leak Rate
-585A	1 x 10 <sup>-10</sup> cc Helium per second
-585B	1 x 10 <sup>-9</sup> cc Helium per second
-585C	1 x 10 <sup>-8</sup> cc Helium per second



**237-051**  
**MIL-DTL-26482 Series II, MS3440 Type Hermetic**  
**Special Narrow Square Flange Mount Receptacle**  
**with Bayonet Coupling and Solder Cup Termination**

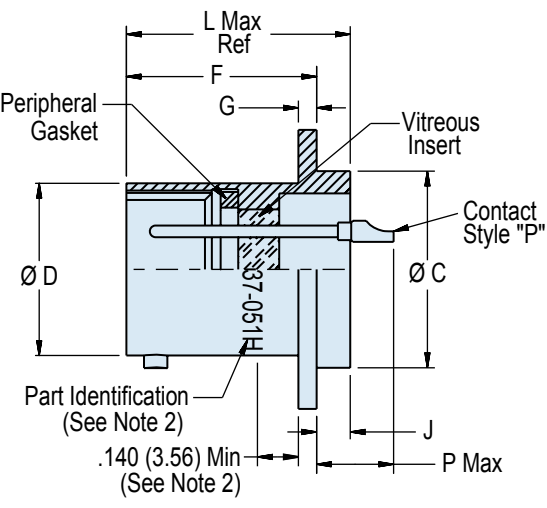
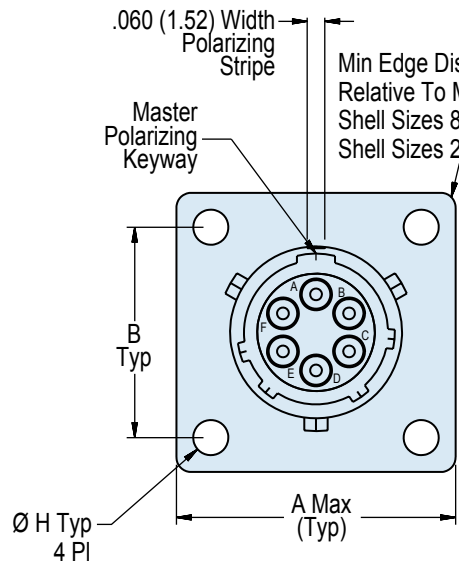
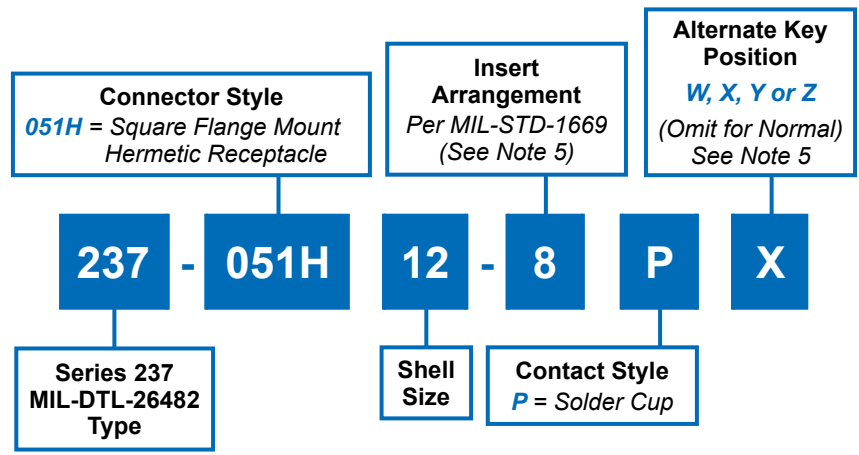

**APPLICATION NOTES**

- Material/Finish:  
 Shell - C1215 CRS/Tin plated.  
 Titanium and Inconel® available. Consult factory.  
 Contacts - 52 nickel alloy/Tin plated.  
 Bayonets - Stainless Steel/passivated.  
 Seals - Silicone elastomer/N.A.  
 Insulator - Glass, NOIBN/N.A.
- To be identified with manufacturer's name, part number and date code, space permitting.
- Hermeticity -  $<1 \times 10^{-7}$  cc/sec @ 1 atm differential.  
 Dielectric withstanding voltage - Consult factory or MIL-STD-1669.  
 Insulation resistance - 5000 megohms min @500VDC.
- Glenair 237-051 will mate with any QPL MIL-DTL-26482 Series II bayonet coupling plug of same size and insert polarization.
- Consult factory and/or MIL-STD-1669 for arrangement and insert position options.
- Metric Dimensions (mm) are indicated in parentheses.

237-051

**MIL-DTL-26482 Series II, MS3440 Type Hermetic  
Special Narrow Square Flange Mount Receptacle  
with Bayonet Coupling and Solder Cup Termination**



MIL-DTL-26482  
Type

**D**

**TABLE I: CONNECTOR AND CUT-OUT DIMENSIONS  
(Continued Below)**

Shell Size	A	B	C Dia Mounting Locator	D Dia	F	G
8	.828 (21.03)	.594 (15.09)	.563/.557 (14.30/14.15)	.474/.468 (12.04/11.89)	.519/.479 (13.18/12.17)	.073/.052 (1.85/1.32)
10	.954 (24.23)	.719 (18.26)	.673/.667 (17.09/16.94)	.591/.585 (15.01/14.86)		
12	1.047 (26.59)	.812 (20.62)	.782/.776 (19.86/19.71)	.751/.745 (19.08/18.92)		
14	1.141 (28.98)	.906 (23.01)	.907/.901 (23.03/22.89)	.876/.870 (22.25/22.10)		
16	1.234 (31.34)	.969 (24.61)	1.032/1.026 (26.21/26.06)	1.001/.995 (25.43/25.27)		
18	1.328 (33.73)	1.062 (26.97)	1.157/1.151 (29.39/29.24)	1.126/1.120 (28.60/28.45)		
20	1.453 (36.91)	1.156 (29.36)	1.251/1.245 (31.78/31.62)	1.251/1.245 (31.78/31.62)	.581/.541 (14.76/13.74)	
22	1.578 (40.08)	1.250 (31.75)	1.376/1.371 (34.95/34.82)	1.376/1.371 (34.95/34.82)		
24	1.703 (43.26)	1.375 (34.93)	1.501/1.495 (38.13/37.97)	1.501/1.495 (38.13/37.97)		

**TABLE I: CONNECTOR AND CUT-OUT DIMENSIONS  
(Continued from Above)**

Shell Size	H	J	L	P Max	Panel Cut-Out Dia	Max Weight Lbs. (Kg)
8	.120 (3.05)	.125/.105 (3.18/2.67)	.801 (20.35)	.344 (8.74)	.570 (14.48)	.038 (.017)
10					.680 (17.27)	.044 (.020)
12					.789 (20.04)	.052 (.024)
14					.914 (23.22)	.070 (.032)
16					1.039 (26.39)	.085 (.039)
18					1.164 (29.57)	.098 (.045)
20	.147 (3.73)	.093/.073 (2.36/1.85)	.863 (21.92)	.377 (9.58)	1.258 (31.95)	.110 (.050)
22		.125/.105 (3.18/2.67)	.895 (22.73)		1.383 (35.13)	.150 (.068)
24					1.508 (38.30)	.280 (.127)

**HERMETIC LEAK RATE MOD CODES**

Designator	Required Leak Rate
-585A	1 x 10 <sup>-10</sup> cc Helium per second
-585B	1 x 10 <sup>-9</sup> cc Helium per second
-585C	1 x 10 <sup>-8</sup> cc Helium per second



**237-133**  
**MIL-DTL-26482 Series I, MS3112 Type Hermetic**  
**Square Flange Mount Receptacle**  
**with Bayonet Coupling and Solder Cup Termination**

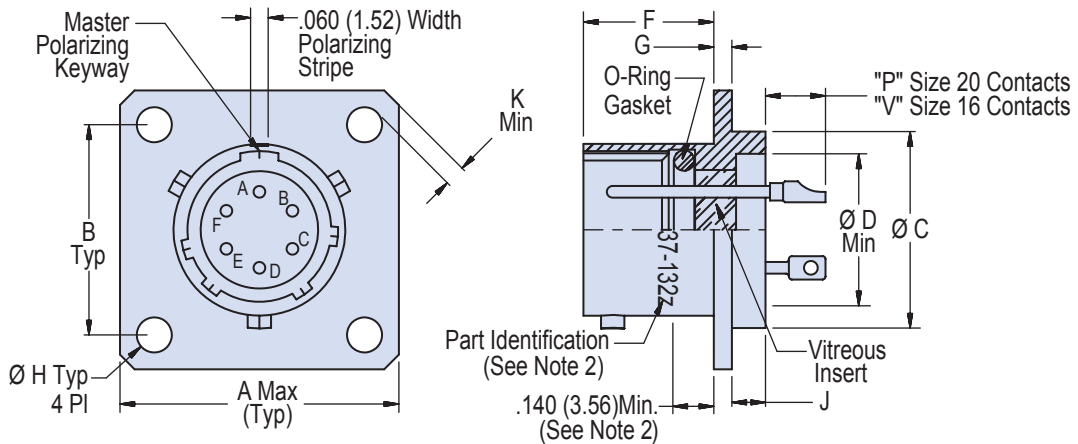
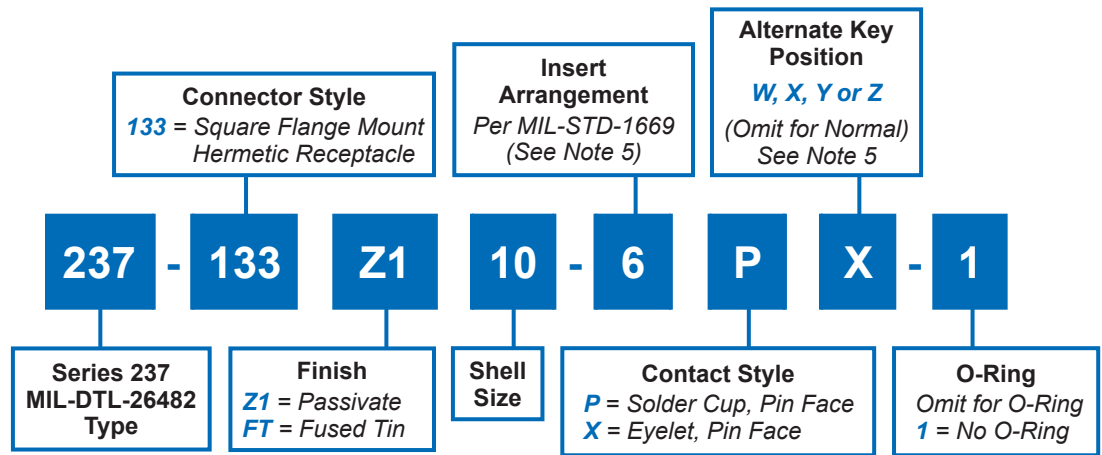

**APPLICATION NOTES**

- Material/Finish:  
 Z1 Shell - 304 CRES/passivated.  
 FT Shell - C1215 CRS/Tin plated.  
 Titanium and Inconel® available. Consult factory.  
 Contacts - 52 nickel alloy/Tin plate.  
 Bayonets - Stainless Steel/passivated.  
 O-Ring Seal - Silicone elastomer/N.A.  
 Insulator - Glass/N.A.
- To be identified with manufacturer's name, part number and date code, space permitting.
- Hermeticity -  $<1 \times 10^{-7}$  cc/sec @ 1 atm differential.  
 Dielectric withstanding voltage - Consult factory or MIL-STD-1669.  
 Insulation resistance - 5000 megohms min @500VDC.
- Glenair 237-133 will mate with any QPL MIL-DTL-26482 Series I bayonet coupling plug of same size and insert polarization with opposite contact gender.
- Consult factory and/or MIL-STD-1669 for arrangement and insert position options.
- Metric Dimensions (mm) are indicated in parentheses.

**237-133**  
**MIL-DTL-26482 Series I, MS3112 Type Hermetic**  
**Square Flange Mount Receptacle**  
**with Bayonet Coupling and Solder Cup Termination**



MIL-DTL-26482  
Type

**D**

**TABLE I: CONNECTOR AND CUT-OUT DIMENSIONS**  
**(Continued Below)**

Shell Size	A	B	C Dia Mounting Locator	D Dia Min	F	G
8	.828 (21.03)	.594 (15.09)	.563/.557 (14.30/14.15)	.403 (10.24)	.462/.431 (11.73/10.95)	.078/.046 (1.98/1.17)
10	.954 (24.23)	.719 (18.26)	.673/.667 (17.09/16.94)	.515 (13.08)		
12	1.047 (26.59)	.812 (20.62)	.782/.776 (19.86/19.71)	.630 (16.00)		
14	1.141 (28.98)	.906 (23.01)	.907/.901 (23.03/22.89)	.755 (19.18)		
16	1.234 (31.34)	.969 (24.61)	1.032/1.026 (26.21/26.06)	.880 (22.35)		
18	1.328 (33.73)	1.062 (26.97)	1.157/1.151 (29.39/29.24)	.980 (24.89)		
20	1.453 (36.91)	1.156 (29.36)	1.251/1.245 (31.78/31.62)	1.105 (28.07)	.556/.525 (14.12/13.34)	.110/.078 (2.79/1.98)
22	1.578 (40.08)	1.250 (31.75)	1.376/1.371 (34.95/34.82)	1.230 (31.24)		
24	1.703 (43.26)	1.375 (34.93)	1.501/1.495 (38.13/37.97)	1.385 (35.18)		

**TABLE I: CONNECTOR AND CUT-OUT DIMENSIONS**  
**(Continued from Above)**

Shell Size	H	J	K	P	V	Panel Cut-Out Dia
8	.120 (3.05)	.063/.037 (1.60/0.94)	.035 (0.89)	.178/.118 (4.52/3.00)	.248/.118 (6.30/3.00)	.570 (14.48)
10						.680 (3.67)
12						.789 (20.04)
14						.914 (23.22)
16						1.039 (26.39)
18						1.164 (29.57)
20		1.258 (31.95)				
22		.095/.063 (2.41/1.60)	.050 (1.27)	.146/.086 (37.08/2.18)	2.16/.156 (54.86/3.96)	1.383 (35.13)
24	.147 (3.73)	1.508 (38.30)				

**HERMETIC LEAK RATE MOD CODES**

Designator	Required Leak Rate
-585A	1 x 10 <sup>-10</sup> cc Helium per second
-585B	1 x 10 <sup>-9</sup> cc Helium per second
-585C	1 x 10 <sup>-8</sup> cc Helium per second





**237-240**  
**MIL-DTL-26482 Series I Type Hermetic**  
**Special Square Flange Mount Receptacle**  
**with Bayonet Coupling and Solder Cup Termination**

**D**

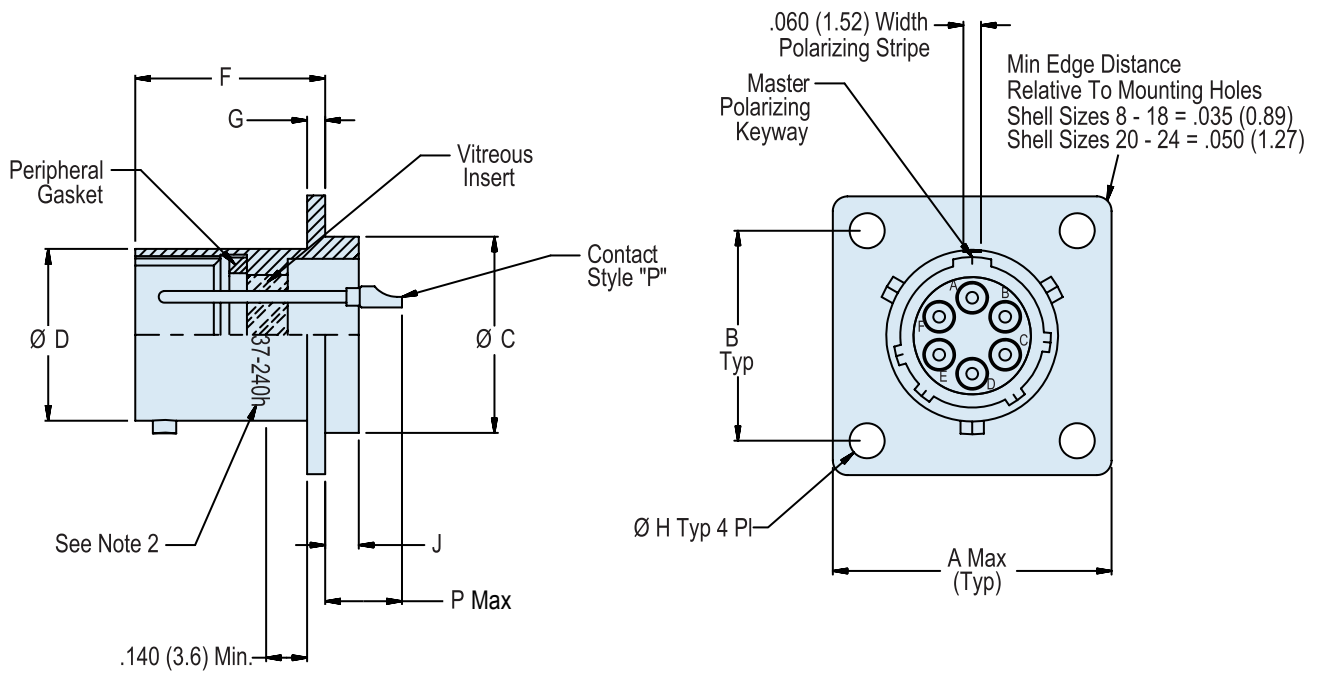
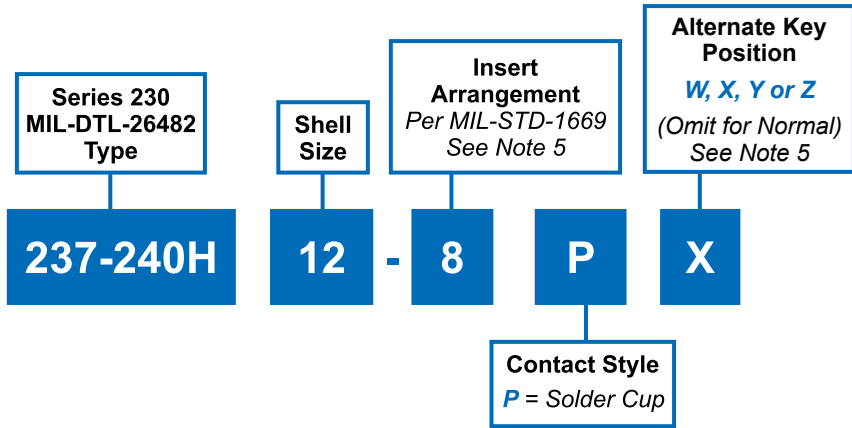

**237-240**  
**MIL-DTL-26482 Series I Type Hermetic**  
**Special Square Flange Mount Receptacle**  
**with Bayonet Coupling and Solder Cup Termination**



MIL-DTL-26482  
Type

**D**

**TABLE I: CONNECTOR AND CUT-OUT DIMENSIONS**

Shell Size	A ±.016 (0.41)	B	C Dia	D Dia	F +.025 -.015 (+0.64 -0.38)	G +.011 -.010 (+0.28 -0.25)	H ±.005 (0.13)	J ±.015 (0.38)	P Max	Panel Cut-Out Dia	Max Weight (Lbs)
8	.812 (20.62)	.594 (15.09)	.563/.557 (14.30/14.15)	.474/.468 (12.04/11.89)	.494 (12.55)	.062 (1.57)	.120 (3.05)	.047 (1.19)	.344 (8.74)	.570 (14.48)	.038
10	.938 (23.83)	.719 (18.3)	.673/.667 (17.09/16.94)	.591/.585 (15.01/14.86)	.494 (12.55)	.062 (1.57)	.120 (3.05)	.047 (1.19)	.344 (8.74)	.680 (17.27)	.044
12	1.031 (26.19)	.812 (20.6)	.782/.776 (19.86/19.71)	.751/.745 (19.08/18.92)	.494 (12.55)	.062 (1.57)	.120 (3.05)	.047 (1.19)	.344 (8.74)	.789 (20.04)	.052
14	1.125 (28.58)	.906 (23.0)	.907/.901 (23.04/22.89)	.876/.870 (22.35/22.10)	.494 (12.55)	.062 (1.57)	.120 (3.05)	.047 (1.19)	.344 (8.74)	.914 (23.22)	.070
16	1.219 (30.96)	.969 (24.6)	1.032/1.026 (26.21/26.06)	1.001/.995 (25.43/25.27)	.494 (12.55)	.062 (1.57)	.120 (3.05)	.047 (1.19)	.344 (8.74)	1.039 (26.39)	.085
18	1.312 (33.32)	1.062 (27.0)	1.157/1.151 (29.39/29.24)	1.126/1.120 (28.60/28.45)	.494 (12.55)	.062 (1.57)	.120 (3.05)	.047 (1.19)	.344 (8.74)	1.164 (29.57)	.098
20	1.438 (36.53)	1.156 (29.4)	1.251/1.245 (31.78/31.62)	1.251/1.245 (31.78/31.62)	.556 (14.12)	.062 (1.57)	.120 (3.05)	.047 (1.19)	.344 (8.74)	1.258 (31.95)	.110
22	1.562 (39.67)	1.250 (31.8)	1.376/1.370 (34.95/34.80)	1.376/1.370 (34.95/34.80)	.556 (14.12)	.062 (1.57)	.120 (3.05)	.079 (2.01)	.377 (9.58)	1.383 (35.13)	.150
24	1.688 (42.88)	1.375 (34.9)	1.501/1.495 (38.13/37.93)	1.501/1.495 (38.13/37.97)	.588 (14.94)	.062 (1.57)	.147 (1.19)	.079 (2.01)	.377 (9.58)	1.508 (38.30)	.280

**APPLICATION NOTES**

- |  |   |
|--|---|
| <p>1. Material/Finish:<br/>                 Shell - C1215 CRS/pure tin plated, RoHS.<br/>                 Contacts - Nickel-iron alloy 52/pure tin plated, RoHS.<br/>                 Hermetic Insulator - Full glass/N.A.<br/>                 Bayonets - stainless steel/passivated.<br/>                 Seal - Silicone elastomer/N.A.<br/>                 Insulation - glass/N.A.</p> <p>2. Assembly to be identified with manufacturer's name, part number and date code, space permitting.</p> | <p>3. Performance requirements:<br/>                 Hermeticity - <math>&lt;1 \times 10^{-7}</math> sccHe/se @ 1 Atm. Diff.<br/>                 DWV - Consult factory or MIL-STD-1669.<br/>                 Insulation resistance - 5000 megohms min @ 500VDC.</p> <p>4. Glenair 237-240 will mate with any QPL MIL-DTL-26482 Series I Bayonet Coupling Plug (MS3116) of same size and insert polarization.</p> <p>5. Consult factory and/or MIL-STD-1669 for arrangement and insert position options.</p> <p>6. Metric Dimensions (mm) are indicated in parentheses.</p> |
|--|---|



**257-135**  
**MIL-DTL-26482 Series II Type Hermetic**  
**Bayonet Coupling Jam Nut Mount**  
**Pin-Pin Bulkhead Feedthrough Receptacle**

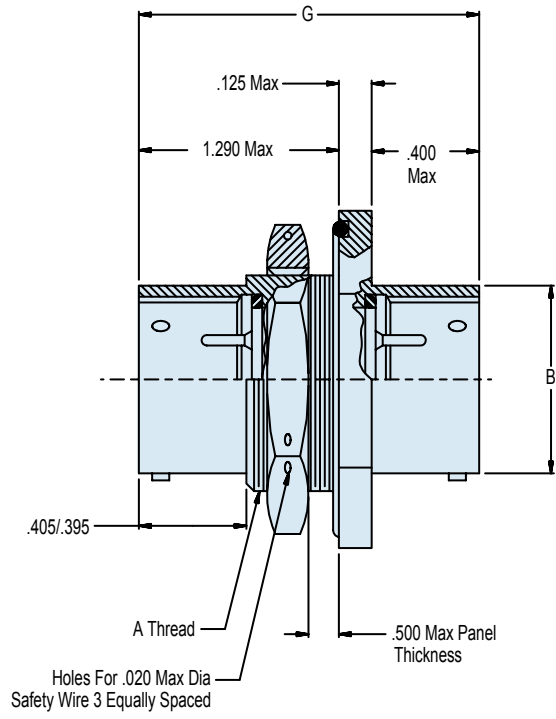
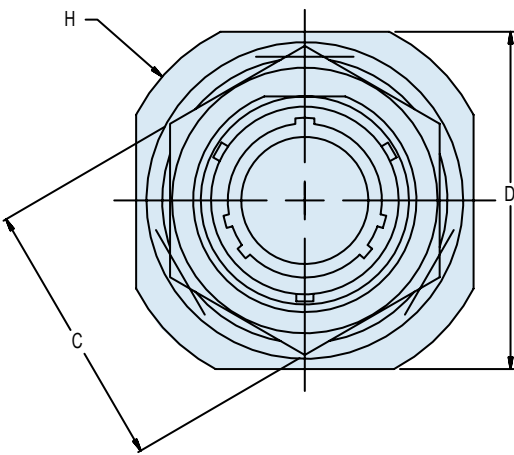
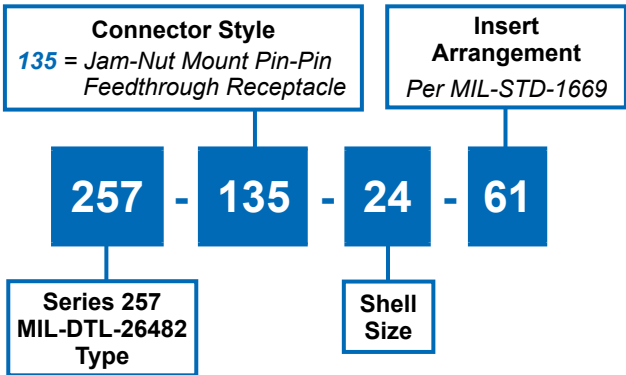

**APPLICATION NOTES**

- To be identified with manufacturer's name, part number and date code, space permitting.
- Electrical safety limits must be established by the user. Peak voltage, switching surge, transient, etc. should be used to determine the safety of the application.
- Metric Dimensions (mm) are indicated in parentheses.
- Material/Finish:**  
 Shell and jam-nut: Z1 - CRES/nickel plated.  
 Titanium and Inconel® available. Consult factory.  
 Contacts - Alloy 52/gold plate.  
 Bayonets - CRES/passivated.  
 Seals - Fluorosilicone/N.A.  
 Spacer - High grade rigid dielectric/N.A.  
 Insulator - Glass/N.A.

**257-135**  
**MIL-DTL-26482 Series II Type Hermetic**  
**Bayonet Coupling Jam Nut Mount**  
**Pin-Pin Bulkhead Feedthrough Receptacle**



MIL-DTL-26482  
Type

**D**

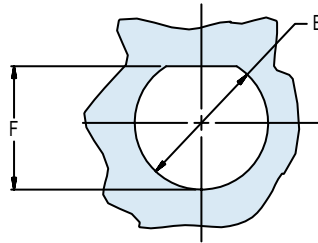

RECOMMENDED PANEL CUT-OUT

HERMETIC LEAK RATE MOD CODES	
Designator	Required Leak Rate
-585A	1 x 10 <sup>-10</sup> cc Helium per second
-585B	1 x 10 <sup>-9</sup> cc Helium per second
-585C	1 x 10 <sup>-8</sup> cc Helium per second

TABLE I: CONNECTOR AND CUT-OUT DIMENSIONS (Continued Below)								
Shell Size	A Thread Class 2A	B Dia Max	C Hex	D Flats	E Dia +.010 -.005 (+.03 -.01)	F Dia +.010 -.005 (+.03 -.01)	G Max	H Dia ± .016 (0.4)
8	9/16-24 UNEF	.474 (12.0)	.750 (19.1)	.938 (23.8)	.572 (14.5)	.540 (13.7)	2.125 (54.0)	1.062 (27.0)
10	11/16-24 UNEF	.591 (15.0)	.875 (22.2)	1.062 (27.0)	.697 (17.7)	.665 (16.9)	2.125 (54.0)	1.187 (30.1)
12	7/8-20 UNEF	.751 (19.1)	1.062 (27.0)	1.250 (31.8)	.895 (22.7)	.828 (21.0)	2.125 (54.0)	1.375 (34.9)
14	1-20 UNEF	.876 (22.3)	1.188 (30.2)	1.375 (34.9)	1.010 (25.7)	.952 (24.2)	2.125 (54.0)	1.500 (38.1)
16	1 1/8-18 UNEF	1.001 (25.4)	1.312 (33.3)	1.500 (38.1)	1.135 (28.8)	1.076 (27.3)	2.125 (54.0)	1.625 (41.3)
18	1 1/4-18 UNEF	1.126 (28.6)	1.438 (37.0)	1.625 (41.3)	1.260 (32.0)	1.201 (30.5)	2.125 (54.0)	1.750 (44.5)
20	1 3/8-18 UNEF	1.251 (31.8)	1.562 (39.7)	1.812 (46.0)	1.385 (35.2)	1.326 (33.7)	2.125 (54.0)	1.938 (49.2)
22	1 1/2-18 UNEF	1.376 (35.0)	1.688 (42.9)	1.938 (49.2)	1.510 (38.0)	1.451 (36.9)	2.125 (54.0)	2.062 (52.4)
24	1 5/8-18 UNEF	1.501 (38.1)	1.812 (46.0)	2.062 (52.4)	1.635 (41.5)	1.576 (40.0)	2.125 (54.0)	2.187 (55.5)



947-292

**MIL-DTL-26482 Series II Type Hermetic  
Bayonet Coupling Jam Nut Mount  
Pin-Socket Bulkhead Feedthrough Receptacle**

D

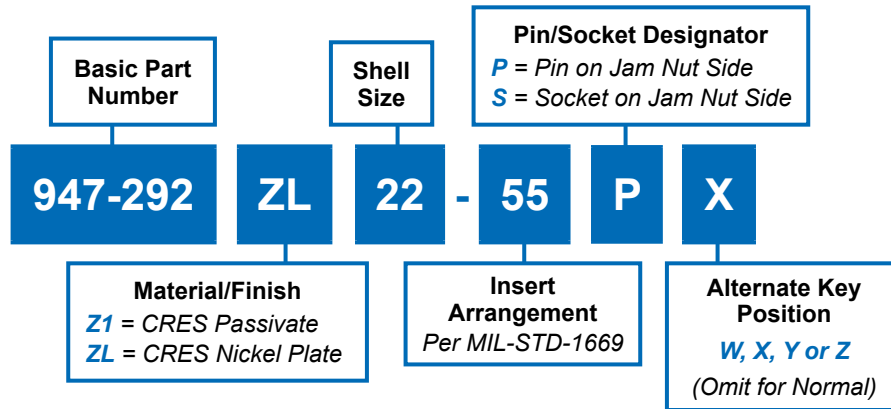

SEE MIL-STD-1669 FOR INSERT ARRANGEMENTS

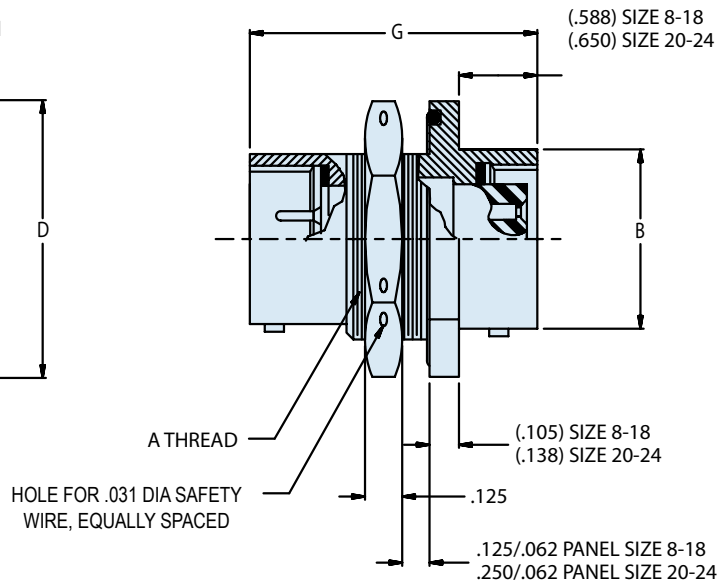
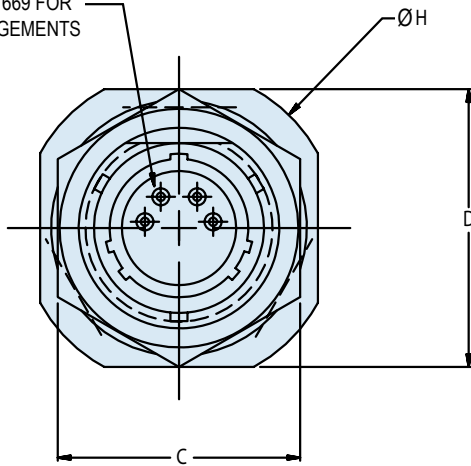

947-292

MIL-DTL-26482 Series II Type Hermetic  
Bayonet Coupling Jam Nut Mount  
Pin-Socket Bulkhead Feedthrough Receptacle



MIL-DTL-26482  
Type

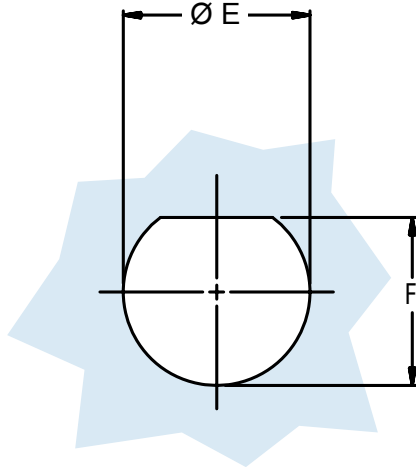

Panel Cut Out

HERMETIC LEAK RATE MOD CODES	
Designator	Required Leak Rate
-585A	1 x 10 <sup>-10</sup> cc Helium per second
-585B	1 x 10 <sup>-9</sup> cc Helium per second
-585C	1 x 10 <sup>-8</sup> cc Helium per second

D

TABLE I: CONNECTOR AND CUT-OUT DIMENSIONS

Shell Size	A Thread Class 2A	B Dia Max	C Hex	D Flats	E Dia +.010 -.005 (+0.3 -0.1)	F Dim +.010 -.005 (+0.3 -0.1)	G Max	H Dia ± .016 (0.4)
8	9/16-24 UNEF	.474 (12.0)	.750 (19.1)	.954 (24.2)	.572 (14.5)	.536 (13.6)	1.420 (36.1)	1.062 (27.0)
10	11/16-24 UNEF	.591 (15.0)	.875 (22.2)	1.078 (27.4)	.697 (17.7)	.661 (16.8)	1.420 (36.1)	1.187 (30.1)
12	7/8-20 UNEF	.751 (19.1)	1.062 (27.0)	1.266 (32.2)	.895 (22.7)	.824 (20.9)	1.420 (36.1)	1.375 (34.9)
14	1-20 UNEF	.876 (22.3)	1.188 (30.2)	1.391 (35.3)	1.010 (25.7)	.948 (24.1)	1.420 (36.1)	1.500 (38.1)
16	1 1/8-18 UNEF	1.001 (25.4)	1.312 (33.3)	1.516 (38.5)	1.135 (28.8)	1.072 (27.2)	1.420 (36.1)	1.625 (41.3)
18	1 1/4-18 UNEF	1.126 (28.6)	1.438 (37.0)	1.641 (41.7)	1.260 (32.0)	1.197 (30.4)	1.420 (36.1)	1.750 (44.5)
20	1 3/8-18 UNEF	1.251 (31.8)	1.562 (39.7)	1.828 (46.4)	1.385 (35.2)	1.322 (33.6)	1.580 (40.1)	1.938 (49.2)
22	1 1/2-18 UNEF	1.376 (35.0)	1.688 (42.9)	1.954 (49.6)	1.510 (38.0)	1.447 (36.8)	1.580 (40.1)	2.062 (52.4)
24	1 5/8-18 UNEF	1.501 (38.1)	1.812 (46.0)	2.087 (53.0)	1.635 (41.5)	1.572 (39.9)	1.620 (41.1)	2.187 (55.5)

APPLICATION NOTES	
1.	To be identified with manufacturer's name, part number and date code, space permitting.
2.	Hermeticity: <1x10 <sup>-7</sup> cc/sec @ 1 ATM differential
3.	Material/Finish: Shell and jam-nut: Z1 - CRES/passivate. ZL - CRES/nickel plate. Titanium and Inconel® available. Consult factory. Contacts - Alloy 52/gold plate. Bayonets - CRES/passivated. Insulator - Vitreous glass seal Seals - Silicone Elastomer/N.A. Spacer - High grade rigid dielectric/N.A.
4.	Metric Dimensions (mm) are indicated in parentheses.

BAYONET AND  
THREADED

# MIL-DTL-83723

*Series III Type  
Hermetic Connectors*



The MIL-DTL-83723 Series III type connector is ideally suited for use on commercial, military and aerospace interconnect systems that demand hermetic sealing and high vibration resistance in a medium density cylindrical connector. Thirty-four insert arrangements are available in both threaded and bayonet coupling styles for a wide range of applications. Because Glenair makes all its hermetic connectors in-house, including the machining of shells, molding of interfacial seals and firing of hermetic components, we can offer you outstanding availability on stock products and fast turnaround on special orders.



**Glenair**<sup>®</sup>

Glenair, Inc.  
1211 Air Way  
Glendale, CA  
91201-2497  
818-247-6000  
sales@glenair.com  
www.glenair.com



# MIL-DTL-83723 Series III Type Threaded and Bayonet Coupling Hermetic Connectors



## MIL-DTL-83723 Series III Threaded and Bayonet Coupling Hermetic Connectors

**Glenair MIL-DTL-83723 Series III Hermetic connectors** are offered in either passivated stainless steel or fused tin over cold rolled carbon steel, with glass insulators fused to the connector shell, and contacts meeting a leak rate of  $1 \times 10^{-7}$  cc/Helium per second.

Maximum design flexibility is built into the MIL-DTL-83723 hermetic connector— with a minimum of 2 to a maximum of 61 circuits per connector in a wide variety of

contact arrangements IAW MIL-STD-1554. Fluorosilicone elastomer interfacial and peripheral seals ensure positive sealing with plug connectors.

Gold plated nickel-iron alloy 52 contacts—available in sizes 12, 16 and 20—depending on the layout chosen—offer a broad selection of insert arrangement options. Solder cup, straight pin and PCB contact styles are standard.

Quick Selection Guide		
Part Number	Description	Page
	MIL-DTL-83723 Series III Type Insert Arrangements	E-2
	Glenair Hermetic Connector Products Space Grade Mod Codes	E-3
	Glenair Hermetic Connector Products Special Leak Rate Mod Codes	E-4
	MIL-DTL-83723 Series III Type Insert Arrangements and Keyway Positions	E-5
<b>230-023</b>	Bayonet Coupling Square Flange Receptacle with Solder Terminals MIL-DTL-83723/79 Type	E-6
<b>230-024</b>	Bayonet Coupling Solder Flange Receptacle with Solder Terminals MIL-DTL-83723/80 Type	E-8
<b>230-025</b>	Bayonet Coupling Jam Nut Receptacle with Solder Terminals MIL-DTL-83723/81 Type	E-10
<b>230-026</b>	Bayonet Coupling Solder Flange Receptacle with Straight Pin Contacts MIL-DTL-83723/93 Type	E-12
<b>230-027</b>	Bayonet Coupling Jam Nut Receptacle with Straight Pin or PCB Contacts MIL-DTL-83723/94 Type	E-14
<b>230-028</b>	Threaded Coupling Square Flange Receptacle with Solder Terminals MIL-DTL-83723/88 Type	E-16
<b>230-029</b>	Threaded Coupling Jam Nut Receptacle with Solder Terminals MIL-DTL-83723/89 Type	E-18
<b>230-030</b>	Threaded Coupling Solder Flange Receptacle with Solder Terminals MIL-DTL-83723/90 Type	E-20



# MIL-DTL-83723 Series III Type Threaded and Bayonet Coupling Insert Arrangements Per MIL-STD-1554

E

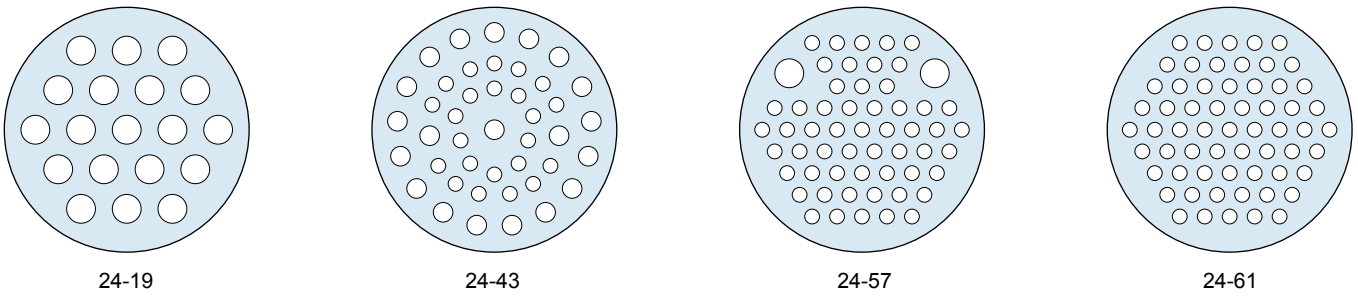
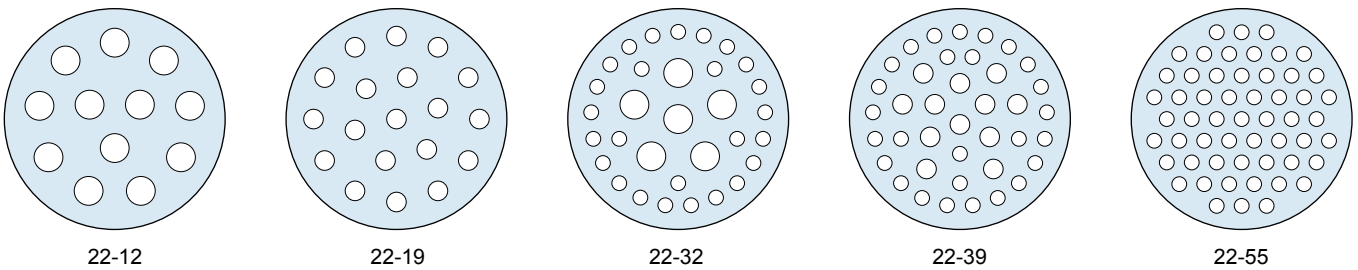
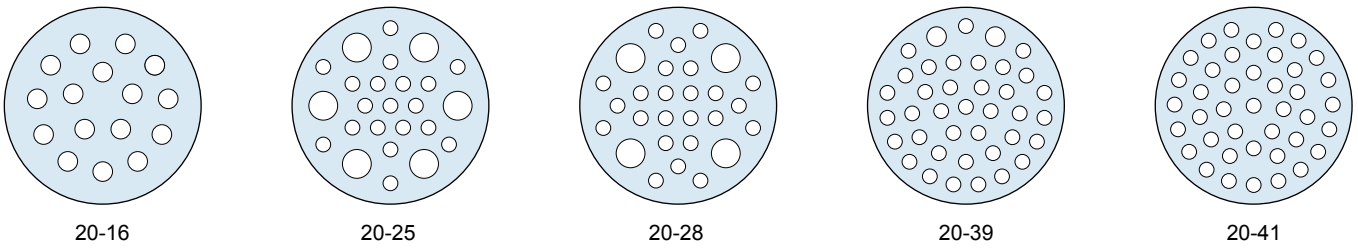
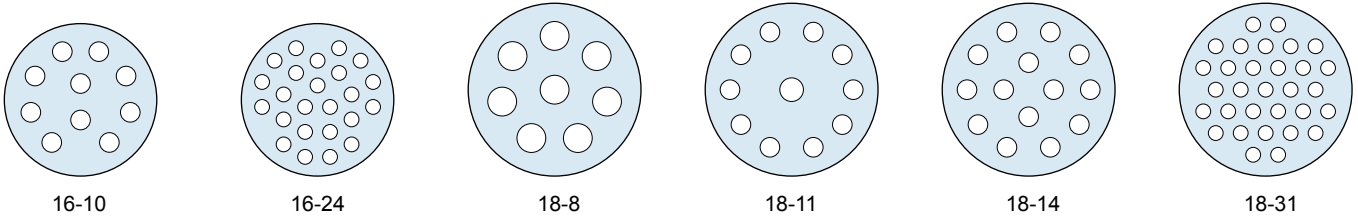
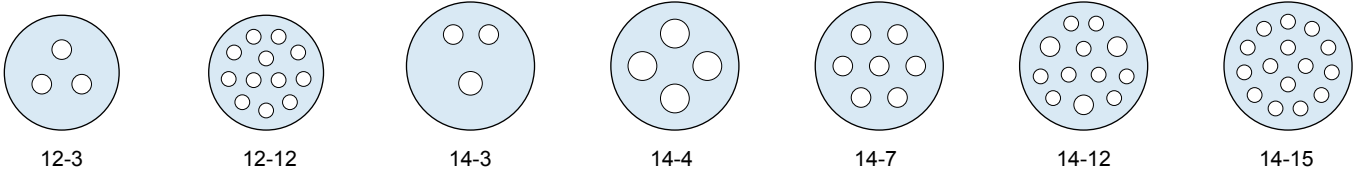
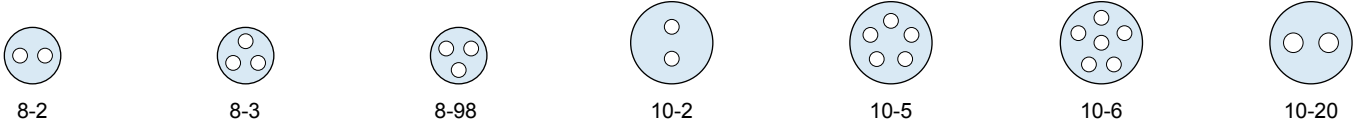

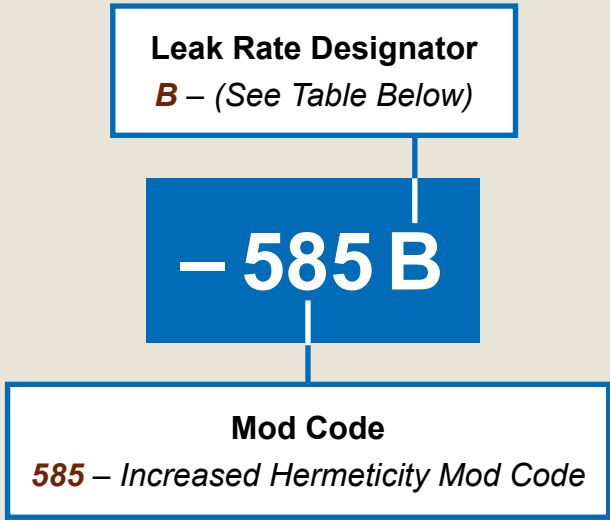

**What is the -585 Mod Code?**

Glenair offers an array of hermetic connectors with more stringent leak rate requirements. By adding “-585” and the designator letter “A”, “B” or “C”—depending on the hermeticity desired—to the end of a standard part number, connectors will be built to exceed the standard  $1 \times 10^{-7}$  cc Helium per second leak rate specified on most Glenair hermetics.

HERMETIC LEAK RATE MOD CODES	
Designator	Required Leak Rate
<b>A</b>	$1 \times 10^{-10}$ cc's Helium per second
<b>B</b>	$1 \times 10^{-9}$ cc's Helium per second
<b>C</b>	$1 \times 10^{-8}$ cc's Helium per second

**Catalog Notes**

For all parts in this catalog:

- All parts will be identified with manufacturer’s name and part number, space permitting.
- Glenair 600 series backshell assembly tools are recommended for assembly and installation.
- Dimensions are subject to change without notice. Metric dimensions appear in parentheses in diagrams and tables, based on 1 inch = 25.4 mm, for reference only. Unless otherwise specified, the following other dimensional tolerances apply:

.xx = ± .03 (0.8)                      Lengths = ± .060 (1.52)  
.xxx = ± .015 (0.4)                      Angles = ± 5°

*Customers are advised to consult the factory for the latest specifications, particularly to confirm critical dimensions such as connector lengths, threads, and so on. When errors or mistakes are brought to our attention, corrected content is posted immediately to [www.glenair.com](http://www.glenair.com).*



## Glenair Hermetic Connector Products Space Grade Mod Codes

### What is outgassing?

Plastic and rubber materials give off gaseous molecules. For example, the smell inside a new car is caused by polymer outgassing. Heat and vacuum increase the rate of diffusion. In a spacecraft the gases coming off polymers can contaminate optical surfaces and instruments. The result is degraded performance.

### How is outgassing measured?

The space industry has adopted a standardized test procedure, **ASTM E 595**, to evaluate out-gassing properties of polymers. Small samples of material are heated to 125° C. at a vacuum of  $5 \times 10^{-5}$  torr for 24 hours. Then the sample is weighed to calculate the **Total Mass Loss** (TML). The TML cannot exceed 1.00% of the total initial mass. During the test, outgassed matter condenses on a cooled collector plate. The quantity of outgassed matter is calculated to determine the **Collected Volatile Condensable Material** (CVCM). The CVCM cannot exceed 0.10% of the original specimen mass.

### What is NASA screening?

NASA specification EEE-INST-002 provides instructions on selecting, screening and qualifying parts for use on NASA GSFC space flight projects.

### What screening level is required?

NASA defines three levels of screening: level 1 for highest reliability, level 2 for high reliability, and level 3 for standard reliability. Level 3 equates to standard lot acceptance inspection. Levels 1 and 2 call for additional testing.

## HOW TO ORDER SPACE GRADE CONNECTORS

### Step 1: Find a Standard Part Number

Electroless nickel plated shells are preferred for space flight. Cadmium plating is prohibited.

### Step 2: Select a NASA Screening Level

The term "Screening Level" refers to the final inspection procedure.

**Level 1** for mission-critical highest reliability

**Level 2** for high reliability

**Level 3** for standard reliability

### Step 3: Choose Outgassing Processing

A detailed explanation of outgassing is on the following pages. The fluorosilicone rubber seals commonly used on aerospace-grade connectors such as MIL-DTL-38999 and Series 79 connectors, along with certain bonding agents and inks, do not meet NASA outgassing requirements unless the connector is specially processed. Glenair outgassing tests have shown oven baking or thermal vacuum outgassing processing are sufficient to reduce outgassing levels to NASA standards. Oven baking is more economical than thermal vacuum outgassing.

### Step 4: Select the Mod 429 Code that Matches the Desired Level of Screening and Outgassing

Use the following table to choose the right modification code. Add the mod code to the connector part number. Example: 790-024PC-13ML-**429C**

## NASA SCREENING LEVELS AND MODIFICATION CODES

NASA Screening Level	Special Screening Only	Special Screening Plus Outgassing Processing	
		8 Hour Oven Bake 400° F.	Thermal Vacuum Outgassing 24 hrs. 125° C.
Level 1 Highest Reliability	Mod 429B	Mod 429J	Mod 429C
Level 2 High Reliability	Mod 429	Mod 429K	Mod 429A
Level 3 Standard Reliability	(Use standard part number)	Mod 186	Mod 186M

# MIL-DTL-83723 Series III Type Threaded and Bayonet Coupling Insert Arrangements and Keyway Positions



MIL-DTL-83723  
Type

Insert Arrangements					
Shell Size Designator	Insert Arrangement Dash Number	Service Rating	Contact Size and Quantity		
			20	16	12
08	08-02	I	2		
	08-03	I	3		
	08-98	I	3		
10	10-02	I	2		
	10-05	I	5		
	10-06	I	6		
	10-20	I		2	
12	12-03	I		3	
	12-12	I	12		
14	14-03*	I		3*	
	14-04	I			4
	14-07	I		7	
	14-12	I	9	3	
	14-15	I	15		
16	16-10	I		10	
	16-24	I	24		
18	18-08	I			8
	18-11*	I		11*	
	18-14	I		14	
	18-31	I	31		
	18-31	I	31		
20	20-16	I		16	
	20-25	I	19		6
	20-28	I	24		4
	20-39	I	37	2	
	20-41	I	41		
22	22-12	I			12
	22-19	I		19	
	22-32	I	26		6
	22-39	I	27	12	
	22-55	I	55		
24	24-19	I			19
	24-43	I	23	20	
	24-57	I	55		2
	24-61	I	61		

\*1 shielded.

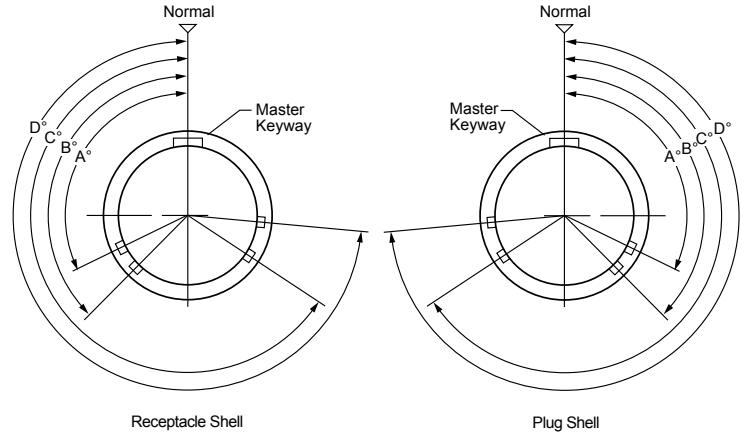

Keyway Positions (Front Face of Pin Insert)					
Shell Size	Keyway Position	A°	B°	C°	D°
08 through 10	Normal	105°	140°	215°	265°
	6	102°	132°	248°	320°
	7	80°	118°	230°	312°
	8	35°	140°	205°	275°
	9	64°	155°	234°	304°
	Y or 10	25°	115°	220°	270°
12 through 24	Normal	105°	140°	215°	265°
	6	18°	149°	192°	259°
	7	92°	152°	222°	342°
	8	84°	152°	204°	334°
	9	24°	135°	199°	240°
	Y or 10	98°	152°	268°	338°

Y Position not available for shell size 8.  
Use "Y" when ordering military parts, "10" when ordering commercial parts



## MIL-DTL-83723/79 Series III Type Hermetic Bayonet Coupling Square Flange Receptacle Connector with Solder Terminals

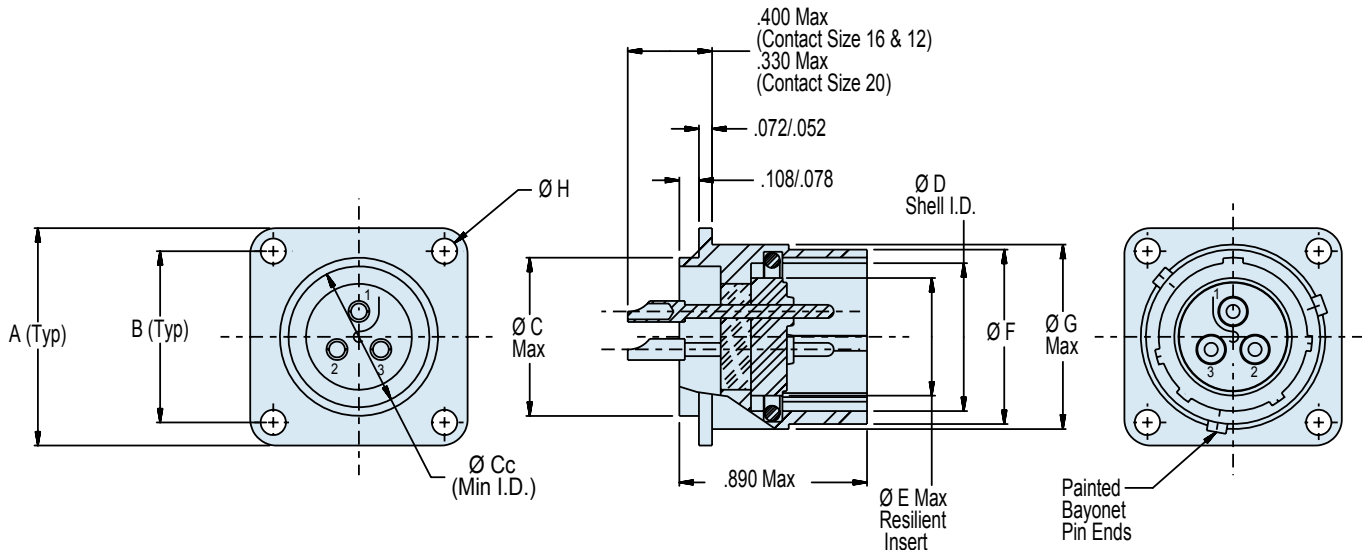
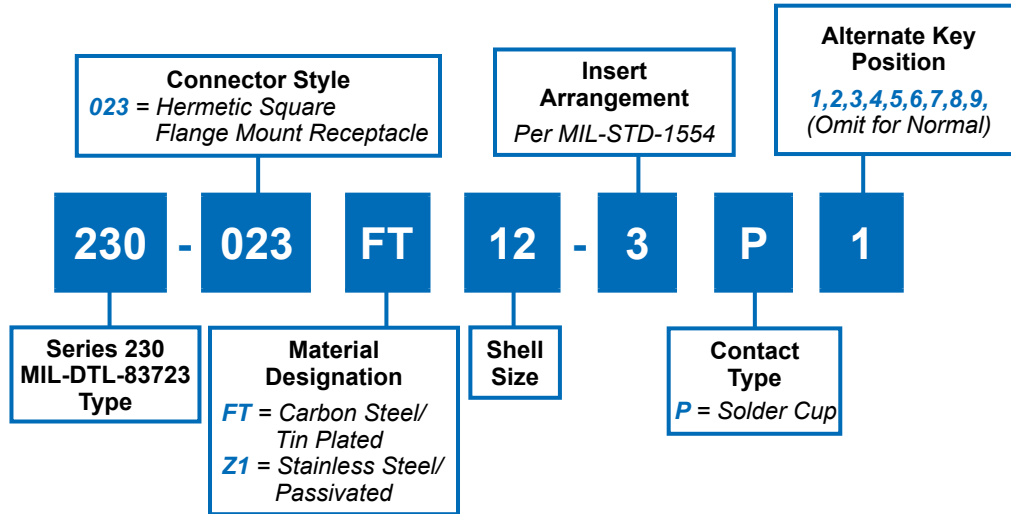

### APPLICATION NOTES

- To be identified with manufacturer's name, part number and date code, space permitting.
- Material/Finish:  
Shell\*:  
Z1 - Stainless steel/passivated.  
FT - Carbon steel/tin plated.  
Contacts - 52 Nickel alloy/gold plated.  
Bayonets - Stainless steel/passivated.  
Seals - Silicone elastomer/N.A.  
Insulation - Glass/N.A.
- Glenair 230-023 will mate with any QPL MIL-DTL-83723/75 & 77 Series III bayonet coupling plug of same size, keyway, and insert polarization.
- Performance:  
Hermeticity -  $<1 \times 10^{-7}$  cc He/sec @ 1 atmosphere differential.  
Dielectric withstanding voltage - Consult factory or MIL-STD-1554.  
Insulation resistance - 5000 MegOhms min. @ 500VDC.
- Consult factory and/or MIL-STD-1554 for arrangement, keyway, and insert position options.
- Metric Dimensions (mm) are indicated in parentheses.

\* Additional shell materials available, including titanium and Inconel®. Consult factory for ordering information.

230-023

MIL-DTL-83723/79 Series III Type Hermetic  
Bayonet Coupling Square Flange Receptacle Connector  
with Solder Terminals



MIL-DTL-83723  
Type

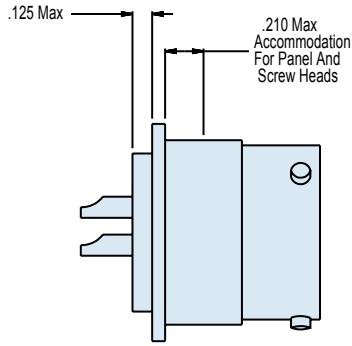

Max Panel Thickness

HERMETIC LEAK RATE MOD CODES	
Designator	Required Leak Rate
-585A	1 x 10 <sup>-10</sup> cc Helium per second
-585B	1 x 10 <sup>-9</sup> cc Helium per second
-585C	1 x 10 <sup>-8</sup> cc Helium per second

E

TABLE I: CONNECTOR AND CUT-OUT DIMENSIONS

Shell Size	A	B	C Dia Max	D Dia Shell I.D.	E Dia Resilient Insert	F Dia	G Dia Max	H Dia Thru 4 Pl	CC Dia Min	Panel Cut-Out Ø C	Panel Cut-Out Ø G
8	.812 (20.6)	.594 (15.1)	.500 (12.7)	.433/.428 (11.0/10.9)	.312 (7.9)	.536/.531 (13.6/13.5)	.561 (14.2)	.120 (3.0)	.406 (10.3)	.630/.620 (16.0/15.7)	.515/.505 (13.1/12.8)
10	.937 (23.8)	.719 (18.3)	.562 (14.3)	.535/.530 (13.6/13.5)	.388 (9.9)	.659/.654 (16.7/16.6)	.696 (17.7)	.120 (3.0)	.443 (11.3)	.758/.748 (19.3/19.0)	.582/.572 (14.8/14.5)
12	1.031 (26.2)	.812 (20.6)	.750 (19.1)	.705/.700 (17.9/17.8)	.558 (14.2)	.829/.824 (21.1/20.9)	.875 (22.2)	.120 (3.0)	.668 (17.0)	.923/.913 (23.4/23.2)	.770/.760 (19.6/19.3)
14	1.125 (28.6)	.906 (23.0)	.812 (20.6)	.774/.769 (19.7/19.5)	.627 (15.9)	.898/.893 (22.8/22.7)	.935 (23.7)	.120 (3.0)	.668 (17.0)	.990/.980 (25.1/24.8)	.832/.822 (21.1/20.9)
16	1.250 (31.8)	.969 (24.6)	.937 (23.8)	.901/.896 (22.9/22.8)	.772 (19.6)	1.025/1.020 (26.0/25.9)	1.062 (27.0)	.120 (3.0)	.763 (19.4)	1.117/1.107 (28.4/28.1)	.958/.948 (24.3/24.1)
18	1.343 (34.1)	1.062 (27.0)	1.062 (27.0)	1.007/1.002 (25.6/25.5)	.860 (21.8)	1.131/1.126 (28.7/28.6)	1.187 (30.1)	.120 (3.0)	.862 (21.9)	1.219/1.209 (31.0/30.7)	1.082/1.072 (27.5/27.2)
20	1.437 (36.5)	1.156 (29.4)	1.187 (30.1)	1.132/1.125 (28.8/28.6)	.985 (25.0)	1.256/1.251 (31.9/31.8)	1.312 (33.3)	.120 (3.0)	1.108 (28.1)	1.347/1.337 (34.2/34.0)	1.202/1.192 (30.5/30.3)
22	1.562 (39.7)	1.250 (31.8)	1.312 (33.3)	1.257/1.252 (31.9/31.8)	1.110 (28.2)	1.381/1.376 (35.1/35.0)	1.437 (36.5)	.120 (3.0)	1.204 (30.6)	1.462/1.452 (37.1/36.9)	1.332/1.322 (33.8/33.6)
24	1.703 (43.3)	1.375 (34.9)	1.437 (36.5)	1.382/1.377 (35.1/35.0)	1.235 (31.4)	1.506/1.501 (38.3/38.1)	1.562 (39.7)	.149 (3.8)	1.388 (35.3)	1.587/1.577 (40.3/40.1)	1.452/1.442 (36.9/36.6)





**230-024**  
**MIL-DTL-83723/80 Series III Type Hermetic**  
**Bayonet Coupling Solder Flange Mount Receptacle**  
**with Solder Cup Terminals**

E

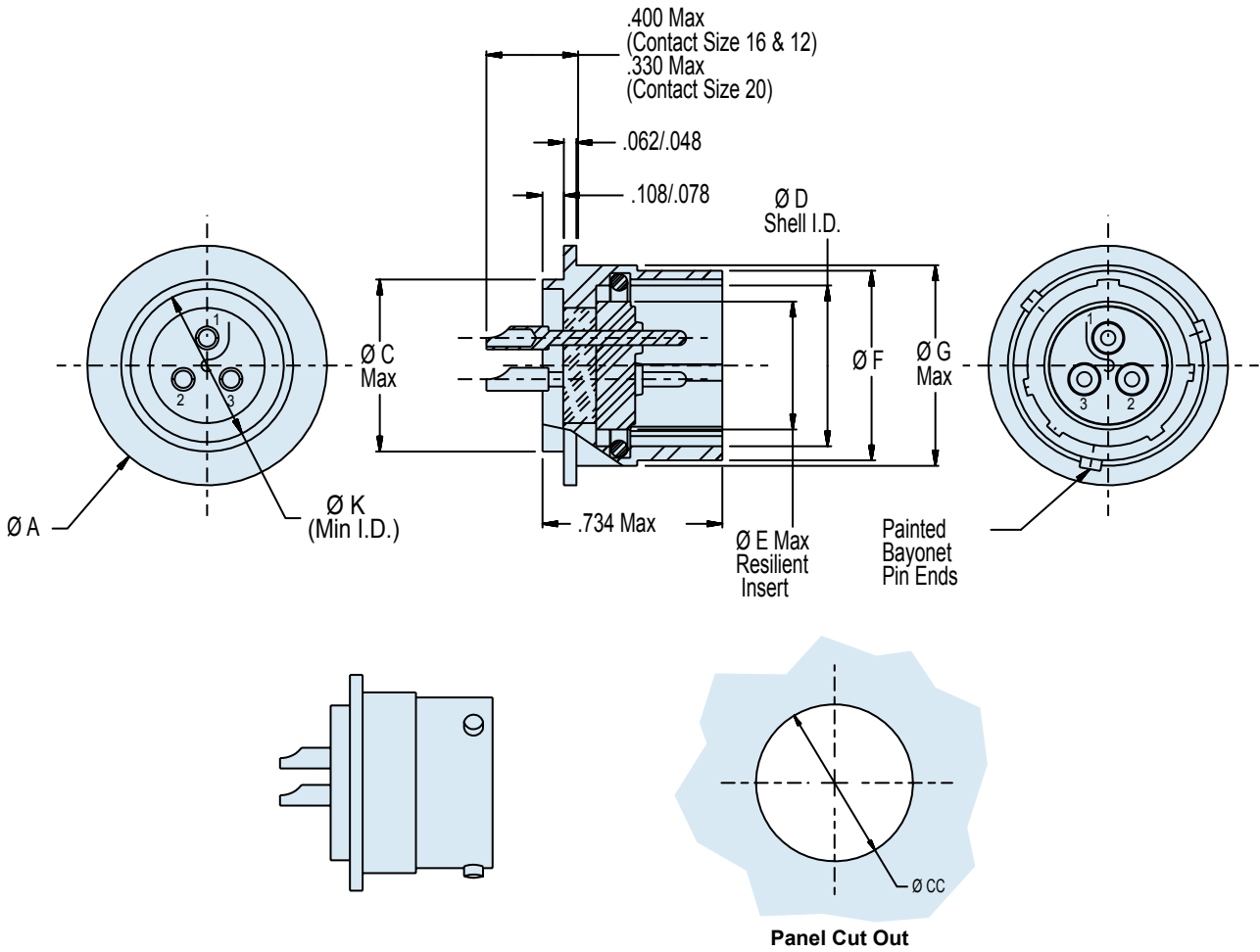
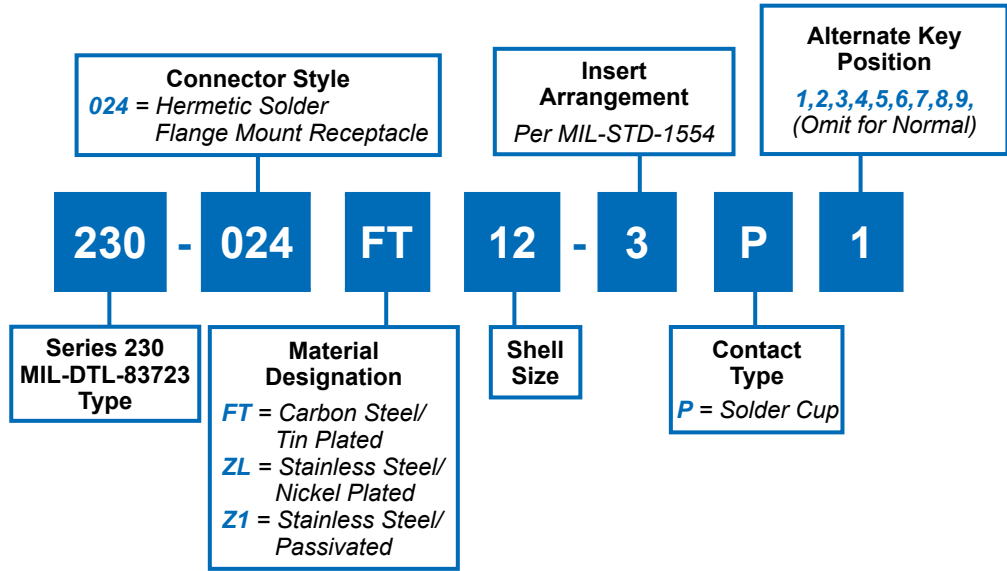

230-024

# MIL-DTL-83723/80 Series III Type Hermetic Bayonet Coupling Solder Flange Mount Receptacle with Solder Cup Terminals

MIL-DTL-83723  
Type

HERMETIC LEAK RATE MOD CODES	
Designator	Required Leak Rate
-585A	1 x 10 <sup>-10</sup> cc Helium per second
-585B	1 x 10 <sup>-9</sup> cc Helium per second
-585C	1 x 10 <sup>-8</sup> cc Helium per second

TABLE I: CONNECTOR AND CUT-OUT DIMENSIONS

Shell Size	A	C Dia Max	D Dia Shell I.D.	E Dia Resilient Insert	F Dia	G Dia Max	K Dia Min	Panel Cut-Out Ø CC
8	.760/.720 (19.3/18.3)	.500 (12.7)	.433/.428 (11.0/10.9)	.312 (7.9)	.536/.531 (13.6/13.5)	.561 (14.2)	.406 (10.3)	.515/.505 (13.1/12.8)
10	.860/.820 (21.8/20.8)	.562 (14.3)	.535/.530 (13.6/13.5)	.388 (9.9)	.659/.654 (16.7/16.6)	.696 (17.7)	.443 (11.3)	.577/.567 (14.7/14.4)
12	1.065/1.025 (27.1/26.0)	.750 (19.1)	.705/.700 (17.9/17.8)	.558 (14.2)	.829/.824 (21.1/20.9)	.875 (22.2)	.668 (17.0)	.765/.755 (19.4/19.2)
14	1.110/1.070 (28.2/27.2)	.812 (20.6)	.774/.769 (19.7/19.5)	.627 (15.9)	.898/.893 (22.8/22.7)	.935 (23.7)	.668 (17.0)	.827/.812 (21.0/20.6)
16	1.230/1.190 (31.2/30.2)	.937 (23.8)	.901/.896 (22.9/22.8)	.772 (19.6)	1.025/1.020 (26.0/25.9)	1.062 (27.0)	.763 (19.4)	.962/.942 (24.4/23.9)
18	1.360/1.320 (34.5/33.5)	1.062 (27.0)	1.007/1.002 (25.6/25.5)	.860 (21.8)	1.131/1.126 (28.7/28.6)	1.187 (30.1)	.862 (21.9)	1.077/1.067 (27.4/27.1)
20	1.450/1.410 (36.8/35.8)	1.187 (30.1)	1.132/1.125 (28.8/28.6)	.985 (25.0)	1.256/1.251 (31.9/31.8)	1.312 (33.3)	1.108 (28.1)	1.202/1.192 (30.5/30.3)
22	1.610/1.570 (40.9/39.9)	1.312 (33.3)	1.257/1.252 (31.9/31.8)	1.110 (28.2)	1.381/1.376 (35.1/35.0)	1.437 (36.5)	1.204 (30.6)	1.327/1.317 (33.7/33.5)
24	1.730/1.690 (43.9/42.9)	1.437 (36.5)	1.382/1.377 (35.1/35.0)	1.235 (31.4)	1.506/1.501 (38.3/38.1)	1.562 (39.7)	1.388 (35.3)	1.452/1.442 (36.9/36.6)

## APPLICATION NOTES

- To be identified with manufacturer's name, part number and date code, space permitting.
- Material/Finish\*:  
Shell:  
Z1 - Stainless steel/passivated  
ZL - Stainless steel/Nickel Plated  
FT - Carbon steel/tin plated  
Contacts - 52 Nickel alloy/gold plated  
Bayonets - Stainless steel/passivated  
Seals - Silicone elastomer/N.A.  
Insulation - Glass/N.A.
- Glenair 230-024 will mate with any QPL MIL-DTL-83723/75 & 77 Series III bayonet coupling plug of same size, keyway, and insert polarization.
- Performance:  
Hermeticity <1 x 10<sup>-7</sup> cc He/sec @ 1 atmosphere differential.  
Dielectric withstanding voltage - Consult factory or MIL-STD-1554.  
Insulation resistance - 5000 MegOhms min @ 500VDC.
- Consult factory and/or MIL-STD-1554 for arrangement, keyway, and insert position options.
- Metric Dimensions (mm) are indicated in parentheses.

\* Additional shell materials available, including titanium and Inconel®. Consult factory for ordering information.



**230-025**  
**MIL-DTL-83723/81 Series III Type Hermetic**  
**Bayonet Coupling Jam-Nut Mount Receptacle**  
**with Solder Cup Terminals**

**E**

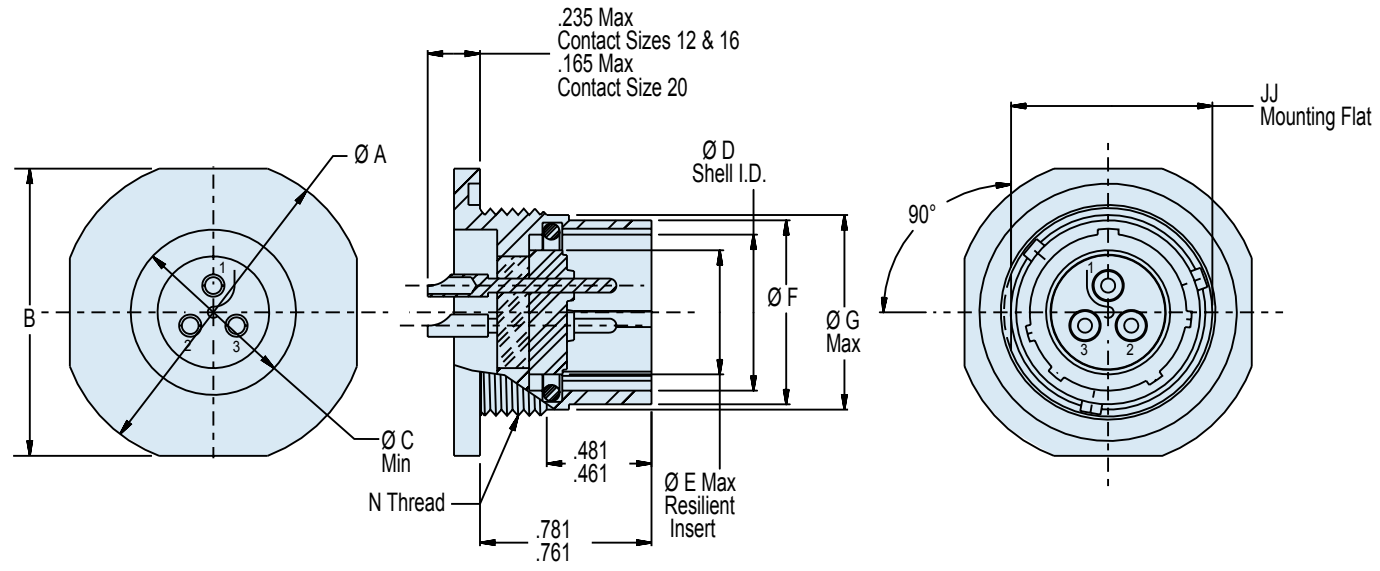
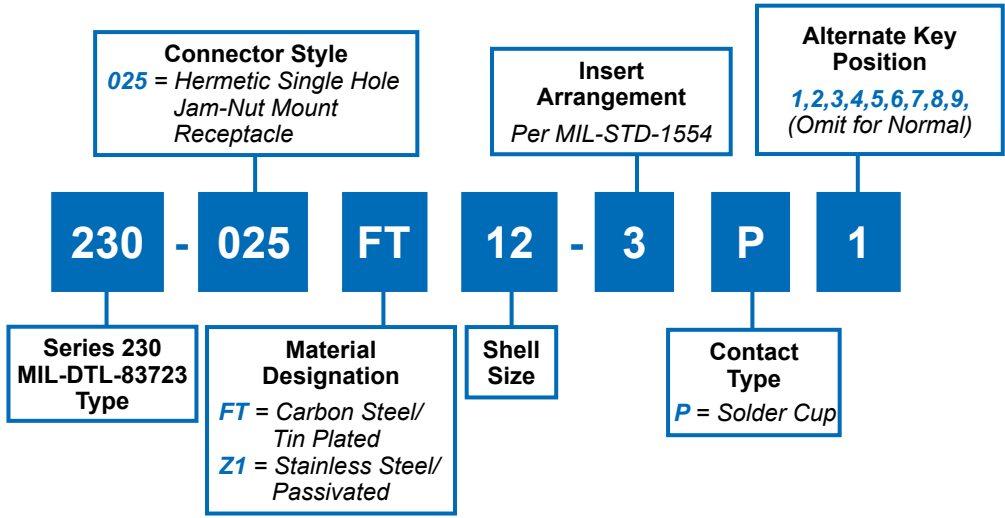

**APPLICATION NOTES**

- |  |   |
|--|---|
| <p>1. To be identified with manufacturer's name, part number and date code, space permitting.</p> <p>2. Material/Finish:<br/>         Shell* and Jam-Nut:<br/>             Z1 - Stainless steel/passivated.<br/>             FT - Carbon steel/tin plated.<br/>         Contacts - 52 Nickel alloy/gold plated.<br/>         Bayonets - Stainless steel/passivated.<br/>         Seals - Silicone elastomer/N.A.<br/>         Insulation - Glass/N.A.</p> <p>3. Glenair 230-025 will mate with any QPL MIL-DTL-83723/75 &amp; 77 Series III bayonet coupling plug of same size, keyway, and insert polarization.</p> | <p>4. Performance:<br/>         Hermeticity &lt;math&gt; &lt; 1 \times 10^{-7}&lt;/math&gt; cc He/sec @ 1 atmosphere differential.<br/>         Dielectric withstanding voltage - Consult factory or MIL-STD-1554.<br/>         Insulation resistance - 5000 MegOhms min @ 500VDC.</p> <p>5. Consult factory and/or MIL-STD-1554 for arrangement, keyway, and insert position options.</p> <p>6. Metric Dimensions (mm) are indicated in parentheses.</p> |
|--|---|

\* Additional shell materials available, including titanium and Inconel®. Consult factory for ordering information.

**230-025**  
**MIL-DTL-83723/81 Series III Type Hermetic**  
**Bayonet Coupling Jam-Nut Mount Receptacle**  
**with Solder Cup Terminals**



MIL-DTL-83723  
Type

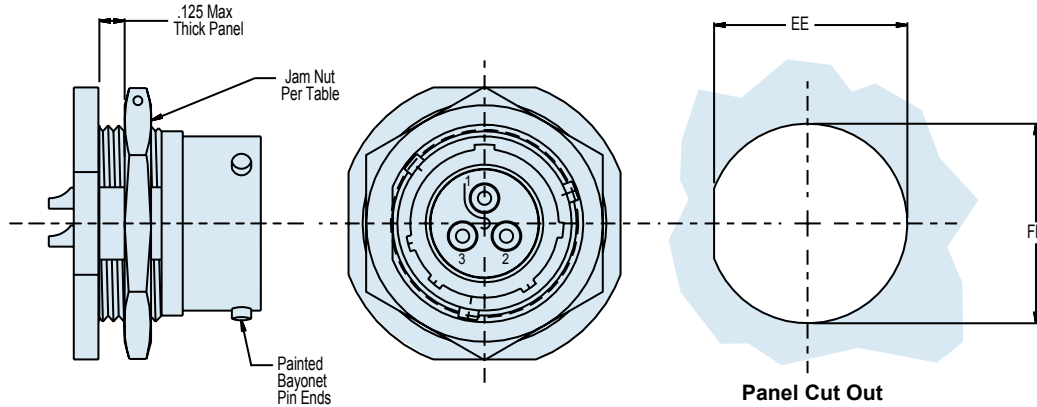

HERMETIC LEAK RATE MOD CODES	
Designator	Required Leak Rate
-585A	1 x 10 <sup>-10</sup> cc Helium per second
-585B	1 x 10 <sup>-9</sup> cc Helium per second
-585C	1 x 10 <sup>-8</sup> cc Helium per second

E

**TABLE I: CONNECTOR AND CUT-OUT DIMENSIONS**

Shell Size	A Dia Max	B	C Dia Min	D Dia Shell I.D.	E Dia Resilient Insert	F Dia	G Dia Max	N Thread	JJ Mounting Flat	Panel Cut-Out EE +.000 -.002 (.05)	Panel Cut-Out FF DIA ±.005 (0.1)	Jam Nut MS3186
8	1.068 (27.1)	.979 (24.9)	.493 (12.5)	.433/.428 (11.0/10.9)	.312 (7.9)	.536/.531 (13.6/13.5)	.561 (14.2)	.625-20 UN-2A	.596/.590 (15.1/15.0)	.605 (15.4)	.635 (16.1)	-105
10	1.192 (30.3)	1.104 (28.0)	.555 (14.1)	.535/.530 (13.6/13.5)	.388 (9.9)	.659/.654 (16.7/16.6)	.696 (17.7)	.750-20 UNEF-2A	.721/.715 (18.3/18.2)	.730 (18.5)	.760 (19.3)	-107
12	1.380 (35.1)	1.291 (32.8)	.743 (18.9)	.705/.700 (17.9/17.8)	.558 (14.2)	.829/.824 (21.1/20.9)	.875 (22.2)	.937-20 UNEF-2A	.908/.902 (23.1/22.9)	.917 (23.3)	.947 (24.1)	-110
14	1.505 (38.2)	1.391 (35.3)	.805 (20.4)	.774/.769 (19.7/19.5)	.627 (15.9)	.898/.893 (22.8/22.7)	.935 (23.7)	1.000-20 UNEF-2A	.971/.965 (24.7/24.5)	.980 (24.9)	1.010 (25.7)	-111
16	1.630 (41.4)	1.516 (38.5)	.931 (23.6)	.901/.896 (22.9/22.8)	.772 (19.6)	1.025/1.020 (26.0/25.9)	1.062 (27.0)	1.125-20 UNEF-2A	1.096/1.090 (27.8/27.7)	1.105 (28.1)	1.135 (32.1)	-112
18	1.765 (44.8)	1.641 (41.7)	1.055 (26.8)	1.007/1.002 (25.6/25.5)	.860 (21.8)	1.131/1.126 (28.7/28.6)	1.187 (30.1)	1.250-18 UNEF-2A	1.220/1.214 (31.0/30.8)	1.229 (31.2)	1.260 (32.0)	-116
20	1.860 (47.2)	1.766 (44.9)	1.243 (31.6)	1.132/1.125 (28.8/28.6)	.985 (25.0)	1.256/1.251 (31.9/31.8)	1.312 (33.3)	1.375-18 UNEF-2A	1.345/1.339 (34.2/34.0)	1.354 (34.4)	1.385 (35.2)	-117
22	2.068 (52.5)	1.954 (49.6)	1.305 (33.1)	1.257/1.252 (31.9/31.8)	1.110 (28.2)	1.381/1.376 (35.1/35.0)	1.437 (36.5)	1.500-18 UNEF-2A	1.470/1.464 (37.3/37.2)	1.479 (37.6)	1.510 (38.4)	-120
24	2.160 (54.9)	2.079 (52.8)	1.493 (37.9)	1.382/1.377 (35.1/35.0)	1.235 (31.4)	1.506/1.501 (38.3/38.1)	1.562 (39.7)	1.625-18 UNEF-2A	1.595/1.589 (40.5/40.4)	1.604 (40.7)	1.635 (41.5)	-121



**230-026**  
**MIL-DTL-83723/93 Series III Type Hermetic Bayonet Coupling Solder Flange Mount Receptacle with Straight Pin Contacts**

E

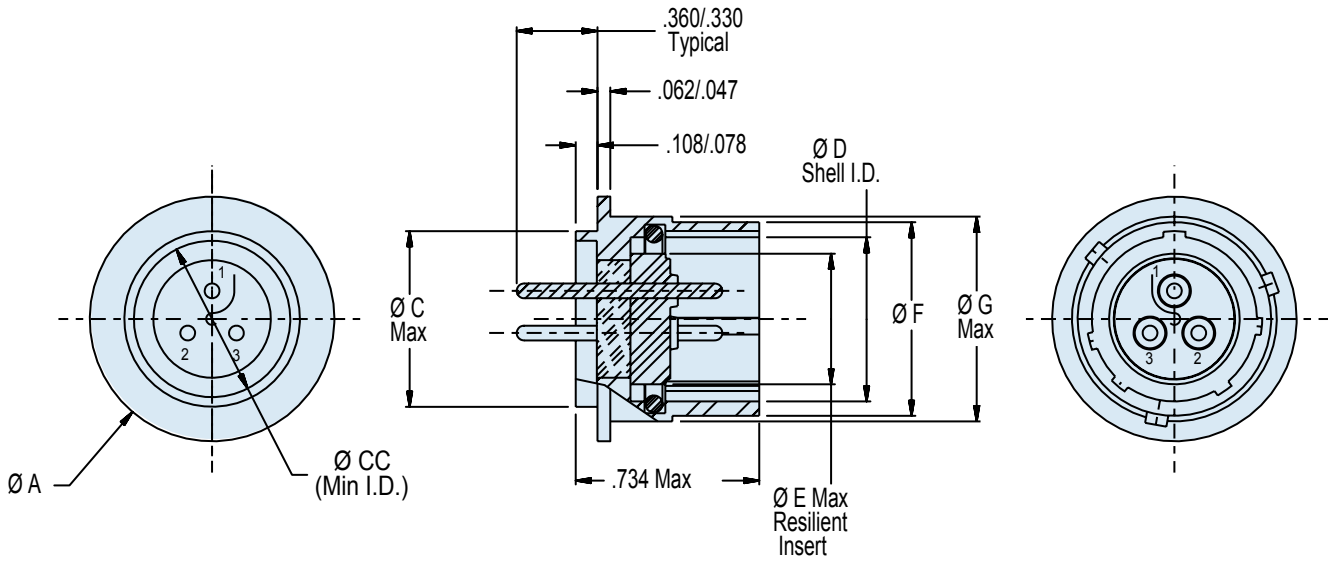
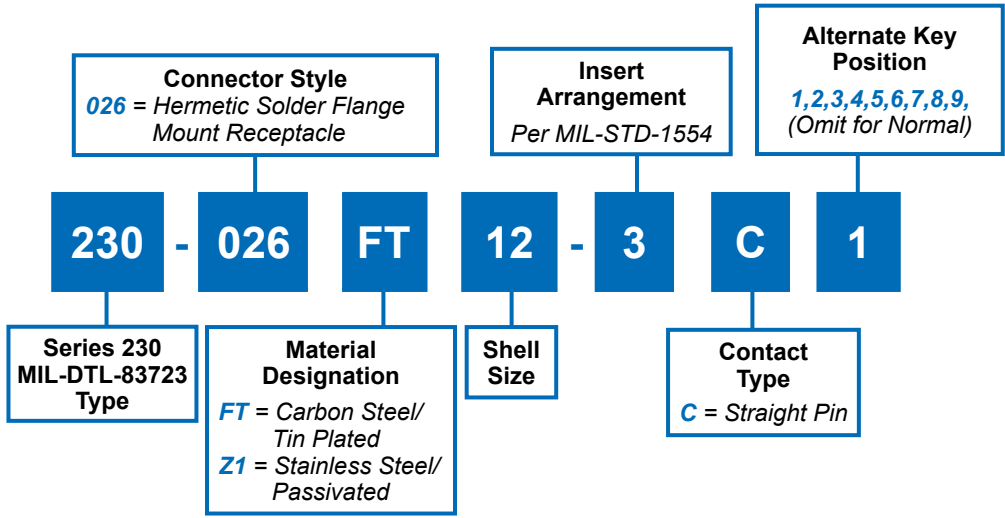

**APPLICATION NOTES**

- To be identified with manufacturer's name, part number and date code, space permitting.
- Material/Finish:  
Shell\*:  
Z1 - Stainless steel/passivated.  
FT - Carbon steel/tin plated.  
Contacts - 52 Nickel alloy/gold plated.  
Bayonets - Stainless steel/passivated.  
Seals - Silicone elastomer/N.A.  
Insulation - Glass/N.A.
- Glenair 230-026 will mate with any QPL MIL-DTL-83723/75 & 77 Series III bayonet coupling plug of same size, keyway, and insert polarization.
- Performance:  
Hermeticity <math>1 \times 10^{-7}</math> cc He/sec @ 1 atmosphere differential.  
Dielectric withstanding voltage - Consult factory or MIL-STD-1554.  
Insulation resistance - 5000 MegOhms min @ 500VDC.
- Consult factory and/or MIL-STD-1554 for arrangement, keyway, and insert position options.
- Consult factory for PC tail footprints.
- Metric Dimensions (mm) are indicated in parentheses.

\* Additional shell materials available, including titanium and Inconel®. Consult factory for ordering information.

230-026

MIL-DTL-83723/93 Series III Type Hermetic  
Bayonet Coupling Solder Flange Mount Receptacle  
with Straight Pin Contacts



MIL-DTL-83723  
Type

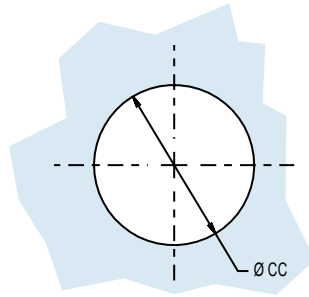

Panel Cut Out

E

HERMETIC LEAK RATE MOD CODES	
Designator	Required Leak Rate
-585A	1 x 10 <sup>-10</sup> cc Helium per second
-585B	1 x 10 <sup>-9</sup> cc Helium per second
-585C	1 x 10 <sup>-8</sup> cc Helium per second

TABLE I: CONNECTOR AND CUT-OUT DIMENSIONS								
Shell Size	A Dia	C Dia Max	D Dia Shell I.D.	E Dia Resilient Insert	F Dia	G Dia Max	CC Dia Min	Ø CC Dia Panel Cut-Out
8	.760/.720 (19.3/18.3)	.500 (12.7)	.433/.428 (11.0/10.9)	.312 (7.9)	.536/.531 (13.6/13.5)	.561 (14.2)	.406 (10.3)	.515/.505 (13.1/12.8)
10	.860/.820 (21.8/20.8)	.562 (14.3)	.535/.530 (13.6/13.5)	.388 (9.9)	.659/.654 (16.7/16.6)	.696 (17.7)	.443 (11.3)	.577/.567 (14.7/14.4)
12	1.065/1.025 (27.1/26.0)	.750 (19.1)	.705/.700 (17.9/17.8)	.558 (14.2)	.829/.824 (21.1/20.9)	.875 (22.2)	.668 (17.0)	.765/.755 (19.4/19.2)
14	1.110/1.070 (28.2/27.2)	.812 (20.6)	.774/.769 (19.7/19.5)	.627 (15.9)	.898/.893 (22.8/22.7)	.935 (23.7)	.668 (17.0)	.827/.812 (21.0/20.6)
16	1.230/1.190 (31.2/30.2)	.937 (23.8)	.901/.896 (22.9/22.8)	.772 (19.6)	1.025/1.020 (26.0/25.9)	1.062 (27.0)	.763 (19.4)	.962/.942 (24.4/23.9)
18	1.360/1.320 (34.5/33.5)	1.062 (27.0)	1.007/1.002 (25.6/25.5)	.860 (21.8)	1.131/1.126 (28.7/28.6)	1.187 (30.1)	.862 (21.9)	1.077/1.067 (27.4/27.1)
20	1.450/1.410 (36.8/35.8)	1.187 (30.1)	1.132/1.125 (28.8/28.6)	.985 (25.0)	1.256/1.251 (31.9/31.8)	1.312 (33.3)	1.108 (28.1)	1.202/1.192 (30.5/30.3)
22	1.610/1.570 (40.9/39.9)	1.312 (33.3)	1.257/1.252 (31.9/31.8)	1.110 (28.2)	1.381/1.376 (35.1/35.0)	1.437 (36.5)	1.204 (30.6)	1.327/1.317 (33.7/33.5)
24	1.730/1.690 (43.9/42.9)	1.437 (36.5)	1.382/1.377 (35.1/35.0)	1.235 (31.4)	1.506/1.501 (38.3/38.1)	1.562 (39.7)	1.388 (35.3)	1.452/1.442 (36.9/36.6)

## MIL-DTL-83723/94 Series III Type Hermetic Bayonet Coupling Jam-Nut Mount Receptacle with Straight Pin (All Sizes) or PCB (Size 20 Only) Contacts

**Connector Style**  
027 = Hermetic Single Hole  
Jam-Nut Mount  
Receptacle

**Insert  
Arrangement**  
Per MIL-STD-1554

**Alternate Key  
Position**  
1,2,3,4,5,6,7,8,9,  
(Omit for Normal)

230

- 027

FT

12

- 3

C

1

**Series 230  
MIL-DTL-83723  
Type**

**Material  
Designation**  
FT = Carbon Steel/  
Tin Plated  
Z1 = Stainless Steel/  
Passivated

**Shell  
Size**

**Contact Type**

C = Straight Pin  
PC = Flex Circuit Pin,  
Size 20 Only.

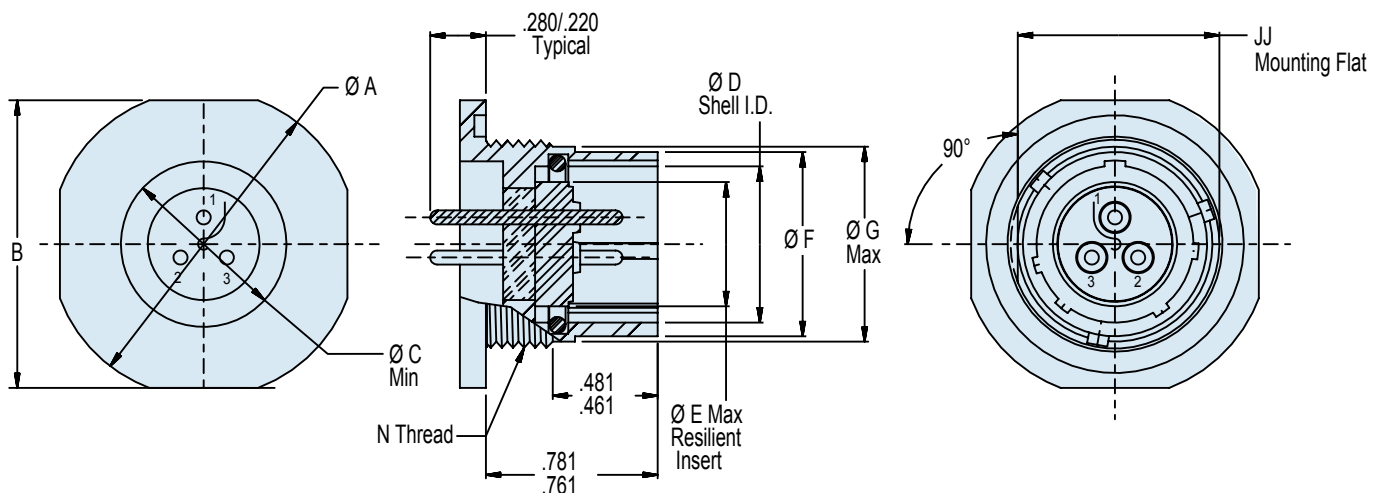

### APPLICATION NOTES

- To be identified with manufacturer's name, part number and date code, space permitting.
- Material/Finish:  
Shell\* and Jam-Nut:  
Z1 - Stainless steel/passivated.  
FT - Carbon steel/tin plated.  
Contacts - 52 Nickel alloy/gold plated.  
Bayonets - Stainless steel/passivated.  
Seals - Silicone elastomer/N.A.  
Insulation - Glass/N.A.
- Glenair 230-027 will mate with any QPL MIL-DTL-83723/75 & 77 Series III bayonet coupling plug of same size, keyway, and insert polarization.
- Performance:  
Hermeticity  $< 1 \times 10^{-7}$  cc He/sec @ 1 atmosphere differential.  
Dielectric withstanding voltage - Consult factory or MIL-STD-1554.  
Insulation resistance - 5000 MegOhms min @ 500VDC.
- Consult factory and/or MIL-STD-1554 for arrangement, keyway, and insert position options.
- Consult factory for PC tail footprints.
- Metric Dimensions (mm) are indicated in parentheses.

\* Additional shell materials available, including titanium and Inconel®. Consult factory for ordering information.



230-027

MIL-DTL-83723/94 Series III Type Hermetic  
Bayonet Coupling Jam-Nut Mount Receptacle  
with Straight Pin (All Sizes) or PCB (Size 20 Only) Contacts



MIL-DTL-83723  
Type

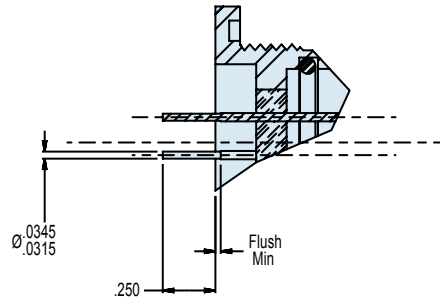
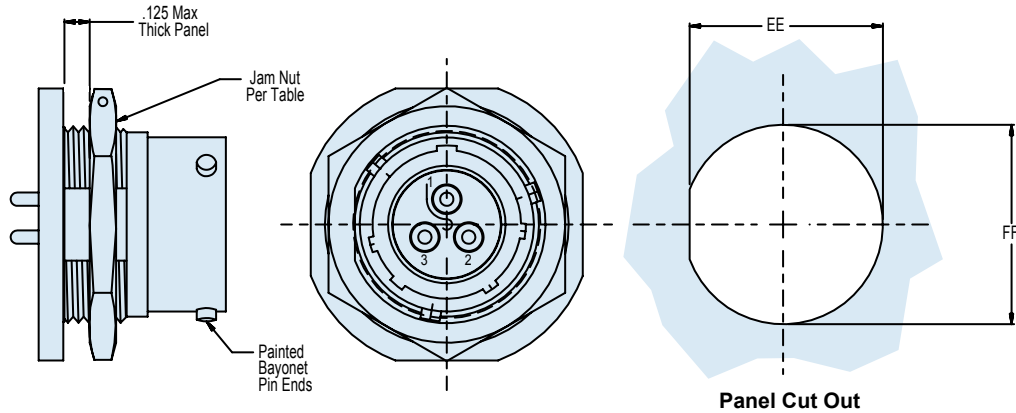

Flex Circuit  
Contact Detail

HERMETIC LEAK RATE MOD CODES	
Designator	Required Leak Rate
-585A	1 x 10 <sup>-10</sup> cc Helium per second
-585B	1 x 10 <sup>-9</sup> cc Helium per second
-585C	1 x 10 <sup>-8</sup> cc Helium per second

TABLE I: CONNECTOR AND CUT-OUT DIMENSIONS

Shell Size	A Dia Max	B	C Dia Min	D Dia Shell I.D.	E Dia Resilient Insert	F Dia	G Dia Max	N Thread	JJ Mounting Flat	Panel Cut-Out EE +.000 -.002 (.05)	Panel Cut-Out FF DIA ±.005 (0.1)	Jam Nut MS3186
8	1.068 (27.1)	.979 (24.9)	.493 (12.5)	.433/.428 (11.0/10.9)	.312 (7.9)	.536/.531 (13.6/13.5)	.561 (14.2)	.625-20 UN-2A	.596/.590 (15.1/15.0)	.605 (15.4)	.635 (16.1)	-105
10	1.192 (30.3)	1.104 (28.0)	.555 (14.1)	.535/.530 (13.6/13.5)	.388 (9.9)	.659/.654 (16.7/16.6)	.696 (17.7)	.750-20 UNEF-2A	.721/.715 (18.3/18.2)	.730 (18.5)	.760 (19.3)	-107
12	1.380 (35.1)	1.291 (32.8)	.743 (18.9)	.705/.700 (17.9/17.8)	.558 (14.2)	.829/.824 (21.1/20.9)	.875 (22.2)	.937-20 UNEF-2A	.908/.902 (23.1/22.9)	.917 (23.3)	.947 (24.1)	-110
14	1.505 (38.2)	1.391 (35.3)	.805 (20.4)	.774/.769 (19.7/19.5)	.627 (15.9)	.898/.893 (22.8/22.7)	.935 (23.7)	1.000-20 UNEF-2A	.971/.965 (24.7/24.5)	.980 (24.9)	1.010 (25.7)	-111
16	1.630 (41.4)	1.516 (38.5)	.931 (23.6)	.901/.896 (22.9/22.8)	.772 (19.6)	1.025/1.020 (26.0/25.9)	1.062 (27.0)	1.125-20 UNEF-2A	1.096/1.090 (27.8/27.7)	1.105 (28.1)	1.135 (32.1)	-112
18	1.765 (44.8)	1.641 (41.7)	1.055 (26.8)	1.007/1.002 (25.6/25.5)	.860 (21.8)	1.131/1.126 (28.7/28.6)	1.187 (30.1)	1.250-18 UNEF-2A	1.220/1.214 (31.0/30.8)	1.229 (31.2)	1.260 (32.0)	-116
20	1.860 (47.2)	1.766 (44.9)	1.243 (31.6)	1.132/1.125 (28.8/28.6)	.985 (25.0)	1.256/1.251 (31.9/31.8)	1.312 (33.3)	1.375-18 UNEF-2A	1.345/1.339 (34.2/34.0)	1.354 (34.4)	1.385 (35.2)	-117
22	2.068 (52.5)	1.954 (49.6)	1.305 (33.1)	1.257/1.252 (31.9/31.8)	1.110 (28.2)	1.381/1.376 (35.1/35.0)	1.437 (36.5)	1.500-18 UNEF-2A	1.470/1.464 (37.3/37.2)	1.479 (37.6)	1.510 (38.4)	-120
24	2.160 (54.9)	2.079 (52.8)	1.493 (37.9)	1.382/1.377 (35.1/35.0)	1.235 (31.4)	1.506/1.501 (38.3/38.1)	1.562 (39.7)	1.625-18 UNEF-2A	1.595/1.587 (40.5/40.3)	1.604 (40.7)	1.635 (41.5)	-121



**230-028**  
**MIL-DTL-83723/88 Series III Type Hermetic  
 Threaded Coupling Square Flange Mount Receptacle  
 with Solder Cup Terminations**

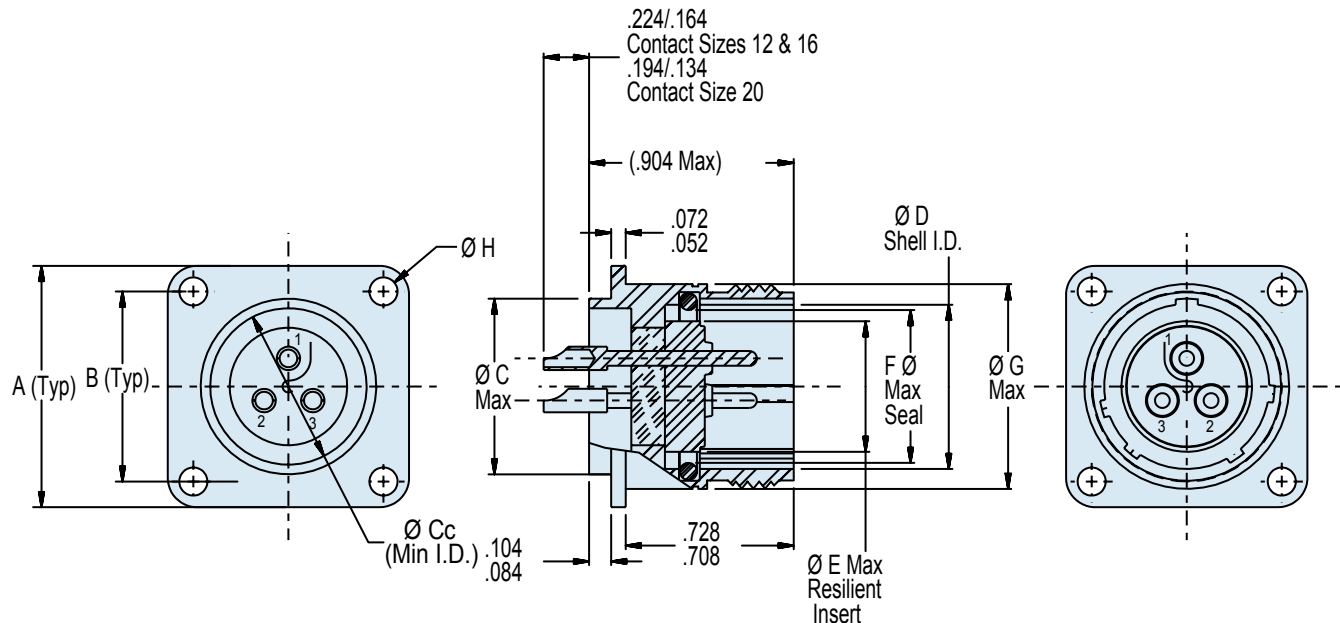
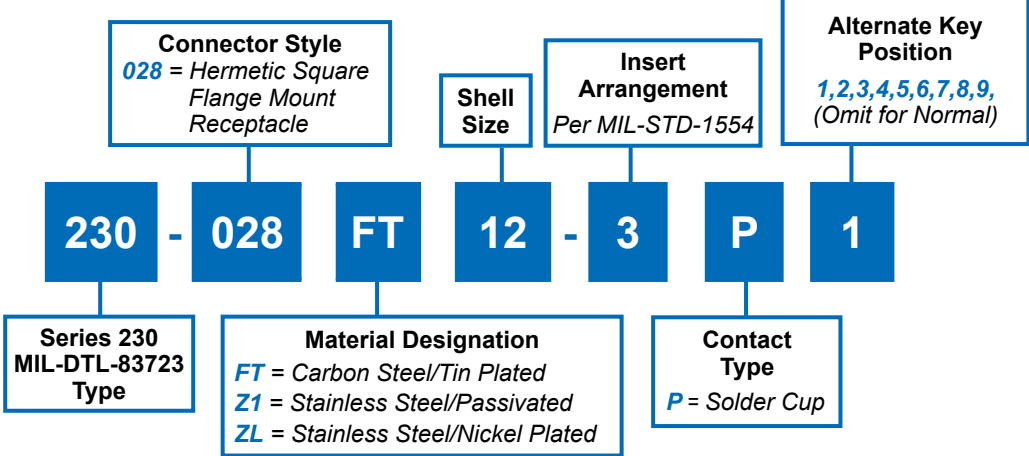

**APPLICATION NOTES**

- To be identified with manufacturer's name, part number and date code, space permitting.
- Material/Finish:  
 Shell\* and Jam-Nut:  
 Z1 - Stainless steel/passivated.  
 FT - Carbon steel/tin plated.  
 ZL - Stainless steel/nickel plated.  
 Contacts - 52 Nickel alloy/gold plated.  
 Seals - Silicone elastomer/N.A.  
 Insulation - Glass/N.A.
- Glenair 230-028 will mate with any QPL MIL-DTL-83723/86, /91, /95 and /97 Series III bayonet coupling plug of same size, keyway, and insert polarization.
- Performance:  
 Hermeticity <math>1 \times 10^{-7}</math> cc He/sec @ 1 atmosphere differential.  
 Dielectric withstanding voltage - Consult factory or MIL-STD-1554.  
 Insulation resistance - 5000 MegOhms min @ 500VDC.
- Consult factory and/or MIL-STD-1554 for arrangement, keyway, and insert position options.
- Metric Dimensions (mm) are indicated in parentheses.

\* Additional shell materials available, including titanium and Inconel®. Consult factory for ordering information.

230-028

MIL-DTL-83723/88 Series III Type Hermetic  
Threaded Coupling Square Flange Mount Receptacle  
with Solder Cup Terminations



MIL-DTL-83723  
Type

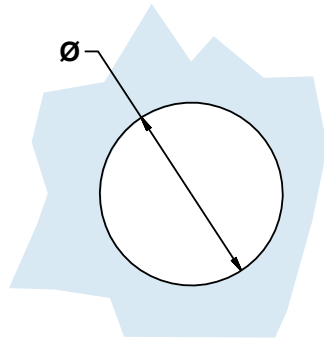

Panel Cut Out

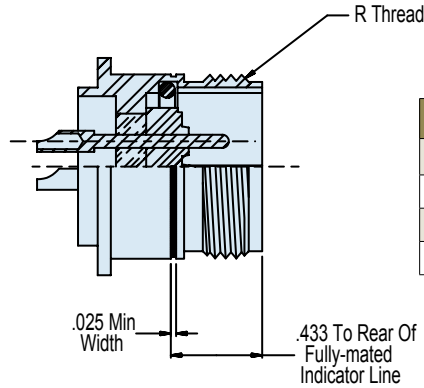

HERMETIC LEAK RATE MOD CODES	
Designator	Required Leak Rate
-585A	1 x 10 <sup>-10</sup> cc Helium per second
-585B	1 x 10 <sup>-9</sup> cc Helium per second
-585C	1 x 10 <sup>-8</sup> cc Helium per second

E

TABLE I: CONNECTOR AND CUT-OUT DIMENSIONS

Shell Size	A	B	C Dia	D Dia Shell I.D.	E Dia Resilient Insert	F Dia Max Seal	G Dia Max	H Dia Thru 4 PI	CC Dia Min	R Coupling Thread UNEF-2A	Panel Cut-Out
8	.812 (20.6)	.594 (15.1)	.500/.494 (12.7/12.5)	.418/.413 (10.6/10.5)	.290 (7.4)	.394 (10.0)	.562 (14.3)	.125/.116 (3.2/2.9)	.400 (10.2)	.562-24	.572 (14.5)
10	.937 (23.8)	.719 (18.3)	.562/.556 (14.3/14.1)	.535/.530 (13.6/13.5)	.388 (9.9)	.515 (13.1)	.696 (17.7)	.125/.116 (3.2/2.9)	.411 (10.4)	.688-24	.706 (17.9)
12	1.031 (26.2)	.812 (20.6)	.750/.744 (19.1/18.9)	.705/.700 (17.9/17.8)	.558 (14.2)	.685 (17.4)	.875 (22.2)	.125/.116 (3.2/2.9)	.581 (14.8)	.875-20	.885 (22.5)
14	1.125 (28.6)	.906 (23.0)	.812/.806 (20.6/20.5)	.774/.769 (19.7/19.5)	.627 (15.9)	.754 (19.2)	.936 (23.8)	.125/.116 (3.2/2.9)	.650 (16.5)	.938-20	.946 (24.0)
16	1.250 (31.8)	.969 (24.6)	.937/.931 (23.8/23.6)	.901/.896 (22.9/22.8)	.772 (19.6)	.881 (22.4)	1.062 (27.0)	.125/.116 (3.2/2.9)	.777 (19.8)	1.062-18	1.072 (27.2)
18	1.343 (34.1)	1.062 (27.0)	1.062/1.056 (27.0/26.8)	1.007/1.002 (25.6/25.5)	.860 (21.8)	.987 (25.1)	1.187 (30.1)	.125/.116 (3.2/2.9)	.864 (21.9)	1.188-18	1.197 (30.4)
20	1.437 (36.5)	1.156 (29.4)	1.187/1.181 (30.1/30.0)	1.132/1.125 (28.8/28.6)	.985 (25.0)	1.112 (28.2)	1.312 (33.3)	.125/.116 (3.2/2.9)	1.034 (26.3)	1.312-18	1.322 (33.6)
22	1.562 (39.7)	1.250 (31.8)	1.312/1.306 (33.3/33.2)	1.257/1.252 (31.9/31.8)	1.110 (28.2)	1.237 (31.4)	1.437 (36.5)	.125/.116 (3.2/2.9)	1.133 (28.8)	1.438-18	1.447 (36.8)
24	1.703 (43.3)	1.375 (34.9)	1.437/1.431 (36.5/36.3)	1.382/1.377 (35.1/35.0)	1.235 (31.4)	1.362 (34.6)	1.562 (39.7)	.154/.145 (3.9/3.7)	1.284 (32.6)	1.562-18	1.572 (39.9)

## MIL-DTL-83723/89 Series III Type Hermetic Threaded Coupling Jam-Nut Mount Receptacle with Solder Cup Terminations

E

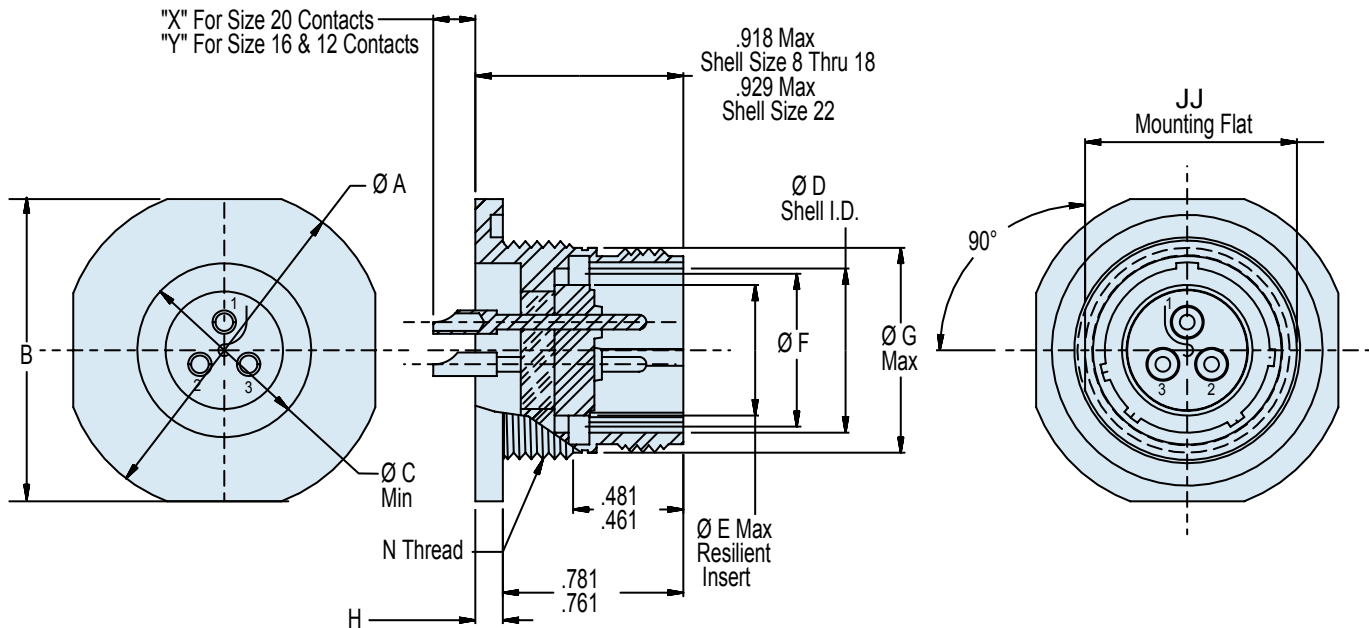
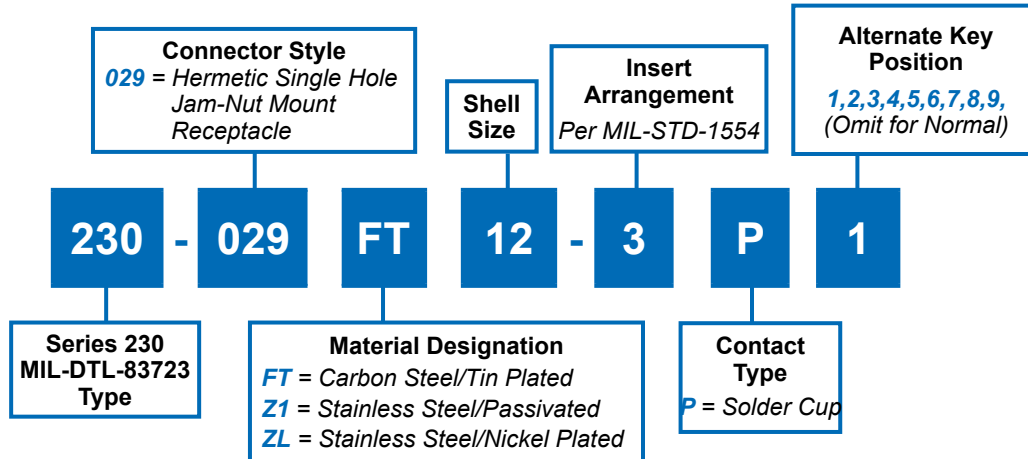

### APPLICATION NOTES

- To be identified with manufacturer's name, part number and date code, space permitting.
- Material/Finish:  
Shell\* and Jam-Nut:  
Z1 - Stainless steel/passivated.  
FT - Carbon steel/tin plated.  
ZL - Stainless steel/nickel plated.  
Contacts - 52 Nickel alloy/gold plated.  
Seals - Silicone elastomer/N.A.  
Insulation - Glass/N.A.
- Glenair 230-029 will mate with any QPL MIL-DTL-83723/86, /91, /95 and /97 Series III bayonet coupling plug of same size, keyway, and insert polarization.
- Performance:  
Hermeticity <math>< 1 \times 10^{-7}</math> cc He/sec @ 1 atmosphere differential.  
Dielectric withstanding voltage - Consult factory or MIL-STD-1554.  
Insulation resistance - 5000 MegOhms min @ 500VDC.
- Consult factory and/or MIL-STD-1554 for arrangement, keyway, and insert position options.
- Metric Dimensions (mm) are indicated in parentheses.

\* Additional shell materials available, including titanium and Inconel®. Consult factory for ordering information.

230-029

MIL-DTL-83723/89 Series III Type Hermetic  
Threaded Coupling Jam-Nut Mount Receptacle  
with Solder Cup Terminations



MIL-DTL-83723  
Type

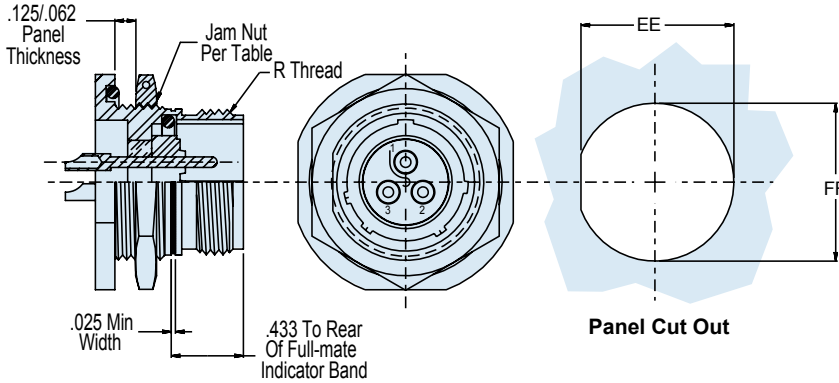

HERMETIC LEAK RATE MOD CODES	
Designator	Required Leak Rate
-585A	1 x 10 <sup>-10</sup> cc Helium per second
-585B	1 x 10 <sup>-9</sup> cc Helium per second
-585C	1 x 10 <sup>-8</sup> cc Helium per second

E

TABLE I: CONNECTOR AND CUT-OUT DIMENSIONS (Continued Below)								
Shell Size	A Dia Max	B	C Dia Min	D Dia Shell I.D.	E Dia Resilient Insert	F Dia Max Seal	G Dia Max	H Flange Thickness
8	1.078/1.047 (27.4/26.6)	.980/.949 (24.9/24.1)	.400 (10.2)	.418/.413 (10.6/10.5)	.290 (7.4)	.394 (10.0)	.562 (14.3)	.137/.097 (3.5/2.5)
10	1.192/1.162 (30.3/29.5)	1.104/1.073 (28.0/27.3)	.411 (10.4)	.535/.530 (13.6/13.5)	.388 (9.9)	.515 (13.1)	.696 (17.7)	.137/.097 (3.5/2.5)
12	1.380/1.349 (35.1/34.3)	1.291/1.260 (32.8/32.0)	.581 (14.8)	.705/.700 (17.9/17.8)	.558 (14.2)	.685 (17.4)	.875 (22.2)	.137/.097 (3.5/2.5)
14	1.516/1.485 (38.5/37.7)	1.391/1.360 (35.3/34.5)	.650 (16.5)	.774/.769 (19.7/19.5)	.627 (15.9)	.754 (19.2)	.936 (23.9)	.137/.097 (3.5/2.5)
16	1.641/1.610 (41.7/40.9)	1.516/1.485 (38.5/37.7)	.777 (19.7)	.901/.896 (22.9/22.8)	.772 (19.6)	.881 (22.4)	1.062 (27.0)	.137/.097 (3.5/2.5)
18	1.766/1.735 (44.9/44.1)	1.641/1.610 (41.7/40.9)	.864 (21.9)	1.007/1.002 (25.6/25.5)	.860 (21.8)	.987 (25.1)	1.187 (30.1)	.137/.097 (3.5/2.5)
22	2.078/2.047 (52.8/52.0)	1.954/1.923 (49.6/48.8)	1.133 (28.8)	1.257/1.252 (31.9/31.8)	1.110 (28.2)	1.237 (31.4)	1.437 (36.5)	.148/.128 (3.8/3.3)

TABLE I: CONNECTOR AND CUT-OUT DIMENSIONS (Continued From Above)								
Shell Size	N Thread	R Thread	JJ Mounting Flat	Panel Cut-Out EE +.000 -.002 (.05)	Panel Cut-Out FF DIA ±.005 (0.1)	Jam Nut MS3186	X	Y
8	.625-20 UN-2A	.562-24 UNEF-2A	.596/.590 (15.1/15.0)	.605 (15.4)	.635 (16.1)	-105	.180/.120 (4.6/3.0)	.210/.150 (5.3/3.8)
10	.750-20 UNEF-2A	.688-24 UNEF-2A	.721/.715 (18.3/18.2)	.730 (18.5)	.760 (19.3)	-107	.180/.120 (4.6/3.0)	.210/.150 (5.3/3.8)
12	.937-20 UNEF-2A	.875-20 UNEF-2A	.908/.902 (23.1/22.9)	.917 (23.3)	.947 (24.1)	-110	.180/.120 (4.6/3.0)	.210/.150 (5.3/3.8)
14	1.000-20 UNEF-2A	.938-20 UNEF-2A	.971/.965 (24.7/24.5)	.980 (24.9)	1.010 (25.7)	-111	.180/.120 (4.6/3.0)	.210/.150 (5.3/3.8)
16	1.125-20 UNEF-2A	1.062-18 UNEF-2A	1.096/1.090 (27.8/27.7)	1.105 (28.1)	1.135 (32.1)	-112	.180/.120 (4.6/3.0)	.210/.150 (5.3/3.8)
18	1.250-18 UNEF-2A	1.188-18 UNEF-2A	1.220/1.214 (31.0/30.8)	1.230 (31.2)	1.260 (32.0)	-116	.180/.120 (4.6/3.0)	.210/.150 (5.3/3.8)
22	1.500-18 UNEF-2A	1.438-18 UNEF-2A	1.470/1.464 (37.3/37.2)	1.480 (37.6)	1.510 (38.4)	-120	.169/.109 (4.3/2.8)	.199/.139 (5.1/3.5)



**230-030**  
**MIL-DTL-83723/90 Series III Type Hermetic  
 Threaded Coupling Solder Flange Mount Receptacle  
 with Solder Cup Terminations**

**E**

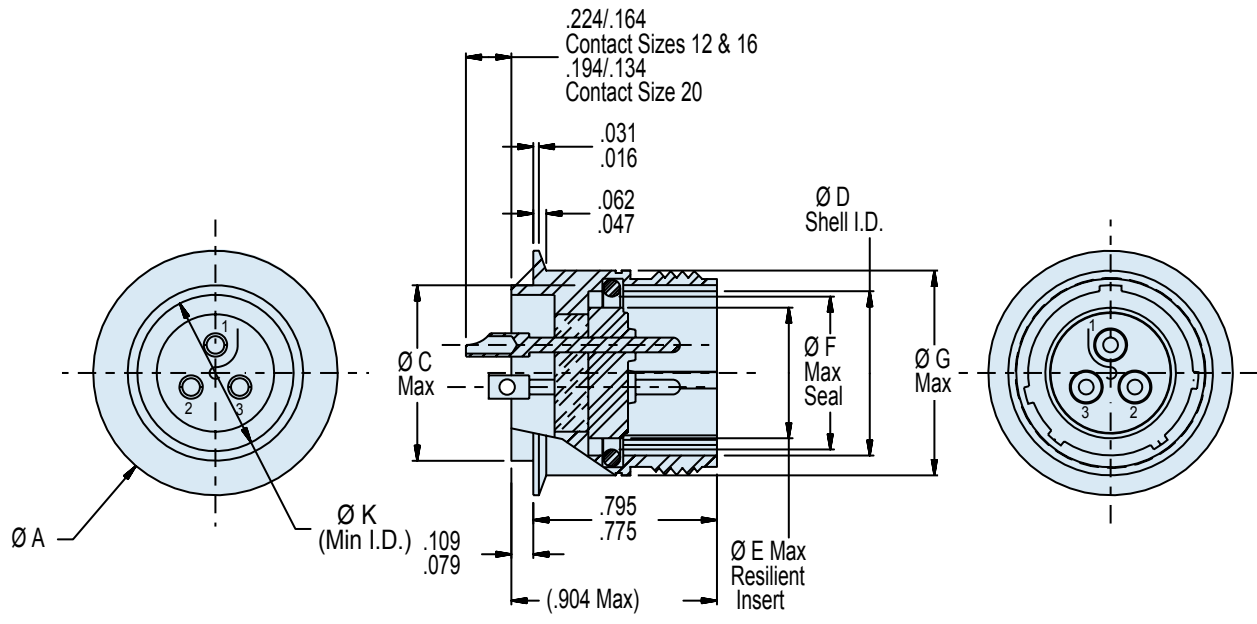
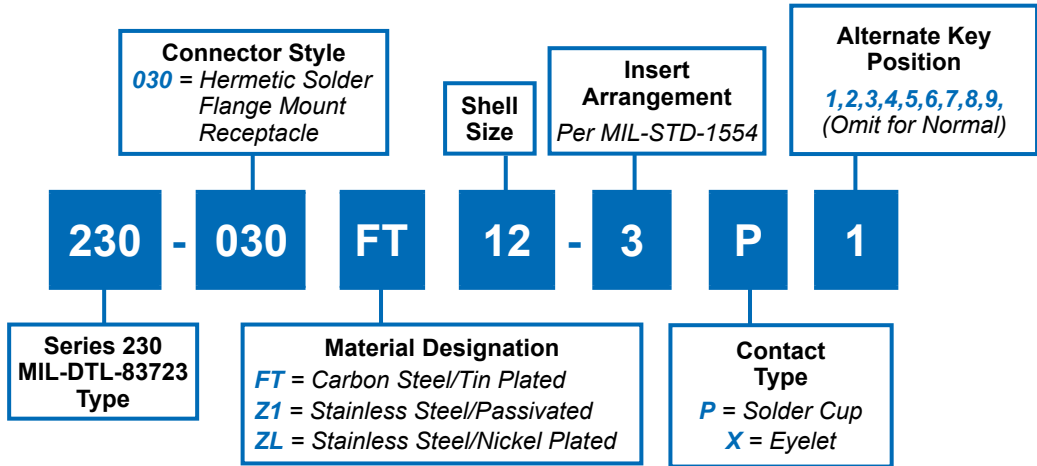

**APPLICATION NOTES**

- |  |  |
|--|--|
| <ol style="list-style-type: none"> <li>1. To be identified with manufacturer's name, part number and date code, space permitting.</li> <li>2. Material/Finish:<br/>                     Shell* and Jam-Nut:<br/>                         Z1 - Stainless steel/passivated.<br/>                         FT - Carbon steel/tin plated.<br/>                         ZL - Stainless steel/nickel plated.<br/>                     Contacts - 52 Nickel alloy/gold plated.<br/>                     Seals - Silicone elastomer/N.A.<br/>                     Insulation - Glass/N.A.</li> <li>3. Glenair 230-030 will mate with any QPL MIL-DTL-83723/86, /91, /95 and /97 Series III threaded coupling plug of same size, keyway, and insert polarization.</li> </ol> | <ol style="list-style-type: none"> <li>4. Performance:<br/>                     Hermeticity &lt;1 x 10<sup>-7</sup> cc He/sec @ 1 atmosphere differential.<br/>                     Dielectric withstanding voltage - Consult factory or MIL-STD-1554.<br/>                     Insulation resistance - 5000 MegOhms min @ 500VDC.</li> <li>5. Consult factory and/or MIL-STD-1554 for arrangement, keyway, and insert position options.</li> <li>6. Metric Dimensions (mm) are indicated in parentheses.</li> </ol> |
|--|--|

\* Additional shell materials available, including titanium and Inconel®. Consult factory for ordering information.

230-030

MIL-DTL-83723/90 Series III Type Hermetic  
Threaded Coupling Solder Flange Mount Receptacle  
with Solder Cup Terminations



MIL-DTL-83723  
Type

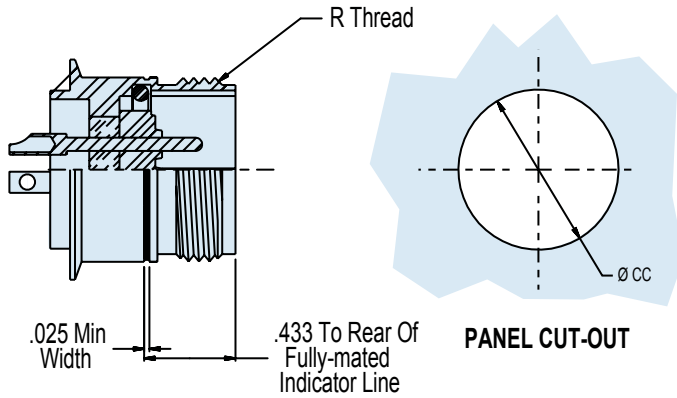

HERMETIC LEAK RATE MOD CODES	
Designator	Required Leak Rate
-585A	1 x 10 <sup>-10</sup> cc Helium per second
-585B	1 x 10 <sup>-9</sup> cc Helium per second
-585C	1 x 10 <sup>-8</sup> cc Helium per second

E

TABLE I: CONNECTOR AND CUT-OUT DIMENSIONS									
Shell Size	A Dia	C Dia	D Dia Shell I.D.	E Dia Resilient Insert	F Dia Max Seal	G Dia Max	K Dia Min	Ø CC Panel Cut-Out	R Coupling Thread
8	.723/.703 (18.4/17.9)	.500/.494 (12.7/12.5)	.418/.413 (10.6/10.5)	.290 (7.4)	.394 (10.0)	.562 (14.3)	.400 (10.2)	.515/.505 (13.1/12.8)	.562-24 UNEF-2A
10	.850/.830 (21.6/21.1)	.562/.556 (14.3/14.1)	.535/.530 (13.6/13.5)	.388 (9.9)	.515 (13.1)	.696 (17.7)	.411 (10.4)	.577/.567 (14.7/14.4)	.688-24 UNEF-2A
12	1.055/1.035 (26.8/26.3)	.750/.744 (19.1/18.9)	.705/.700 (17.9/17.8)	.558 (14.2)	.685 (17.4)	.875 (22.2)	.581 (14.8)	.765/.755 (19.3/19.2)	.875-20 UNEF-2A
14	1.100/1.080 (27.9/27.4)	.812/.806 (20.6/20.5)	.774/.769 (19.7/19.5)	.627 (15.9)	.754 (19.2)	.936 (23.8)	.650 (16.5)	.827/.817 (21.0/20.8)	.938-20 UNEF-2A
16	1.220/1.200 (31.0/30.5)	.937/.931 (23.8/23.6)	.901/.896 (22.9/22.8)	.772 (19.6)	.881 (22.4)	1.062 (27.0)	.777 (19.7)	.952/.942 (24.2/23.9)	1.062-18 UNEF-2A
18	1.350/1.330 (34.3/33.8)	1.062/1.056 (27.0/26.8)	1.007/1.002 (25.6/25.5)	.860 (21.8)	.987 (25.1)	1.187 (30.1)	.864 (21.9)	1.077/1.067 (27.4/27.1)	1.188-18 UNEF-2A
22	1.600/1.580 (40.6/40.1)	1.312/1.306 (36.5/33.2)	1.257/1.252 (31.9/31.8)	1.110 (28.2)	1.237 (31.4)	1.437 (36.5)	1.133 (28.8)	1.327/1.317 (33.7/33.5)	1.438-18 UNEF-2A



BAYONET AND  
THREADED

# MIL-DTL-26500

*Type Glass Seal  
Hermetic Connectors*



The MIL-DTL-26500 type connector is ideally suited for use on commercial, military and aerospace interconnect systems that demand hermetic sealing and high vibration resistance in a medium density cylindrical connector. Thirty-four insert arrangements are available in both threaded and bayonet coupling styles for a wide range of applications. Glenair makes all its hermetic connectors in-house from design to finished product, affording you outstanding availability on stock products and fast turnaround on special orders.

GLASS-SEALED  
**Hermetic**  
CONNECTORS

**Glenair**<sup>®</sup>

Glenair, Inc.  
1211 Air Way  
Glendale, CA  
91201-2497  
818-247-6000  
sales@glenair.com  
www.glenair.com

**Selected MIL-DTL-26500 Type Glass Sealed Hermetic Receptacles—Popular Connector Designs Superseded by MIL-DTL-83723**

Glenair MIL-DTL-26500 Hermetic connectors are offered in either passivated stainless steel or fused tin over stainless steel, with glass insulators fused to the connector shell, and contacts meeting a leak rate of  $1 \times 10^{-7}$  cc/helium per second. Maximum design flexibility is built into the MIL-DTL-26500 hermetic connector— with a minimum of 2 to a maximum of 61 circuits per connector in a wide variety of contact arrangements IAW MIL-STD-1554.

Fluorosilicone elastomer interfacial and peripheral seals ensure positive sealing with plug connectors. Nickel-iron alloy 52 contacts—available in sizes 12, 16 and 20— depending on the layout chosen—offer a broad selection of insert arrangement options. Optional solder cup or eyelet contact terminations are standard. Contacts for other applications such as thermocouple or flex prints are also available.

Quick Selection Guide		
Part Number	Description	Page
	MIL-DTL-26500 Type Insert Arrangements	F-2
	MIL-DTL-26500 Type Insert Arrangements and Keyway Positions	F-3
	Glenair Hermetic Connector Products Special Leak Rate Mod Codes	F-4
	Glenair Hermetic Connector Products Space Grade Mod Codes	F-5
	MIL-DTL-26500 Type Materials and Finishes	F-6
	MIL-DTL-26500 Type Bayonet and Threaded Coupling and Electrical Service Data	F-7
<b>230-036</b> <b>MS27034H*B**</b>	MIL-DTL-26500 Type Bayonet Coupling Solder Flange Mount Receptacle	F-8
<b>230-038</b> <b>MS27034H*T**</b>	MIL-DTL-26500 Type Threaded Coupling Solder Flange Mount Receptacle	F-10
<b>230-039</b> <b>MS24265*B**</b>	MIL-DTL-26500 Type Bayonet Coupling Single Hole Mount Receptacle	F-12
<b>230-040</b> <b>MS24265H*T**</b>	MIL-DTL-26500 Type Threaded Coupling Single Hole Mount Receptacle	F-14
<b>230-041</b> <b>MS24264H*B**</b>	MIL-DTL-26500 Type Bayonet Coupling Square Flange Mount Receptacle	F-16
<b>237-165</b>	MIL-DTL-26500 Type Threaded Coupling Square Flange Mount Receptacle	F-18

**F**

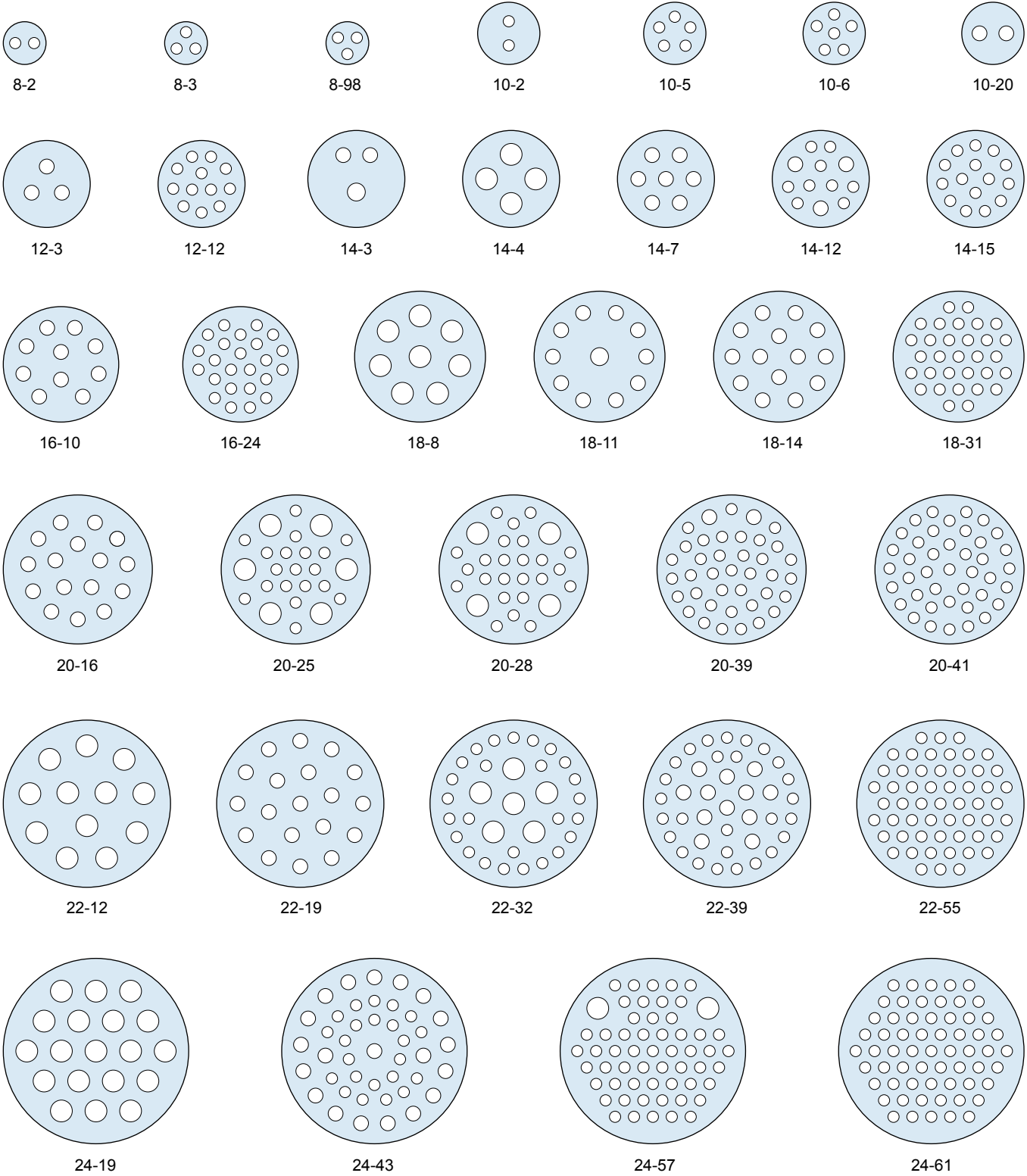

Dimensions in Inches (millimeters) are subject to change without notice.

# MIL-DTL-26500 Type Hermetic Class Connectors Threaded and Bayonet Coupling Insert Arrangements and Keyway Positions (IAW MIL-STD-1554)



MIL-DTL-26500  
Type

F

Insert Arrangements					
Shell Size Designator	Insert Arrangement Dash Number	Service Rating	Contact Size and Quantity		
			20	16	12
08	08-02	I	2		
	08-03	I	3		
	08-98	I	3		
10	10-02	I	2		
	10-05	I	5		
	10-06	I	6		
	10-20	I		2	
12	12-03	I		3	
	12-12	I	12		
14	14-03*	I		3*	
	14-04	I			4
	14-07	I		7	
	14-12	I	9	3	
	14-15	I	15		
16	16-10	I		10	
	16-24	I	24		
18	18-08	I			8
	18-11*	I		11*	
	18-14	I		14	
	18-31	I	31		
20	20-16	I		16	
	20-25	I	19		6
	20-28	I	24		4
	20-39	I	37	2	
	20-41	I	41		
22	22-12	I			12
	22-19	I		19	
	22-32	I	26		6
	22-39	I	27	12	
	22-55	I	55		
24	24-19	I			19
	24-43	I	23	20	
	24-57	I	55		2
	24-61	I	61		

\*1 shielded.

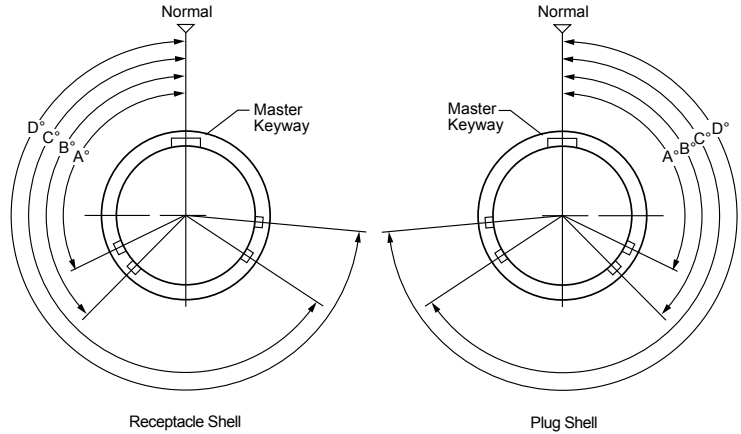

Keyway Positions (Front Face of Pin Insert)					
Shell Size	Keyway Position	A°	B°	C°	D°
08 through 10	Normal	105°	140°	215°	265°
	6	102°	132°	248°	320°
	7	80°	118°	230°	312°
	8	35°	140°	205°	275°
	9	64°	155°	234°	304°
	Y or 10	25°	115°	220°	270°
12 through 24	Normal	105°	140°	215°	265°
	6	18°	149°	192°	259°
	7	92°	152°	222°	342°
	8	84°	152°	204°	334°
	9	24°	135°	199°	240°
	Y or 10	98°	152°	268°	338°

Y Position not available for shell size 8.  
Use "Y" when ordering military parts, "10" when ordering commercial parts

Dimensions in Inches (millimeters) are subject to change without notice.

### Leak Rate Designator

**B** – (See Table Below)

**– 585 B**

### Mod Code

**585** – Increased Hermeticity Mod Code

### What is the –585 Mod Code?

Glenair offers an array of hermetic connectors with more stringent leak rate requirements. By adding “–585” and the designator letter “A”, “B” or “C”—depending on the hermeticity desired—to the end of a standard part number, connectors will be built to exceed the standard  $1 \times 10^{-7}$  cc Helium per second leak rate specified on most Glenair hermetics.

### HERMETIC LEAK RATE MOD CODES

Designator	Required Leak Rate
<b>A</b>	$1 \times 10^{-10}$ cc's Helium per second
<b>B</b>	$1 \times 10^{-9}$ cc's Helium per second
<b>C</b>	$1 \times 10^{-8}$ cc's Helium per second

### Catalog Notes

For all parts in this catalog:

- All parts will be identified with manufacturer's name and part number, space permitting.
- Glenair 600 series backshell assembly tools are recommended for assembly and installation.
- Dimensions are subject to change without notice. Metric dimensions appear in parentheses in diagrams and tables, based on 1 inch = 25.4 mm, for reference only. Unless otherwise specified, the following other dimensional tolerances apply:

.xx = ± .03 (0.8)      Lengths = ± .060 (1.52)  
.xxx = ± .015 (0.4)      Angles = ± 5°

Customers are advised to consult the factory for the latest specifications, particularly to confirm critical dimensions such as connector lengths, threads, and so on. When errors or mistakes are brought to our attention, corrected content is posted immediately to [www.glenair.com](http://www.glenair.com).

Dimensions in Inches (millimeters) are subject to change without notice.

### What is outgassing?

Plastic and rubber materials give off gaseous molecules. For example, the smell inside a new car is caused by polymer outgassing. Heat and vacuum increase the rate of diffusion. In a spacecraft the gases coming off polymers can contaminate optical surfaces and instruments. The result is degraded performance.

### How is outgassing measured?

The space industry has adopted a standardized test procedure, **ASTM E 595**, to evaluate out-gassing properties of polymers. Small samples of material are heated to 125° C. at a vacuum of  $5 \times 10^{-5}$  torr for 24 hours. Then the sample is weighed to calculate the **Total Mass Loss** (TML). The TML cannot exceed 1.00% of the total initial mass. During the test, outgassed matter condenses on a cooled collector plate. The quantity of outgassed matter is calculated to determine the **Collected Volatile Condensable Material** (CVCN). The CVCN cannot exceed 0.10% of the original specimen mass.

### What is NASA screening?

NASA specification EEE-INST-002 provides instructions on selecting, screening and qualifying parts for use on NASA GSFC space flight projects.

### What screening level is required?

NASA defines three levels of screening: level 1 for highest reliability, level 2 for high reliability, and level 3 for standard reliability. Level 3 equates to standard lot acceptance inspection. Levels 1 and 2 call for additional testing.

## HOW TO ORDER SPACE GRADE CONNECTORS

### Step 1: Find a Standard Part Number

Electroless nickel plated shells are preferred for space flight. Cadmium plating is prohibited.

### Step 2: Select a NASA Screening Level

The term "Screening Level" refers to the final inspection procedure.

**Level 1** for mission-critical highest reliability

**Level 2** for high reliability

**Level 3** for standard reliability

### Step 3: Choose Outgassing Processing

A detailed explanation of outgassing is on the following pages. The fluorosilicone rubber seals commonly used on aerospace-grade connectors such as MIL-DTL-38999 and Series 79 connectors, along with certain bonding agents and inks, do not meet NASA outgassing requirements unless the connector is specially processed. Glenair outgassing tests have shown oven baking or thermal vacuum outgassing processing are sufficient to reduce outgassing levels to NASA standards. Oven baking is more economical than thermal vacuum outgassing.

### Step 4: Select the Mod 429 Code that Matches the Desired Level of Screening and Outgassing

Use the following table to choose the right modification code. Add the mod code to the connector part number. Example: 790-024PC-13ML-**429C**

## NASA SCREENING LEVELS AND MODIFICATION CODES

NASA Screening Level	Special Screening Only	Special Screening Plus Outgassing Processing	
		8 Hour Oven Bake 400° F.	Thermal Vacuum Outgassing 24 hrs. 125° C.
Level 1 Highest Reliability	Mod 429B	Mod 429J	Mod 429C
Level 2 High Reliability	Mod 429	Mod 429K	Mod 429A
Level 3 Standard Reliability	(Use standard part number)	Mod 186	Mod 186M

Dimensions in Inches (millimeters) are subject to change without notice.

**TABLE I: HERMETIC CLASS MATERIALS**

<b>Shell, Barrel Coupling Nut and Jam Nut (Hermetic)</b>	Cold rolled steel per ASTM 108
<b>Interfacial Seals and O-Rings</b>	Fluorosilicone rubber
<b>Contacts</b>	Nickel-iron alloy per MIL-I-23011, Class 2
<b>Bayonet Pins</b>	Corrosion resistant steel per QQ-S-764, Type 303
<b>Inserts</b>	Glass

**TABLE II: HERMETIC CLASS FINISHES**

<b>Plating Code</b>	<b>Material</b>	<b>Finish</b>	<b>Specification</b>
<b>Glenair Commercial Equivalent Plating Codes</b>			
<b>Z1</b>	Stainless Steel	Passivate	AMS-QQ-P-35
<b>FT</b>	Carbon Steel	Fused Tin Plate	ASTM-B545 or ASTM-B339
<b>SM</b>	Carbon Steel	Electroless Nickel	
<b>ZL</b>	Stainless Steel	Electrodeposited Nickel	SAE-AMS-QQ-N-290, Class 2
<b>MIL-DTL-26500 Plating Codes</b>			
<b>D</b>	Cold Rolled Steel	Fused Tin over Copper over Nickel	MIL-T-10727, MIL-C-14550, QQ-N-290
<b>E</b>	Stainless Steel	Passivate	QQ-S-764, Type 303
<b>N</b>	Stainless Steel	Electrodeposited Nickel	SAE-AMS-QQ-N-290, Class 2

\*Additional materials are available, including titanium and Inconel®. Consult factory for ordering information.

Dimensions in Inches (millimeters) are subject to change without notice.



**MIL-DTL-26500 Type  
Hermetic Class Connectors  
Bayonet and Thread Coupling and Electrical Service Data**



**BAYONET COUPLING**

Description	Military Designation	Glenair Designation
<b>Jam Nut Mount</b>	MS24265H*B*CN MS24265H*B*EN	230-039 230-039
<b>Solder Mount</b>	MS247034H*B*CN MS27034H*B*EN	230-036 230-036
<b>Square Flange</b>	MS24264H*B*CN MS24264H*B*EN	230-041 230-041
<b>Mating Plug</b>	MS24266R*B*SN	

**THREAD COUPLING**

Description	Military Designation	Glenair Designation
<b>Jam Nut Mount</b>	MS24265H*T*CN MS24265H*T*EN	230-040 230-040
<b>Solder Mount</b>	MS27034H*T*CN MS27034H*T*EN	230-038 230-038
<b>Square Flange</b>	MS24264H*T*CN MS24264H*T*EN	237-165 237-165
<b>Mating Plug</b>	MS24266R*T*SN	

Based on contact size, the maximum current carried by the connector is the same permitted by the wire bundle. Maximum current ratings and voltage drops demonstrated in tests of fully assembled connectors are shown in the following table:

**ELECTRICAL SERVICE DATA**

Contact Size	Test Current (Amps)	Potential Drop (Millivolts)
<b>20</b>	5	100
<b>16</b>	10	95
<b>12</b>	17	95

Method 3001 of MIL-STF-1344 specifying high potential test voltage mandates that tested unmated connectors will not exceed 2 milliamperes in leakage and present no sign of electrical breakdown or flashover per the following table:

**HIGH POTENTIAL TEST VOLTAGE**

Service Rating	Test Voltage (RMS 60 CPS)
<b>1</b>	1500

Dimensions in Inches (millimeters) are subject to change without notice.

**How To Order: Commercial**

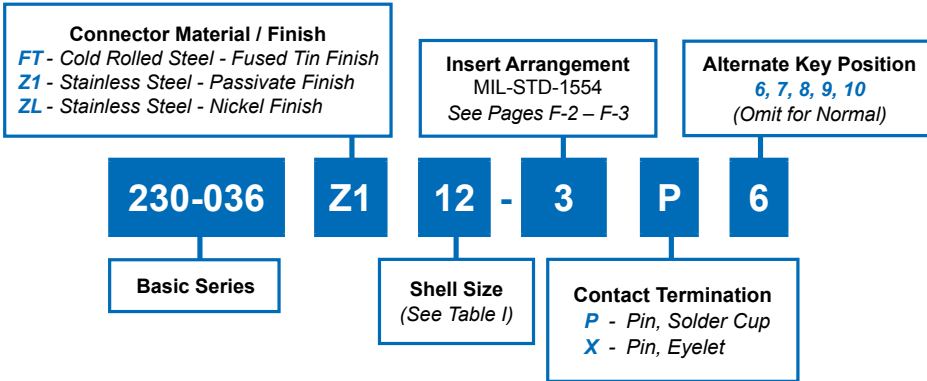

**F**

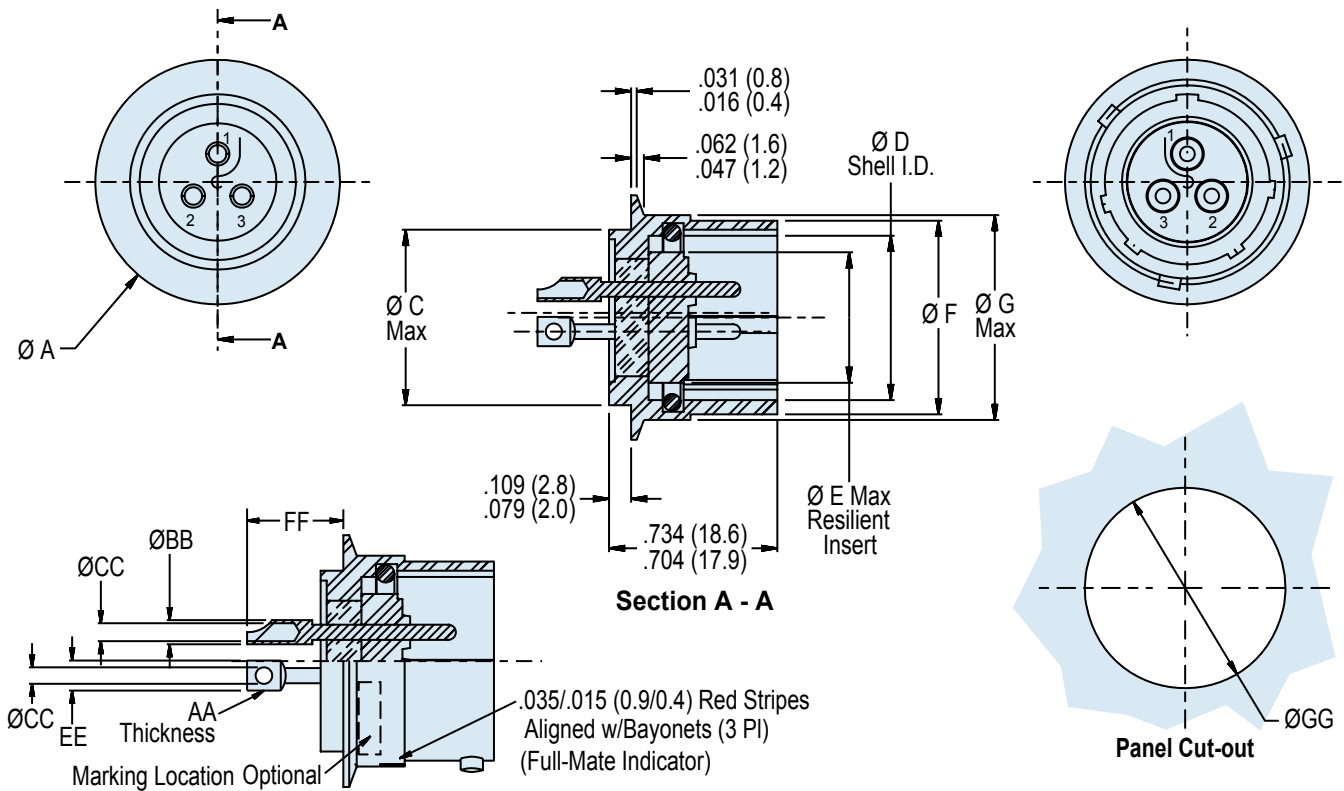

Dimensions in Inches (millimeters) are subject to change without notice.

**230-036**  
**MIL-DTL-26500 Type Hermetic Class Receptacle**  
**MS27034H\*B\*\* Type Solder Flange Mount, Bayonet Coupling**



MIL-DTL-26500  
Type

**F**

**TABLE I: Shell Size, Connector Dimensions and Panel Cut-Out**

Shell Size	Ø A	Ø C Max	Ø D Shell I.D.	Ø E Resilient Insert	Ø F	Ø G Max	Panel Cut-Out Ø GG
8	.725/.685 (18.4/17.4)	.437 (11.1)	.433/.428 (11.0/10.9)	.312 (7.9)	.536/.531 (13.6/13.5)	.561 (14.2)	.452/.442 (11.5/11.2)
10	.860/.820 (21.8/20.8)	.562 (14.3)	.535/.530 (13.6/13.5)	.388 (9.9)	.659/.654 (16.7/16.6)	.696 (17.7)	.577/.567 (14.7/14.4)
12	1.065/1.025 (27.1/26.0)	.750 (19.1)	.705/.700 (17.9/17.8)	.558 (14.2)	.829/.824 (21.1/20.9)	.875 (22.2)	.765/.755 (19.4/19.2)
14	1.110/1.070 (28.2/27.2)	.812 (20.6)	.774/.769 (19.7/19.5)	.627 (15.9)	.898/.893 (22.8/22.7)	.935 (23.7)	.827/.817 (21.0/20.8)
16	1.230/1.190 (31.2/30.2)	.937 (23.8)	.901/.896 (22.9/22.8)	.754 (19.2)	1.025/1.020 (26.0/25.9)	1.062 (27.0)	.952/.942 (24.2/23.9)
18	1.360/1.320 (34.5/33.5)	1.062 (27.0)	1.007/1.002 (25.6/25.5)	.860 (21.8)	1.131/1.126 (28.7/28.6)	1.187 (30.1)	1.077/1.067 (27.4/27.1)
20	1.495/1.455 (38.0/37.0)	1.182 (30.0)	1.132/1.127 (28.8/28.6)	.985 (25.0)	1.256/1.251 (31.9/31.8)	1.312 (33.3)	1.197/1.187 (30.4/30.1)
22	1.610/1.570 (40.9/39.9)	1.312 (33.3)	1.257/1.252 (31.9/31.8)	1.110 (28.2)	1.381/1.376 (35.1/35.0)	1.437 (36.5)	1.327/1.317 (33.7/33.5)
24	1.745/1.705 (44.3/43.3)	1.432 (36.4)	1.382/1.377 (35.1/35.0)	1.235 (31.4)	1.506/1.501 (38.3/38.1)	1.562 (39.7)	1.447/1.437 (36.8/36.5)

**TABLE II: Contacts**

Contact Size	Contact Type	AA	ØØ BB	ØØ CC Min	DD	FF Max
12	Cup	--	.150 (3.8)	.112 (2.8)	.200 (5.1)	.400 (10.2)
12	Eyelet	.035 (0.9)	--	.112 (2.8)	--	.400 (10.2)
16	Cup	--	.103 (2.6)	.069 (1.8)	.125 (3.2)	.400 (10.2)
16	Eyelet	.025 (0.6)	--	.069 (1.8)	--	.400 (10.2)
20	Cup	--	.077 (2.0)	.042 (1.1)	.080 (2.0)	.330 (8.4)
20	Eyelet	.015 (0.4)	--	.042 (1.1)	--	.330 (8.4)

**APPLICATION NOTES**

- |  |   |
|--|---|
| <ol style="list-style-type: none"> <li>Assembly identified with manufacturer's name and part number, space permitting.</li> <li>Glenair 230-036 will mate with any QPL MIL-DTL-26500, MS24266 and MS27615 series bayonet coupling plug of same size, keyway and insert polarization.</li> <li>Performance:<br/>                     Hermeticity - &lt;math&gt; &lt; 10^{-7}&lt;/math&gt; ccHe/sec @ 1 atmosphere differential<br/>                     Dielectric withstanding voltage - consult factory or MIL-STD-1554<br/>                     Insulation resistance - 5000 megohms min @ 500VDC</li> </ol> | <ol style="list-style-type: none"> <li>Material/ Finish:<br/>                     Bayonets—Cres/Passivated<br/>                     Contacts—52 Nickel alloy/Gold plated<br/>                     Insulators—Glass/NA<br/>                     Seals—fluorosilicone elastomer N.A.</li> <li>Metric Dimensions (mm) are indicated in parentheses.</li> </ol> |
|--|---|

Dimensions in Inches (millimeters) are subject to change without notice.

**How To Order: Commercial**
**Connector Material / Finish**

**FT** - Cold Rolled Steel - Fused Tin Finish  
**Z1** - Stainless Steel - Passivate Finish  
**ZL** - Stainless Steel - Nickel Finish

**Insert Arrangement**

MIL-STD-1554  
 See Pages F-2 – F-3

**Alternate Key Position**

**6, 7, 8, 9, 10**  
 (Omit for Normal)

**230-038**
**Z1**
**12**
**3**
**P**
**6**
**Basic Series**
**Shell Size**  
 (See Table I)

**Contact Termination**  
**P** - Pin, Solder Cup  
**X** - Pin, Eyelet

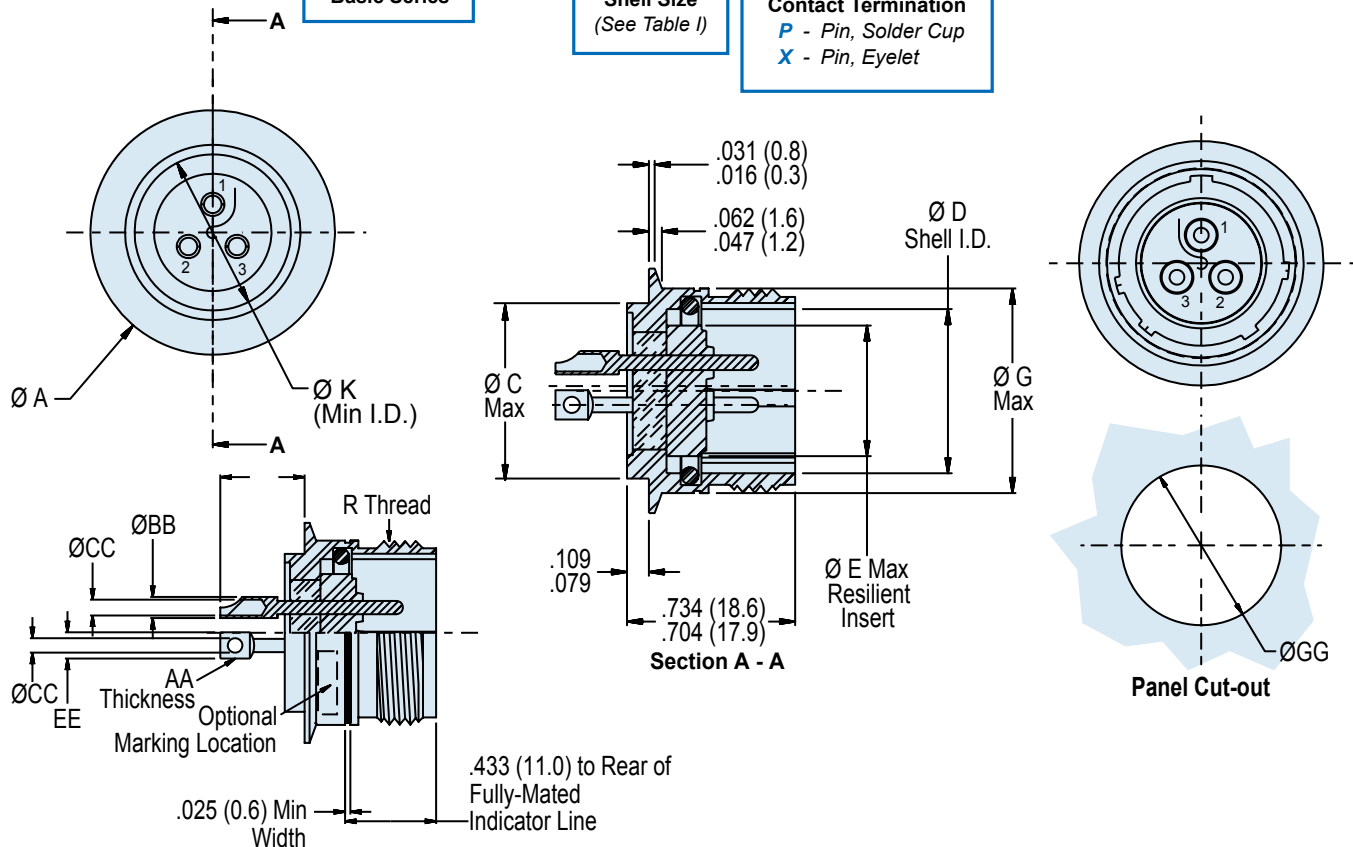
**F**

**APPLICATION NOTES**

- Assembly identified with manufacturer's name and part number, space permitting.
- Glenair 230-038 will mate with any QPL MIL-DTL-26500, MS24266 and MS27615 series threaded coupling plug of same size, keyway and insert polarization.
- Performance:  
 Hermeticity -  $< \times 10^{-7}$  ccHe/sec @ 1 atmosphere differential  
 Dielectric withstanding voltage - consult factory or MIL-STD-1554  
 Insulation resistance - 5000 megohms min @ 500VDC
- Material/ Finish:  
 Contacts—52 Nickel alloy/Gold plated  
 Insulators—Glass/NA  
 Seals—fluorosilicone elastomer N.A.
- Metric Dimensions (mm) are indicated in parentheses.

Dimensions in Inches (millimeters) are subject to change without notice.

230-038

**MIL-DTL-26500 Type Hermetic Class Receptacle**  
**MS27034H\*\*T\*\* Type Solder Flange Mount, Threaded Coupling**

MIL-DTL-26500  
Type**TABLE I: Shell Size, Connector Dimensions and Panel Cut-Out**

Shell Size	Ø A	Ø C Max	Ø D Shell I.D.	Ø E Resilient Insert	Ø G Max	Panel Cut-Out Ø GG	R Coupling Thread UNEF-2A
8	.725/.705 (18.4/17.9)	.437 (11.1)	.433/.428 (11.0/10.9)	.312 (7.9)	.561 (14.2)	.452/.442 (11.5/11.2)	.562-24
10	.860/.840 (21.8/21.3)	.562 (14.3)	.535/.530 (13.6/13.5)	.388 (9.9)	.696 (17.7)	.577/.567 (14.7/14.4)	.687-24
12	1.065/1.045 (27.1/26.5)	.750 (19.1)	.705/.700 (17.9/17.8)	.558 (14.2)	.875 (22.2)	.765/.755 (19.4/19.2)	.875-20
14	1.110/1.090 (28.2/27.7)	.812 (20.6)	.774/.769 (19.7/19.5)	.627 (15.9)	.935 (23.7)	.827/.817 (21.0/20.8)	.937-20
16	1.230/1.210 (31.2/30.7)	.937 (23.8)	.901/.896 (22.9/22.8)	.754 (19.2)	1.062 (27.0)	.957/.942 (24.3/23.9)	1.062-18
18	1.360/1.340 (34.5/34.0)	1.062 (27.0)	1.007/1.002 (25.6/25.5)	.860 (21.8)	1.187 (30.1)	1.077/1.067 (27.4/27.1)	1.187-18
20	1.495/1.475 (38.0/37.5)	1.182 (30.0)	1.132/1.127 (28.8/28.6)	.965 (24.5)	1.312 (33.3)	1.197/1.187 (30.4/30.1)	1.312-18
22	1.610/1.590 (40.9/40.4)	1.312 (33.3)	1.257/1.252 (31.9/31.8)	1.110 (28.2)	1.437 (36.5)	1.327/1.317 (33.7/33.5)	1.437-18
24	1.745/1.725 (44.3/43.8)	1.432 (36.4)	1.382/1.377 (35.1/35.0)	1.235 (31.4)	1.262 (32.1)	1.447/1.437 (36.8/36.5)	1.562-18

F

**TABLE II: Contacts**

Contact Size	Contact Type	AA	ØØ BB	ØØ CC Min	DD	FF Max
12	Cup	--	.150 (3.8)	.112 (2.8)	.200 (5.1)	.400 (10.2)
12	Eyelet	.035 (0.9)	--	.112 (2.8)	--	.400 (10.2)
16	Cup	--	.103 (2.6)	.069 (1.8)	.125 (3.2)	.400 (10.2)
16	Eyelet	.025 (0.6)	--	.069 (1.8)	--	.400 (10.2)
20	Cup	--	.077 (2.0)	.042 (1.1)	.080 (2.0)	.330 (8.4)
20	Eyelet	.015 (0.4)	--	.042 (1.1)	--	.330 (8.4)

Dimensions in Inches (millimeters) are subject to change without notice.

© 2013 Glenair, Inc.

U.S. CAGE Code 06324

Printed in U.S.A.

**How To Order: Commercial**

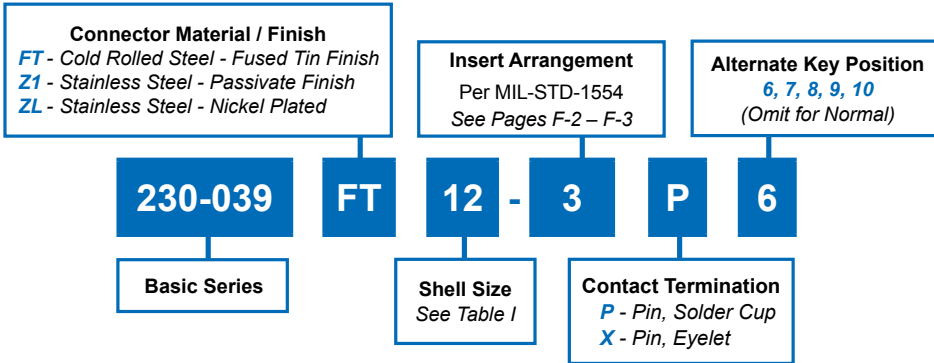

**F**

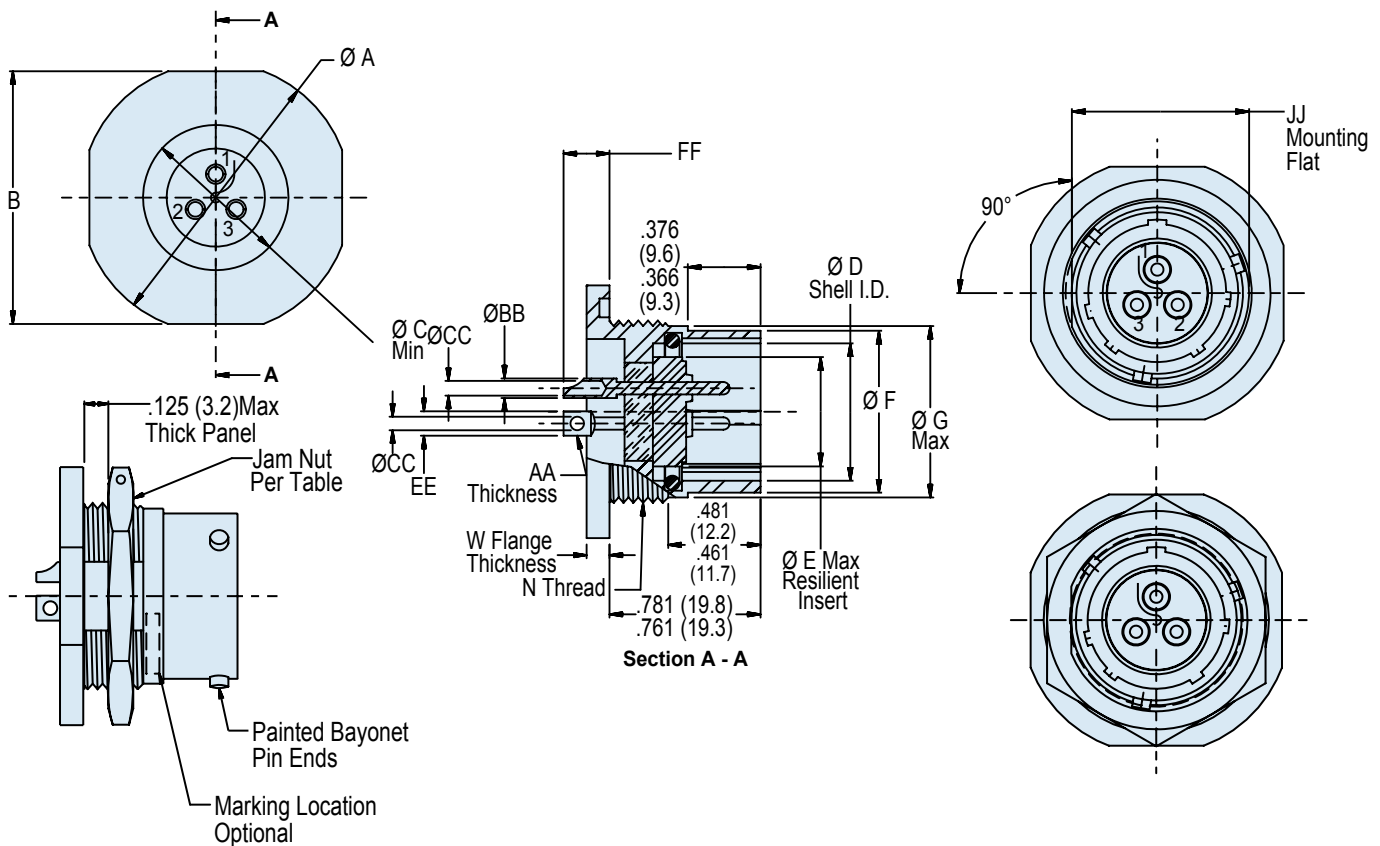

Dimensions in Inches (millimeters) are subject to change without notice.

230-039

# MIL-DTL-26500 Type Hermetic Class Receptacle

## Single Hole Mount, Bayonet Coupling, MS24265H\*B\* Type

MIL-DTL-26500  
Type

TABLE I: Shell Size, Connector Dimensions and Panel Cut-Out

Shell Size	Ø A Max	B	Ø C Min	Ø D Shell I.D.	Ø E Resilient Insert	Ø F	Ø G Max	N Thread	JJ Mounting Flat	Flange Thickness W ± .020 (0.5)	Panel Cut-Out EE	Panel Cut-Out FF	Jam Nut MS3186
8	1.068 (27.1)	.979 (24.9)	.493 (12.5)	.433/.428 (11.0/10.9)	.312 (7.9)	.536/.531 (13.6/13.5)	.561 (14.2)	.625-20 UN-2A	.596/.590 (15.1/15.0)	.117 (3.0)	.605 (15.4)	.635 (16.1)	-105
10	1.192 (30.3)	1.104 (28.0)	.555 (14.1)	.535/.530 (13.6/13.5)	.388 (9.9)	.659/.654 (16.7/16.6)	.696 (17.7)	.750-20 UNEF 2A	.721/.715 (18.3/18.2)	.117 (3.0)	.730 (18.5)	.760 (19.3)	-107
12	1.380 (35.1)	1.291 (32.8)	.743 (18.9)	.705/.700 (17.9/17.8)	.558 (14.2)	.829/.824 (21.1/20.9)	.875 (22.2)	.937-20 UNEF-2A	.908/.902 (23.1/22.9)	.117 (3.0)	.917 (23.3)	.947 (24.1)	-110
14	1.505 (28.2)	1.391 (35.3)	.805 (20.4)	.774/.769 (19.7/19.5)	.627 (15.9)	.898/.893 (22.8/22.7)	.935 (23.7)	1.000-20 UNEF-2A	.971/.965 (24.7/24.5)	.117 (3.0)	.980 (24.9)	1.010 (25.7)	-111
16	1.630 (41.4)	1.516 (38.5)	.931 (23.6)	.901/.896 (22.9/22.8)	.772 (19.6)	1.025/1.020 (26.0/25.9)	1.062 (27.0)	1.125-20 UNEF-2A	1.096/1.090 (27.8/27.7)	.117 (3.0)	1.105 (28.1)	1.135 (28.8)	-112
18	1.765 (44.8)	1.641 (41.7)	1.055 (26.8)	1.007/1.002 (25.6/25.5)	.860 (21.8)	1.131/1.126 (28.7/28.6)	1.187 (30.1)	1.250-18 UNEF-2A	1.220/1.214 (31.0/30.8)	.117 (3.0)	1.229 (31.2)	1.260 (32.0)	-116
20	1.860 (47.2)	1.766 (44.9)	1.243 (31.6)	1.132/1.125 (28.8/28.6)	.985 (25.0)	1.256/1.251 (31.9/31.8)	1.312 (33.3)	1.375-18 UNEF-2A	1.345/1.339 (34.2/34.0)	.117 (3.0)	1.354 (34.4)	1.385 (35.2)	-117
22	2.068 (52.5)	1.954 (49.6)	1.305 (33.1)	1.257/1.252 (31.9/31.8)	1.110 (28.2)	1.381/1.376 (35.1/35.0)	1.437 (36.5)	1.500-18 UNEF-2A	1.470/1.464 (37.3/37.2)	.148 (3.8)	1.497 (38.0)	1.510 (38.4)	-120
24	2.160 (54.9)	2.079 (52.8)	1.493 (37.9)	1.382/1.377 (35.1/35.0)	1.235 (31.4)	1.506/1.501 (38.3/38.1)	1.562 (39.7)	1.625-18 UNEF-2A	1.595/1.589 (40.5/40.4)	.148 (3.8)	1.604 (40.7)	1.635 (41.5)	-121

TABLE II: Contacts

Contact Size	Contact Type	AA	ØØ BB	ØØ CC Min	DD	FF Max
12	Cup	--	.150 (3.8)	.112 (2.8)	--	.235 (6.0)
12	Eyelet	.035 (0.9)	--	--	.200 (5.1)	.235 (6.0)
16	Cup	--	.103 (2.6)	.069 (1.8)	--	.235 (6.0)
16	Eyelet	.025 (0.6)	--	--	.125 (3.2)	.235 (6.0)
20	Cup	--	.077 (2.0)	.042 (1.1)	--	.165 (4.2)
20	Eyelet	.015 (0.4)	--	--	.080 (2.0)	.165 (4.2)

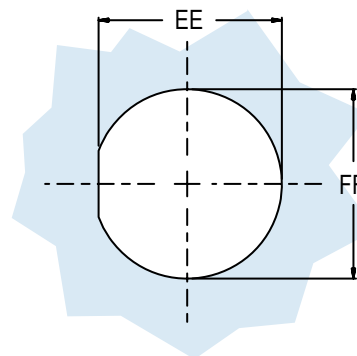

## APPLICATION NOTES

- Assembly identified with manufacturer's name and part number, space permitting.
- Glenair 230-039 will mate with any QPL MIL-DTL-MS24266 type bayonet coupling plug of same size, keyway and insert polarization.
- Performance:
  - Hermeticity -  $< \times 10^{-7}$  ccHe/sec @ 1 atmosphere differential
  - Dielectric withstanding voltage - consult factory or MIL-STD-1554
  - Insulation resistance - 5000 megohms min @ 500VDC
- Material/ Finish:
  - Shell and Jam Nut—specified by class
  - Pin contacts—nickel-iron alloy 52/gold
  - Bayonets—Cres/Passivated
  - Contacts—52 Nickel alloy/Gold plated
  - Insulators—Glass/NA
  - Seals—fluorosilicone elastomer N.A.
- Metric Dimensions (mm) are indicated in parentheses.

Dimensions in Inches (millimeters) are subject to change without notice.

© 2013 Glenair, Inc.

U.S. CAGE Code 06324

Printed in U.S.A.

GLENAIR, INC. • 1211 AIR WAY • GLENDALE, CA 91201-2497 • 818-247-6000 • FAX 818-500-9912  
 www.glenair.com F-13 E-Mail: sales@glenair.com



**How To Order: Commercial**

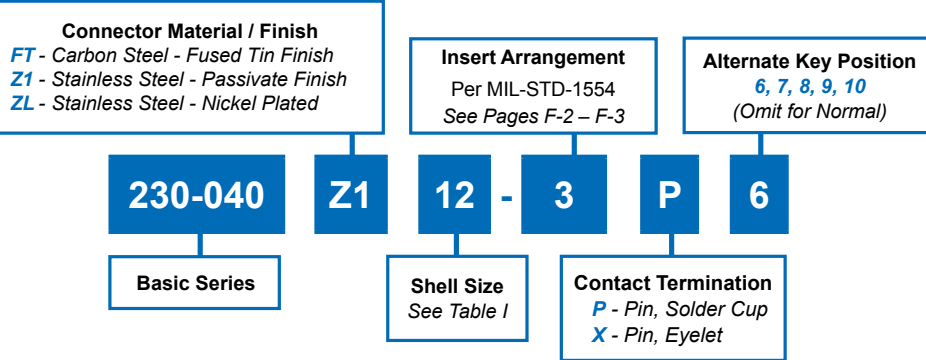

F

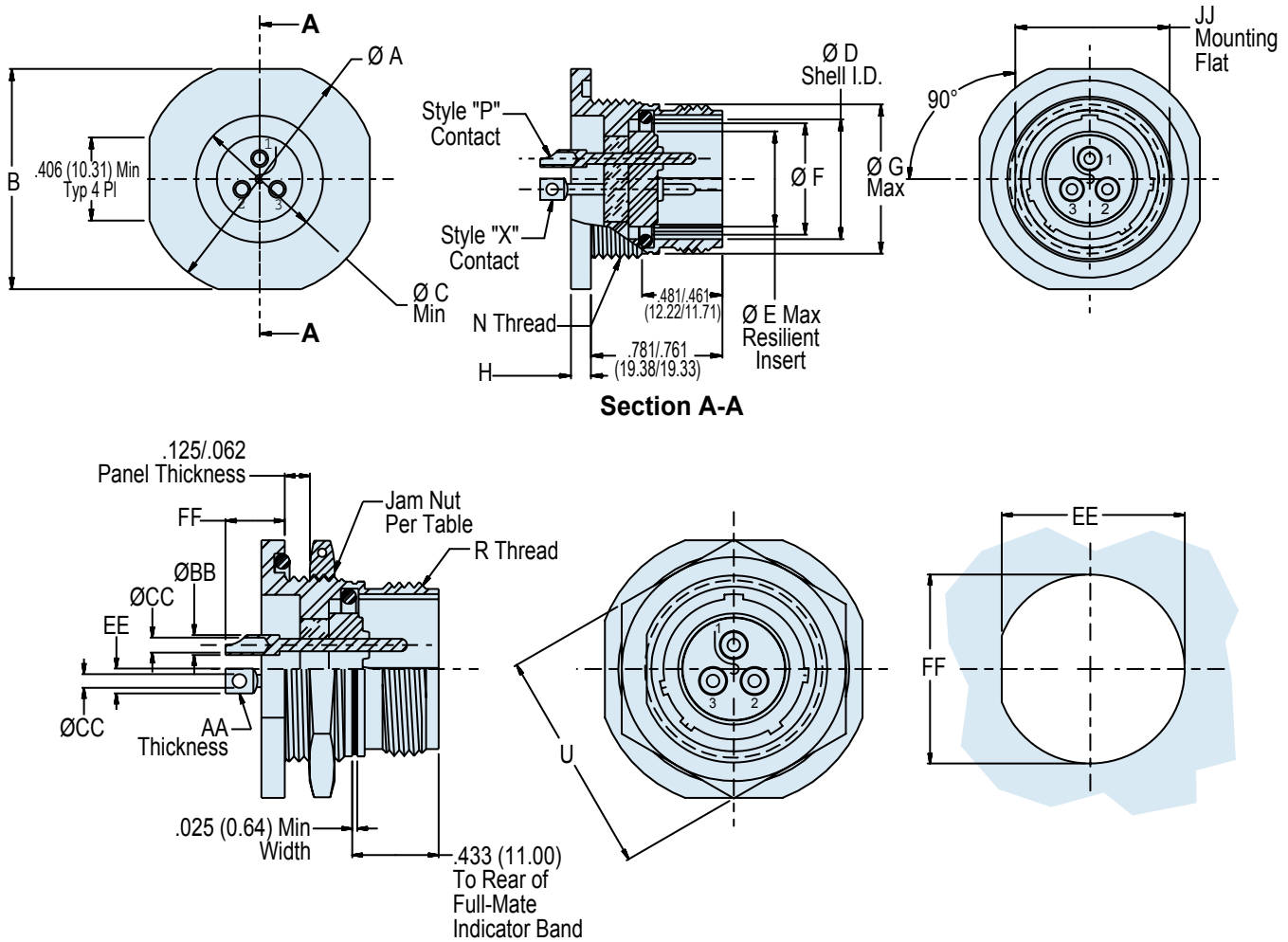

Dimensions in Inches (millimeters) are subject to change without notice.

230-040

# MIL-DTL-26500 Type Hermetic Class Receptacle Single Hole Mount, Threaded Coupling, MS24265 Type

MIL-DTL-26500  
Type
**TABLE I: Shell Size, Connector Dimensions and Panel Cut-Out**

Shell Size	Ø A Max	B	Ø D Shell I.D.	Ø E Resilient Insert	Ø G Max	H Flange Thickness	N Thread	R Thread	JJ Mounting Flat	Panel Cut-Out EE	Panel Cut-Out FF	U Hex Max
8	1.068 (27.1)	.984/.974 (24.99/24.74)	.433/.428 (11.0/10.9)	.318 (8.08)	.561 (14.2)	.137/.097 (3.48/2.46)	.625-20 UN-2A	.562-24 UNEF-2A	.596/.590 (15.1/15.0)	.605 (15.37)	.635 (16.1)	.828 (21.03)
10	1.192 (30.3)	1.109/1.099 (28.17/27.91)	.535/.530 (13.6/13.5)	.394 (10.01)	.696 (17.7)	.137/.097 (3.48/2.46)	.750-20 UNEF 2A	.687-24 UNEF 2A	.721/.715 (18.3/18.2)	.730 (18.54)	.760 (19.3)	.953 (24.21)
12	1.380 (35.1)	1.296/1.286 (32.92/32.66)	.705/.700 (17.9/17.8)	.564 (14.33)	.875 (22.2)	.137/.097 (3.48/2.46)	.937-20 UNEF-2A	.875-20 UNEF-2A	.908/.902 (23.1/22.9)	.917 (23.29)	.947 (24.1)	1.140 (28.96)
14	1.505 (38.2)	1.399/1.386 (35.53/35.20)	.774/.769 (19.7/19.5)	.633 (16.08)	.935 (23.7)	.137/.097 (3.48/2.46)	1.000-20 UNEF-2A	.937-20 UNEF-2A	.971/.965 (24.7/24.5)	.980 (24.89)	1.010 (25.7)	1.250 (31.75)
16	1.630 (41.4)	1.521/1.511 (38.63/38.38)	.901/.896 (22.9/22.8)	.780 (19.81)	1.062 (27.0)	.137/.097 (3.48/2.46)	1.125-20 UNEF-2A	1.062-18 UNEF-2A	1.096/1.090 (27.8/27.7)	1.105 (28.07)	1.135 (28.8)	1.329 (33.76)
18	1.740 (44.2)	1.646/1.636 (41.81/41.55)	1.007/1.002 (25.6/25.5)	.866 (22.00)	1.187 (30.1)	.137/.097 (3.48/2.46)	1.250-20 UNEF-2A	1.187-18 UNEF-2A	1.220/1.214 (31.0/30.8)	1.225 (31.12)	1.260 (32.0)	1.455 (36.96)
20	1.860 (47.2)	1.771/1.761 (44.98/44.73)	1.132/1.127 (28.8/28.6)	.991 (25.17)	1.312 (33.3)	.137/.097 (3.48/2.46)	1.375-18 UNEF-2A	1.312-18 UNEF-2A	1.345/1.339 (34.2/34.0)	1.350 (34.29)	1.385 (35.2)	1.642 (41.71)
22	2.040 (51.8)	1.959/1.949 (49.76/49.50)	1.257/1.252 (31.9/31.8)	1.116 (28.35)	1.437 (36.5)	.168/.128 (4.27/3.25)	1.500-18 UNEF-2A	1.437-18 UNEF-2A	1.470/1.464 (37.3/37.2)	1.475 (37.47)	1.510 (38.4)	1.705 (43.31)
24	2.160 (54.9)	2.084/2.074 (52.93/52.68)	1.382/1.377 (35.1/35.0)	1.241 (31.52)	1.562 (39.7)	.168/.128 (4.27/3.25)	1.625-18 UNEF-2A	1.562-18 UNEF-2A	1.595/1.589 (40.5/40.4)	1.600 (40.64)	1.635 (41.5)	1.892 (48.06)

**TABLE II: Contacts**

Contact Size	Contact Type	AA	ØØ BB	ØØ CC Min	DD	FF Max
12	Cup	--	.150 (3.8)	.112 (2.8)	--	.235 (6.0)
12	Eyelet	.035 (0.9)	--	--	.200 (5.1)	.235 (6.0)
16	Cup	--	.103 (2.6)	.069 (1.8)	--	.235 (6.0)
16	Eyelet	.025 (0.6)	--	--	.125 (3.2)	.235 (6.0)
20	Cup	--	.077 (2.0)	.042 (1.1)	--	.165 (4.2)
20	Eyelet	.015 (0.4)	--	--	.080 (2.0)	.165 (4.2)

**APPLICATION NOTES**

- Assembly identified with manufacturer's name and part number, space permitting.
- Glenair 230-040 will mate with any QPL MIL-DTL-MS26500/MS24266 type threaded coupling plug of same size, keyway and insert polarization.
- Performance:  
Hermeticity -  $< \times 10^{-7}$  ccHe/sec @ 1 atmosphere differential  
Dielectric withstanding voltage - consult factory or MIL-STD-1554  
Insulation resistance - 5000 megohms min @ 500VDC
- Material/ Finish:  
Shell and Jam Nut—specified by class  
Contacts—52 Nickel alloy/Gold plated  
Insulators—Glass/N.A.  
Seals—fluorosilicone elastomer/N.A.
- Metric Dimensions (mm) are indicated in parentheses.

Dimensions in Inches (millimeters) are subject to change without notice.

© 2013 Glenair, Inc.

U.S. CAGE Code 06324

Printed in U.S.A.

**GLENAIR, INC. • 1211 AIR WAY • GLENDALE, CA 91201-2497 • 818-247-6000 • FAX 818-500-9912**  
**www.glenair.com F-15 E-Mail: sales@glenair.com**

F

**How To Order: Commercial**

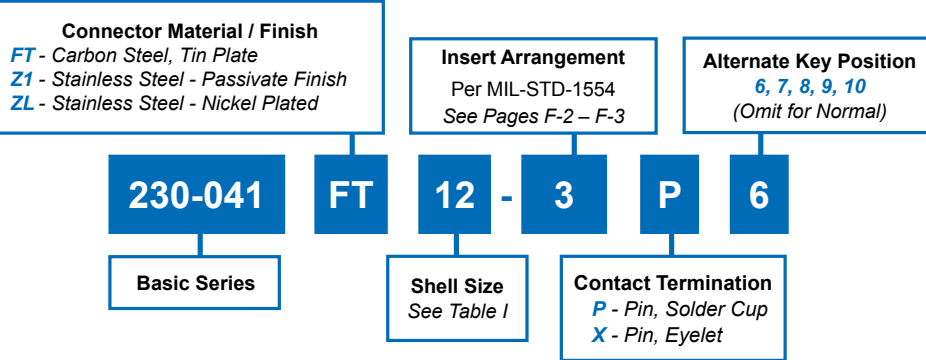

**F**

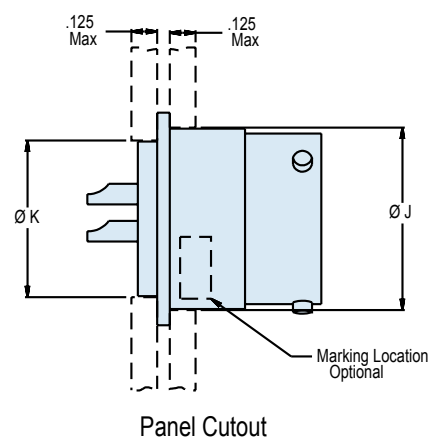
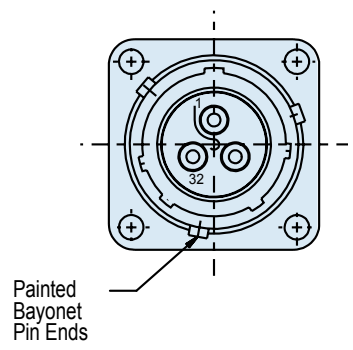
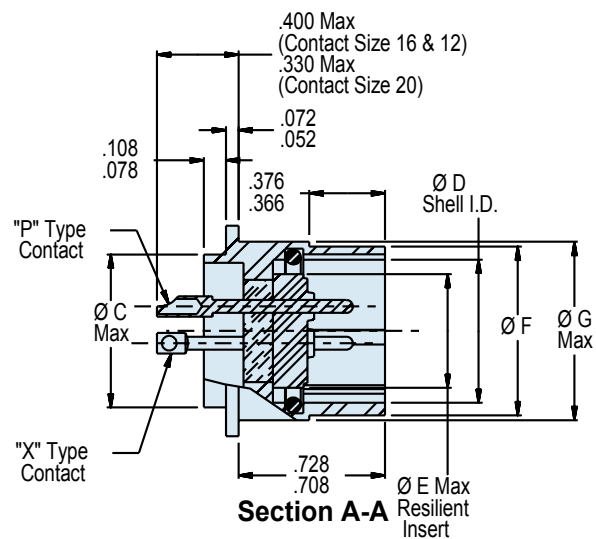
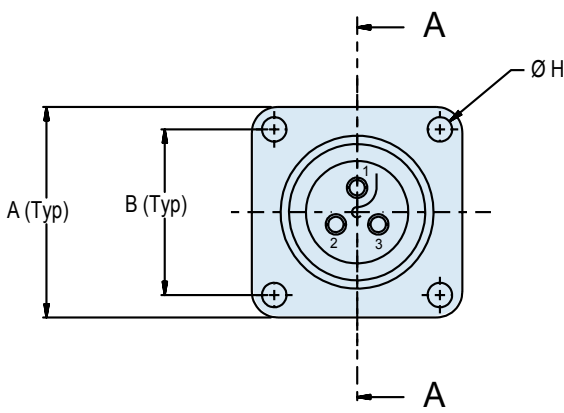

Dimensions in Inches (millimeters) are subject to change without notice.

**230-041**  
**MIL-DTL-26500 Type Hermetic Class Receptacle**  
**Square Flange Mount, Bayonet Coupling**



MIL-DTL-26500  
Type

**TABLE I: Shell Size, Connector Dimensions and Panel Cut-Out**

Shell Size	A	B	CØ Max	DØ Shell I.D.	EØ Resilient Insert	FØ	GØ Max	HØ Thru 4 Pl.	Panel Cutout Rear Mount JØ	Panel Cutout Front Mount K Ø
8	0.812 (20.6)	0.594 (15.1)	0.437 (11.1)	.433/.428 (11.0/10.9)	0.312 (7.9)	.536/.531 (13.6/13.5)	0.561 (14.2)	0.120 (3.0)	.630/.620 (16.0/15.7)	.457/.447 (11.6/11.4)
10	0.937 (23.8)	0.719 (18.3)	0.562 (14.3)	.535/.530 (13.6/13.5)	0.388 (9.9)	.659/.654 (16.7/16.6)	0.696 (17.7)	0.120 (3.0)	.758/.748 (19.3/19.0)	.582/.572 (14.8/14.5)
12	1.031 (26.2)	0.812 (20.6)	0.750 (19.1)	.705/.700 (17.9/17.8)	0.558 (14.2)	.829/.824 (21.1/20.9)	0.875 (22.2)	0.120 (3.0)	.923/.913 (23.4/23.2)	.770/.760 (19.6/19.3)
14	1.125 (28.6)	0.906 (23.0)	0.812 (20.6)	.774/.769 (19.7/19.5)	0.627 (15.9)	.898/.893 (22.8/22.7)	0.935 (23.7)	0.120 (3.0)	.990/.980 (25.1/24.9)	.832/.822 (21.1/20.9)
16	1.250 (31.8)	0.969 (24.6)	0.937 (23.8)	.901/.896 (22.9/22.8)	0.772 (19.6)	1.025/1.020 (26.0/25.9)	1.062 (27.0)	0.120 (3.0)	1.117/1.107 (28.4/28.1)	.958/.948 (24.3/24.1)
18	1.343 (34.1)	1.062 (27.0)	1.062 (27.0)	1.007/1.002 (25.6/25.5)	0.860 (21.8)	1.131/1.126 (28.7/28.6)	1.187 (30.1)	0.120 (3.0)	1.219/1.209 (31.0/30.7)	1.082/1.072 (27.5/27.2)
20	1.437 (36.5)	1.156 (29.4)	1.187 (30.1)	1.132/1.125 (28.8/28.6)	0.985 (25.0)	1.256/1.251 (31.9/31.8)	1.312 (33.3)	0.120 (3.0)	1.347/1.337 (34.2/34.0)	1.202/1.192 (30.5/30.3)
22	1.562 (39.7)	1.250 (31.8)	1.312 (33.3)	1.257/1.252 (31.9/31.8)	1.110 (28.2)	1.381/1.376 (35.1/35.0)	1.437 (36.5)	0.120 (3.0)	1.462/1.452 (37.1/36.9)	1.332/1.322 (33.8/33.6)
24	1.703 (43.3)	1.375 (34.9)	1.437 (36.5)	1.382/1.377 (35.1/35.0)	1.235 (31.4)	1.506/1.501 (38.3/38.1)	1.562 (39.7)	0.149 (3.8)	1.587/1.577 (40.3/40.1)	1.452/1.442 (36.9/36.6)

F

**APPLICATION NOTES**

- Assembly identified with manufacturer's name and part number, space permitting.
- Glenair 230-041 will mate with any QPL MIL-DTL-MS24266 type bayonet coupling plug of same size, keyway and insert polarization.
- Performance:  
 Hermeticity -  $<10^{-7}$  ccHe/sec @ 1 atmosphere differential  
 Dielectric withstanding voltage - consult factory or MIL-STD-1554  
 Insulation resistance - 5000 megohms min @ 500VDC
- Material/ Finish:  
 Shell—specified by class  
 Bayonets—Stainless Steel/Passivated  
 Contacts—52 Nickel alloy/Gold plated  
 Insulators—Glass/NA  
 Seals—fluorosilicone elastomer N.A.
- Metric Dimensions (mm) are indicated in parentheses.

Dimensions in Inches (millimeters) are subject to change without notice.

**How To Order: Commercial**

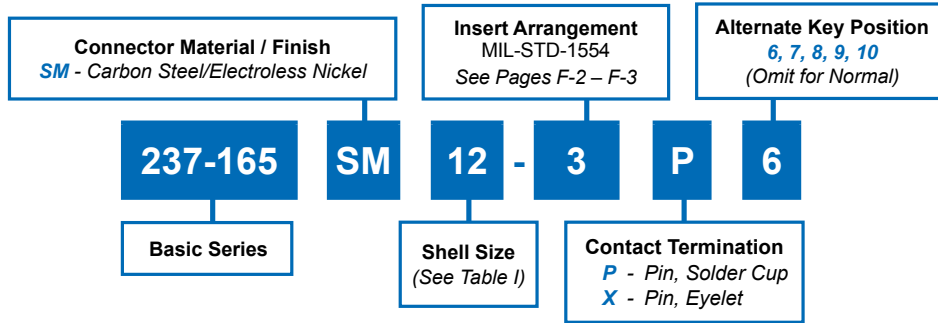

**F**

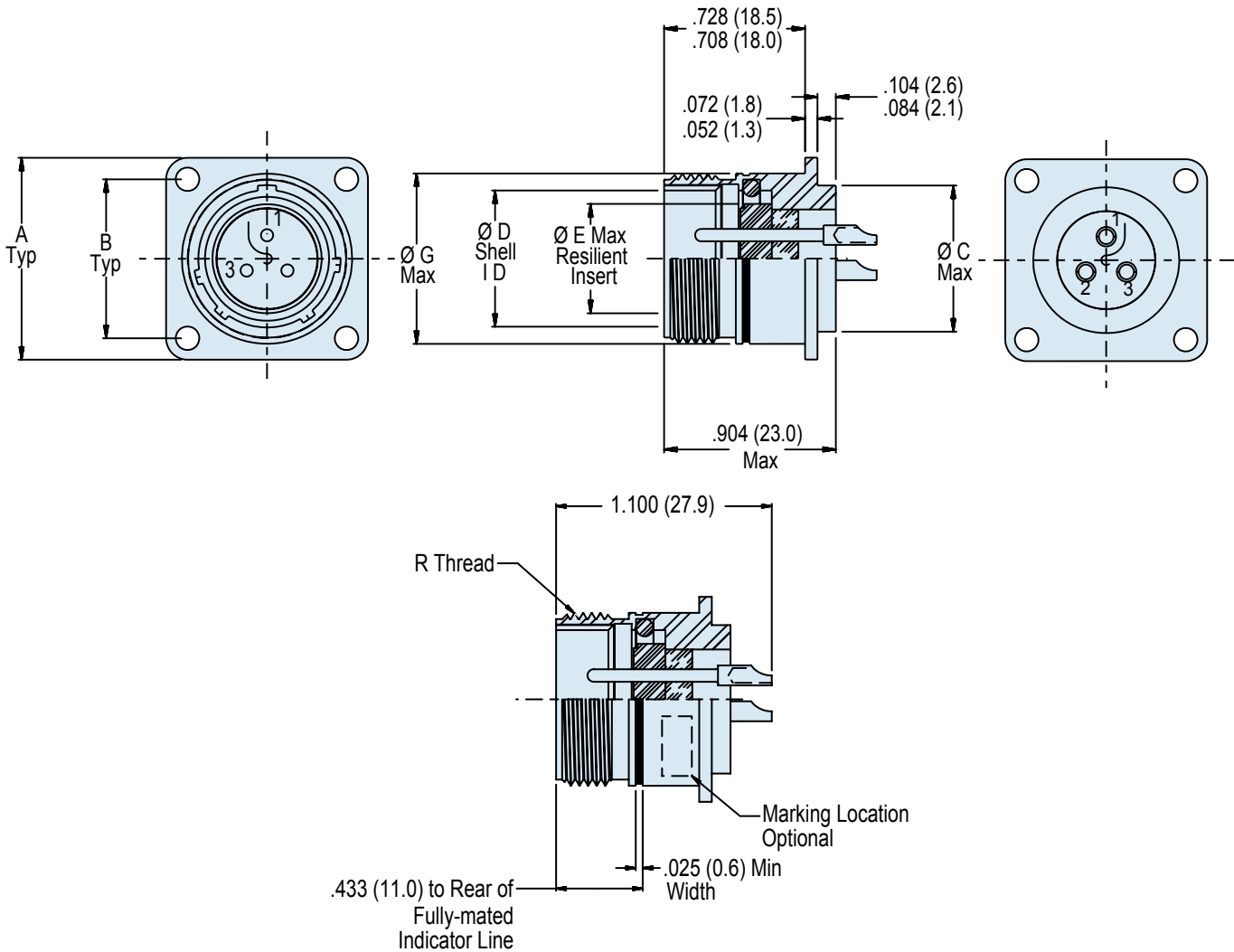

Dimensions in Inches (millimeters) are subject to change without notice.

**237-165**  
**MIL-DTL-26500 Type Hermetic Class Receptacle**  
**MS26424H\*T\*\* Type Square Flange Mount, Threaded Coupling**



MIL-DTL-26500  
Type

**F**

**TABLE I: Shell Size, Connector Dimensions and Panel Cut-Out**

Shell Size	A	B	Ø C	Ø D Shell I.D.	Ø E Max Resilient Insert	Ø G Max	Ø H Through 4 Places	R Coupling Thread UNEF-2A	Panel Cut-Out Min Ø
8	.812 (20.6)	.594 (15.1)	.500/.494 (12.7/12.5)	.433/.428 (11.0/10.9)	.318 (8.1)	.561 (14.2)	.125/.116 (3.2/2.9)	.562-24	.572 (14.5)
10	.937 (23.8)	.719 (18.3)	.562/.556 (14.3/14.1)	.535/.530 (13.6/13.5)	.394 (10.0)	.696 (17.7)	.125/.116 (3.2/2.9)	.688-24	.706 (17.9)
12	1.031 (26.2)	.812 (20.6)	.750/.744 (19.1/18.9)	.705/.700 (17.9/17.8)	.564 (14.3)	.875 (22.2)	.125/.116 (3.2/2.9)	.875-20	.885 (22.5)
14	1.125 (28.6)	.906 (23.0)	.812/.806 (20.6/20.5)	.774/.769 (19.7/19.5)	.633 (16.1)	.935 (23.7)	.125/.116 (3.2/2.9)	.938-20	.946 (24.0)
16	1.250 (31.8)	.969 (24.6)	.937/.931 (23.8/23.6)	.901/.896 (22.9/22.8)	.760 (19.3)	1.062 (27.0)	.125/.116 (3.2/2.9)	1.062-18	1.072 (27.2)
18	1.343 (34.1)	1.062 (27.0)	1.062/1.056 (27.0/26.8)	1.007/1.002 (25.6/25.5)	.866 (22.0)	1.187 (30.1)	.125/.116 (3.2/2.9)	1.188-18	1.197 (30.4)
20	1.437 (36.5)	1.156 (29.4)	1.187/1.181 (30.1/30.0)	1.132/1.125 (28.8/28.6)	.991 (25.2)	1.312 (33.3)	.125/.116 (3.2/2.9)	1.312-18	1.322 (33.6)
22	1.562 (39.7)	1.250 (31.8)	1.312/1.306 (33.3/33.2)	1.257/1.252 (31.9/31.8)	1.116 (28.3)	1.437 (36.5)	.125/.116 (3.2/2.9)	1.438-18	1.447 (36.8)
24	1.703 (43.3)	1.375 (34.9)	1.437/1.431 (36.5/36.3)	1.382/1.377 (35.1/35.0)	1.241 (31.5)	1.562 (39.7)	.154/.145 (3.9/3.7)	1.562-18	1.572 (39.9)

**APPLICATION NOTES**

- Assembly identified with manufacturer's name and part number, space permitting.
- Glenair 237-165 will mate with any QPL MIL-DTL-26500 type threaded coupling plug of same size, keyway and insert polarization.
- Performance:  
 Hermeticity -  $<10^{-7}$  ccHe/sec @ 1 atmosphere differential  
 Dielectric withstanding voltage - consult factory or MIL-STD-1554  
 Insulation resistance - 5000 megohms min @ 500VDC
- Material/ Finish:  
 Shell—C1215 Steel/Electroless nickel  
 Contacts—52 Nickel alloy/Gold plated  
 Insulators—Glass/NA  
 Seals—fluorosilicone elastomer N.A.
- Metric Dimensions (mm) are indicated in parentheses.

Dimensions in Inches (millimeters) are subject to change without notice.



POWER AND  
SIGNAL

# MIL-DTL-5015

*Type Glass Seal Hermetic Connectors*



Glenair MIL-DTL-5015 type commercial hermetic connectors are general purpose, low-density circular connectors ideally suited for applications that require power and signal contacts in a glass sealed hermetic package. This series is available in a wide range of shell sizes and contact layouts that are compatible with all standard environmental MIL-DTL-5015 plug connectors. Because Glenair makes all its hermetic connectors in-house, including the machining of shells, molding of interfacial seals and firing of hermetic components, we can offer you outstanding availability on stock products and fast turnaround on special orders. Glenair also makes and stocks all the standard connector accessory backshells typically specified with 5015 type connectors.

GLASS-SEALED  
**Hermetic**  
CONNECTORS

**G**lenair®

Glenair, Inc.  
1211 Air Way  
Glendale, CA  
91201-2497  
818-247-6000  
sales@glenair.com  
www.glenair.com





**Corrosion Resistant Stainless Steel Harsh Environment Glass Seal Hermetic Connectors for Power and Signal Applications**

Glenair MIL-DTL-5015 type hermetic connectors are made from passivated stainless steel or ferrous steel shells, with glass insulators fused to the connector shell, and contacts meeting a leak rate of 1 X 10<sup>-7</sup> cc/helium per second. The Glenair MIL-DTL-5015 type hermetic connector is equipped with fluorosilicone elastomer

interfacial and peripheral seals which provide positive sealing with plug connectors. Gold plated nickel-iron alloy 52 contacts are available in sizes 0, 4, 8, 10, 12 and 16, depending on the layout chosen. Solder cup and eyelet contact styles are standard.

Quick Selection Guide		
Part Number	Description	Page
	MIL-DTL-5015 Type Insert Arrangements	G-2
	MIL-DTL-5015 Type Alternate Key Positions	G-5
<b>250-013</b>	Threaded Coupling Square Flange Receptacle MS3142 Type	G-6
<b>250-014</b>	Threaded Coupling Solder Mount Receptacle MS3143 Type	G-8
<b>250-015</b>	Threaded Coupling Box Mount Receptacle Connector MS3142 Type	G-10
<b>250-016</b>	Threaded Coupling Solder Mount Receptacle Connector MS3143 Type Sockets	G-12
<b>250-025</b>	Threaded Coupling Flangeless Mount Receptacle Connector MS3143 Type	G-14
<b>257-384</b>	Jam Nut Mount Receptacle Connector MS3404 Type	G-16
<b>947-042</b>	Jam Nut Mount Bulkhead Feed-Thru Connector with Pin/Socket Contacts	G-18
<b>947-056</b>	Jam Nut Mount Bulkhead Feed-Thru Connector with Pin/Pin Contacts	G-20
<b>947-259</b>	Panel Mount Bulkhead Feed-Thru Receptacle	G-22
<b>947-371</b>	Jam Nut Mount Bulkhead Feed-Thru Receptacle	G-24



## MIL-DTL-5015 Type Hermetic Power and Signal Connectors Insert Arrangements per MIL-STD-1651

G

Insert Arrangements						
Pattern Number	Contact Size and Quantity					Service Rating
	16	12	8	4	0	
8S-1	1					A
10S-2	1					A
10SL-3	3					INST
10SL-4	2					A
12S-3	2					A
12S-4	1					D
12-5		1				D
14S-1	3					A
14S-2	4					INST
14-3			1			A
14S-4	1					D
14S-5	5					INST
14S-6	6					INST
14S-7	3					A
14S-9	2					A
16S-1	7					A
16-2		1				E
16S-3	1					B
16S-4	2					D
16S-5	3					A
16S-6	3					A
16-7	2		1			A
16S-8	5					A
16-9	2	2				A
16-10		3				A
16-11		2				A
16-12				1		A
16-13		2				A
18-1	10					A/INST
18-3		2				D
18-4	4					D
18-5	1	2				D
18-6				1		D
18-7			1			B
18-8	7	1				A
18-9	5	2				INST
18-10		4				A
18-11		5				A
18-12	6					A
18-13		3	1			A
18-14	1			1		A
18-15		4				A

Insert Arrangements						
Pattern Number	Contact Size and Quantity					Service Rating
	16	12	8	4	0	
18-16		1				C
18-20	5					A
18-22	3					D
18-29	5					A
20-2					1	D
20-3		3				D
20-4		4				D
20-5	2					E
20-6	3					D
20-7	8					D/A
20-8	4		2			INST
20-9	7	1				D/A
20-11	13					INST
20-12	1			1		A
20-13	4					A
20-14		3	2			A
20-15		7				A
20-16	7	2				A
20-17	1	5				A
20-18	6	3				A
20-19			3			A
20-20		3		1		A
20-21	8	1				
20-22	3		3			A
20-23			2			A
20-24	2		2			A
20-27	14					A
20-29	17					A
20-31	11					A
20-33	11					A
22-1			2			D
22-2			3			D
22-3	1			1		D
22-4		2	2			A
22-5	4	2				D
22-6	1		2			D
22-7					1	E
22-8		2				E
22-9		3				E
22-10	4					E
22-11	2					B
22-12	3		2			D

Dimensions in Inches (millimeters) are subject to change without notice.

**MIL-DTL-5015 Type Hermetic  
Power and Signal Connectors  
Insert Arrangements per MIL-STD-1651**



MIL-DTL-5015  
Type

Insert Arrangements						
Pattern Number	Contact Size and Quantity					Service Rating
	16	12	8	4	0	
22-13	1	4				D
22-14	19					A
22-15	1	5				E/A
22-17	8	1				D/A
22-18	8					A/D
22-19	14					A
22-20	9					A
22-21	2				1	A
22-22			4			A
22-23		8				D/A
22-24	4	2				D/A
22-25	2				1	A
24-1		1			1	D
24-2		7				D
24-3	5	2				D
24-4	3				1	D
24-5	16					A
24-6		8				D/A
24-7	14	2				A
24-9				2		A
24-10			7			A
24-11		6	3			A
24-12		3		2		A
24-14		2			1	A
24-16	3	3	1			D/A
24-17	3	2				D
24-20	9	2				D
24-21	9		1			D
24-22			4			D
24-23	2		3			D
24-27	7					E
24-28	24					INST
24-80	23					INST
28-1		6	3			D/A
28-2	12	2				D
28-3			3			E
28-4	7	2				E/D
28-5	2	1		2		D
28-6				3		D
28-8	10	2				E/D/A
28-9	6	6				D
28-10		3	2	2		D/A

Insert Arrangements						
Pattern Number	Contact Size and Quantity					Service Rating
	16	12	8	4	0	
28-11	18	4				A
28-12	26					A
28-14	11					D
28-15	35					A
28-16	20					A
28-17	15					B/D/A
28-18	12					D/C/A/N
28-19	6	4				D/B/A/INST
28-20	4	10				A
28-21	37					A
28-22	3			3		D
32-1		3			2	E/D
32-2	2			3		E
32-3	4	2		2	1	D
32-4	12	2				D/A
32-5					2	D
32-6	16	2	3	2		A
32-7	28	7				INST/A
32-8	24	6				A
32-9	12			2		D
32-10	3		2	2		E/D/B/A
32-12	10	5				D/A
32-13	18	5				D
32-14		5		2		D
32-15		6			2	D
32-17				4		D
32-22	54					A
32-63				5		D
32-73	46					A
36-1	18	4				D
36-3		3			3	D
36-4					3	D/A
36-5					4	A
36-6				4	2	A
36-7	40	7				A
36-8	46	1				A
36-9	14	14	2	1		A
36-10	48					A
36-13	15	2				E/A
36-14	6	5	5			D
36-15	35					D/A
36-19	10	5		1	1	D

Dimensions in Inches (millimeters) are subject to change without notice.





## MIL-DTL-5015 Type Hermetic Power and Signal Connectors Insert Arrangements per MIL-STD-1651

Insert Arrangements						
Pattern Number	Contact Size and Quantity					Service Rating
	16	12	8	4	0	
36-52	52					A
36-66	52	4				A
40-1	24	6				D
40-2	23					D/B
40-3	18	4		1		D
40-4	16	2	3	2		D
40-5		6	4	2	3	A
40-6	24	1			1	D
40-7	18	2			2	D/A
40-9	24	22	1			A
40-10	16		9	4		A
40-11	18	4	1	1	1	D
40-56	85					A
40-62	60					A
44-1	36	6				D
44-2	14	14	2	1		D
44-3	24	3	2	2		D
44-4	31	8			2	D
44-52	104					A
48-1		6	4	2	3	E/D
48-2	46	1				E/D
48-3	18	1	3		3	D
48-4	47	16	3		2	D/A
48-62	85					D

Dimensions in Inches (millimeters) are subject to change without notice.

# MIL-DTL-5015 Type Hermetic Power and Signal Connectors Alternate Key Positions



MIL-DTL-5015  
Type



Alternate Key Positions				
Dash Number	W°	X°	Y°	Z°
8S-1	-	-	-	-
10S-2	-	-	-	-
10SL-3	-	-	-	-
10SL-4	-	-	-	-
12S-3	70	145	215	290
12S-4	-	-	-	-
14S-1	-	-	-	-
14S-2	-	120	240	-
14S-4	-	-	-	-
14S-5	-	110	-	-
14S-6	-	-	-	-
14S-7	90	180	270	-
14S-9	70	145	215	290
16S-1	80	-	-	280
16S-3	-	-	-	-
16S-4	35	110	250	325
16S-5	70	145	215	290
16S-6	90	180	270	-
16S-8	-	170	265	-
16-9	35	110	250	325
16-10	90	180	270	-
16-11	35	110	250	325
18-1	70	145	215	290
18-4	35	110	250	325
18-8	70	-	-	290
18-9	80	110	250	280
18-10	-	120	240	-
18-11	-	170	265	-
18-12	80	-	-	280
20-4	45	110	250	-
20-7	80	110	250	280
20-8	80	110	250	280
20-14	80	110	250	280
20-15	80	-	-	280
20-16	80	110	250	280
20-17	90	180	270	-
20-18	35	110	250	325
20-19	90	180	270	-

Alternate Key Positions				
Dash Number	W°	X°	Y°	Z°
20-22	80	110	250	280
20-24	35	110	250	325
20-27	35	110	250	325
20-29	80	-	-	280
20-33	-	-	-	-
22-2	70	145	215	290
22-5	35	110	250	325
22-9	70	145	215	290
22-14	80	-	-	280
22-18	80	110	250	280
22-19	80	110	250	280
22-20	35	110	250	325
22-22	-	110	250	-
22-23	35	-	250	-
24-2	80	-	-	280
24-4	80	110	250	280
24-7	80	110	250	280
24-10	80	-	-	280
24-11	35	110	250	325
24-19	-	-	-	-
24-20	80	110	250	280
24-27	80	-	-	280
24-28	80	110	250	280
28-9	80	110	250	280
28-11	80	110	250	280
28-12	90	180	280	-
28-15	80	110	250	280
28-17	80	110	250	280
28-20	80	110	250	280
28-21	80	110	250	280
32-6	80	110	250	280
32-7	80	125	235	280
32-8	80	125	235	280
32-15	35	110	250	280
32-17	45	110	250	-
36-5	-	120	240	-
36-7	80	110	250	280
36-9	80	125	235	280
36-10	80	125	235	280

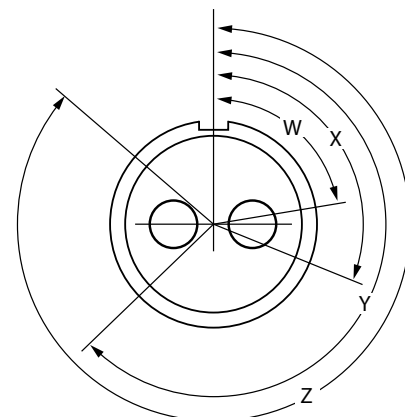

Pin Insert Face View  
Normal Insert  
Keying Shown

Dimensions in Inches (millimeters) are subject to change without notice.

© 2013 Glenair, Inc.

U.S. CAGE Code 06324

Printed in U.S.A.

# 250-013 MIL-DTL-5015 Type Hermetic Threaded Coupling Box Mount Receptacle Connector MS3142 Type

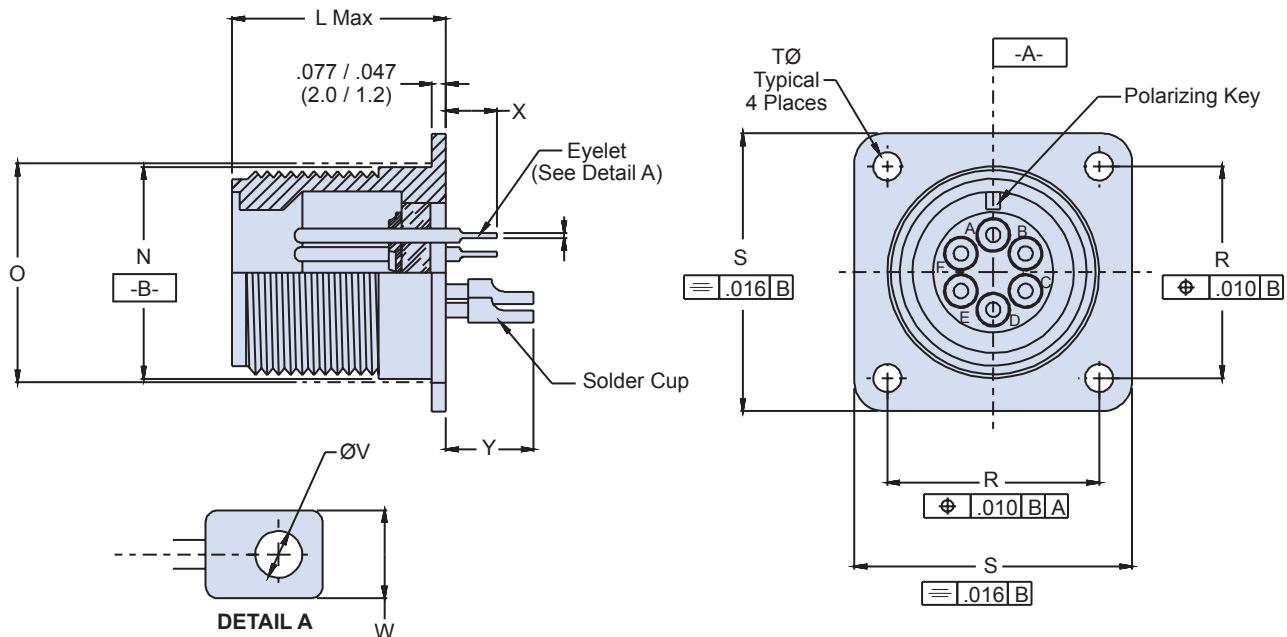
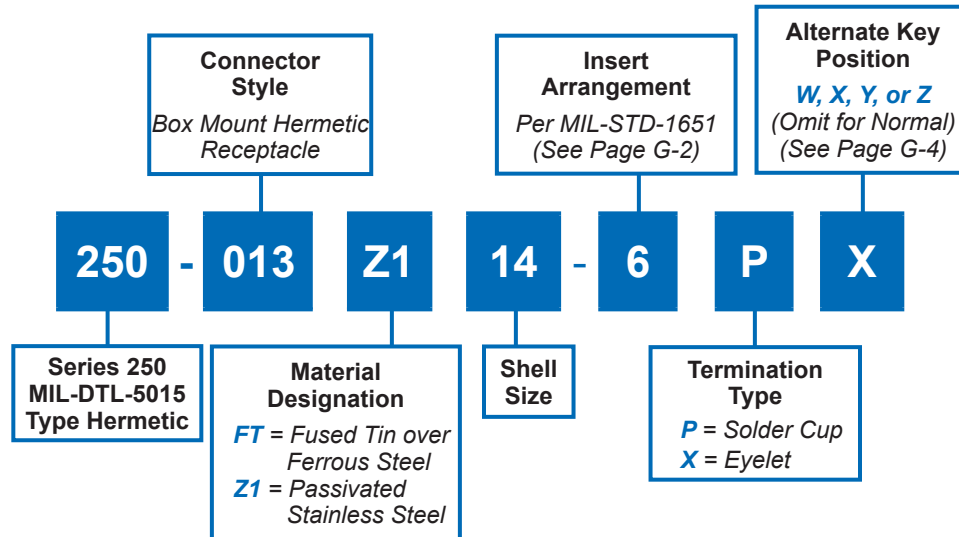

## APPLICATION NOTES

- To be identified with manufacturer's name, part number and date code, space permitting.
- Front panel mount square flange receptacle with through mounting holes.
- Material/Finish:  
Shell\* - Fused tin over ferrous steel/Z1 passivated stainless steel.  
Contacts - 52 Nickel alloy/gold plate  
Seals - Silicone elastomer/N.A.  
Insulation - Glass beads, NOIBN/N.A.
- Glenair 250-013 will mate with any MIL-DTL-5015 Series threaded coupling plug of same size and insert polarization.
- Performance:  
Hermeticity -  $<1 \times 10^{-7}$  cc/Sec @ 1 Atm. differential.  
Dielectric Withstanding Voltage - See Table II.  
Insulation Resistance - 5000 Megohms min @ 500VDC.
- Metric Dimensions (mm) are indicated in parentheses.

\* Additional shell materials available, including titanium and Inconel®. Consult factory for ordering information.

Dimensions in Inches (millimeters) are subject to change without notice.

**250-013**  
**MIL-DTL-5015 Type Hermetic**  
**Threaded Coupling Box Mount Receptacle Connector**  
**MS3142 Type**



MIL-DTL-5015  
Type

**TABLE I: CONTACT DIMENSIONS**

Contact Size	X Max	Y Max	Z Min	V Min	W Max
16	.219 (5.6)	.375 (9.5)	.020 (0.5)	.065 (1.7)	.115 (2.9)
12	.281 (7.1)	.516 (13.1)	.020 (0.5)	.096 (2.4)	.190 (4.8)
8	.700 (17.8)	.719 (18.3)	.040 (1.0)	.135 (3.4)	.330 (8.4)
4	.900 (22.9)	.980 (24.9)	.050 (1.3)	.220 (5.6)	.440 (11.2)
0	.900 (22.9)	.980 (24.9)	.090 (2.3)	.335 (8.5)	.605 (15.4)

Note: Contact sizes 4 and 0 are not available for "S" size shells (8S, 10S, 10SL, 12S, 14S, and 16S) and size 12 and 14

**TABLE II: SERVICE RATING**

Service Rating	Working Voltage (Volts RMS)
INST	200
A	500
D	900
E	1250
B	1750
C	3000

**HERMETIC LEAK RATE MOD CODES**

Designator	Required Leak Rate
-585A	1 x 10 <sup>-10</sup> cc Helium per second
-585B	1 x 10 <sup>-9</sup> cc Helium per second
-585C	1 x 10 <sup>-8</sup> cc Helium per second

**TABLE III: CONNECTOR DIMENSIONS**

Size	L Maximum Contact Size		ØN + .000 -.062 (+ 0 -1.6)	ØO (Ref) Mounting Hole	R T.P C — C	S ±.031 (0.8)	ØT ±.005 (0.1)
	16, 12, 8	4, 0					
	8S	.730 (18.5)					
10S	.730 (18.5)	-	.656 (16.7)	.688 (17.5)	.719 (18.3)	1.000 (25.4)	.120 (3.0)
10SL	.730 (18.5)	-	.656 (16.7)	.688 (17.5)	.719 (18.3)	1.000 (25.4)	.120 (3.0)
12S	.730 (18.5)	-	.782 (19.9)	.812 (20.6)	.812 (20.6)	1.094 (27.8)	.120 (3.0)
12	.915 (23.2)	-	.782 (19.9)	.812 (20.6)	.812 (20.6)	1.094 (27.8)	.120 (3.0)
14S	.730 (18.5)	-	.906 (23.0)	.938 (23.8)	.906 (23.0)	1.188 (30.2)	.120 (3.0)
14	.915 (23.2)	-	.906 (23.0)	.938 (23.8)	.906 (23.0)	1.188 (30.2)	.120 (3.0)
16S	.730 (18.5)	1.040 (26.4)	1.032 (26.2)	1.062 (27.0)	.969 (24.6)	1.281 (32.5)	.120 (3.0)
16	.915 (23.2)	1.040 (26.4)	1.032 (26.2)	1.062 (27.0)	.969 (24.6)	1.281 (32.5)	.120 (3.0)
18	.915 (23.2)	1.040 (26.4)	1.156 (29.4)	1.188 (30.2)	1.062 (27.0)	1.375 (34.9)	.120 (3.0)
20	.915 (23.2)	1.040 (26.4)	1.282 (32.6)	1.312 (33.3)	1.156 (29.4)	1.500 (38.1)	.120 (3.0)
22	.915 (23.2)	1.040 (26.4)	1.406 (35.7)	1.483 (36.5)	1.250 (31.8)	1.625 (41.3)	.120 (3.0)
24	.915 (23.2)	1.040 (26.4)	1.532 (38.9)	1.562 (39.7)	1.375 (34.9)	1.750 (44.5)	.147 (3.7)
28	.915 (23.2)	1.040 (26.4)	1.782 (45.3)	1.812 (46.0)	1.562 (39.7)	2.000 (50.8)	.147 (3.7)
32	.915 (23.2)	1.040 (26.4)	2.032 (51.6)	2.062 (52.4)	1.750 (44.5)	2.250 (57.2)	.173 (4.4)
36	.915 (23.2)	1.040 (26.4)	2.282 (58.0)	2.312 (58.7)	1.938 (49.2)	2.500 (63.5)	.173 (4.4)
40	.915 (23.2)	1.040 (26.4)	2.532 (64.3)	2.562 (65.1)	2.188 (55.6)	2.750 (69.9)	.173 (4.4)
44	.915 (23.2)	1.040 (26.4)	2.782 (70.7)	2.812 (71.4)	2.375 (60.3)	3.000 (76.2)	.173 (4.4)
48	.915 (23.2)	1.040 (26.4)	3.032 (77.0)	3.062 (77.8)	2.625 (66.7)	3.250 (82.6)	.173 (4.4)

Dimensions in Inches (millimeters) are subject to change without notice.



# 250-014 MIL-DTL-5015 Type Hermetic Threaded Coupling Solder Mount Receptacle Connector MS3143 Type

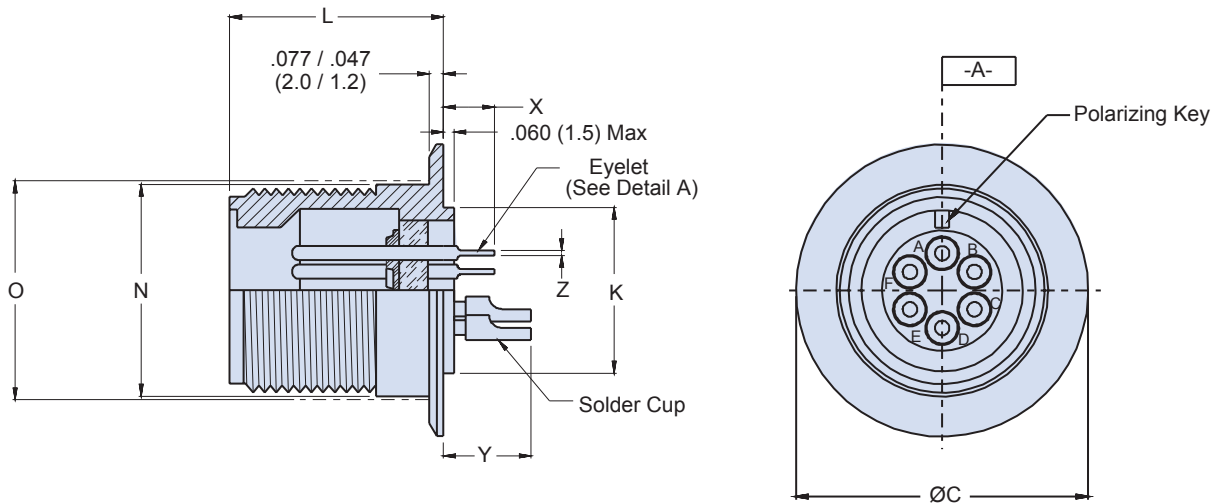
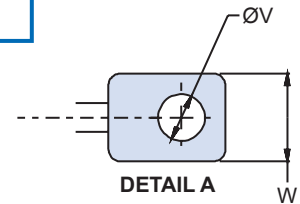
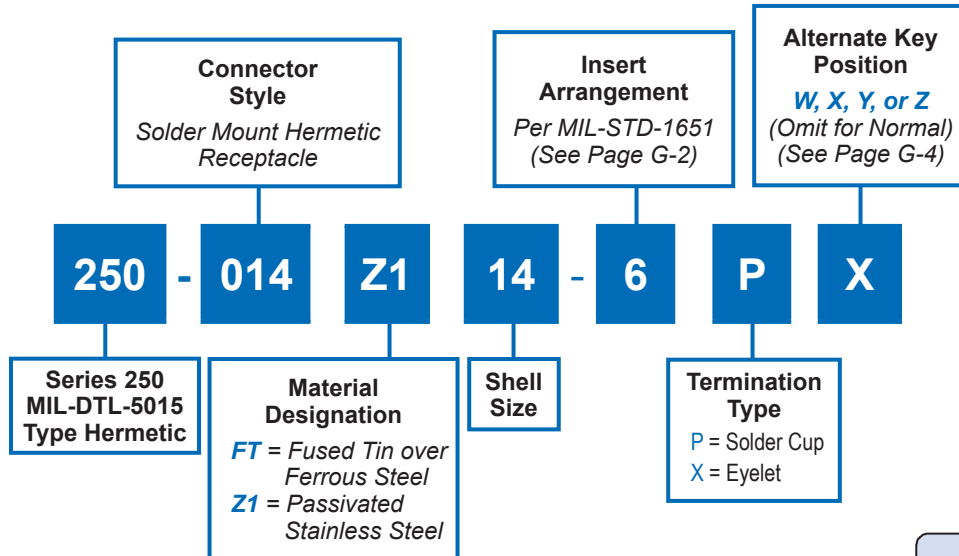

## APPLICATION NOTES

- To be identified with manufacturer's name, part number and date code, space permitting.
- Front panel mount square flange receptacle with through mounting holes.
- Material/Finish:  
Shell\* - Fused tin over ferrous steel; Z1 passivated stainless steel; Nickel Plated Stainless Steel  
Contacts - 52 Nickel alloy/gold plate  
Seals - Silicone elastomer/N.A.  
Insulation - Glass beads, NOIBN/N.A.
- Glenair 250-014 will mate with any MIL-DTL-5015 Series threaded coupling plug of same size and insert polarization.
- Performance:  
Hermeticity -  $<1 \times 10^{-7}$  cc/Sec @ 1 ATM differential.  
Dielectric Withstanding Voltage - See Table II.  
Insulation Resistance - 5000 Megohms min @ 500VDC.
- Metric Dimensions (mm) are indicated in parentheses.

\* Additional shell materials available, including titanium and Inconel®. Consult factory for ordering information.

Dimensions in Inches (millimeters) are subject to change without notice.

**250-014**  
**MIL-DTL-5015 Type Hermetic**  
**Threaded Coupling Solder Mount Receptacle Connector**  
**MS3143 Type**



MIL-DTL-5015  
Type

**TABLE I: CONTACT DIMENSIONS**

Contact Size	X Max	Y Max	Z Min	V Min	W Max
16	.219 (5.6)	.375 (9.5)	.020 (0.5)	.065 (1.7)	.115 (2.9)
12	.281 (7.1)	.516 (13.1)	.020 (0.5)	.096 (2.4)	.190 (4.8)
8	.700 (17.8)	.719 (18.3)	.040 (1.0)	.135 (3.4)	.330 (8.4)
4	.900 (22.9)	.980 (24.9)	.050 (1.3)	.220 (5.6)	.440 (11.2)
0	.900 (22.9)	.980 (24.9)	.090 (2.3)	.335 (8.5)	.605 (15.4)

Note: Contact sizes 4 and 0 are not available for "S" size shells (8S, 10S, 10SL, 12S, 14S, and 16S) and size 12 and 14

**HERMETIC LEAK RATE MOD CODES**

Designator	Required Leak Rate
-585A	1 x 10 <sup>-10</sup> cc Helium per second
-585B	1 x 10 <sup>-9</sup> cc Helium per second
-585C	1 x 10 <sup>-8</sup> cc Helium per second

**TABLE II: SERVICE RATING**

Service Rating	Working Voltage (Volts RMS)
INST	200
A	500
D	900
E	1250
B	1750
C	3000

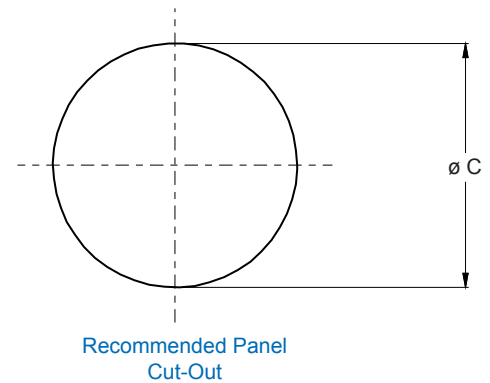

**TABLE III: CONNECTOR DIMENSIONS**

Size	C Dia $\pm 0.010$ (0.25)	K Dia $\pm 0.010$ (0.25)	L Max		N Dia +.000 -.062 (+.000 -.1.6)	O Dia (Ref) Mtg Hole
			Contact Size			
			16, 12 & 8	4 & 0		
8S	.750 (19.1)	.428 (10.9)	.730 (18.5)	-	.532 (13.5)	.562 (14.3)
10S	.875 (22.2)	.490 (12.4)	.730 (18.5)	-	.656 (16.7)	.688 (17.5)
10SL	.875 (22.2)	.490 (12.4)	.730 (18.5)	-	.656 (16.7)	.688 (17.5)
12S	1.000 (25.4)	.646 (16.4)	.730 (18.5)	-	.782 (19.9)	.812 (20.6)
12	1.000 (25.4)	.646 (16.4)	.915 (23.2)	-	.782 (19.9)	.812 (20.6)
14S	1.125 (28.6)	.709 (18.0)	.730 (18.5)	-	.906 (23.0)	.938 (23.8)
14	1.125 (28.6)	.709 (18.0)	.915 (23.2)	-	.906 (23.0)	.938 (23.8)
16S	1.250 (31.8)	.834 (21.2)	.730 (18.5)	1.040 (26.4)	1.032 (26.2)	1.062 (27.0)
16	1.250 (31.8)	.834 (21.2)	.834 (21.2)	1.040 (26.4)	1.032 (26.2)	1.062 (27.0)
18	1.375 (34.9)	.959 (24.4)	.915 (23.2)	1.040 (26.4)	1.156 (29.4)	1.188 (30.2)
20	1.500 (38.1)	1.146 (29.1)	.915 (23.2)	1.040 (26.4)	1.282 (32.6)	1.312 (33.3)
22	1.625 (41.3)	1.240 (31.5)	.915 (23.2)	1.040 (26.4)	1.406 (35.7)	1.438 (36.5)
24	1.750 (44.5)	1.365 (34.7)	.915 (23.2)	1.040 (26.4)	1.532 (38.9)	1.562 (39.7)
28	2.000 (50.8)	1.615 (41.0)	.915 (23.2)	1.040 (26.4)	1.782 (45.3)	1.812 (46.0)
32	2.250 (57.2)	1.865 (47.4)	.915 (23.2)	1.040 (26.4)	2.032 (51.6)	1.062 (27.0)
36	2.500 (63.5)	2.115 (53.7)	.915 (23.2)	1.040 (26.4)	2.282 (58.0)	2.500 (63.5)
40	2.750 (69.9)	2.365 (60.1)	.915 (23.2)	1.040 (26.4)	2.532 (64.3)	2.750 (69.9)
44	3.000 (76.2)	2.615 (66.4)	.915 (23.2)	1.040 (26.4)	2.782 (70.7)	3.000 (76.2)
48	3.250 (82.6)	2.865 (72.8)	.915 (23.2)	1.040 (26.4)	3.032 (77.0)	3.250 (82.6)

Dimensions in Inches (millimeters) are subject to change without notice.

# 250-015 MIL-DTL-5015 Type Hermetic Threaded Coupling Box Mount Receptacle Connector MS3142 Type

G

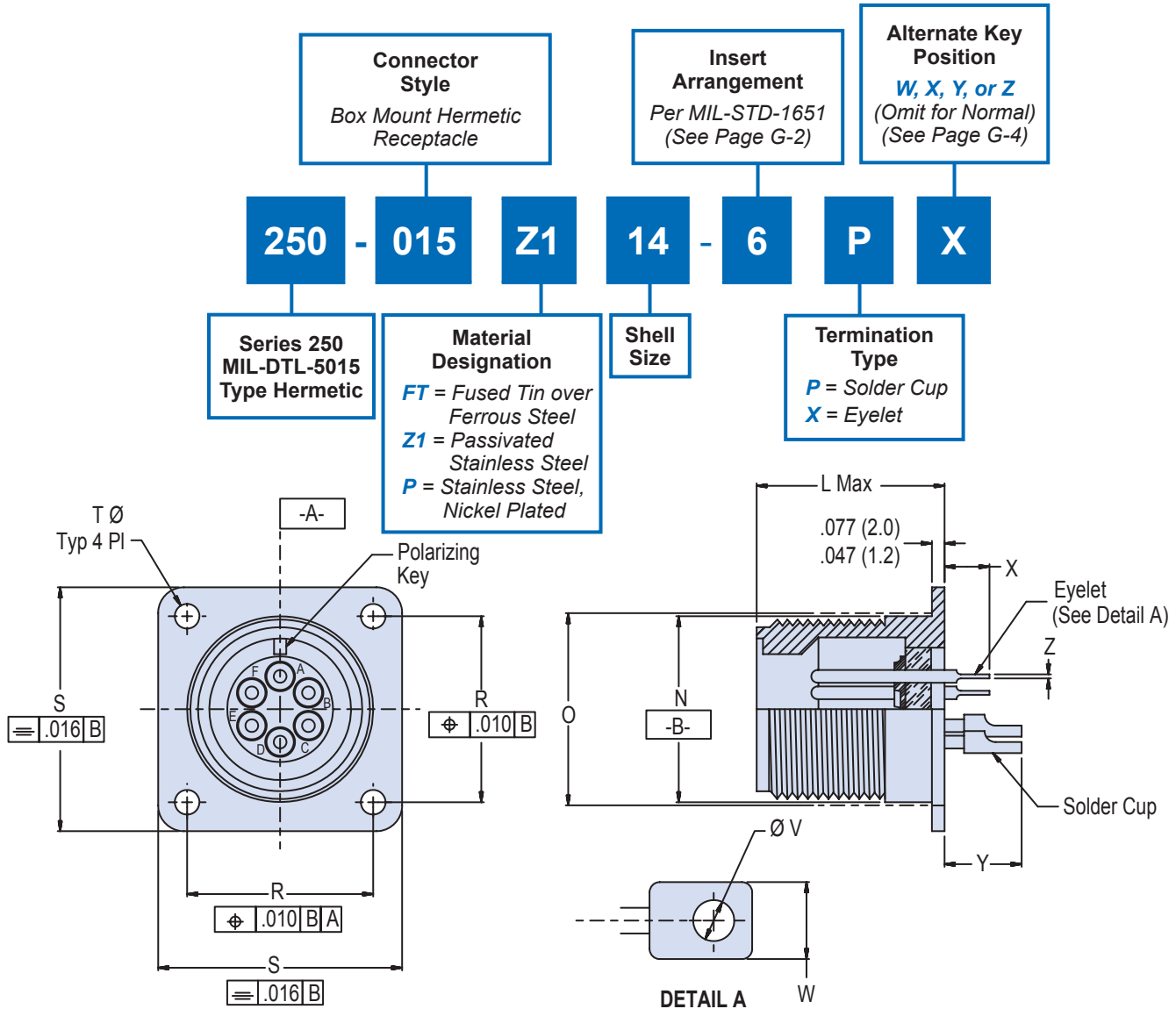

## APPLICATION NOTES

- Material/Finish:  
Shell: FT - Fused Tin over Carbon Steel  
Z1 - Passivated Stainless Steel  
P - Stainless Steel, Nickel Plated
- Assembly to be identified with Glenair's name, part number and date code, space permitting.
- Performance:  
Hermeticity -  $<1 \times 10^{-7}$  cca/Sec @ 1 atmosphere differential.  
Dielectric Withstanding Voltage - See Table II.  
Insulation Resistance - 5000 Megohms minimum @ 500VDC.
- Glenair 250-015 will mate with any MIL-DTL-5015 threaded coupling plug of same size and insert polarization.
- Metric dimensions (mm) are in parenthesis.

Dimensions in Inches (millimeters) are subject to change without notice.

**250-015**  
**MIL-DTL-5015 Type Hermetic**  
**Threaded Coupling Box Mount Receptacle Connector**  
**MS3142 Type**



MIL-DTL-5015  
Type

**TABLE I: CONTACT DIMENSIONS**

Contact Size	X Max	Y Max	Z Min	V Min	W Max
16	.219 (5.6)	.375 (9.5)	.020 (0.5)	.065 (1.7)	.115 (2.9)
12	.281 (7.1)	.516 (13.1)	.020 (0.5)	.096 (2.4)	.190 (4.8)
8	.700 (17.8)	.719 (18.3)	.040 (1.0)	.135 (3.4)	.330 (8.4)
4	.900 (22.9)	.980 (24.9)	.050 (1.3)	.220 (5.6)	.440 (11.2)
0	.900 (22.9)	.980 (24.9)	.090 (2.3)	.335 (8.5)	.605 (15.4)

Note: Contact sizes 4 and 0 are not available for "S" size shells (8S, 10S, 10SL, 12S, 14S, and 16S) and size 12 and 14

**TABLE II: SERVICE RATING**

Service Rating	Working Voltage (Volts RMS)
INST	200
A	500
D	900
E	1250
B	1750
C	3000

**HERMETIC LEAK RATE MOD CODES**

Designator	Required Leak Rate
-585A	1 x 10 <sup>-10</sup> cc Helium per second
-585B	1 x 10 <sup>-9</sup> cc Helium per second
-585C	1 x 10 <sup>-8</sup> cc Helium per second

**TABLE III: CONNECTOR DIMENSIONS**

Size	L Max		N Dia +.000 -.062 (+.000 -.1.6)	O Dia (Ref) Mtg Hole	R T.P C——C	S .031 (0.79)	T Dia ± .005 (0.13)
	Contact Size						
	16, 12 & 8	4 & 0					
8S	.730 (18.5)	-	.532 (13.5)	.562 (14.3)	.594 (15.1)	.875 (22.2)	.120 (3.0)
10S	.730 (18.5)	-	.656 (16.7)	.688 (17.5)	.719 (18.3)	1.000 (25.4)	.120 (3.0)
10SL	.730 (18.5)	-	.656 (16.7)	.688 (17.5)	.719 (18.3)	1.000 (25.4)	.120 (3.0)
12S	.730 (18.5)	-	.782 (19.9)	.812 (20.6)	.812 (20.6)	1.094 (27.8)	.120 (3.0)
12	.915 (23.2)	-	.782 (19.9)	.812 (20.6)	.812 (20.6)	1.094 (27.8)	.120 (3.0)
14S	.730 (18.5)	-	.906 (23.0)	.938 (23.8)	.906 (23.0)	1.188 (30.2)	.120 (3.0)
14	.915 (23.2)	-	.906 (23.0)	.938 (23.8)	.906 (23.0)	1.188 (30.2)	.120 (3.0)
16S	.730 (18.5)	1.040 (26.4)	1.032 (26.2)	1.062 (27.0)	.969 (24.6)	1.281 (32.5)	.120 (3.0)
16	.915 (23.2)	1.040 (26.4)	1.032 (26.2)	1.062 (27.0)	.969 (24.6)	1.281 (32.5)	.120 (3.0)
18	.915 (23.2)	1.040 (26.4)	1.156 (29.4)	1.188 (30.2)	1.062 (27.0)	1.375 (34.9)	.120 (3.0)
20	.915 (23.2)	1.040 (26.4)	1.282 (32.6)	1.312 (33.3)	1.156 (29.4)	1.500 (38.1)	.120 (3.0)
22	.915 (23.2)	1.040 (26.4)	1.406 (35.7)	1.438 (36.5)	1.250 (31.8)	1.625 (41.3)	.120 (3.0)
24	.915 (23.2)	1.040 (26.4)	1.532 (38.9)	1.562 (39.7)	1.375 (34.9)	1.750 (44.5)	.147 (3.7)
28	.915 (23.2)	1.040 (26.4)	1.782 (45.3)	1.812 (46.0)	1.562 (39.7)	2.000 (50.8)	.147 (3.7)
32	.915 (23.2)	1.040 (26.4)	2.032 (51.6)	2.062 (52.3)	1.750 (44.5)	2.250 (57.2)	.173 (4.4)
36	.915 (23.2)	1.040 (26.4)	2.282 (58.0)	2.312 (58.7)	1.938 (49.2)	2.500 (63.5)	.173 (4.4)
40	.915 (23.2)	1.040 (26.4)	2.532 (64.3)	2.562 (65.1)	2.188 (55.6)	2.750 (69.9)	.173 (4.4)
44	.915 (23.2)	1.040 (26.4)	2.782 (70.7)	2.812 (71.4)	2.375 (60.3)	3.000 (76.2)	.173 (4.4)
48	.915 (23.2)	1.040 (26.4)	3.032 (77.0)	3.062 (77.8)	2.625 (66.7)	3.250 (82.6)	.173 (4.4)

Dimensions in Inches (millimeters) are subject to change without notice.

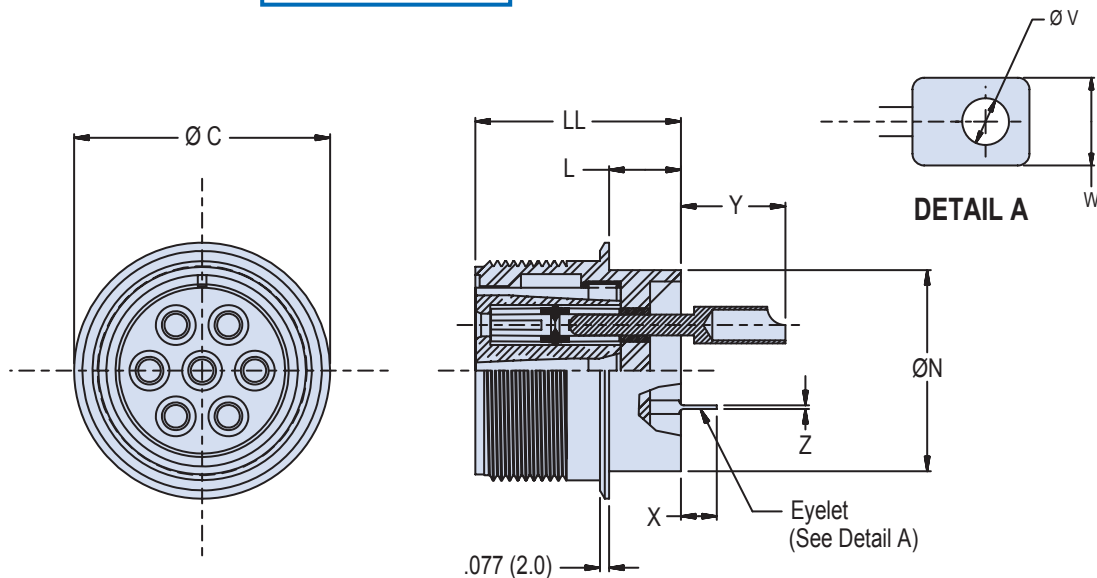
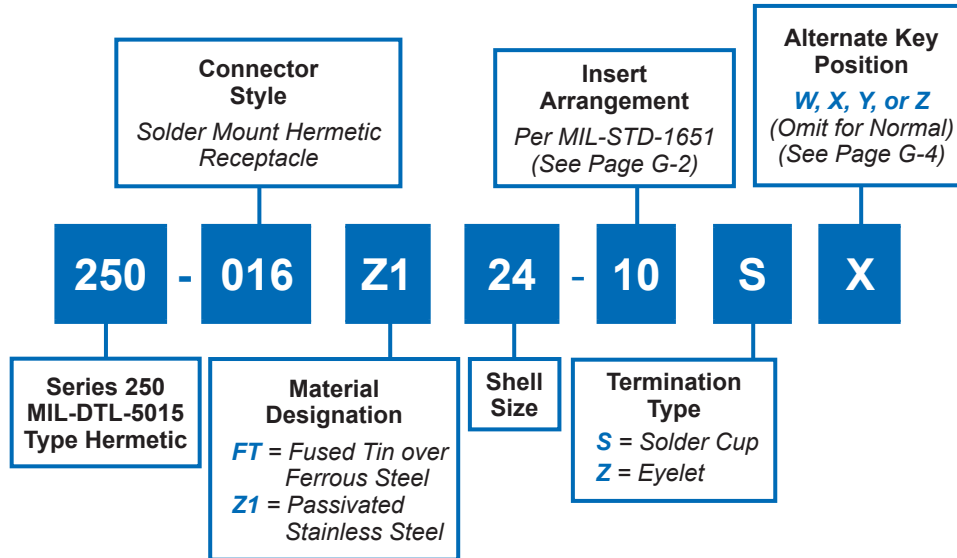
**APPLICATION NOTES**

- Material/Finish:  
Shell: FT - Fused Tin over Carbon Steel  
Z1 - Passivated Stainless Steel  
Contacts - 52 Nickel Alloy/Gold Plate  
Sockets - Copper Alloy/Gold Plate  
Insulator - Glass/N.A.  
Socket Insulator - Rigid Dielectric/N.A.
- Assembly to be identified with Glenair's name, part number and date code, space permitting.
- Performance:  
Hermeticity -  $<1 \times 10^{-7}$  cc/Sec @ 1 atmosphere differential.  
Dielectric Withstanding Voltage - See Table II.  
Insulation Resistance - 5000 Megohms minimum @ 500VDC.
- Glenair 250-016 will mate with any MIL-DTL-5015 threaded coupling plug of same size and insert polarization.
- Metric dimensions (mm) are in parenthesis.

Dimensions in Inches (millimeters) are subject to change without notice.

**250-016**  
**MIL-DTL-5015 Type Hermetic**  
**Threaded Coupling Solder Mount Receptacle Connector**  
**MS3143 Type Sockets**

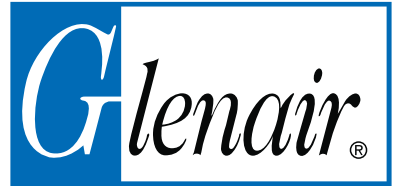

MIL-DTL-5015  
Type

**TABLE I: CONTACT DIMENSIONS**

Contact Size	X Max	Y Max	Z Min	V Min	W Max
16	.219 (5.6)	.375 (9.5)	.020 (0.5)	.065 (1.7)	.115 (2.9)
12	.281 (7.1)	.516 (13.1)	.020 (0.5)	.096 (2.4)	.190 (4.8)
8	.700 (17.8)	.719 (18.3)	.040 (1.0)	.135 (3.4)	.330 (8.4)
4	.900 (22.9)	.980 (24.9)	.050 (1.3)	.220 (5.6)	.440 (11.2)
0	.900 (22.9)	.980 (24.9)	.090 (2.3)	.335 (8.5)	.605 (15.4)

Note: Contact sizes 4 and 0 are not available for "S" size shells (8S, 10S, 10SL, 12S, 14S, and 16S) and size 12 and 14

**TABLE II: SERVICE RATING**

Service Rating	Working Voltage (Volts RMS)
INST	200
A	500
D	900
E	1250
B	1750
C	3000

**HERMETIC LEAK RATE MOD CODES**

Designator	Required Leak Rate
-585A	1 x 10 <sup>-10</sup> cc Helium per second
-585B	1 x 10 <sup>-9</sup> cc Helium per second
-585C	1 x 10 <sup>-8</sup> cc Helium per second

**TABLE III: CONNECTOR DIMENSIONS**

Size	C Dia ± .010 (0.3)	L ± .010 (0.3)	LL Max	N Dia + .000 - .062	O Dia (Ref) Mtg Hole
12S	1.000 (25.4)	.438 (11.1)	1.094 (27.8)	.782 (19.9)	.812 (20.6)
12	1.000 (25.4)	.438 (11.1)	1.282 (32.6)	.782 (19.9)	.812 (20.6)
14S	1.125 (28.6)	.438 (11.1)	1.094 (27.8)	.906 (23.0)	.938 (23.8)
14	1.125 (28.6)	.438 (11.1)	1.282 (32.6)	.906 (23.0)	.938 (23.8)
16S	1.250 (31.8)	.438 (11.1)	1.094 (27.8)	1.032 (26.2)	1.062 (27.0)
16	1.250 (31.8)	.438 (11.1)	1.282 (32.6)	1.032 (26.2)	1.062 (27.0)
18	1.375 (34.9)	.438 (11.1)	1.282 (32.6)	1.156 (29.4)	1.188 (30.2)
20	1.500 (38.1)	.438 (11.1)	1.282 (32.6)	1.282 (32.6)	1.312 (33.3)
22	1.625 (41.3)	.438 (11.1)	1.282 (32.6)	1.406 (35.7)	1.438 (36.5)
24	1.750 (44.5)	.563 (14.3)	1.406 (35.7)	1.532 (38.9)	1.562 (39.7)
28	2.000 (50.8)	.563 (14.3)	1.406 (35.7)	1.782 (45.3)	1.812 (46.0)
32	2.250 (57.2)	.563 (14.3)	1.406 (35.7)	2.032 (51.6)	2.062 (53.4)
36	2.500 (63.5)	.563 (14.3)	1.406 (35.7)	2.282 (58.0)	2.500 (63.5)
40	2.750 (69.9)	.563 (14.3)	1.406 (35.7)	2.532 (64.3)	2.750 (69.9)
44	3.000 (76.2)	.563 (14.3)	1.406 (35.7)	2.782 (70.7)	3.000 (76.2)
48	3.250 (82.6)	.563 (14.3)	1.406 (35.7)	3.032 (77.0)	3.250 (82.6)

Dimensions in Inches (millimeters) are subject to change without notice.

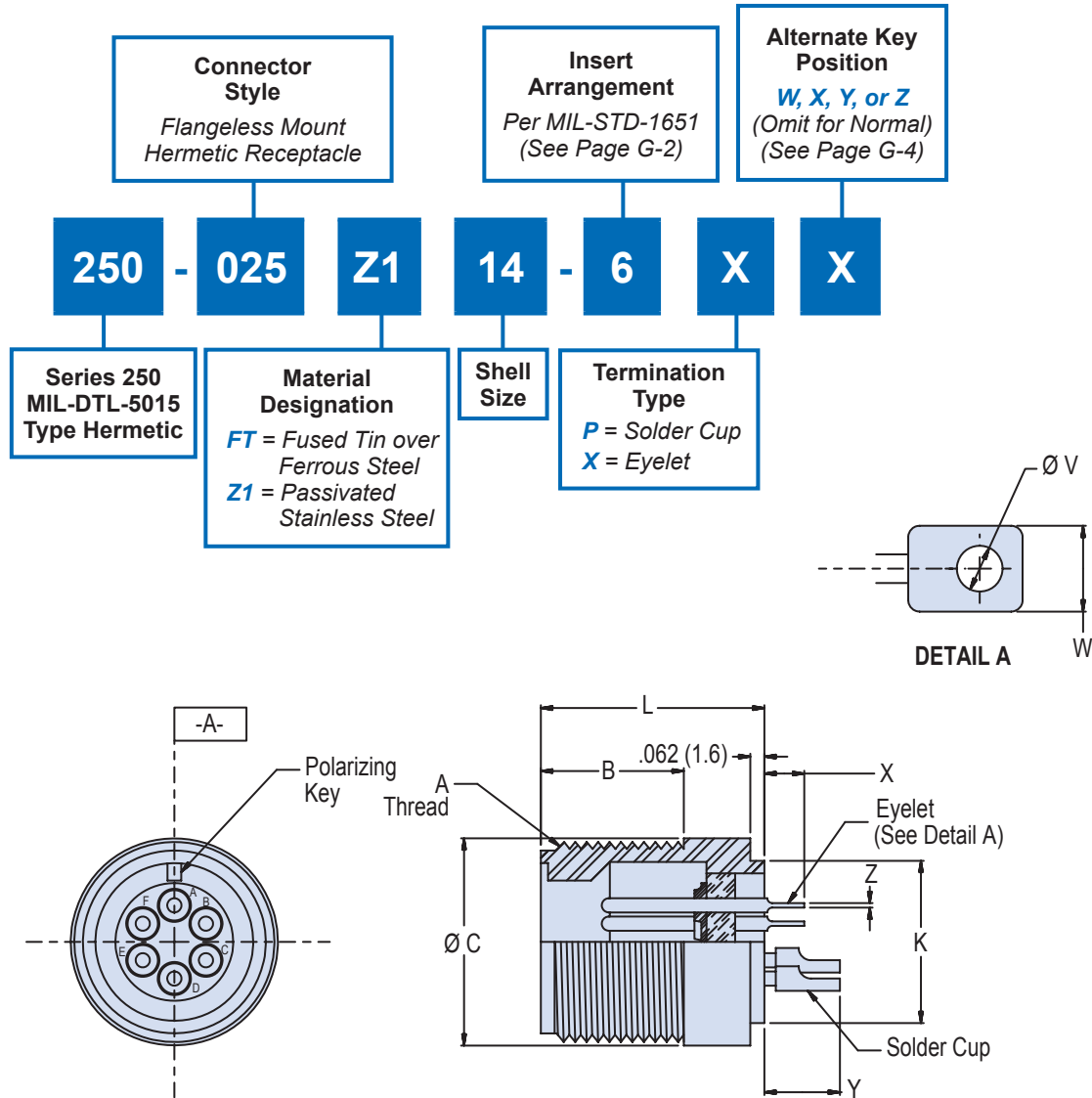

## APPLICATION NOTES

- Material/Finish:  
Shell: FT - Fused Tin over Carbon Steel  
Z1 - Passivated Stainless Steel  
Contacts - 52 Nickel Alloy/Gold Plate  
Seals - Silicone Elastomer/N.A.  
Insulator - Full Glass
- Assembly to be identified with Glenair's name, part number and date code, space permitting.
- Performance:  
Hermeticity -  $<1\_X10^{-7}$  cc/Sec @ 1 atmosphere differential.  
Dielectric Withstanding Voltage - See Table II.  
Insulation Resistance - 5000 Megohms minimum @ 500VDC.
- Glenair 250-016 will mate with any MIL-DTL-5015 threaded coupling plug of same size and insert polarization.
- Metric dimensions (mm) are in parenthesis.

Dimensions in Inches (millimeters) are subject to change without notice.



**250-025**  
**MIL-DTL-5015 Type Hermetic**  
**Threaded Coupling Flangeless Mount Receptacle Connector**  
**MS3143 Type**



MIL-DTL-5015  
Type

**TABLE I: CONTACT DIMENSIONS**

Contact Size	X Max	Y Max	Z Min	V Min	W Max
16	.219 (5.6)	.375 (9.5)	.020 (0.5)	.065 (1.7)	.115 (2.9)
12	.281 (7.1)	.516 (13.1)	.020 (0.5)	.096 (2.4)	.190 (4.8)
8	.700 (17.8)	.719 (18.3)	.040 (1.0)	.135 (3.4)	.330 (8.4)
4	.900 (22.9)	.980 (24.9)	.050 (1.3)	.220 (5.6)	.440 (11.2)
0	.900 (22.9)	.980 (24.9)	.090 (2.3)	.335 (8.5)	.605 (15.4)

Note: Contact sizes 4 and 0 are not available for "S" size shells (8S, 10S, 10SL, 12S, 14S, and 16S) and size 12 and 14

**TABLE II: SERVICE RATING**

Service Rating	Working Voltage (Volts RMS)
INST	200
A	500
D	900
E	1250
B	1750
C	3000

**HERMETIC LEAK RATE MOD CODES**

Designator	Required Leak Rate
-585A	1 x 10 <sup>-10</sup> cc Helium per second
-585B	1 x 10 <sup>-9</sup> cc Helium per second
-585C	1 x 10 <sup>-8</sup> cc Helium per second

**TABLE III: CONNECTOR DIMENSIONS**

Size	A Thread Class 2A	B Min Thread	C Dia ± .010 (0.3)	K Dia ± .010 (0.3)	L Max Contact Size	
					16, 12, 8	4 and 0
8S	.500-28 UNEF	.375 (9.5)	.500 (12.7)	.438 (11.1)	.730 (18.5)	—
10S	.625-24 UNEF	.375 (9.5)	.625 (15.9)	.500 (12.7)	.730 (18.5)	—
10SL	.625-24 UNEF	.375 (9.5)	.625 (15.9)	.500 (12.7)	.730 (18.5)	—
12S	.750-20 UNEF	.375 (9.5)	.750 (19.1)	.656 (16.7)	.730 (18.5)	—
12	.750-20 UNEF	.625 (15.9)	.750 (19.1)	.656 (16.7)	.915 (23.2)	—
14S	.875-20 UNEF	.375 (9.5)	.875 (22.2)	.719 (18.3)	.730 (18.5)	—
14	.875-20 UNEF	.625 (15.9)	.875 (22.2)	.719 (18.3)	.915 (23.2)	—
16S	1.000-20 UNEF	.375 (9.5)	1.000 (25.4)	.844 (21.4)	.730 (18.5)	1.040 (26.4)
16	1.000-20 UNEF	.625 (15.9)	1.000 (25.4)	.844 (21.4)	.915 (23.2)	1.040 (26.4)
18	1.125-18 UNEF	.625 (15.9)	1.125 (28.6)	.969 (24.6)	.915 (23.2)	1.040 (26.4)
20	1.250-18 UNEF	.625 (15.9)	1.250 (31.8)	1.156 (29.4)	.915 (23.2)	1.040 (26.4)
22	1.375-18 UNEF	.625 (15.9)	1.375 (34.9)	1.250 (31.8)	.915 (23.2)	1.040 (26.4)
24	1.500-18 UNEF	.625 (15.9)	1.500 (38.1)	1.375 (34.9)	.915 (23.2)	1.040 (26.4)
28	1.750-18 UNS	.625 (15.9)	1.750 (44.5)	1.625 (41.3)	.915 (23.2)	1.040 (26.4)
32	2.000-18 UNS	.625 (15.9)	2.000 (50.8)	1.875 (47.6)	.915 (23.2)	1.040 (26.4)
36	2.250-16 UN	.625 (15.9)	2.250 (57.2)	2.125 (54.0)	.915 (23.2)	1.040 (26.4)
40	2.500-16 UN	.625 (15.9)	2.500 (63.5)	2.375 (60.3)	.915 (23.2)	1.040 (26.4)
44	2.750-16 UN	.625 (15.9)	2.750 (69.9)	2.625 (66.7)	.915 (23.2)	1.040 (26.4)
48	3.000-16 UN	.625 (15.9)	3.000 (76.2)	2.875 (73.0)	.915 (23.2)	1.040 (26.4)

Dimensions in Inches (millimeters) are subject to change without notice.

**Connector Style**  
Jam Nut Mount Hermetic Receptacle

**Insert Arrangement**  
Per MIL-STD-1651  
(See Page G-2)

**Alternate Key Position**  
*W, X, Y, or Z*  
(Omit for Normal)  
(See Page G-4)

**257****- 384****Z1****14****- 6****C****X****V**

**Series 257  
MIL-DTL-5015  
Type Hermetic**

**Material Designation**

*FT = Fused Tin over Ferrous Steel*  
*Z1 = Passivated Stainless Steel*  
*ZL = Nickel Plated Stainless Steel*

**Shell Size**

**Termination Type**

*P = Solder Cup*  
*C = PC Tail*

**O-Ring Material**  
(See Table III)

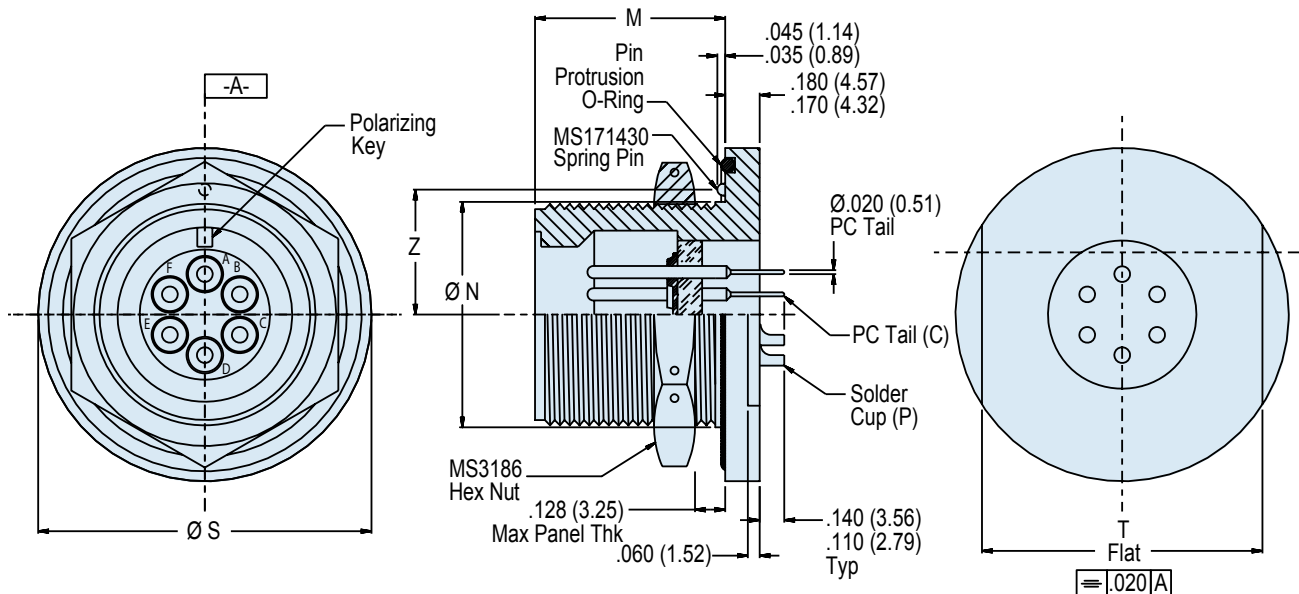

#### APPLICATION NOTES

- Material/Finish:  
Shell - FT - Fused tin over Carbon steel  
Z1 - Passivated stainless steel  
ZL - Nickel plated stainless steel  
Contacts - 52 Nickel alloy/Gold plate  
Seals - Fluorosilicone elastomer/N.A.  
Insulator - Full vitreous glass  
O-Ring - Specify per Table III
- Assembly to be identified with Glenair's name, part number and date code, space permitting.
- Performance:  
Hermeticity -  $<1 \times 10^{-7}$  cc/Sec @ 1 atmosphere differential.  
Dielectric Withstanding Voltage - See Table II.  
Insulation Resistance - 5000 Megohms minimum @ 500VDC.
- Glenair 257-384 will mate with any MIL-DTL-5015 threaded coupling plug of same size and insert polarization.
- Metric dimensions (mm) are in parenthesis.

Dimensions in Inches (millimeters) are subject to change without notice.

**257-384**  
**MIL-DTL-5015 Type Hermetic**  
**Jam Nut Mount Mount Receptacle Connector**  
**MS3404 Type**



MIL-DTL-5015  
Type

**TABLE I: CONNECTOR DIMENSIONS**

Size	M ± .005 (0.1)	Ø N +.000 -.005 (+0.0 -0.1)	Ø O +.015 -.000 (+0.4 -0.0)	Ø S ± .005 (0.1)	T ± .010 (0.3) Flats	Z ± .005 (0.1)
8S	.720 (9.5)	.500 (12.7)	.505 (12.8)	1.072 (27.2)	.865 (22.0)	.326 (8.3)
10S	.720 (9.5)	.625 (15.9)	.630 (16.0)	1.193 (30.3)	.990 (25.1)	.385 (9.8)
10SL	.720 (9.5)	.625 (15.9)	.630 (16.0)	1.193 (30.3)	.990 (25.1)	.385 (9.8)
12S	.720 (9.5)	.750 (19.1)	.755 (19.2)	1.317 (33.5)	1.050 (26.7)	.448 (11.4)
12	.966 (24.5)	.750 (19.1)	.755 (19.2)	1.317 (33.5)	1.050 (26.7)	.448 (11.4)
14S	.720 (9.5)	.875 (22.2)	.880 (22.4)	1.443 (36.7)	1.175 (29.8)	.510 (13.0)
14	.966 (24.5)	.875 (22.2)	.880 (22.4)	1.443 (36.7)	1.175 (29.8)	.510 (13.0)
16S	.720 (9.5)	1.000 (25.4)	1.005 (25.5)	1.567 (39.8)	1.300 (33.0)	.573 (14.6)
16	.966 (24.5)	1.000 (25.4)	1.005 (25.5)	1.567 (39.8)	1.300 (33.0)	.573 (14.6)
18	.966 (24.5)	1.125 (28.6)	1.130 (28.7)	1.693 (43.0)	1.425 (36.2)	.635 (16.1)
20	.966 (24.5)	1.250 (31.8)	1.255 (31.9)	1.817 (46.2)	1.550 (39.4)	.698 (17.7)
22	.966 (24.5)	1.375 (34.9)	1.380 (35.1)	1.943 (49.4)	1.550 (39.4)	.760 (19.3)
24	.966 (24.5)	1.500 (38.1)	1.505 (38.2)	2.067 (52.5)	1.800 (45.7)	.823 (20.9)
28	.966 (24.5)	1.750 (44.5)	1.755 (44.6)	2.317 (58.9)	1.925 (48.9)	.948 (24.1)
32	.966 (24.5)	2.000 (50.8)	2.005 (50.9)	2.567 (65.2)	2.175 (55.2)	1.073 (27.3)
36	.966 (24.5)	2.250 (57.2)	2.255 (57.3)	2.817 (71.6)	2.550 (64.8)	1.198 (30.4)
40	.966 (24.5)	2.500 (63.5)	2.505 (63.6)	3.061 (77.7)	2.800 (71.1)	1.323 (33.6)
44	.966 (24.5)	2.750 (69.9)	2.755 (70.0)	3.311 (84.1)	3.050 (77.5)	1.448 (36.8)
48	.966 (24.5)	3.000 (76.2)	3.005 (76.3)	3.561 (90.4)	3.300 (83.8)	1.573 (40.0)

**TABLE II:  
SERVICE RATING**

Service Rating	Test Voltages (Sea-Level) (Volts-RMS)	Working Voltage (Sea-Level) (Volts RMS)
INST	1000	200
A	2000	500
D	2800	900
E	3500	1250
B	4500	1750
C	7000	3000

**TABLE III: O-RINGS**

Sym	Material
F	Fluorosilicone (Non-Conductive)
E	EPDM (Ethylene-Propylene)
V	Viton (Fluorocarbon, FKM)
N	Nitrile (Buna-N, NBR)
S	Silicone (ZZ-R-765)
B	Butyl Rubber (IIR)
K	Kalrez (FFKM)

**HERMETIC LEAK RATE MOD CODES**

Designator	Required Leak Rate
-585A	1 x 10 <sup>-10</sup> cc Helium per second
-585B	1 x 10 <sup>-9</sup> cc Helium per second
-585C	1 x 10 <sup>-8</sup> cc Helium per second

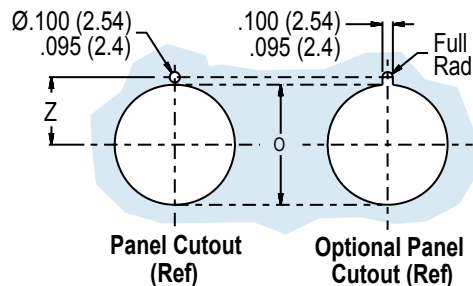

Dimensions in Inches (millimeters) are subject to change without notice.

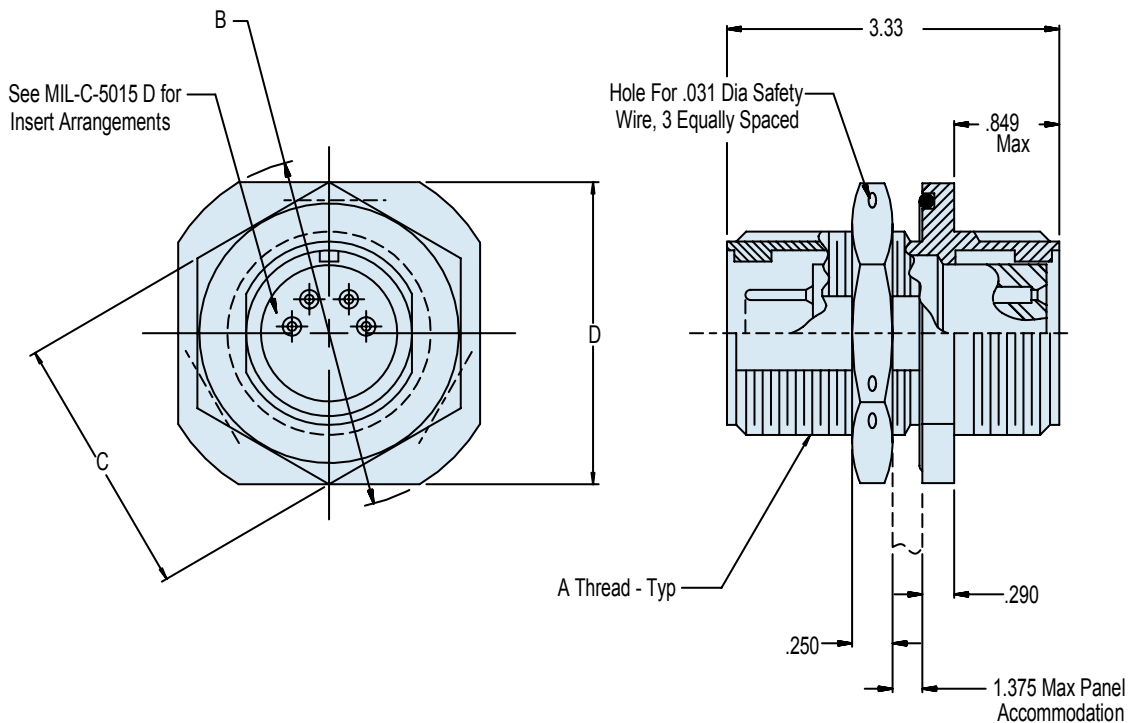
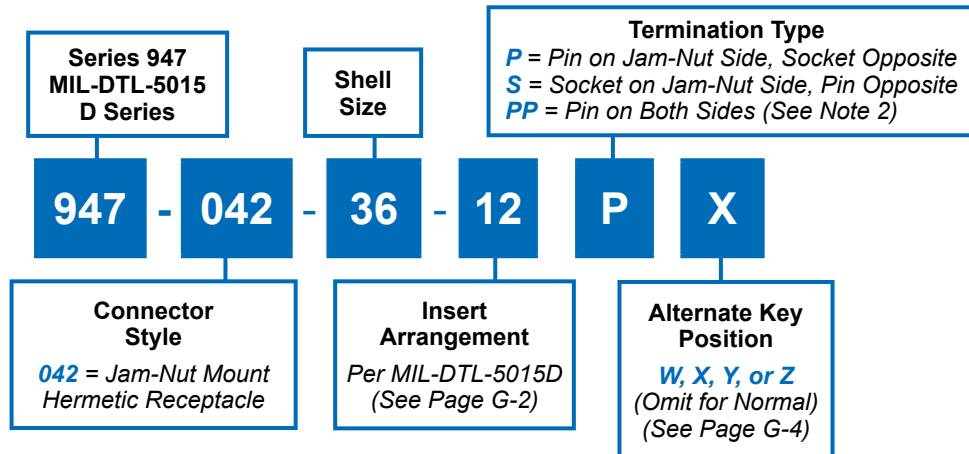

#### APPLICATION NOTES

- |  |  |
|--|--|
| <p>1. Material/Finish:<br/>Jam-nut, hoods, lock-ring, shell* - Stainless steel/passivated.<br/>Contacts - Alloy 52/gold plated.<br/>Insulators - High-grade rigid dielectric, full glass or glass bead.<br/>O-Rings - Silicone/N.A.</p> <p>2. For pin-to-pin, symmetrical layouts only. Power to a given contact on one end will result in power to contact directly opposite regardless of identification letter.</p> | <p>3. Hermeticity - Less than <math>1 \times 10^{-7}</math> cc/sec at one atmosphere. Not for use in liquid atmosphere. Connector rated to 200° C and 1000 PSI max.</p> <p>4. Outgas for space application.</p> <p>5. To be identified with manufacturer's name, part number and date code, space permitting.</p> <p>6. Metric Dimensions (mm) are indicated in parentheses.</p> |
|--|--|

\* Additional shell materials available, including titanium and Inconel®. Consult factory for ordering information.

Dimensions in Inches (millimeters) are subject to change without notice.

947-042

**MIL-DTL-5015 Type Hermetic**  
**Jam Nut Mount Bulkhead Feed-Through D Series Connector**  
**with Pin/Socket Contacts**



MIL-DTL-5015  
Type

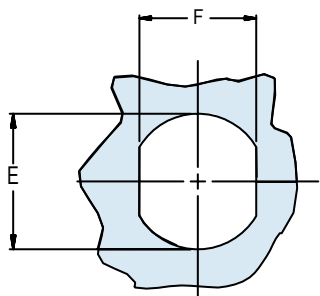

RECOMMENDED PANEL CUT-OUT

HERMETIC LEAK RATE MOD CODES	
Designator	Required Leak Rate
-585A	1 x 10 <sup>-10</sup> cc Helium per second
-585B	1 x 10 <sup>-9</sup> cc Helium per second
-585C	1 x 10 <sup>-8</sup> cc Helium per second

G

TABLE I: CONNECTOR AND CUT-OUT DIMENSIONS

Shell Size	A Thread Class 2A	B Dia Max	C Hex	D Flats	E Dia ± .005 (0.1)	F + .005 -.000 (+0.1 - 0.0)
08	1/2-28 UNEF	1.000 (25.4)	.688 (17.5)	.875 (22.2)	.510 (13.0)	.460 (11.7)
10	5/8-24 UNEF	1.125 (28.6)	.812 (20.6)	1.000 (25.4)	.635 (16.1)	.578 (14.7)
12	3/4-20 UNEF	1.250 (31.8)	.938 (23.8)	1.125 (28.6)	.760 (19.3)	.692 (17.6)
14	7/8-20 UNEF	1.375 (34.9)	1.062 (27.0)	1.250 (31.8)	.885 (22.5)	.817 (20.8)
16	1-20 UNEF	1.500 (38.1)	1.250 (31.8)	1.375 (34.9)	1.010 (25.7)	.942 (23.9)
18	1 1/8-18 UNEF	1.750 (44.5)	1.375 (34.9)	1.625 (41.3)	1.135 (28.8)	1.060 (26.9)
20	1 1/4-18 UNEF	1.875 (47.6)	1.500 (38.1)	1.750 (44.5)	1.260 (32.0)	1.185 (30.1)
22	1 3/8-18 UNEF	2.000 (50.8)	1.625 (41.3)	1.875 (47.6)	1.385 (35.2)	1.310 (33.3)
24	1 1/2-18 UNEF	2.188 (55.6)	1.750 (44.5)	2.000 (50.8)	1.510 (38.4)	1.435 (36.4)
28	1 3/4-18 UNEF	2.438 (61.9)	2.000 (50.8)	2.250 (57.2)	1.760 (44.7)	1.687 (42.8)
32	2-18 UNEF	2.688 (68.3)	2.250 (57.2)	2.500 (63.5)	2.010 (51.1)	1.937 (48.6)
36	2 1/4-18 UN	2.938 (74.6)	2.500 (63.5)	2.750 (69.9)	2.260 (57.4)	2.177 (55.3)

Dimensions in Inches (millimeters) are subject to change without notice.

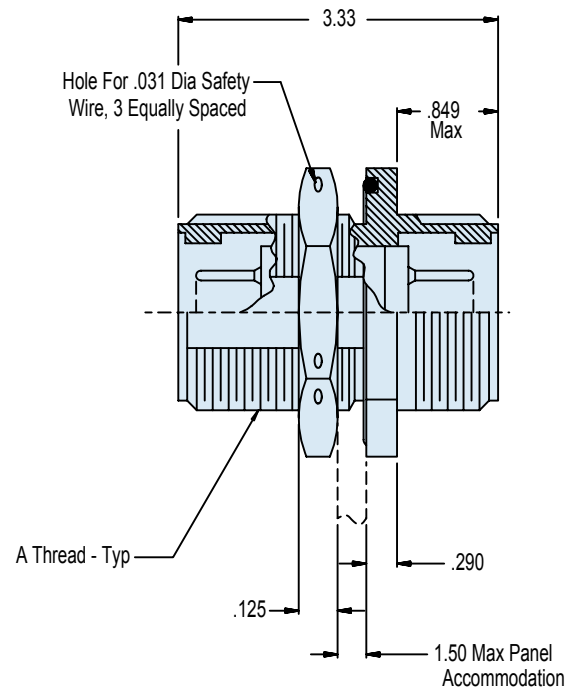
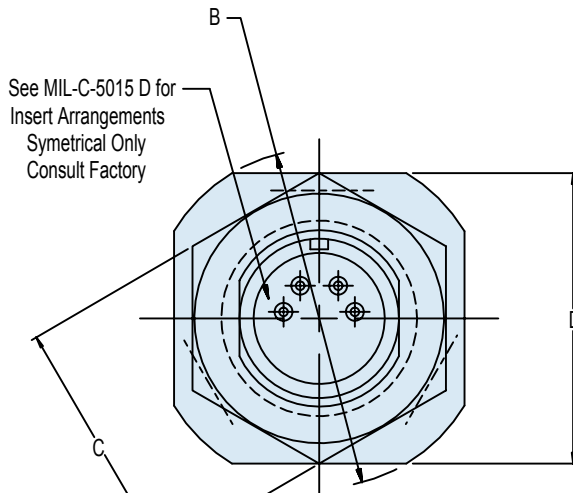
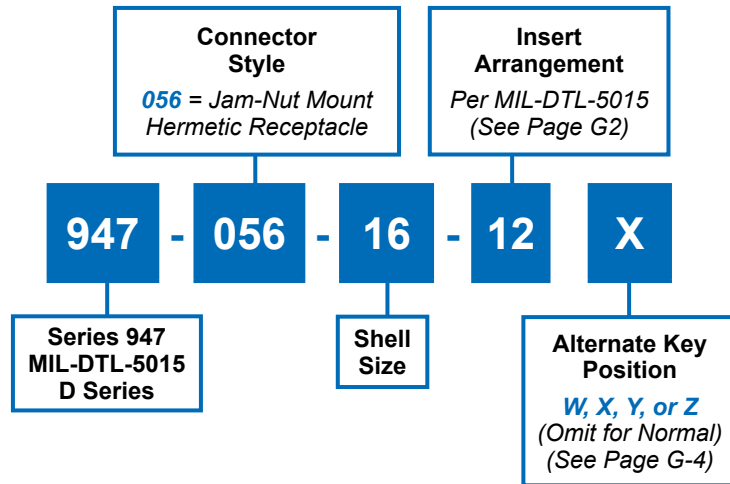

#### APPLICATION NOTES

- Material/Finish:  
Jam-nut, lock-ring, shell\* - Stainless steel/passivated.  
Contacts - Alloy 52/gold plated.  
Insulators - High-grade rigid dielectric, full glass or glass bead.  
O-Rings - Silicone/N.A.
- For pin-to-pin, symmetrical layouts only. Power to a given contact on one end will result in power to contact directly opposite regardless of identification letter.
- Hermeticity - Less than  $1 \times 10^{-7}$  cc/sec at one atmosphere. Not for use in liquid atmosphere.
- Outgas for space application.
- To be identified with manufacturer's name, part number and date code, space permitting.
- Metric Dimensions (mm) are indicated in parentheses.

\* Additional shell materials available, including titanium and Inconel®. Consult factory for ordering information.

Dimensions in Inches (millimeters) are subject to change without notice.

**947-056**  
**MIL-DTL-5015 Type Hermetic**  
**Jam Nut Mount Bulkhead Feed-Thru D Series Connector**  
**with Pin/Pin Contacts**



MIL-DTL-5015  
Type

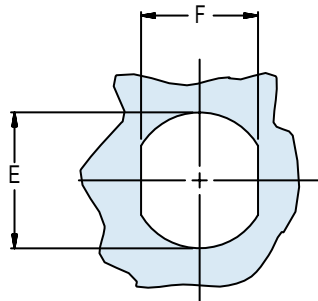

RECOMMENDED PANEL CUT-OUT

HERMETIC LEAK RATE MOD CODES	
Designator	Required Leak Rate
-585A	1 x 10 <sup>-10</sup> cc Helium per second
-585B	1 x 10 <sup>-9</sup> cc Helium per second
-585C	1 x 10 <sup>-8</sup> cc Helium per second



TABLE I: CONNECTOR AND CUT-OUT DIMENSIONS						
Shell Size	A Thread Class 2A	B Dia Max	C Hex	D Flats	E Dia ± .005 (0.1)	F + .005 -.000 (+0.1 - 0.0)
08	1/2-28 UNEF	1.000 (25.4)	.688 (17.5)	.875 (22.2)	.510 (13.0)	.460 (11.7)
10	5/8-24 UNEF	1.125 (28.6)	.812 (20.6)	1.000 (25.4)	.635 (16.1)	.578 (14.7)
12	3/4-20 UNEF	1.250 (31.8)	.938 (23.8)	1.125 (28.6)	.760 (19.3)	.692 (17.6)
14	7/8-20 UNEF	1.375 (34.9)	1.062 (27.0)	1.250 (31.8)	.885 (22.5)	.817 (20.8)
16	1-20 UNEF	1.500 (38.1)	1.250 (31.8)	1.375 (34.9)	1.010 (25.7)	.942 (23.9)
18	1 1/8-18 UNEF	1.750 (44.5)	1.375 (34.9)	1.625 (41.3)	1.135 (28.8)	1.060 (26.9)
20	1 1/4-18 UNEF	1.875 (47.6)	1.500 (38.1)	1.750 (44.5)	1.260 (32.0)	1.185 (30.1)
22	1 3/8-18 UNEF	2.000 (50.8)	1.625 (41.3)	1.875 (47.6)	1.385 (35.2)	1.310 (33.3)
24	1 1/2-18 UNEF	2.188 (55.6)	1.750 (44.5)	2.000 (50.8)	1.510 (38.4)	1.435 (36.4)
28	1 3/4-18 UNEF	2.438 (61.9)	2.000 (50.8)	2.250 (57.2)	1.760 (44.7)	1.687 (42.8)
32	2-18 UNEF	2.688 (68.3)	2.250 (57.2)	2.500 (63.5)	2.010 (51.1)	1.937 (48.6)
36	2 1/4-16 UN	2.938 (74.6)	2.500 (63.5)	2.750 (69.9)	2.260 (57.4)	2.177 (55.3)

Dimensions in Inches (millimeters) are subject to change without notice.





# 947-259 MIL-DTL-5015 Type Hermetic Jam Nut Mount Bulkhead Feed-Thru

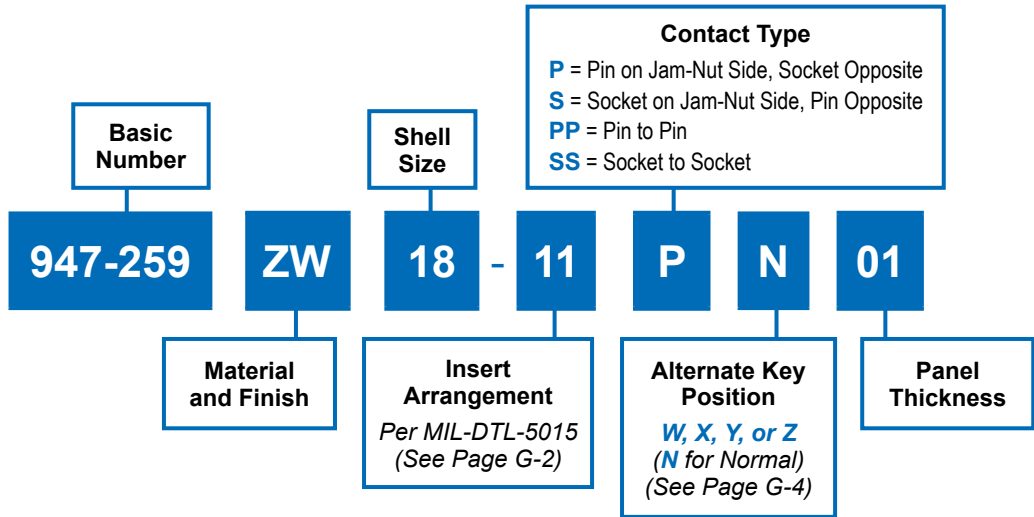

HERMETIC LEAK RATE MOD CODES	
Designator	Required Leak Rate
-585A	1 x 10 <sup>-10</sup> cc Helium per second
-585B	1 x 10 <sup>-9</sup> cc Helium per second
-585C	1 x 10 <sup>-8</sup> cc Helium per second

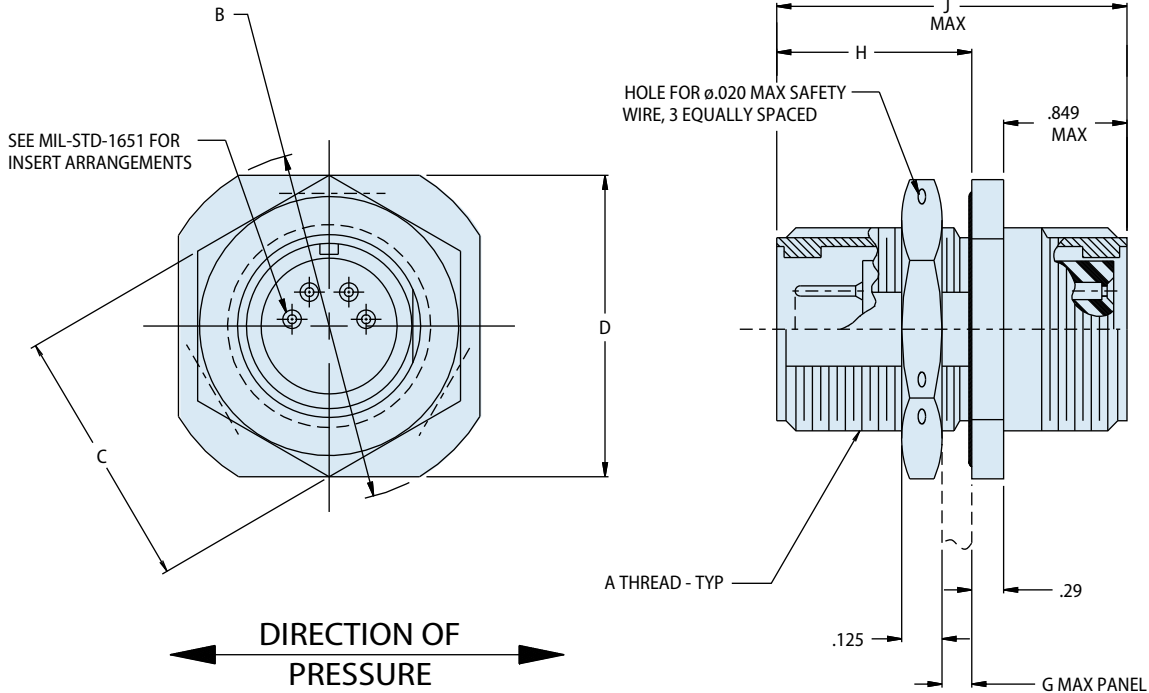

Dimensions in Inches (millimeters) are subject to change without notice.

947-259  
**MIL-DTL-5015 Type Hermetic  
 Jam Nut Mount Bulkhead Feed-Thru**



MIL-DTL-5015  
 Type

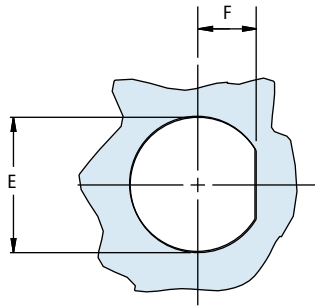

RECOMMENDED PANEL CUT-OUT

TABLE II			
Dash No.	G Max	H	J
01	.250	1.224	2.36
02	.500	1.474	2.62

TABLE I: CONNECTOR AND CUT-OUT DIMENSIONS						
Shell Size	A Thread Class 2A	B Dia Max	C Hex	D Flats	E Dia ± .005 (0.1)	F Dim. Min.
8S	1/2-28 UNEF	1.000 (25.4)	.688 (17.5)	.875 (22.2)	.510 (13.0)	.219 (5.6)
10SL	5/8-24 UNEF	1.125 (28.6)	.812 (20.6)	1.000 (25.4)	.635 (16.1)	.281 (7.1)
12	3/4-20 UNEF	1.250 (31.8)	.938 (23.8)	1.125 (28.6)	.760 (19.3)	.344 (8.7)
12S	3/4-20 UNEF	1.250 (31.8)	.938 (23.8)	1.125 (28.6)	.760 (19.3)	.344 (8.7)
14	7/8-20 UNEF	1.375 (34.9)	1.062 (27.0)	1.250 (31.8)	.885 (22.5)	.406 (10.3)
14S	7/8-20 UNEF	1.375 (34.9)	1.062 (27.0)	1.250 (31.8)	.885 (22.5)	.406 (10.3)
16	1-20 UNEF	1.500 (38.1)	1.250 (31.8)	1.375 (34.9)	1.010 (25.7)	.469 (11.9)
16S	1-20 UNEF	1.500 (38.1)	1.250 (31.8)	1.375 (34.9)	1.010 (25.7)	.469 (11.9)
18	1 1/8-18 UNEF	1.650 (44.5)	1.375 (34.9)	1.625 (41.3)	1.135 (28.8)	.531 (13.5)
20	1 1/4-18 UNEF	1.875 (47.6)	1.500 (38.1)	1.750 (44.5)	1.260 (32.0)	.594 (15.1)
22	1 3/8-18 UNEF	2.000 (50.8)	1.625 (41.3)	1.875 (47.6)	1.385 (35.2)	.656 (16.7)
24	1 1/2-18 UNEF	2.188 (55.6)	1.750 (44.5)	2.000 (50.8)	1.510 (38.4)	.719 (18.3)
28	1 3/4-18 UNEF	2.438 (61.9)	2.000 (50.8)	2.250 (57.2)	1.760 (44.7)	.844 (21.4)
32	2-18 UNEF	2.688 (68.3)	2.250 (57.2)	2.500 (63.5)	2.010 (51.1)	.969 (24.6)
36	2 1/4-16 UN	2.938 (74.6)	2.500 (63.5)	2.750 (69.9)	2.260 (57.4)	1.089 (27.7)
40	2 1/2-16 UN	3.188 (81.0)	2.750 (69.9)	3.000 (76.2)	2.510 (63.7)	1.219 (31.0)
44	2 3/4-16 UN	3.438 (87.3)	3.000 (76.2)	3.250 (82.6)	2.760 (70.1)	1.344 (34.1)
48	3-16 UN	3.688 (93.7)	3.250 (82.6)	3.500 (88.9)	3.010 (76.5)	1.469 (37.3)



APPLICATION NOTES

- |   |  |
|---|--|
| <ol style="list-style-type: none"> <li>To be identified with manufacturer's name, part number and date code, space permitting.</li> <li>For pin/pin and socket/socket symmetrical layouts only, consult factory for available insert arrangements.</li> <li>Power to a given contact on one end will result in power to contact directly opposite regardless of identification letter.</li> <li>Hermeticity - Less than <math>1 \times 10^{-7}</math> cc/sec at one atmosphere.</li> <li>Electrical safety limits must be established by the user. Peak voltage, switching surge, transient voltage, etc. should be used</li> </ol> | <ol style="list-style-type: none"> <li>to determine the safety application.</li> <li>Material/Finish*:<br/>           Jam-nut, lock-ring, shell - stainless steel/O.D. cadmium over nickel<br/>           Contacts - copper alloy/gold plated and alloy 52/gold plate<br/>           Insulators - High-grade rigid dielectric/N.A. and full glass<br/>           Interfacial seals and O-rings - silicone</li> <li>Metric Dimensions (mm) are indicated in parentheses.</li> </ol> |
|---|--|

\* Additional shell materials available, including titanium and Inconel®. Consult factory for ordering information.

Dimensions in Inches (millimeters) are subject to change without notice.



# 947-371 MIL-DTL-5015 Type Hermetic Receptacle Jam Nut Mount Bulkhead Feed-Through

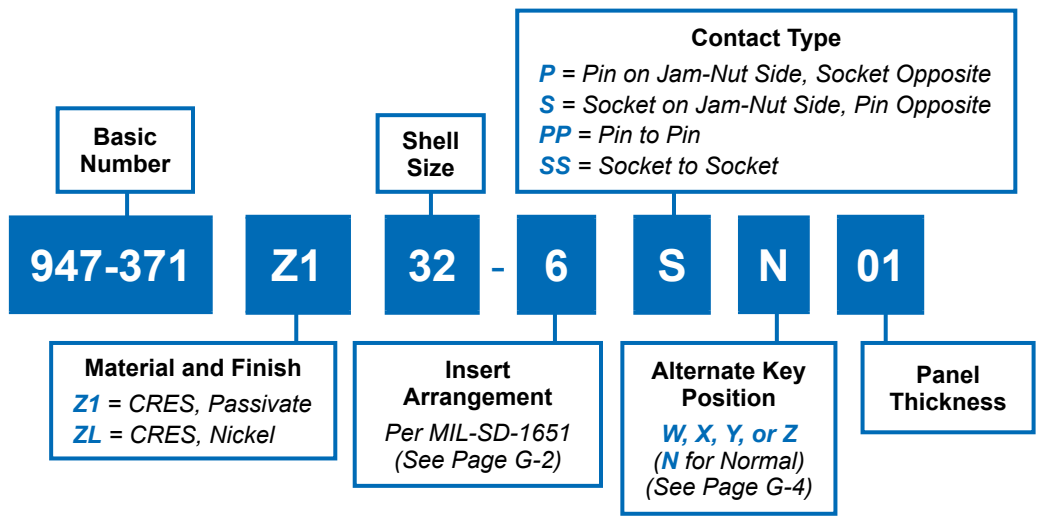

HERMETIC LEAK RATE MOD CODES	
Designator	Required Leak Rate
-585A	1 x 10 <sup>-10</sup> cc Helium per second
-585B	1 x 10 <sup>-9</sup> cc Helium per second
-585C	1 x 10 <sup>-8</sup> cc Helium per second

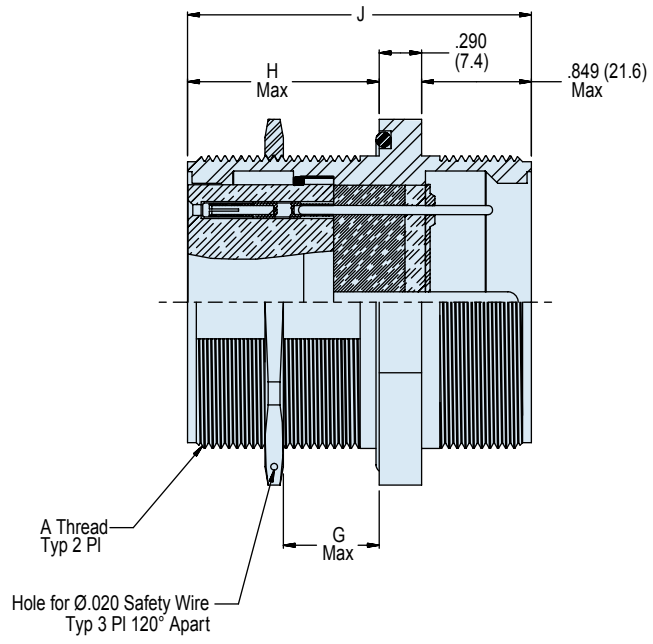
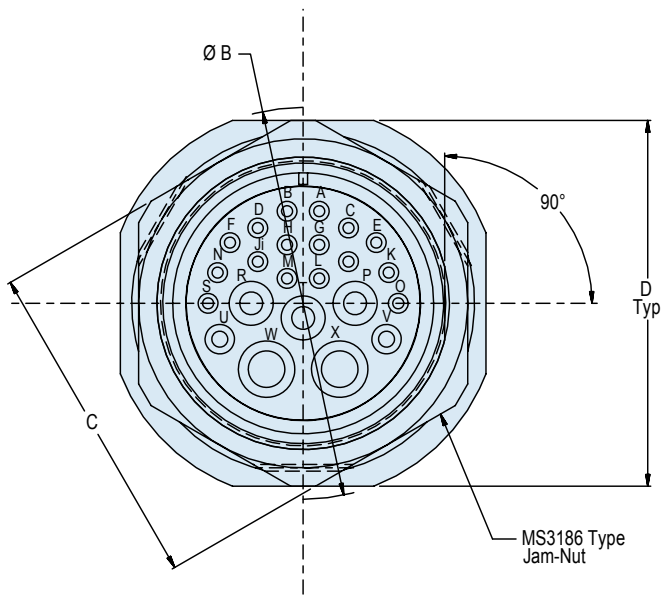

Dimensions in Inches (millimeters) are subject to change without notice.

947-371

MIL-DTL-5015 Type Hermetic Receptacle  
Jam Nut Mount Bulkhead Feed-Through



MIL-DTL-5015  
Type

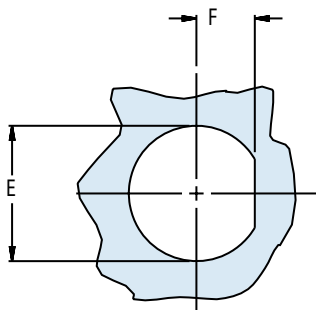

Recommended Panel Cut Out

TABLE II			
Dash No.	G	H	J
01	.125 (3.2)	1.100 (27.9)	2.230 (56.6)
02	.250 (6.4)	1.224 (31.1)	2.360 (59.9)
03	.500 (12.7)	1.474 (37.4)	2.620 (66.5)

TABLE I: CONNECTOR AND CUT-OUT DIMENSIONS						
Shell Size	A Thread Class 2A	B Dia Max	C Hex	D Flats	E Dia ± .005 (0.1)	F Dim. Min.
8S	1/2-28 UNEF	1.000 (25.4)	.688 (17.5)	.875 (22.2)	.510 (13.0)	.219 (5.6)
10SL	5/8-24 UNEF	1.125 (28.6)	.812 (20.6)	1.000 (25.4)	.635 (16.1)	.281 (7.1)
12	3/4-20 UNEF	1.250 (31.8)	.938 (23.8)	1.125 (28.6)	.760 (19.3)	.344 (8.7)
12S	3/4-20 UNEF	1.250 (31.8)	.938 (23.8)	1.125 (28.6)	.760 (19.3)	.344 (8.7)
14	7/8-20 UNEF	1.375 (34.9)	1.062 (27.0)	1.250 (31.8)	.885 (22.5)	.406 (10.3)
14S	7/8-20 UNEF	1.375 (34.9)	1.062 (27.0)	1.250 (31.8)	.885 (22.5)	.406 (10.3)
16	1-20 UNEF	1.500 (38.1)	1.250 (31.8)	1.375 (34.9)	1.010 (25.7)	.469 (11.9)
16S	1-20 UNEF	1.500 (38.1)	1.250 (31.8)	1.375 (34.9)	1.010 (25.7)	.469 (11.9)
18	1 1/8-18 UNEF	1.650 (44.5)	1.375 (34.9)	1.625 (41.3)	1.135 (28.8)	.531 (13.5)
20	1 1/4-18 UNEF	1.875 (47.6)	1.500 (38.1)	1.750 (44.5)	1.260 (32.0)	.594 (15.1)
22	1 3/8-18 UNEF	2.000 (50.8)	1.625 (41.3)	1.875 (47.6)	1.385 (35.2)	.656 (16.7)
24	1 1/2-18 UNEF	2.188 (55.6)	1.750 (44.5)	2.000 (50.8)	1.510 (38.4)	.719 (18.3)
28	1 3/4-18 UNEF	2.438 (61.9)	2.000 (50.8)	2.250 (57.2)	1.760 (44.7)	.844 (21.4)
32	2-18 UNEF	2.688 (68.3)	2.250 (57.2)	2.500 (63.5)	2.010 (51.1)	.969 (24.6)
36	2 1/4-16 UN	2.938 (74.6)	2.500 (63.5)	2.750 (69.9)	2.260 (57.4)	1.089 (27.7)
40	2 1/2-16 UN	3.188 (81.0)	2.750 (69.9)	3.000 (76.2)	2.510 (63.7)	1.219 (31.0)
44	2 3/4-16 UN	3.438 (87.3)	3.000 (76.2)	3.250 (82.6)	2.760 (70.1)	1.344 (34.1)
48	3-16 UN	3.688 (93.7)	3.250 (82.6)	3.500 (88.9)	3.010 (76.5)	1.469 (37.3)

APPLICATION NOTES	
1. To be identified with manufacturer's name, part number and date code, space permitting.	6. Electrical safety limits must be established by the user. Peak voltage, switching surge, transient voltage, etc. should be used to determine the safety application.
2. For pin/pin and socket/socket symmetrical layouts only, consult factory for available insert arrangements.	7. Material/Finish: Jam-nut, lock-ring, shell* - stainless steel/O.D. cadmium over nickel Contacts - copper alloy/gold plated and alloy 52/gold plate Insulators - High-grade rigid dielectric/N.A. and full glass Interfacial seals and O-rings - silicone
3. Power to a given contact on one end will result in power to contact directly opposite regardless of identification letter.	
4. Hermeticity - Less than $1 \times 10^{-7}$ cc/sec at one atmosphere.	
5. Metric Dimensions (mm) are indicated in parentheses.	

\* Additional shell materials available, including titanium and Inconel®. Consult factory for ordering information.

Dimensions in Inches (millimeters) are subject to change without notice.

SERIES 22

# GEO-MARINE®

*Series III Type Hermetic Connectors*



Glenair's Series 22 Geo-Marine® connectors offer high-density insert arrangements for a variety of oceanographic, geophysical and other severe environmental applications. The Mated stainless steel plug and receptacle have a hydrostatic pressure sealing capacity of up to 5000 psi (345 bar), and feature a hermetic glass seal for extremely harsh environments. Because Glenair makes all its hermetic connectors in-house, including the machining of shells, molding of interfacial seals and firing of hermetic components, we can offer you outstanding availability on stock products and fast turnaround on special orders.



**G**lenair®

Glenair, Inc.  
1211 Air Way  
Glendale, CA  
91201-2497  
818-247-6000  
sales@glenair.com  
www.glenair.com

**Series 22 Geo-Marine®  
High Density Severe Environment  
Hermetic Connectors**



**Corrosion Resistant Glass Sealed Hermetic Connectors Designed for Use  
in Harsh Geophysical, Marine and Oil-Patch Applications**

**Series 22 Geo-Marine® hermetic connectors** feature single-start stub-Acme threads for quick coupling of plug and receptacle, reducing thread fouling and binding as a result of dirt, grit and other foreign debris. Receptacles can be ordered in standard and scoop-proof shell styles for

maximum design flexibility. Gold plated nickel-iron alloy 52 solder cup contacts, available in sizes 8, 12, 16, 20 and 22, depending on the layout chosen, offer a wide selection of insert arrangement options.

Quick Selection Guide		
Part Number	Description	Page
	Series 22 Geo-Marine® Product Information	H-2
	Glenair Hermetic Connector Products Space Grade Mod Code	H-3
	Geo-Marine® Insert Arrangements	H-4
	Geo-Marine® Alternate Keyway Positions, Materials and Finishes	H-5
<b>220-00 and 220-10</b>	Front Mounted Jam-Nut Bulkhead Connector Receptacle	H-6
<b>220-01 and 220-11</b>	In-Line Connector Receptacle Assembly	H-8
<b>220-02 and 220-12</b>	Square Flange Mount Connector Receptacle Assembly	H-10
<b>220-03 and 220-13</b>	Solder Mount Bulkhead Connector Receptacle Assembly	H-12
<b>220-04 and 220-14</b>	Rear Mounted Jam Nut Wall Mount Connector Receptacle Assembly	H-14
<b>220-07 and 220-17</b>	Rear Mounted Jam Nut Box Mount Receptacle Assembly	H-16
<b>227-092</b>	Special Scoop-Proof Jam Nut Receptacle, Sizes -10, -12 and -14	H-18
<b>227-039 and 227-040</b>	Jam Nut Mount Bulkhead Feed-Through Connector	H-20



Performance Characteristics			
<b>Hydrostatic Pressure Rating</b>		5000 psi (fully mated)	
<b>Operating Temperature Range</b>		-65°C to +175°C	
<b>Durability</b>		500 Cycles of mate/demate	
Class H Hermetic Receptacles			
<b>Open-Face Pressure Rating</b>		1000 to 5000 psi (Depending on Insert Arrangement)	
<b>Hermeticity</b>		Less than 1 X 10 <sup>-6</sup> sccHe/second @ 1 Atmosphere	
<b>Current Rating</b>		<b>Hermetic</b>	
Contact Size 22		3 amps	
Contact Size 20		5 amps	
Contact Size 16		10 amps	
Contact Size 12		17 amps	
Service Rating	Suggested Operational Voltage (Sea Level)		Test Voltage (Sea Level)
	AC(RMS)	DC	
<b>M</b>	400	550	1300 VMRS
<b>N</b>	300	450	1000 VMRS
<b>I</b>	600	850	1800 VMRS
<b>II</b>	900	1250	2300 VMRS
<b>Insulation Resistance</b>		1000 Megohms minimum at 500 VDC	





## Product Features

- Marine Grade Alloy 316 Stainless Steel machined Shells
- Lockmith Keying Polarization
- Full Line of Accessories:  
Backshells, Protective Covers and Molding Adapters

## Background

Glenair's Geo-Marine® Series 22 product offering is a **third generation** product development. Having started in the harsh environment and Geo-Marine applications since the early 1970's with its "G" and "GL" series, Glenair continued to develop products meeting the increasing and stringent requirements associated with these markets. In doing so, the products became a favorite with the military, especially the US Navy and manufacturers of oil patch equipment.

## Applications

Designed for use in oceanographic, geophysical and other severe commercial/industrial environments, Glenair's line of Geo-Marine® Series 22 Connectors and Cables are designed to withstand hydrostatic pressures up to 5,000 PSI and exposure to extreme temperatures and corrosives.

Our Geo-Marine® products are used in numerous applications, such as US Navy towed array sonar systems, military land vehicles, submersibles and ROV's, offshore oil drilling equipment, seabed exploration, hazardous areas, pipeline inspection systems, well monitoring equipment, and digital seismic streamers.

## Benefits

Utilizing Marine Grade Alloy 316 stainless steel, and insulators made from fused glass for the "H" hermetic class, Glenair offers rugged corrosion resistant Geo-Marine® connectors. The products are available as separate interconnects or may be incorporated into custom cable assemblies. Additionally, for varying applications where solvents, oils, hydraulic fluids, etc., are not compatible with the rubber materials offered as the standard, Glenair can offer alternate rubber options to meet the most severe requirements.

## Receptacles

Receptacles in "H" hermetic class are available in a wide choice of shell styles and insert arrangements. These connectors are designed to mate with the proper corresponding plug, offering an ideally pressure sealed interconnect. This is achieved by the more positive "O" ring piston seal located inside the receptacle barrel-interfacing on the OD of the plug barrel with the added sealing of the plug's seals as previously noted.

The full-spectrum product line also includes **Bulkhead Feedthrough Connectors, Connector Savers** and a complete choice of **Connector Accessories** to satisfy various cable or wire bundle terminations requirements.

Metric dimensions (mm) are indicated in parentheses





## What is outgassing?

Plastic and rubber materials give off gaseous molecules. For example, the smell inside a new car is caused by polymer outgassing. Heat and vacuum increase the rate of diffusion. In a spacecraft the gases coming off polymers can contaminate optical surfaces and instruments. The result is degraded performance.

## How is outgassing measured?

The space industry has adopted a standardized test procedure, **ASTM E 595**, to evaluate out-gassing properties of polymers. Small samples of material are heated to 125° C. at a vacuum of  $5 \times 10^{-5}$  torr for 24 hours. Then the sample is weighed to calculate the **Total Mass Loss** (TML). The TML cannot exceed 1.00% of the total initial mass. During the test, outgassed matter condenses on a cooled collector plate. The quantity of outgassed matter is calculated to determine the **Collected Volatile Condensable Material** (CVCN). The CVCN cannot exceed 0.10% of the original specimen mass.

## What is NASA screening?

NASA specification EEE-INST-002 provides instructions on selecting, screening and qualifying parts for use on NASA GSFC space flight projects.

## What screening level is required?

NASA defines three levels of screening: level 1 for highest reliability, level 2 for high reliability, and level 3 for standard reliability. Level 3 equates to standard lot acceptance inspection. Levels 1 and 2 call for additional testing.

## HOW TO ORDER SPACE GRADE CONNECTORS

### Step 1: Find a Standard Part Number

Electroless nickel plated shells are preferred for space flight. Cadmium plating is prohibited.

### Step 2: Select a NASA Screening Level

The term "Screening Level" refers to the final inspection procedure.

**Level 1** for mission-critical highest reliability

**Level 2** for high reliability

**Level 3** for standard reliability

### Step 3: Choose Outgassing Processing

A detailed explanation of outgassing is on the following pages. The fluorosilicone rubber seals commonly used on aerospace-grade connectors such as MIL-DTL-38999 and Series 79 connectors, along with certain bonding agents and inks, do not meet NASA outgassing requirements unless the connector is specially processed. Glenair outgassing tests have shown oven baking or thermal vacuum outgassing processing are sufficient to reduce outgassing levels to NASA standards. Oven baking is more economical than thermal vacuum outgassing.

### Step 4: Select the Mod 429 Code that Matches the Desired Level of Screening and Outgassing

Use the following table to choose the right modification code. Add the mod code to the connector part number. Example: 790-024PC-13ML-**429C**

## NASA SCREENING LEVELS AND MODIFICATION CODES

NASA Screening Level	Special Screening Only	Special Screening Plus Outgassing Processing	
		8 Hour Oven Bake 400° F.	Thermal Vacuum Outgassing 24 hrs. 125° C.
Level 1 Highest Reliability	Mod 429B	Mod 429J	Mod 429C
Level 2 High Reliability	Mod 429	Mod 429K	Mod 429A
Level 3 Standard Reliability	(Use standard part number)	Mod 186	Mod 186M



# Series 22 Geo-Marine® Connectors Insert Arrangements

## Geo-Marine® Contact Arrangements

Front Face of Pin Inserts Illustrated. Service Ratings Indicated in Parentheses.

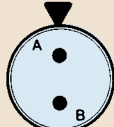

10-2 (I)



10-4 (I)



10-6 (I)



10-13 (M)

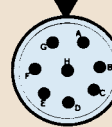

12-8 (I)

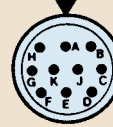

12-10 (I)

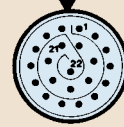

12-22 (M)

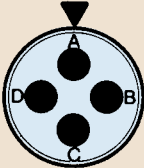

14-4 (I)

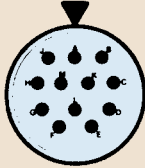

14-12 (II)

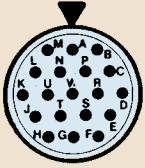

14-19 (I)

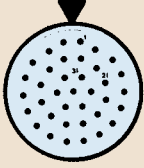

14-37 (M)

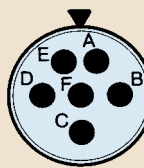

16-6 (I)

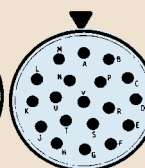

16-19 (II)

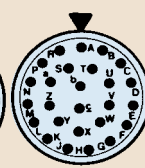

16-26 (I)



16-55 (M)

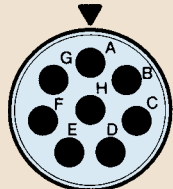

18-8 (I)

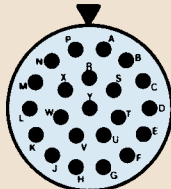

18-22 (II)

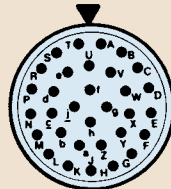

18-32 (I)

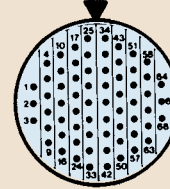

18-66 (M)

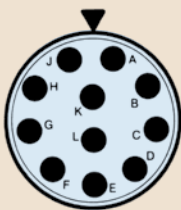

20-11 (I)

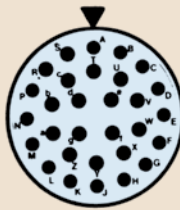

20-30 (II)

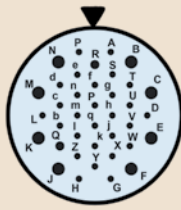

20-38 (I)

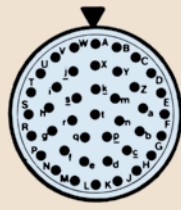

20-41 (I)

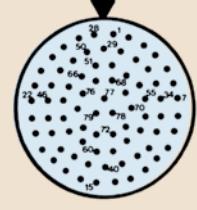

20-79 (M)

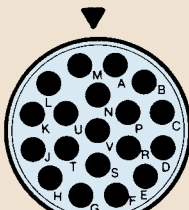

22-19 (I)

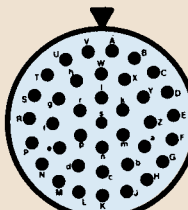

22-38 (II)

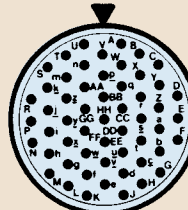

22-55 (I)

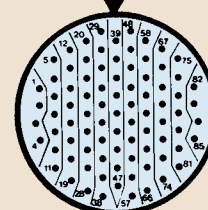

22-85 (M)

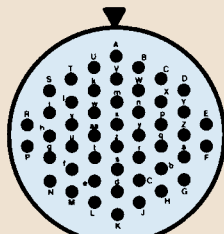

24-48 (I)

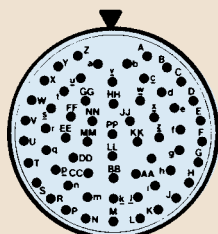

24-61 (I)

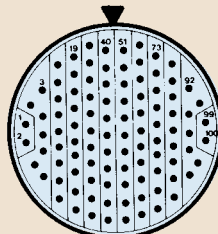

24-100 (M)

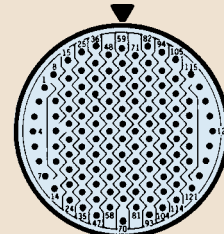

24-128 (M)

Metric dimensions (mm) are indicated in parentheses

# Series 22 Geo-Marine® Connectors Alternate Keyway Positions



Contact Arrangements						
SHELL SIZE	SERIES 22 PATTERN	SERVICE RATING	CONTACT SIZE/QUANTITY			
			22	20	16	12
10	10-2	II			2	
	10-04	I		4		
	10-06	I		6		
	10-13	M	13			
12	12-08	II			8	
	12-10	I		10		
	12-22	M	22			
14	14-04	II				4
	14-12	II			14	
	14-19	I		19		
	14-37	M	37			
16	16-06	II				6
	16-19	II			19	
	16-26	I		26		
	16-55	M	55			
18	18-08	I		8		
	18-22	II			22	
	18-32	I		32		
	18-66	M	66			
20	20-11	II				11
	20-30	II			30	
	20-38	I		30	8	
	20-41	I		41		
	20-79	M	79			
22	22-19	II				19
	22-38	II			38	
	22-55	I		55		
	22-85	M	85			
24	24-48	II			48	
	24-61	I		61		
	24-100	M	100			
	24-128	M	128			

**Alternate Keyway Positions**

SHELL SIZE DESIG.	N°	1°	2°	3°	4°
10	90	76	62	118	104
12	90	70	58	122	110
14	90	69	56	124	111
16	90	72	60	120	108
18	90	72	62	120	108
20	90	72	60	120	108
22	90	75	64	116	105
24	90	75	64	115	105

Depth/Pressure Conversion			
Feet	Meters	P.S.I.	Bar
1	.3	.4	.0296
10	3.1	4.3	.2965
50	15.2	21.7	1.4962
100	30.5	43.3	2.9854
250	76.2	108.3	7.4670
500	152.4	216.5	24.9271
1,000	304.8	433.0	29.8543
1,500	457.2	649.5	44.7814
2,500	762.0	1082.5	74.6357
5,000	1524.0	2165.0	149.2715
10,000	3048.0	4330.0	298.5430
11,547	3519.35	5000.0	344.7379

**Custom Contact Arrangements**

Series 22 inserts may be tooled for alternative contact insert arrangements including variably sized electrical contacts—from size 12 to 22—as well as hybrid arrangements incorporating fiber optic, Co-ax and other contact types. Glenair has produced hundreds of custom arrangements beyond those shown in this catalog. Please contact your local Glenair representative, or the factory, for assistance.

Materials / Finishes		
ITEM	MATERIAL	FINISH
Connector Shells	CRS Alloy 316 SAE-AMS-QQ-S-763	Passivate-ASTM A967
Solder Mount Bulkhead Receptacle	CRS 316 SAE-AMS-QQ-S-763	Nickel SAE-AMS-QQ-N-290, Class 2
Insulators, Class "H"	Fused Vitreous Glass	None
Contacts, Pin Class "H"	Nickel-Iron Alloy 52 - MIL-I-23011, Class 2	Gold/Ni AMS
Contacts, Socket	Beryllium Copper	Gold
Contacts, Socket Hood	CRS QQ-S-763, AISI 305	Passivate-ASTM A967
"O"-Rings	Nitrile (Buna-N) Rubber MIL-G-21569	None
Interfacial & Peripheral Seals	Flourosilicone Rubber MIL-R-25988	None

Additional materials are available, including titanium and Inconel®. Consult factory for ordering information.

Cable/Wire D.C. Resistance	
Copper Conductors at Room Temperature	
AWG	Ohms per 1000 feet
28	66.2 Max
26	41.6 Max
24	26.2 Max
22	16.5 Max
20	10.4 Max
18	6.5 Max
16	4.1 Max
14	2.6 Max
12	1.6 Max

Metric dimensions (mm) are indicated in parentheses



## 220-00 and 220-10 Front Mounted Bulkhead Receptacle Connector

### How To Order

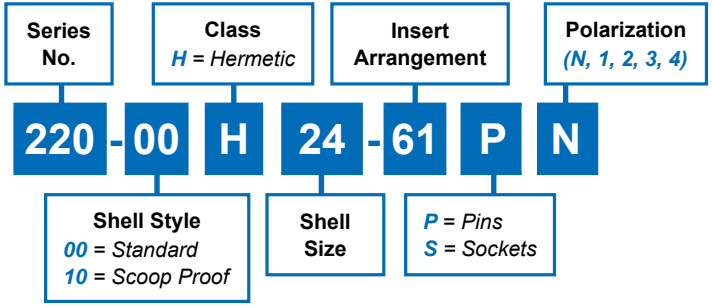

H

220-00: 1.32 (33.5) Max  
220-10: 1.57 (39.9) Max

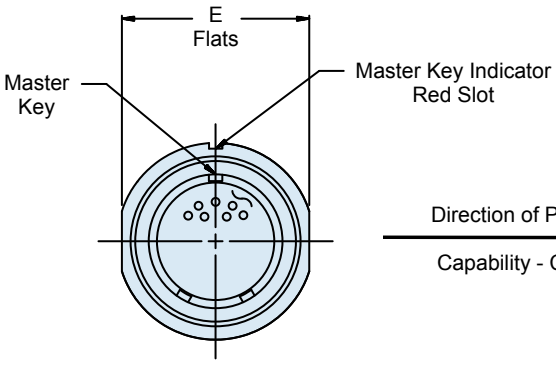

Direction of Pressure  
Capability - Class H

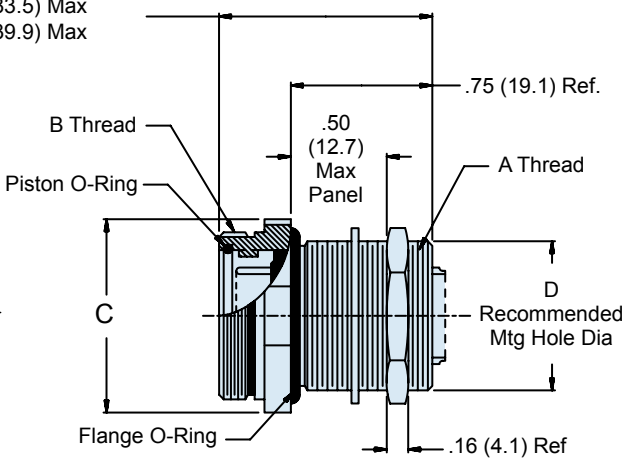

#### APPLICATION NOTES

1. Prior to use, lubricate O-rings with high grade silicone lubricant (Moly-kote M55 or equivalent).
2. Hermeticity rating: less than  $1 \times 10^{-6}$  cc helium per second.
3. Open face pressure rating: 1000 to 5000 psi

Metric dimensions (mm) are indicated in parentheses

# 220-00 and 220-10 Front Mounted Bulkhead Receptacle Connector



Dimensions							
Shell Size	A Thread Class 2A	B Thread Class 2A	Ø C Max		D		E Flats
					±.005	±(0.1)	
10	5/8 - 24 UNEF	.750 - .1P - .1L	1.03	(26.2)	.635	(16.1)	.875 (22.2)
12	3/4 - 20 UNEF	.875 - .1P - .1L	1.16	(29.5)	.760	(19.3)	1.000 (25.4)
14	7/8 - 20 UNEF	1.000 - .1P - .1L	1.28	(32.5)	.885	(22.5)	1.125 (28.6)
16	1 - 20 UNEF	1.125 - .1P - .1L	1.41	(35.8)	1.010	(25.7)	1.250 (31.8)
18	1 1/8 - 16 UN	1.250 - .1P - .1L	1.66	(42.2)	1.135	(28.8)	1.500 (38.1)
20	1 1/4 - 16 UN	1.375 - .1P - .1L	1.78	(45.2)	1.260	(32.0)	1.625 (41.3)
22	1 3/8 - 16 UN	1.500 - .1P - .1L	1.91	(48.5)	1.385	(35.2)	1.750 (44.5)
24	1 1/2 - 16 UN	1.625 - .1P - .1L	2.03	(51.6)	1.510	(38.4)	1.875 (47.6)



Recommended Jam Nut Installation Torque Values		
Shell Size	Torque ± 5%	
	Inch - Lbs.	Newton - Meters
10	95	10.73
12	110	12.43
14	140	15.82
16	170	19.21
18	195	22.03
20	215	24.29
22	235	26.55
24	260	29.38

Replacement O-Ring Part Numbers*		
Shell Size	Piston O-Ring	Flange O-Ring
10	2-014	2-017
12	2-016	2-019
14	2-018	2-021
16	2-020	2-023
18	2-022	2-025
20	2-024	2-027
22	2-026	2-029
24	2-028	2-030

\*Parker O-Ring Part Numbers. Compound N674-70 Or Equivalent

Metric dimensions (mm) are indicated in parentheses



## 220-01 and 220-11 In-Line Connector Receptacle

### How To Order

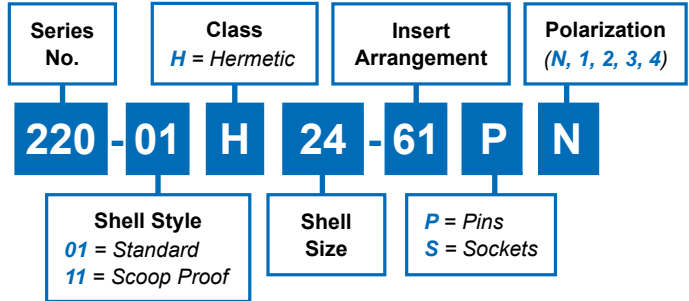

H

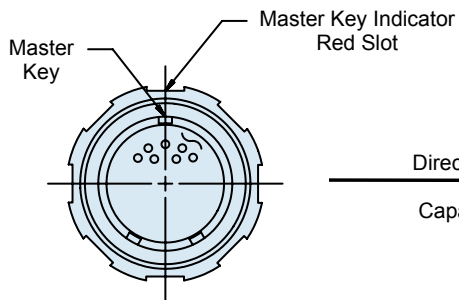

Direction of Pressure  
Capability - Class H

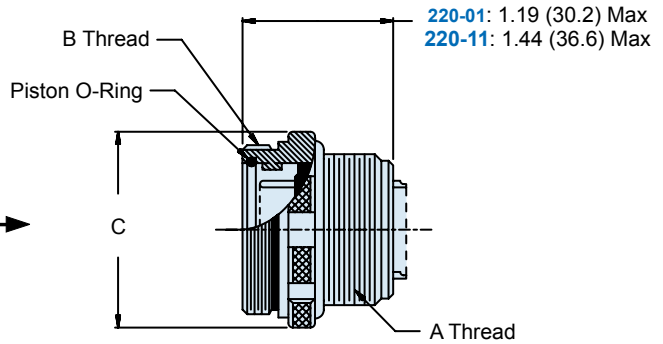

#### APPLICATION NOTES

1. Prior to use, lubricate O-rings with high grade silicone lubricant (Moly-kote M55 or equivalent).
2. Hermeticity rating: less than  $1 \times 10^{-6}$  cc helium per second.
3. Open face pressure rating: 1000 to 5000 psi

Metric dimensions (mm) are indicated in parentheses

## 220-01 and 220-11 In-Line Connector Receptacle



Dimensions			
Shell Size	A Thread Class 2A	B Thread Class 2A	Ø C Max
10	5/8 - 24 UNEF	.750 - .1P - .1L	.906 (23.0)
12	3/4 - 20 UNEF	.875 - .1P - .1L	1.031 (26.2)
14	7/8 - 20 UNEF	1.000 - .1P - .1L	1.156 (29.4)
16	1 - 20 UNEF	1.125 - .1P - .1L	1.281 (32.5)
18	1 1/18 - 16 UN	1.250 - .1P - .1L	1.531 (38.9)
20	1 1/4 - 16 UN	1.375 - .1P - .1L	1.656 (42.1)
22	1 3/8 - 16 UN	1.500 - .1P - .1L	1.781 (45.2)
24	1 1/2 - 16 UN	1.625 - .1P - .1L	1.906 (48.4)

Replacement O-Ring Part Numbers*	
Shell Size	Piston O-Ring
10	2-014
12	2-016
14	2-018
16	2-023
18	2-022
20	2-024
22	2-026
24	2-028
*Parker O-Ring Part Numbers. Compound N674-70 Or Equivalent	

Metric dimensions (mm) are indicated in parentheses





## 220-02 and 220-12 Square Flange Mount Receptacle

### How To Order

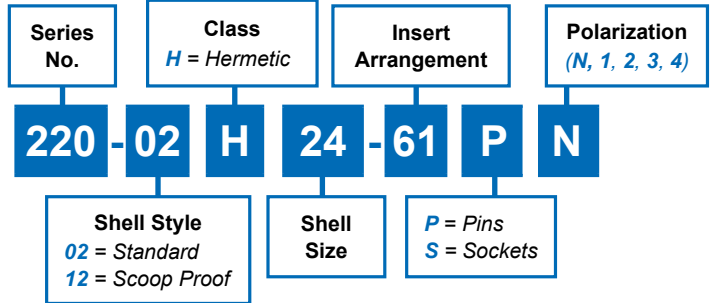

H

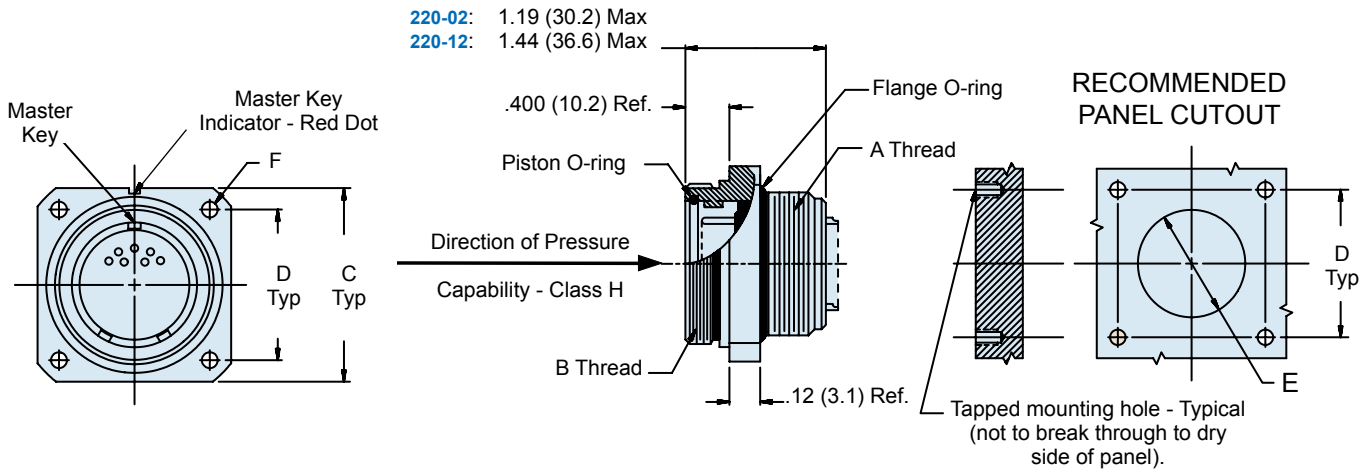

### APPLICATION NOTES

1. Prior to use, lubricate O-rings with high grade silicone lubricant (Moly-kote M55 or equivalent).
2. Hermeticity rating: less than  $1 \times 10^{-6}$  cc helium per second.
3. Open face pressure rating: 1000 to 5000 psi

Metric dimensions (mm) are indicated in parentheses

## 220-02 and 220-12 Square Flange Mount Receptacle



Dimensions					
SHELLSIZE	A THREAD CLASS 2A	B THREAD CLASS 2A	C DIM	D DIM	E DIA + .015 + (0.4) - .000 - (0.0)
10	5/8 - 24 UNEF	.750 - .1P - .1L	1.188 (30.2)	.938 (23.8)	.844 (21.4)
12	3/4 - 20 UNEF	.875 - .1P - .1L	1.312 (33.3)	1.062 (27.0)	.969 (24.6)
14	7/8 - 20 UNEF	1.000 - .1P - .1L	1.438 (36.5)	1.188 (30.2)	1.078 (27.4)
16	1 - 20 UNEF	1.125 - .1P - .1L	1.562 (39.7)	1.250 (31.8)	1.219 (31.0)
18	1 1/8 - 16 UN	1.250 - .1P - .1L	1.750 (44.5)	1.375 (34.9)	1.359 (34.5)
20	1 1/4 - 16 UN	1.375 - .1P - .1L	1.875 (47.6)	1.500 (38.1)	1.515 (38.5)
22	1 3/8 - 16 UN	1.500 - .1P - .1L	2.000 (50.8)	1.625 (41.3)	1.640 (41.7)
24	1 1/2 - 6 UN	1.625 - .1P - .1L	2.125 (54.0)	1.750 (44.5)	1.765 (44.8)

Mounting/Hardware Information		
SHELL SIZE	F DIA	MTG SCREW REF.
10	.125 (3.2)	No. 4
12	.125 (3.2)	No. 4
14	.125 (3.2)	No. 4
16	.125 (3.2)	No. 4
18	.125 (3.2)	No. 4
20	.125 (3.2)	No. 4
22	.125 (3.2)	No. 4
24	.156 (4.0)	No. 6

Replacement O-Ring Part Numbers		
SHELL SIZE	PISTON O-RING	FLANGE O-RING
10	2-014	2-021
12	2-016	2-023
14	2-018	2-025
16	2-020	2-027
18	2-022	2-029
20	2-024	2-030
22	2-026	2-031
24	2-028	2-032

\*Parker o-ring part numbers. Compound N674-70 or equivalent.

Metric dimensions (mm) are indicated in parentheses



## 220-03 and 220-13 Solder Mount Bulkhead Receptacle

### How To Order

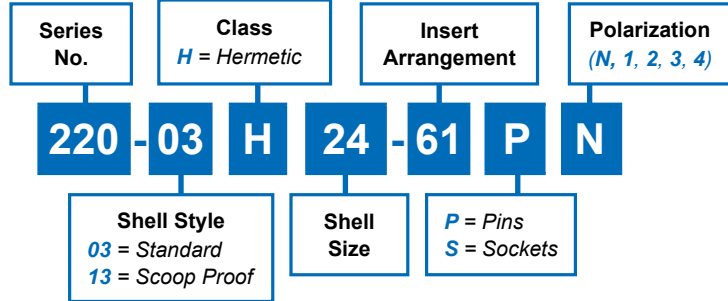

H

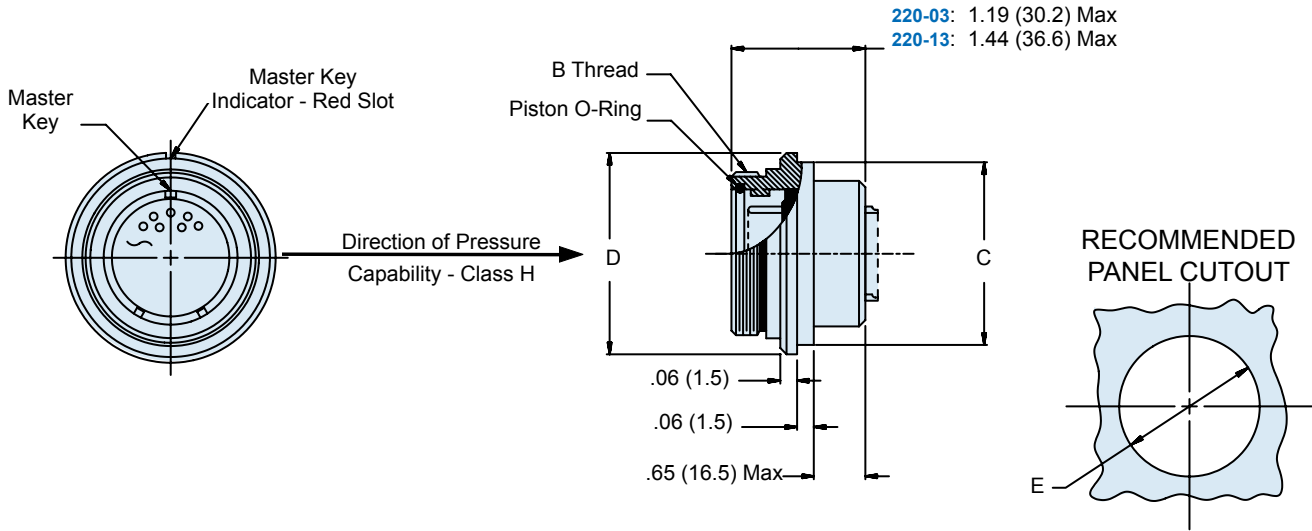

#### APPLICATION NOTES

1. Prior to use, lubricate O-rings with high grade silicone lubricant (Moly-kote M55 or equivalent).
2. Hermeticity rating: less than  $1 \times 10^{-6}$  cc helium per second.

Metric dimensions (mm) are indicated in parentheses

**220-03 and 220-13  
Solder Mount Bulkhead Receptacle**



Dimensions				
SHELL SIZE	B THREAD CLASS 2A	C DIA MAX	D DIA	E DIA +.010+(0.3) -.000 -(0.0)
10	.750 - .1P - .1L	.870 (22.1)	1.00 (25.4)	.875 (22.2)
12	.875 - .1P - .1L	.995 (25.3)	1.13 (28.7)	1.000 (25.4)
14	1.000 - .1P - .1L	1.120 (28.4)	1.25 (31.8)	1.125 (28.6)
16	1.125 - .1P - .1L	1.245 (31.6)	1.38 (35.1)	1.250 (31.8)
18	1.250 - .1P - .1L	1.370 (34.8)	1.50 (38.1)	1.375 (34.9)
20	1.375 - .1P - .1L	1.495 (38.0)	1.63 (41.4)	1.500 (38.1)
22	1.500 - .1P - .1L	1.620 (41.1)	1.75 (44.5)	1.625 (41.3)
24	1.625 - .1P - .1L	1.745 (44.3)	1.88 (47.8)	1.750 (44.5)

Replacement O-Ring Part Numbers *	
SHELL SIZE	PISTON O-RING
10	2-014
12	2-016
14	2-018
16	2-020
18	2-022
20	2-024
22	2-026
24	2-028
* Parker O-ring part numbers. Compound N674-70 or equivalent.	

Metric dimensions (mm) are indicated in parentheses



## 220-04 and 220-14 Rear Wall Mount Jam Nut Receptacle

### How To Order

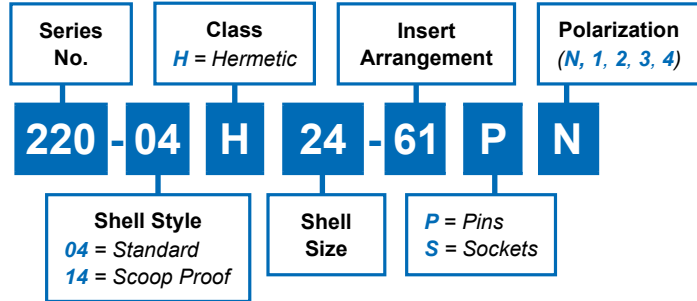

H

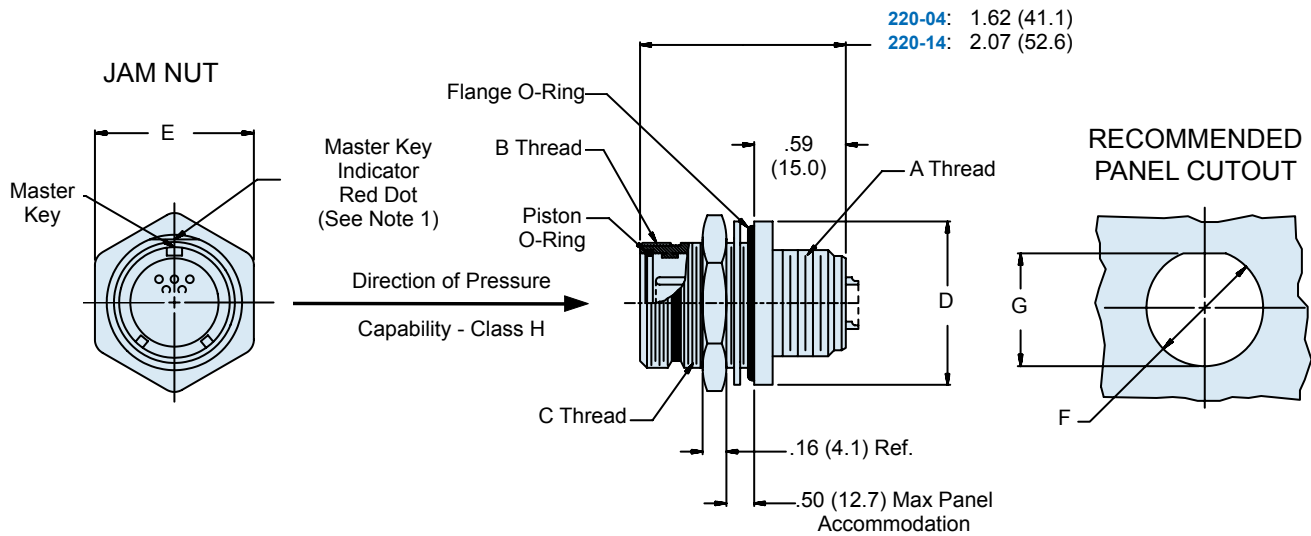

### APPLICATION NOTES

1. Flat and master key indicator rotates with master key per position noted on Page A-4.
2. Hermeticity rating: less than  $1 \times 10^{-6}$  cc helium per second.
3. Open face pressure rating: 1000 to 5000 psi

Metric dimensions (mm) are indicated in parentheses

# 220-04 and 220-14 Rear Wall Mount Jam Nut Receptacle



### Dimensions

SHELL SIZE	A THREAD CLASS 2A	B THREAD CLASS 2A	C THREAD CLASS 2A	D DIA	E FLATS	F DIA ±.005±(0.1)	G ±.005±(0.1)
10	5/8 - 24 UNEF	.750 - .1P - .1L	7/8 - 20 UNEF	1.25 (31.8)	1.125 (28.6)	.885 (22.5)	.835 (21.2)
12	3/4 - 20 UNEF	.875 - .1P - .1L	1 - 20 UNEF	1.38 (35.1)	1.250 (31.8)	1.010 (25.7)	.960 (24.4)
14	7/8 - 20 UNEF	1.000 - .1P - .1L	1 1/8 - 16 UN	1.50 (38.1)	1.500 (38.1)	1.135 (28.8)	1.085 (27.6)
16	1 - 20 UNEF	1.125 - .1P - .1L	1 1/4 - 16 UN	1.63 (41.4)	1.625 (41.3)	1.260 (32.0)	1.210 (30.7)
18	1 1/8 - 16 UN	1.250 - .1P - .1L	1 3/8 - 16 UN	1.75 (44.5)	1.750 (44.5)	1.385 (35.2)	1.335 (33.9)
20	1 1/4 - 16 UN	1.375 - .1P - .1L	1 1/2 - 16 UN	1.88 (47.8)	1.875 (47.6)	1.510 (38.4)	1.460 (37.1)
22	1 3/8 - 16 UN	1.500 - .1P - .1L	1 5/8 - 16 UN	2.00 (50.8)	2.000 (50.8)	1.635 (41.5)	1.585 (40.3)
24	1 1/2 - 16 UN	1.625 - .1P - .1L	1 3/4 - 16 UN	2.12 (53.8)	2.125 (54.0)	1.760 (44.7)	1.710 (43.4)

### Recommended Jam Nut Installation Torque Values

SHELL SIZE	TORQUE ± 5%	
	INCH-POUNDS	NEWTON-METERS
10	95	10.73
12	110	12.43
14	140	15.82
16	170	19.21
18	195	22.03
20	215	24.29
22	235	26.55
24	260	29.38

### Replacement O-Ring Part Numbers \*

SHELL SIZE	PISTON O-RING	FLANGE O-RING
10	2-014	2-021
12	2-016	2-023
14	2-018	2-025
16	2-020	2-027
18	2-022	2-029
20	2-024	2-030
22	2-026	2-031
24	2-028	2-032

\* Parker O-ring part numbers. Compound N674-70 or equivalent.

Metric dimensions (mm) are indicated in parentheses



## 220-07 and 220-17 Rear Mounted Jam Nut Box Mount Receptacle

### How To Order

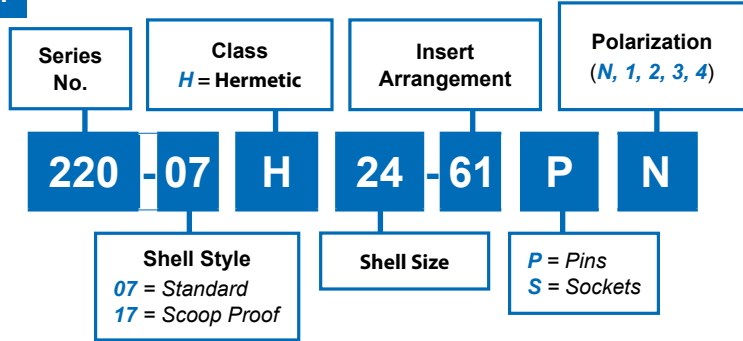

H

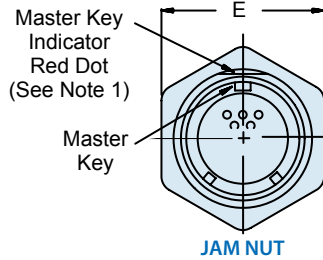
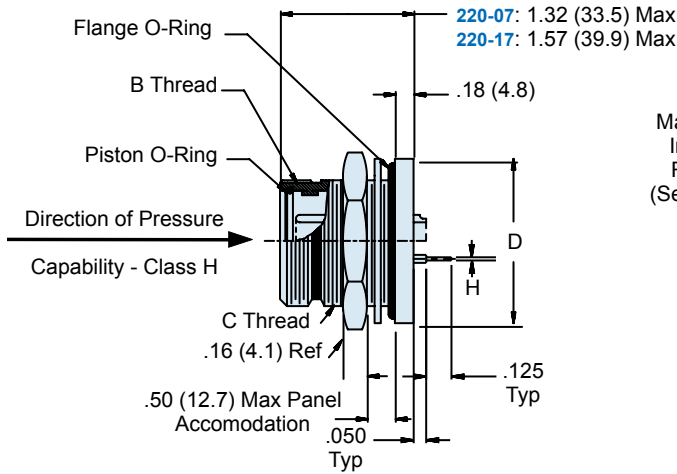

### RECOMMENDED PANEL CUTOUT

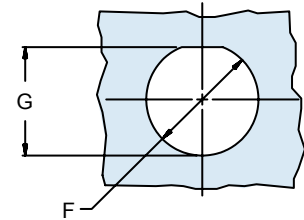

Prior to use, lubricate O-Rings with high grade silicone lubricant (Moly-Kote M55 or equivalent).

### APPLICATION NOTES

1. Flat and Master Key Indicator rotates with Master Key, per Key position noted on Page A-4
2. Hermeticity rating: less than 1x10-6 cc helium per second.
3. Open face pressure rating: 1000 to 5000 psi.

Metric dimensions (mm) are indicated in parentheses



# 220-07 and 220-17 Rear Mounted Jam Nut Box Mount Receptacle



Dimensions								
SHELL SIZE	B THREAD CLASS 2A	C THREAD CLASS 2A	D DIA	E FLATS	F DIA ±.005±(0.1)	G ±.005±(0.1)	CONTACT SIZE	H DIA
10	.750 - .1P - .1L	7/8 - 20 UNEF	1.25 (31.8)	1.125 (28.6)	.885 (22.5)	.835 (21.2)	12	.095/.093 (2.413/2.362)
12	.875 - .1P - .1L	1 - 20 UNEF	1.38 (35.1)	1.250 (31.8)	1.010 (25.7)	.960 (24.4)		
14	1.000 - .1P - .1L	1 1/8 - 16 UN	1.50 (38.1)	1.500 (38.1)	1.135 (28.8)	1.085 (27.6)	16	.0635/.061 (1.613/1.549)
16	1.125 - .1P - .1L	1 1/4 - 16 UN	1.63 (41.4)	1.625 (41.3)	1.260 (32.0)	1.210 (30.7)		
18	1.250 - .1P - .1L	1 3/8 - 16 UN	1.75 (44.5)	1.750 (44.5)	1.385 (35.2)	1.335 (33.9)	20	.028/.024 (0.711/0.610)
20	1.375 - .1P - .1L	1 1/2 - 16 UN	1.88 (47.8)	1.875 (47.6)	1.510 (38.4)	1.460 (37.1)		
22	1.500 - .1P - .1L	1 5/8 - 16 UN	2.00 (50.8)	2.000 (50.8)	1.635 (41.5)	1.585 (40.3)	22	.021/.018 (0.533/0.457)
24	1.625 - .1P - .1L	1 3/4 - 16 UN	2.12 (53.8)	2.125 (54.0)	1.760 (44.7)	1.710 (43.4)		

Metric dimensions (mm) are indicated in parentheses.



Recommended Jam Nut Installation Torque Values		
SHELLSIZE	TORQUE ± 5%	
	INCH-POUNDS	NEWTON-METERS
10	95	10.73
12	110	12.43
14	140	15.82
16	170	19.21
18	195	22.03
20	215	24.29
22	235	26.55
24	260	29.38

Replacement O-Ring Part Numbers *		
SHELL SIZE	PISTON O-RING	FLANGE O-RING
10	2-014	2-021
12	2-016	2-023
14	2-018	2-025
16	2-020	2-027
18	2-022	2-029
20	2-024	2-030
22	2-026	2-031
24	2-028	2-032

\* Parker O-ring part numbers.  
Compound N674-70 or equivalent.

Metric dimensions (mm) are indicated in parentheses



**227-092**  
**Special Scoop-Proof Jam Nut Receptacle**  
 Shell Sizes -10, -12 and -14

**How To Order**

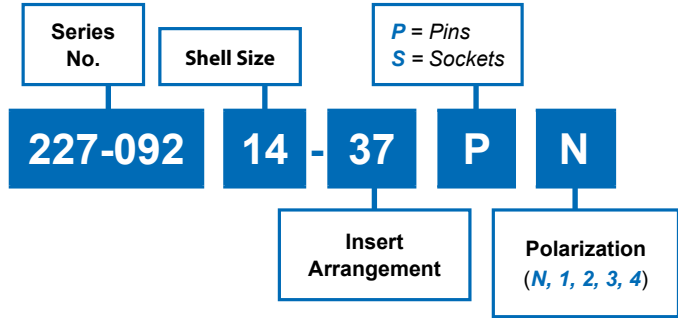

**H**

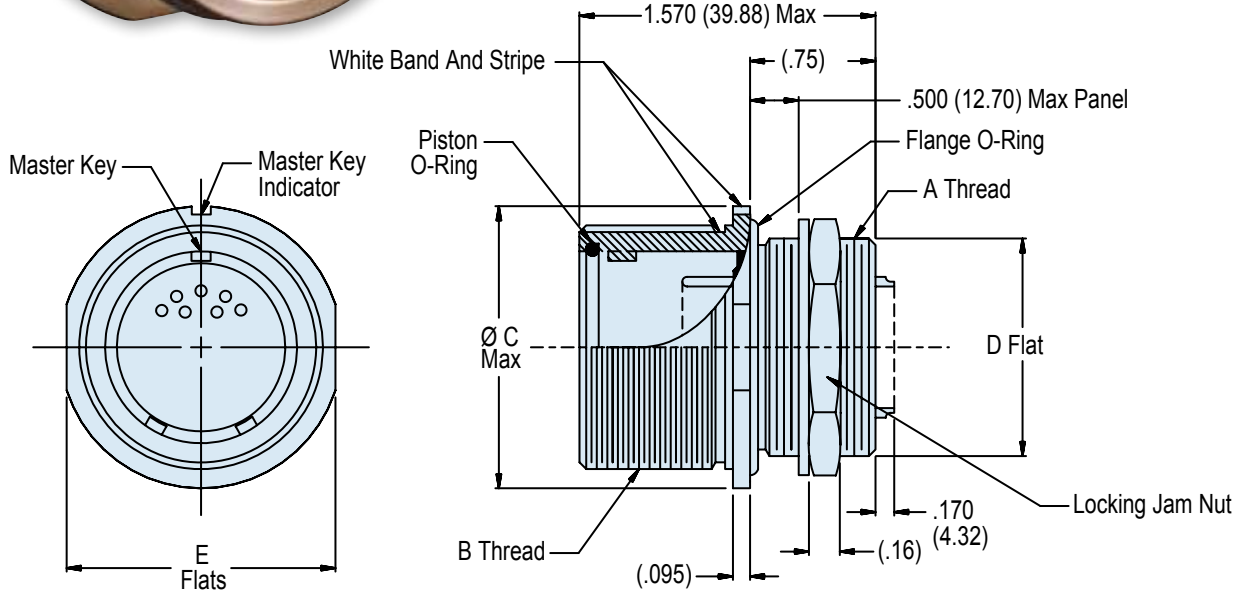

Prior to use, lubricate O-Rings with high grade silicone lubricant (Moly-Kote M55 or equivalent).

APPLICATION NOTES
1. Current rating: Size 22 contact - 500 VDC, 3 Amps.
2. Hydrostatic pressure rating: 5000 PSI, fully mated.
3. Insulation resistance: 1000 MegOhms min at 500 VDC.

**227-092**  
**Special Scoop-Proof Jam Nut Receptacle**  
 Shell Sizes -10, -12 and -14



Dimensions							
SHELL SIZE	A THREAD CLASS 2A	B THREAD CLASS 2A	C DIA	D FLAT	E FLATS	F +.005 -(0.1)	G +.005 -(0.1)
-10	5/8-24 UNEF	.750 -.1P -.1L	1.030 (26.16)	.594 (15.09)	.875 (22.23)	.606 (15.39)	.645 (16.38)
-12	3/4-20 UNEF	.875 -.1P -.1L	1.160 (29.46)	.709 (18.01)	1.000 (25.40)	.721 (18.31)	.770 (19.56)
-14	7/8-20 UNEF	1.000 -.1P -.1L	1.280 (32.51)	.834 (21.18)	1.125 (28.58)	.846 (21.49)	.895 (22.73)

Metric dimensions (mm) are indicated in parentheses.

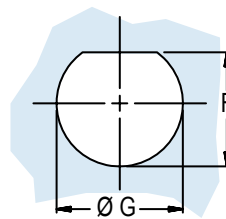

**Recommended  
Panel Cut-out**



Metric dimensions (mm) are indicated in parentheses



227-039 and 227-040  
Jam Nut Mount Bulkhead Feed-Through Connector  
Environmental or Hermetic

**Bulkhead feed-through for high pressure applications**

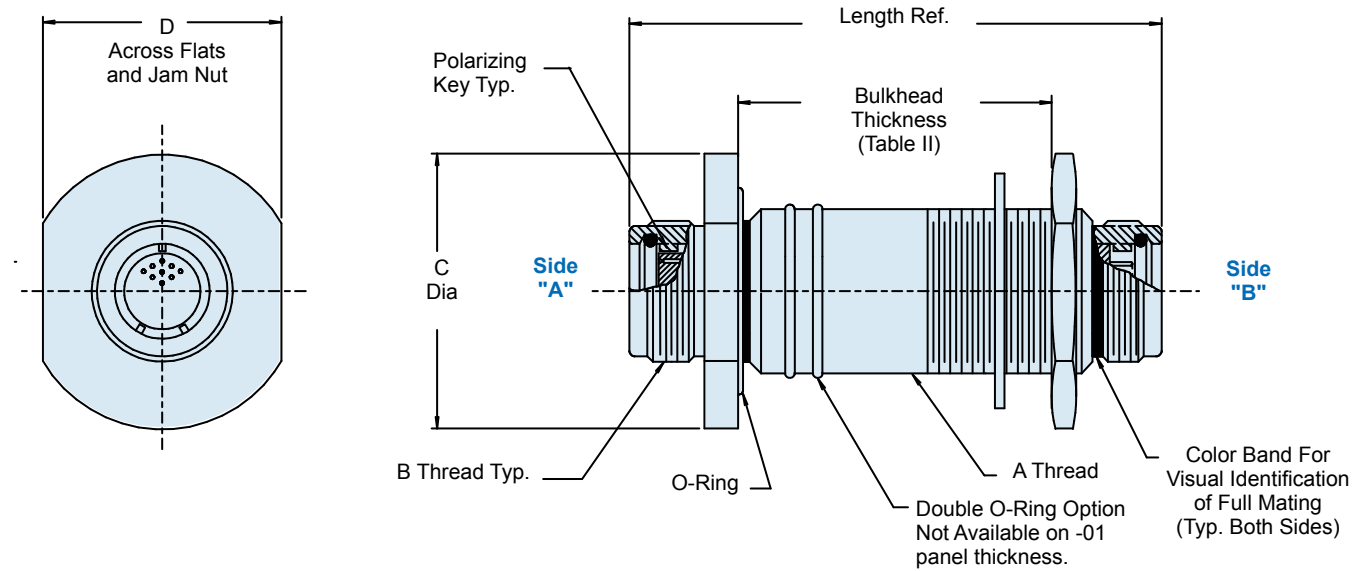
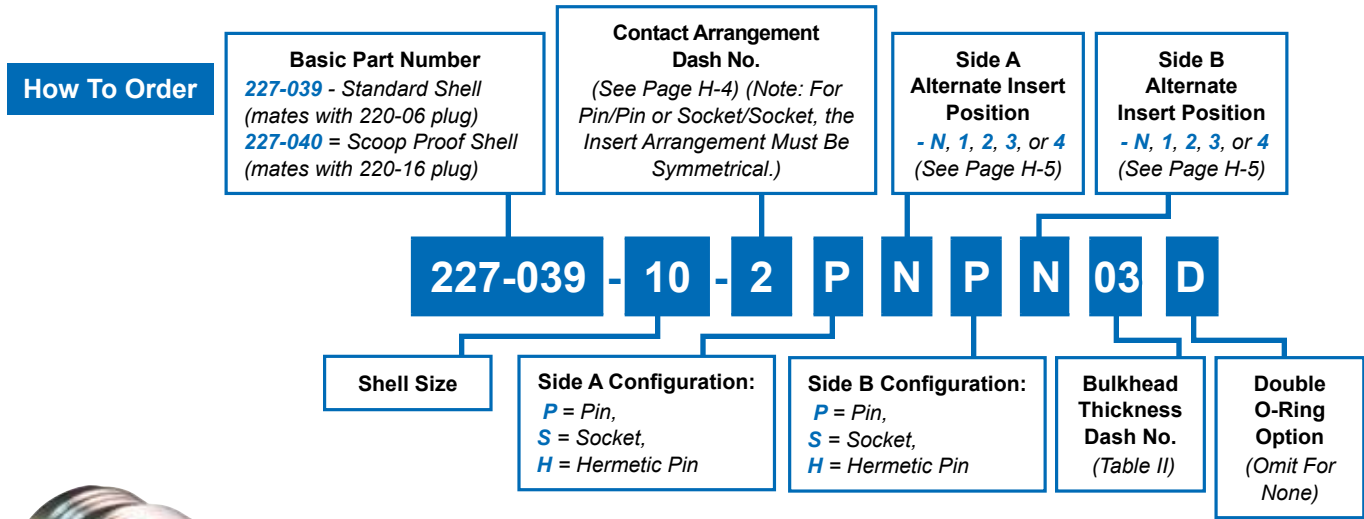

Metric dimensions (mm) are indicated in parentheses

227-039 and 227-040  
**Jam Nut Mount Bulkhead Feed-Through Connector  
 Environmental or Hermetic**



Table I					
Shell Size	A Thread Class 2A	B Thread Class 2A	C Dia	D Flat	E Dia *
10	7/8-20 UNEF	.750-.1P-.1L	1.41 (35.8)	1.250 (31.8)	.875 (22.2)
12	1-20 UNEF	.875-.1P-.1L	1.53 (38.9)	1.375 (34.9)	1.000 (25.4)
14	1 1/8-18 UNEF	1.000-.1P-.1L	1.66 (42.2)	1.500 (38.1)	1.125 (28.6)
16	1 1/4-16 UN	1.125-.1P-.1L	1.78 (45.2)	1.625 (41.3)	1.250 (31.8)
18	1 3/8-16 UN	1.250-.1P-.1L	1.91 (48.5)	1.750 (44.5)	1.375 (34.9)
20	1 1/2-16 UN	1.375-.1P-.1L	2.03 (51.6)	1.875 (47.6)	1.500 (38.1)
22	1 5/8-16 UN	1.500-.1P-.1L	2.16 (54.9)	2.000 (50.8)	1.625 (41.3)
24	1 3/4-16 UN	1.625-.1P-.1L	2.28 (57.9)	2.125 (54.0)	1.750 (44.5)

\* Standard Shell  $+.010 (.3) -.000 (.0)$   
 \* Double "O" Ring Option  $+.002 (.3) -.000 (.0)$

Table II				
Dash No.	Panel Min	Panel Max	Length (Ref.)	
			Standard Shell Length	Scoop Proof Shell Length
01	.03 (.8)	1.00 (25.4)	2.30 (58.4)	3.00 (76.2)
02	1.00 (25.4)	2.00 (50.8)	3.30 (83.8)	4.00 (101.6)
03	2.00 (50.8)	3.00 (76.2)	4.30 (109.2)	5.00 (127.0)
04	3.00 (76.2)	4.00 (101.6)	5.30 (134.6)	6.00 (152.4)
05	4.00 (101.6)	5.00 (127.0)	6.30 (160.0)	7.00 (177.8)
06	5.00 (127.0)	6.00 (152.4)	7.30 (185.4)	8.00 (203.2)
07	6.00 (152.4)	7.00 (177.8)	8.30 (210.8)	9.00 (228.6)
08	7.00 (177.8)	8.00 (203.2)	9.30 (236.2)	10.00 (254.0)

**Notes**

1. Open face pressure rating: 1000 to 5000 psi, hermetic side
2. Power to a given contact on one end will result in power to the contact directly opposite, regardless of contact I.D.

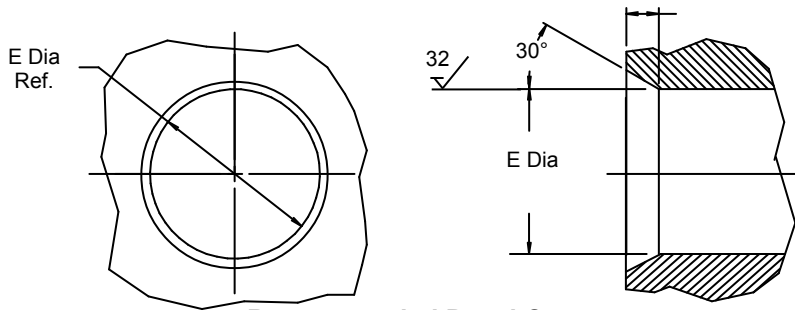

**Recommended Panel Cutout**

Metric dimensions (mm) are indicated in parentheses



SERIES 28  
HIPER-D

# MIL-DTL-24308/9

*QPL and Glenair Commercial  
D-Subminiature Hermetic Connectors*

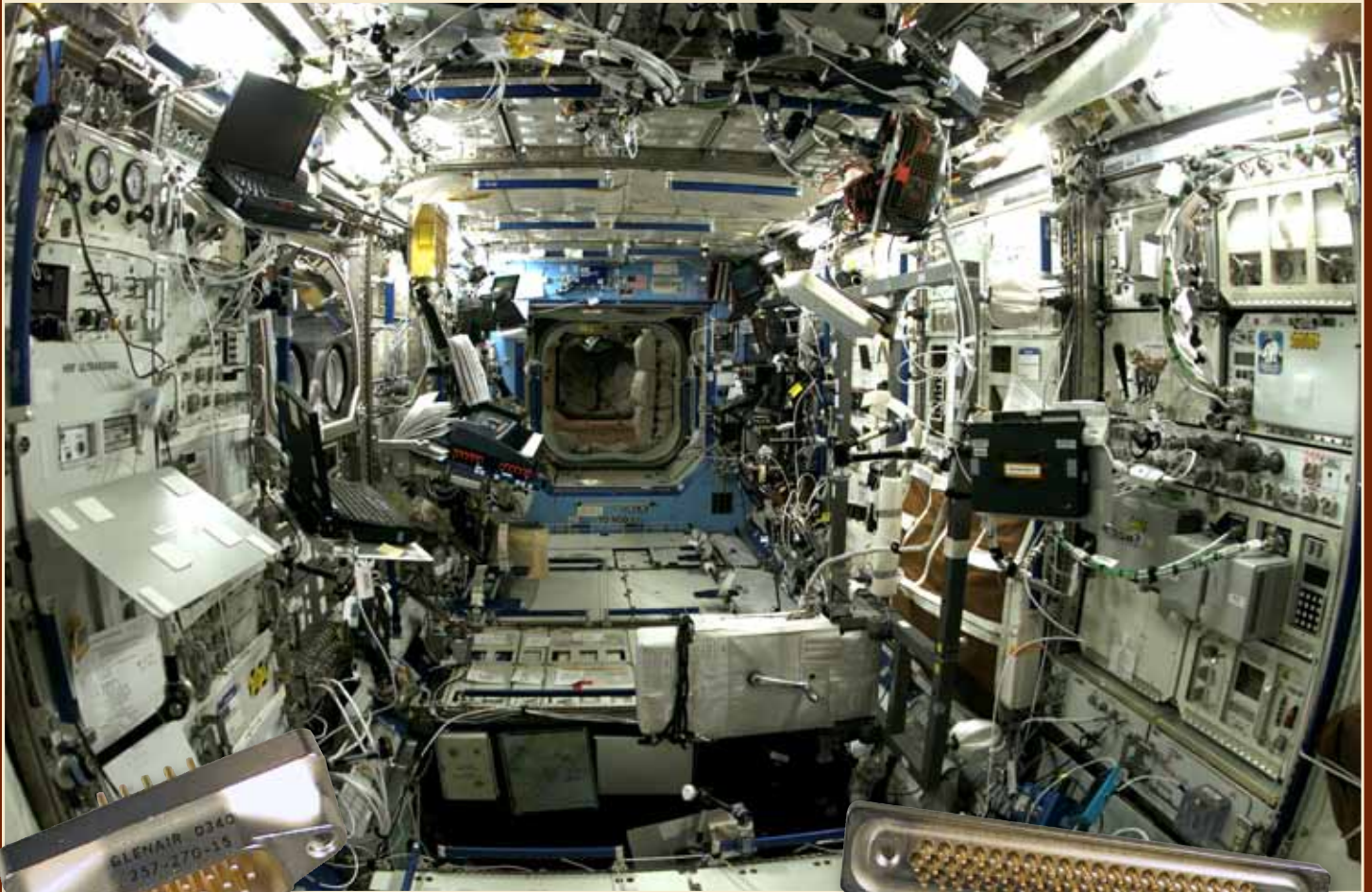

**G**lenair MIL-DTL-24308 D-Subminiature hermetic connectors are high density, compact connectors suited for use in rack and panel, cable to panel and cable to cable applications where an airtight seal is required. Front- and rear-mount shell styles are available with both solder cup and eyelet contacts in six shell sizes for maximum design flexibility. Because Glenair makes all its hermetic connectors in-house, including the machining of shells, molding of interfacial seals and firing of hermetic components, we can offer you outstanding availability on stock products and fast turnaround on special orders.

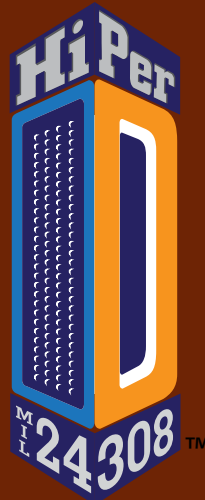

**Glenair**®

Glenair, Inc.  
1211 Air Way  
Glendale, CA  
91201-2497  
818-247-6000  
sales@glenair.com  
www.glenair.com

**MIL-DTL-24308**  
**D-Subminiature Hermetic Connectors**  
**Introduction**



**MIL-DTL-24308/9 and Glenair Commercial Hermetic D-Subminiature Connectors**

**D-Subminiature hermetic connectors** are offered with passivated stainless steel, fused tin and nickel plated shells, with glass insulators fused to the connector shell. Ferrous alloy gold-plated contacts, available in sizes #20 and #22 contacts—on standard and high-density arrangements, respectively—meet a leak rate of  $1 \times 10^{-7}$

cc/Helium per second, excepting 280-006/MIL-DTL-24308 parts and 280-035 ( $1 \times 10^{-8}$ ), Kovar™. Choose from 11 different insert arrangements with 9 to 104 circuits, in accordance with MIL-DTL-24308/9H and Glenair commercial series. Connectors with panel sealing are available with nitrile, fluorosilicone and silicone O-rings.

Quick Selection Guide		
Part Number	Description	Page
	MIL-DTL-24308 Type Hermetic Connector Solder Mount Information	J-2
	Glenair Hermetic Connector Products Space Grade Mod Codes	J-3
	MIL-DTL-24308 Hermetic Connector Materials, Finishes and Specifications	J-4
	MIL-DTL-24308 Type Hermetic Connector Insert Arrangements and Panel Cut-Outs	J-5
	MIL-DTL-24308 Type Hermetic Connector Style A and Style B Dimensions	J-6
<b>280-003</b>	Glass Sealed D-Subminiature Receptacle	J-7
<b>280-006</b>	Glass Sealed D-Subminiature Receptacle	J-9
<b>280-104</b>	Glass Sealed D-Subminiature Receptacle	J-11
<b>280-012</b>	Rear PCB Termination Glass Sealed D-Subminiature Connector	J-13
<b>280-013</b>	O-Ring Panel Sealing D-Subminiature Connector	J-15
<b>280-014</b>	O-Ring Panel Sealing D-Subminiature Connector	J-17
<b>287-018</b>	Glass-Sealed D-Subminiature Connector with Front Mount O-Ring Seal	J-19
<b>287-035</b>	High Density Glass-Sealed D-Subminiature Connector	J-21
<b>287-159</b>	Hermetic D-Subminiature Connector, Bulkhead Feedthrough, O-Ring Seal	J-23
<b>287-450</b>	Hermetic D-Subminiature Connector, Rear-Mount, O-Ring Seal	J-25

Dimensions in Inches (millimeters) are subject to change without notice.





**MIL-DTL-24308**  
**D-Subminiature Hermetic Connectors**  
**Solder Mount Flange, Contact Style and Shell Plating Options**

**Style A**



**Style B**



Glass-sealed hermetic receptacles are qualified to MIL-DTL-24308/9 and feature gold-plated iron alloy size #20 contacts and steel shells. Available in six shell sizes, these connectors are installed onto bulkheads by soldering. Choose solder cup or eyelet contacts for termination to #20 AWG wire. Choose Class H tin-plated steel shells for general purpose applications. For space applications choose Class K versions with nickel-plated stainless steel shells.

**Flange Style A**

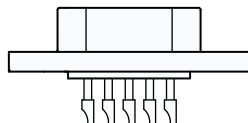

Solid connector flange with no mounting hole.

**Flange Style B**

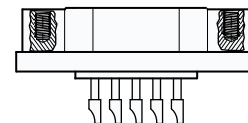

Connector flange features integral tapped #4-40 female threads for attaching mating male screw locks.

**Contact Style P**

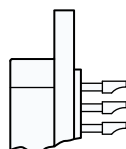

Connector is supplied with solder cup contacts.

**Contact Style X**

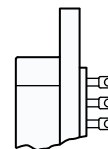

Connector is supplied with eyelet style contacts.

J

Shell Size	No. of Contacts	Contact Style	Flange Style	Class H Tin-Plated Steel		Class K (Space) Nickel-Plated Stainless Steel	
				Part Number	Military PN	Part Number	Military PN*
1	9	Solder Cup	A	<a href="#">280-006H1AP</a>	M24308/9-1	<a href="#">280-006K1AP</a>	M24308/9-21
1	9	Solder Cup	B	<a href="#">280-006H1BP</a>	M24308/9-11	<a href="#">280-006K1BP</a>	M24308/9-31
1	9	Eyelet	A	<a href="#">280-006H1AX</a>	M24308/9-6	<a href="#">280-006K1AX</a>	M24308/9-26
1	9	Eyelet	B	<a href="#">280-006H1BX</a>	M24308/9-16	<a href="#">280-006K1BX</a>	M24308/9-36
2	15	Solder Cup	A	<a href="#">280-006H2AP</a>	M24308/9-2	<a href="#">280-006K2AP</a>	M24308/9-22
2	15	Solder Cup	B	<a href="#">280-006H2BP</a>	M24308/9-12	<a href="#">280-006K2BP</a>	M24308/9-32
2	15	Eyelet	A	<a href="#">280-006H2AX</a>	M24308/9-7	<a href="#">280-006K2AX</a>	M24308/9-27
2	15	Eyelet	B	<a href="#">280-006H2BX</a>	M24308/9-17	<a href="#">280-006K2BX</a>	M24308/9-37
3	25	Solder Cup	A	<a href="#">280-006H3AP</a>	M24308/9-3	<a href="#">280-006K3AP</a>	M24308/9-23
3	25	Solder Cup	B	<a href="#">280-006H3BP</a>	M24308/9-13	<a href="#">280-006K3BP</a>	M24308/9-33
3	25	Eyelet	A	<a href="#">280-006H3AX</a>	M24308/9-8	<a href="#">280-006K3AX</a>	M24308/9-28
3	25	Eyelet	B	<a href="#">280-006H3BX</a>	M24308/9-18	<a href="#">280-006K3BX</a>	M24308/9-38
4	37	Solder Cup	A	<a href="#">280-006H4AP</a>	M24308/9-4	<a href="#">280-006K4AP</a>	M24308/9-24
4	37	Solder Cup	B	<a href="#">280-006H4BP</a>	M24308/9-14	<a href="#">280-006K4BP</a>	M24308/9-34
4	37	Eyelet	A	<a href="#">280-006H4AX</a>	M24308/9-9	<a href="#">280-006K4AX</a>	M24308/9-29
4	37	Eyelet	B	<a href="#">280-006H4BX</a>	M24308/9-19	<a href="#">280-006K4BX</a>	M24308/9-39
5	50	Solder Cup	A	<a href="#">280-006H5AP</a>	M24308/9-5	<a href="#">280-006K5AP</a>	M24308/9-25
5	50	Solder Cup	B	<a href="#">280-006H5BP</a>	M24308/9-15	<a href="#">280-006K5BP</a>	M24308/9-35
5	50	Eyelet	A	<a href="#">280-006H5AX</a>	M24308/9-10	<a href="#">280-006K5AX</a>	M24308/9-30
5	50	Eyelet	B	<a href="#">280-006H5BX</a>	M24308/9-20	<a href="#">280-006K5BX</a>	M24308/9-40

\*For Reference Only

Dimensions in Inches (millimeters) are subject to change without notice.

# Glenair Hermetic Connector Products Space Grade Mod Codes



MIL-DTL-24308  
Type

J

## What is outgassing?

Plastic and rubber materials give off gaseous molecules. For example, the smell inside a new car is caused by polymer outgassing. Heat and vacuum increase the rate of diffusion. In a spacecraft the gases coming off polymers can contaminate optical surfaces and instruments. The result is degraded performance.

## How is outgassing measured?

The space industry has adopted a standardized test procedure, **ASTM E 595**, to evaluate out-gassing properties of polymers. Small samples of material are heated to 125° C. at a vacuum of  $5 \times 10^{-5}$  torr for 24 hours. Then the sample is weighed to calculate the **Total Mass Loss** (TML). The TML cannot exceed 1.00% of the total initial mass. During the test, outgassed matter condenses on a cooled collector plate. The quantity of outgassed matter is calculated to determine the **Collected Volatile Condensable Material** (CVCN). The CVCN cannot exceed 0.10% of the original specimen mass.

## What is NASA screening?

NASA specification EEE-INST-002 provides instructions on selecting, screening and qualifying parts for use on NASA GSFC space flight projects.

## What screening level is required?

NASA defines three levels of screening: level 1 for highest reliability, level 2 for high reliability, and level 3 for standard reliability. Level 3 equates to standard lot acceptance inspection. Levels 1 and 2 call for additional testing.

## HOW TO ORDER SPACE GRADE CONNECTORS

### Step 1: Find a Standard Part Number

Electroless nickel plated shells are preferred for space flight. Cadmium plating is prohibited.

### Step 2: Select a NASA Screening Level

The term "Screening Level" refers to the final inspection procedure.

**Level 1** for mission-critical highest reliability

**Level 2** for high reliability

**Level 3** for standard reliability

### Step 3: Choose Outgassing Processing

A detailed explanation of outgassing is on the following pages. The fluorosilicone rubber seals commonly used on aerospace-grade connectors such as MIL-DTL-38999 and Series 79 connectors, along with certain bonding agents and inks, do not meet NASA outgassing requirements unless the connector is specially processed. Glenair outgassing tests have shown oven baking or thermal vacuum outgassing processing are sufficient to reduce outgassing levels to NASA standards. Oven baking is more economical than thermal vacuum outgassing.

### Step 4: Select the Mod 429 Code that Matches the Desired Level of Screening and Outgassing

Use the following table to choose the right modification code. Add the mod code to the connector part number. Example: 790-024PC-13ML-**429C**

## NASA SCREENING LEVELS AND MODIFICATION CODES

NASA Screening Level	Special Screening Only	Special Screening Plus Outgassing Processing	
		8 Hour Oven Bake 400° F.	Thermal Vacuum Outgassing 24 hrs. 125° C.
Level 1 Highest Reliability	Mod 429B	Mod 429J	Mod 429C
Level 2 High Reliability	Mod 429	Mod 429K	Mod 429A
Level 3 Standard Reliability	(Use standard part number)	Mod 186	Mod 186M

Dimensions in Inches (millimeters) are subject to change without notice.

© 2013 Glenair, Inc.

U.S. CAGE Code 06324

Printed in U.S.A.



## MIL-DTL-24308 Type D-Subminiature Hermetic Connectors Materials, Finishes and Specifications

### MATERIALS AND FINISHES

Contacts	Ferrous alloy, gold plated per ASTM B488, type II, code C, class 1,27.
Shell, class H	Carbon steel, tin/lead plated over nickel underplating (3% min. lead)*
Shell, class K	304L alloy stainless steel, dull nickel plated
Insulators	Vitreous glass

### SPECIFICATIONS

Property	Standard Density (#20)	High Density (#22)
Current rating	5 Amps per contact maximum	3 Amps per contact maximum
Voltage rating (DWV)	70,000 ft. (21,336 meters)	500 VAC sea level
Voltage rating (DWV)	175 VAC 70,000 (21,336 m)	115 VAC 70,000 (21,336 m)
Insulation resistance	5 gigaohms minimum @ 500 VDC	
Hermeticity	meets or exceeds requirement of MIL-DTL-24308	
Contact resistance	165 milliohms maximum	
Thermal vacuum outgassing (class K)	1.0% max. TML , 0.1% max. CVCM	
Durability	500 mating cycles	
Operating temperature	-55 (+0/-3)° C to +125 (+3/-0)° C*	
Shock	50 g.	
Vibration	20 g.	
Corrosion resistance (salt spray)	48 hours	
Maximum wire size	#20 AWG	#22 AWG

\* For O-ring sealing type, refer to Table I for temperature range limitations

### TABLE I

Elastomer	O-Ring Temperature Range	Assembly Temperature Range
Viton	-26°C to 205°C (-15°F to 400°F)	-26°C to 155°C (-15°F to 311°F)
Nitrile	-34°C to 121°C (-30°F to 250°F)	-34°C to 121°C (-30°F to 250°F)
Fluorosilicone	-73°C to 177°C (-100°F to 350°F)	-55°C to 155°C (-67°F to 311°F)
Silicone	-54°C to 232°C (-100°F to 450°F)	-54°C to 155°C (-65°F to 311°F)
EPDM	-57°C to 149°C (-70°F to 300°F)	-55°C to 149°C (-67°F to 300°F)
Neoprene	-37°C to 107°C (-35°F to 225°F)	-37°C to 107°C (-35°F to 225°F)

### Catalog Notes

For all parts in this catalog:

- All parts will be identified with manufacturer's name and part number, space permitting.
- Dimensions are subject to change without notice. Metric dimensions appear in parentheses in diagrams and tables, based on 1 inch = 25.4 mm, for reference only. Unless otherwise specified, the following other dimensional tolerances apply:
 

.xx = ± .03 (0.8)	Lengths = ± .060 (1.52)
.xxx = ± .015 (0.4)	Angles = ± 5°

Customers are advised to consult the factory for the latest specifications, particularly to confirm critical dimensions such as connector lengths, threads, and so on. When errors or mistakes are brought to our attention, corrected content is posted immediately to [www.glenair.com](http://www.glenair.com).

Dimensions in Inches (millimeters) are subject to change without notice.

# MIL-DTL-24308 Type D-Subminiature Hermetic Connectors Insert Arrangements and Panel Cut-Outs



MIL-DTL-24308  
Type

STANDARD INSERT ARRANGEMENTS (#20 CONTACTS)		
SHELL SIZE	NUMBER OF CONTACTS	MATING FACE OF CONNECTOR
1	9	
2	15	
3	25	
4	37	
5	50	

PANEL CUTOUTS				
The cutout shown is for front-panel mounting of flange style A and B.				
Shell Size	A		B	
	In.	mm.	In.	mm.
1	± .005	± 0.13	± .005	± 0.13
2	.745	18.92	.385	9.78
3	.950	24.13	.385	9.78
4	1.495	37.97	.385	9.78
5	2.145	54.48	.520	13.21

Front-Mounted  
Connector  
Installed on  
Bulkhead

J

HIGH DENSITY INSERT ARRANGEMENTS (#22 CONTACTS)		
SHELL SIZE	NUMBER OF CONTACTS	MATING FACE OF CONNECTOR
1	15	
2	26	
3	44	
4	62	
5	78	
6	104	

**SOLDER CUP ORIENTATION**

Sizes 1-4

Size 5

Size 6

Dimensions in Inches (millimeters) are subject to change without notice.



# MIL-DTL-24308

## D-Subminiature Hermetic Connectors

### Style A and Style B Dimensions

#### Dimensions for Flange Style A

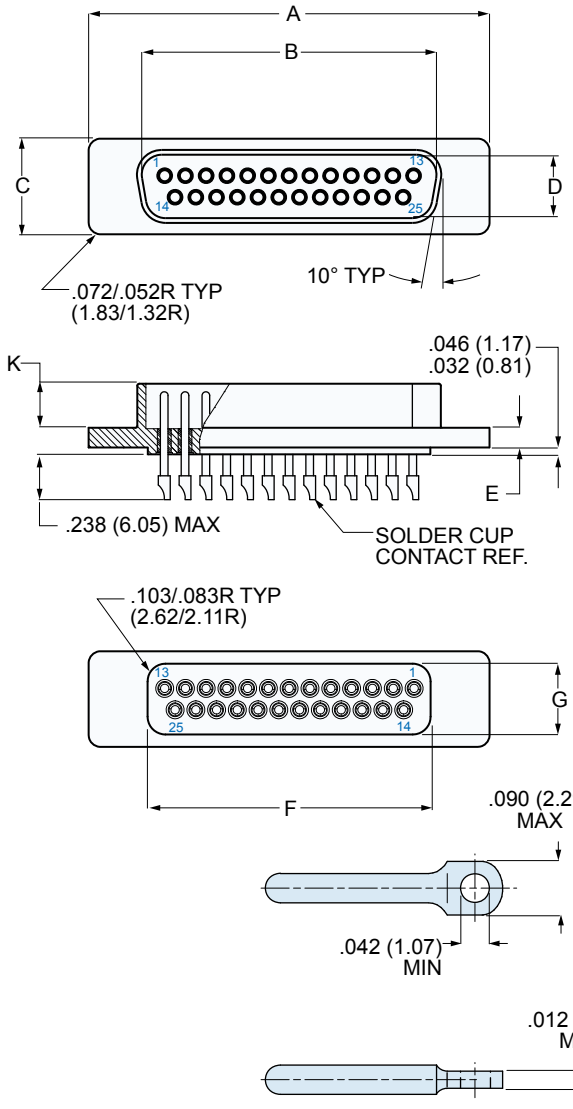

#### Dimensions for Flange Style B

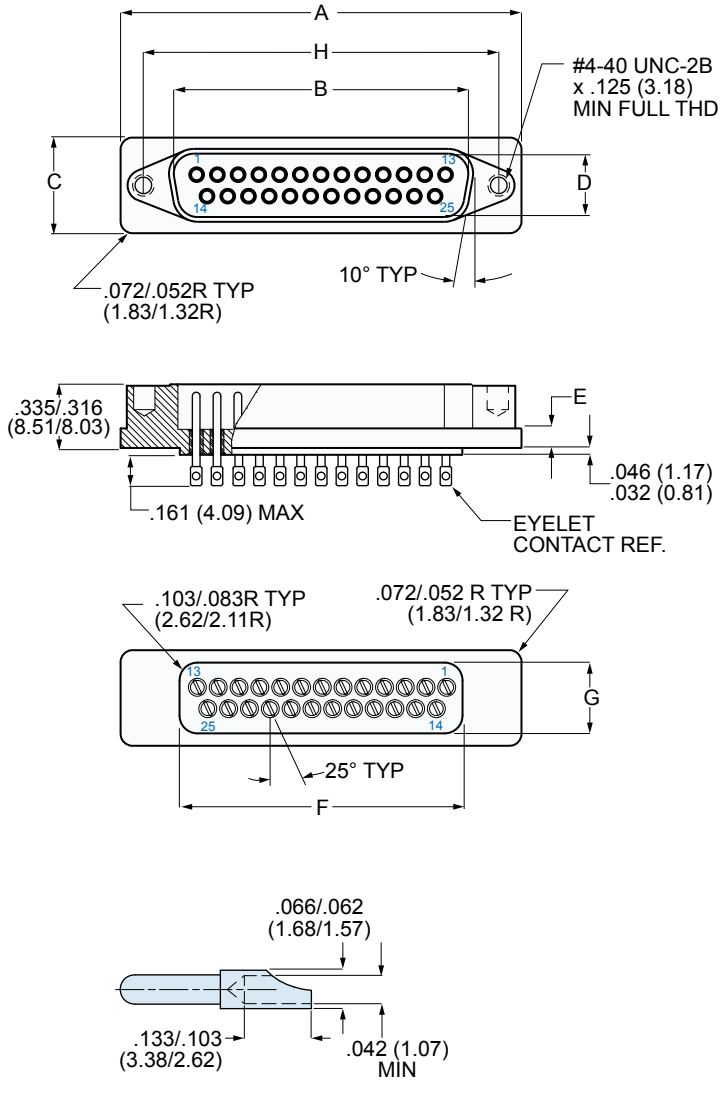

J

Shell Size	A		B		C		D		E		F		G		H		K	
	In.	mm.	In.	mm.	In.	mm.	In.	mm.	In.	mm.	In.	mm.	In.	mm.	In.	mm.	In.	mm.
	±	±	±	±	±	±	±	±	±	±	±	±	±	±	±	±	±	±
1	1.213	30.81	.667	16.94	.498	12.65	.330	8.38	.094	2.39	.725	18.42	.369	9.37	.984	24.99	.235	5.97
2	1.541	39.14	.993	25.22	.498	12.65	.330	8.38	.094	2.39	.932	23.67	.369	9.37	1.312	33.32	.235	5.97
3	2.088	53.04	1.535	38.99	.498	12.65	.330	8.38	.103	2.62	1.479	37.57	.369	9.37	1.852	47.04	.230	5.84
4	2.729	69.32	2.183	55.45	.498	12.65	.330	8.38	.103	2.62	2.125	53.98	.369	9.37	2.500	63.50	.230	5.84
5	2.635	66.93	2.079	52.81	.610	15.49	.441	11.20	.103	2.62	2.000	50.80	.500	12.70	2.406	61.11	.230	5.84

Dimensions in Inches (millimeters) are subject to change without notice.

**280-003**  
**MIL-DTL-24308/9 Type Hermetic**  
**Glass-Sealed D-Subminiature Receptacle**



MIL-DTL-24308  
Type

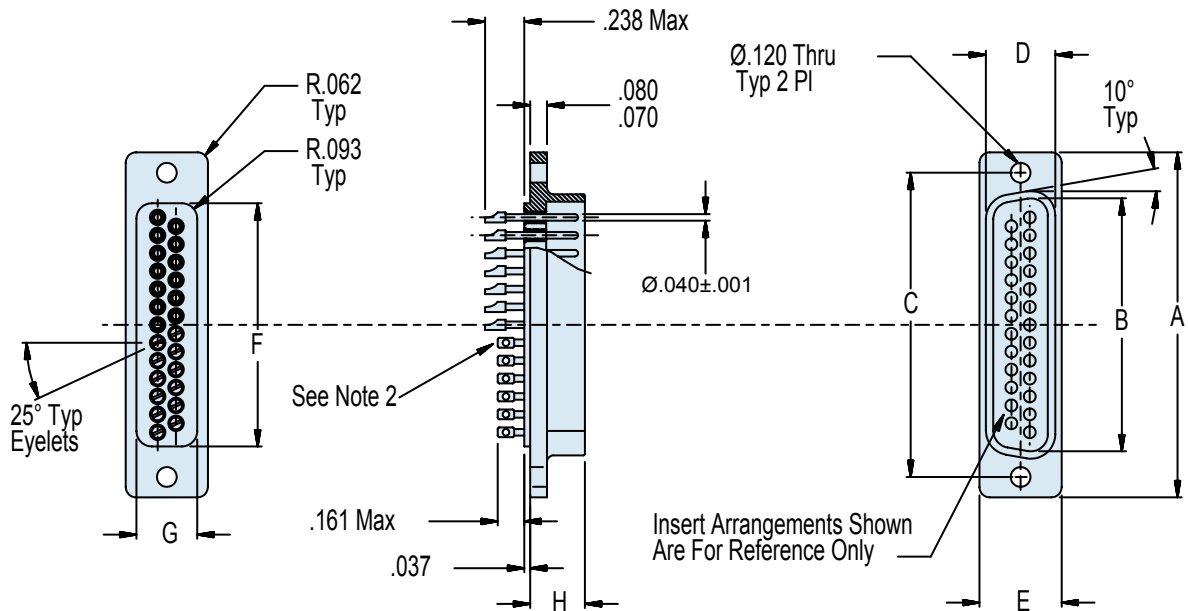
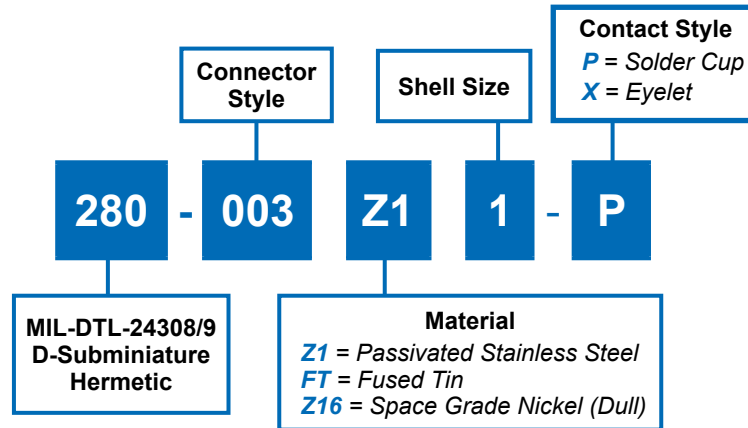

**APPLICATION NOTES**

- To be identified with manufacturer's name, part number and date code, space permitting.
- Contact Style: Eyelet or Solder Cup (See Part Number Development)
- Material/Finish:  
 Shell: Z1 = Stainless steel/passivated.  
 FT = Cold rolled steel/fused tin plate.  
 Z16 = Stainless steel/nickel plated, dull finish
- Insulators - Glass bead/N.A.
- Contacts: Pins, Alloy 52/gold plated
- Metric Dimensions (mm) are indicated in parentheses.
- Test Criteria:
  - Hermeticity:  $1 \times 10^{-7}$  ccHe/sec@ 1 ATM delta pressure
  - DWV: 750 VAC pin to shell without breakdown
  - Insulation Resistance: 5000 megohms min @ 500 VDC

Dimensions in Inches (millimeters) are subject to change without notice.



**280-003**  
**MIL-DTL-24308/9 Type Hermetic**  
**Glass-Sealed D-Subminiature Receptacle**

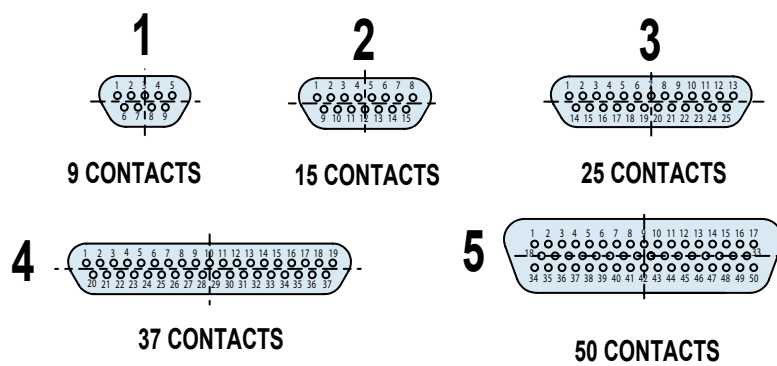

**TABLE I: CONNECTOR DIMENSIONS**

Shell Size	Dim A ± .010 (± 0.3)	Dim B ± .004 (± 0.1)	Dim C ± .005 (± 0.1)	Dim D ± .010 (± 0.3)	Dim E ± .010 (± 0.3)	Dim F ± .010 (± 0.3)	Dim G ± .010 (± 0.3)	Dim H ± .015 (± 0.4)
1	1.208 (30.7)	.667 (16.9)	.984 (25.0)	.366 (9.3)	.498 (12.6)	.725 (18.4)	.369 (9.4)	.334 (8.5)
2	1.545 (39.1)	.993 (25.2)	1.312 (33.3)	.366 (9.3)	.498 (12.6)	.932 (23.7)	.369 (9.4)	.334 (8.5)
3	2.093 (53.1)	1.535 (39.0)	1.852 (47.0)	.384 (9.8)	.498 (12.6)	1.479 (37.6)	.369 (9.4)	.334 (8.5)
4	2.733 (69.3)	2.183 (55.4)	2.500 (63.5)	.384 (9.8)	.498 (12.6)	2.125 (54.0)	.369 (9.4)	.334 (8.5)
5	2.640 (67.0)	2.079 (52.8)	2.406 (61.1)	.490 (12.4)	.610 (15.5)	2.000 (50.8)	.500 (12.7)	.334 (8.5)

Dimensions in Inches (millimeters) are subject to change without notice.



**280-006**  
**MIL-DTL-24308/9 Hermetic**  
**Glass-Sealed D-Subminiature Receptacle**



MIL-DTL-24308  
Type

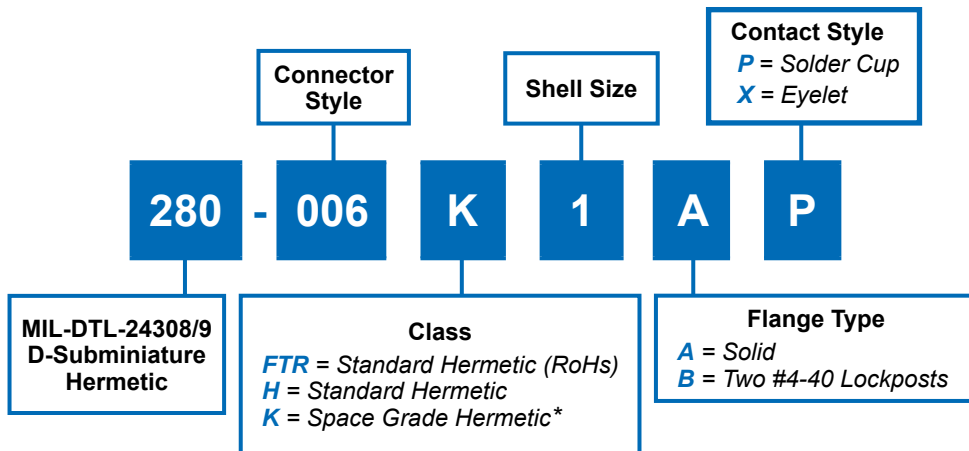

\* NOT a QPL Product

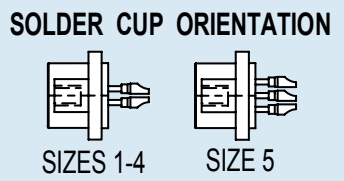
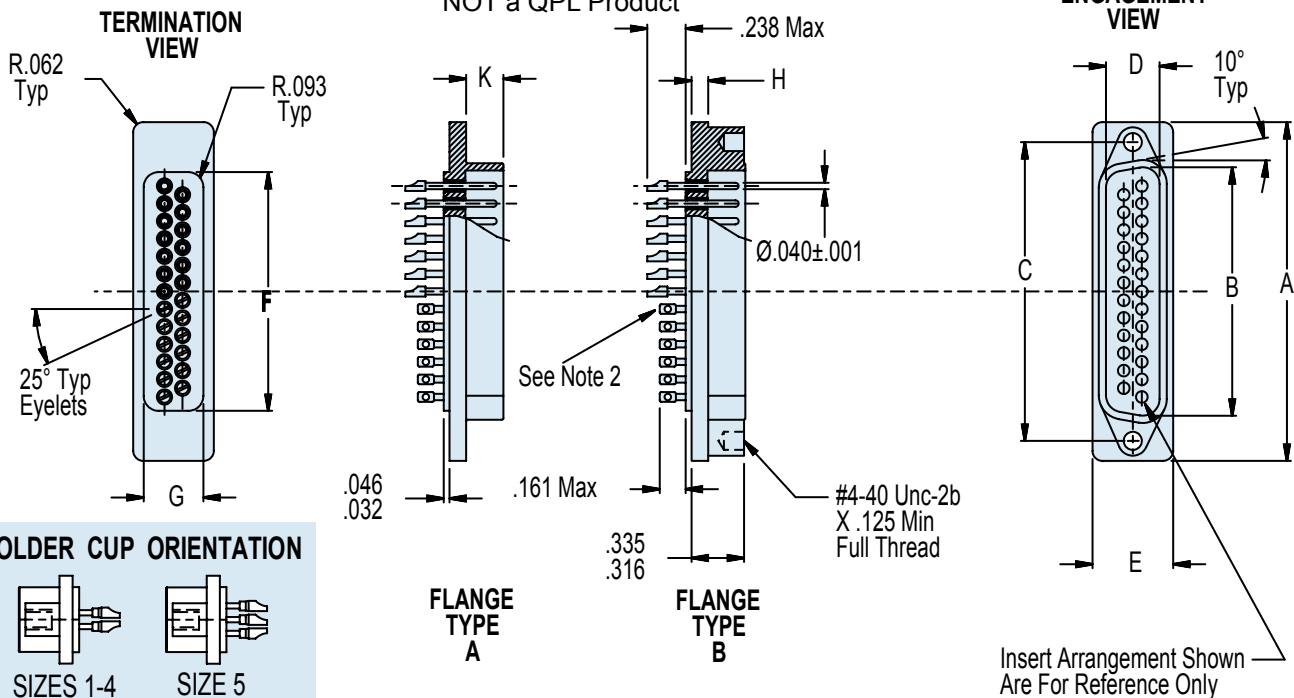

**APPLICATION NOTES**

- To be identified with manufacturer's name, part number and date code, space permitting.
- Contact Style: Eyelet or Solder Cup (See Part Number Development).
- Material/Finish:  
 Shell: H = FT - Carbon steel/tin plate.  
 K = Z16 = Stainless steel/nickel plated, dull finish.  
 FTR = Carbon steel/tin fused (RoHs compliant)  
 Insulators: Glass bead/N.A.  
 Contacts: Pins, Alloy 52/gold plated
- Performance:  
 DWV - 750 VAC Pin-to-Shell  
 I.R. - 5,000 MegOhms Min @ 500 VDC  
 Hermeticity <math>1.04 \times 10^{-5}</math> cc He/sec @ 1 atmosphere differential
- Glenair 280-006 will mate with any QPL MIL-DTL-24308/1, /2 and /23 receptacle of the same size and arrangement.
- All dimensions are typical for flange types "A" and "B". "C" dim is not applicable to flange type "A".
- Metric dimensions (mm) are indicated in parentheses.

Dimensions in Inches (millimeters) are subject to change without notice.



**280-006**  
**MIL-DTL-24308/9 Hermetic**  
**Glass-Sealed D-Subminiature Receptacle**

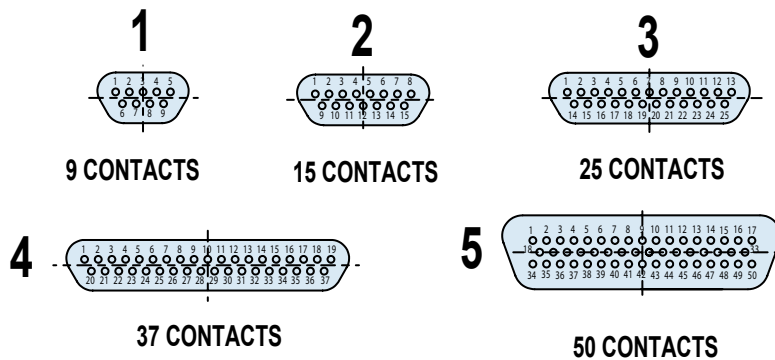

**TABLE I: CONNECTOR DIMENSIONS**

Shell Size	Dim A ± .015 (± 0.4)	Dim B ± .004 (± 0.1)	Dim C ± .005 (± 0.1)	Dim D ± .004 (± 0.1)	Dim E ± .010 (± 0.3)	Dim F ± .010 (± 0.3)	Dim G ± .010 (± 0.3)	Dim H ± .010 (± 0.3)	Dim K ± .006 (± 0.2)
<b>1</b>	1.213 (30.8)	.667 (16.9)	.984 (25.0)	.330 (8.4)	.498 (12.6)	.725 (18.4)	.369 (9.4)	.094 (2.4)	.235 (6.0)
<b>2</b>	1.541 (39.1)	.993 (25.2)	1.312 (33.3)	.330 (8.4)	.498 (12.6)	.932 (23.7)	.369 (9.4)	.094 (2.4)	.235 (6.0)
<b>3</b>	2.088 (53.1)	1.535 (39.0)	1.852 (47.0)	.330 (8.4)	.498 (12.6)	1.479 (37.6)	.369 (9.4)	.103 (2.6)	.230 (5.8)
<b>4</b>	2.729 (69.3)	2.183 (55.4)	2.500 (63.5)	.330 (8.4)	.498 (12.6)	2.125 (54.0)	.369 (9.4)	.103 (2.6)	.230 (5.8)
<b>5</b>	2.635 (66.0)	2.079 (52.8)	2.406 (61.1)	.441 (11.2)	.610 (15.5)	2.000 (50.8)	.500 (12.7)	.103 (2.6)	.230 (5.8)

**RECOMMENDED PANEL CUTOUT**  
**SEE TABLE 2**

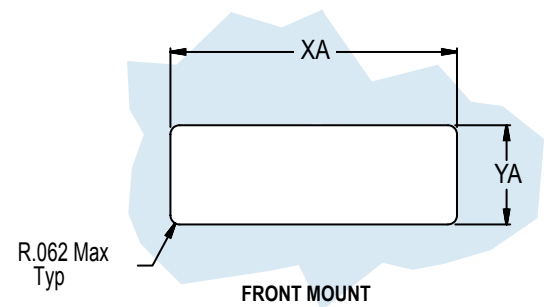

**TABLE II: PANEL CUT-OUT**

Shell Sizes	Style A		Style B		
	Dim XA	Dim YA	Dim XB	Dim YB	Dim C
<b>1</b>	.745 (18.9)	.385 (9.8)	.799 (20.0)	.462 (11.7)	.984 (25.0)
<b>2</b>	.950 (24.1)	.385 (9.8)	1.125 (31.8)	.462 (11.7)	1.312 (33.3)
<b>3</b>	1.495 (38.0)	.385 (9.8)	1.690 (42.9)	.482 (12.2)	1.852 (47.0)
<b>4</b>	2.145 (54.5)	.385 (9.8)	2.335 (59.3)	.482 (12.2)	2.500 (63.5)
<b>5</b>	2.015 (51.2)	.520 (13.2)	2.231 (56.7)	.588 (14.9)	2.406 (61.1)

Dimensions in Inches (millimeters) are subject to change without notice.

**280-104**  
**MIL-DTL-24308/9 Type Hermetic**  
**Glass-Sealed D-Subminiature Receptacle**



MIL-DTL-24308  
Type

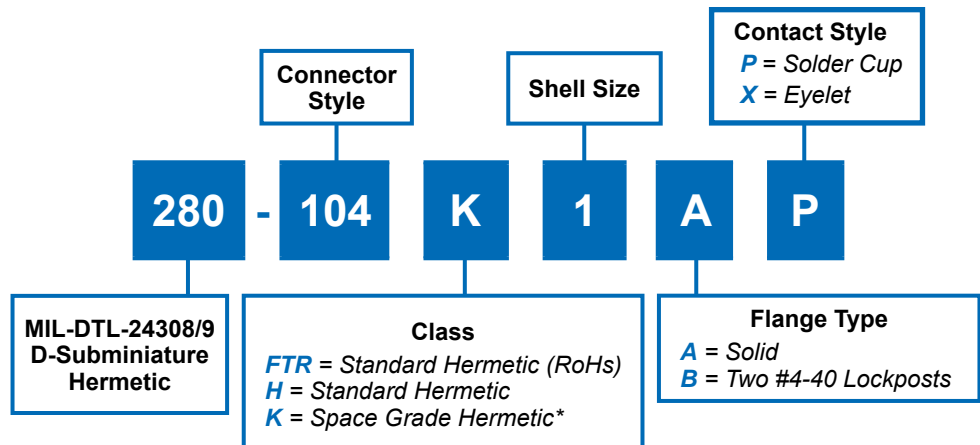

\* NOT a QPL Product

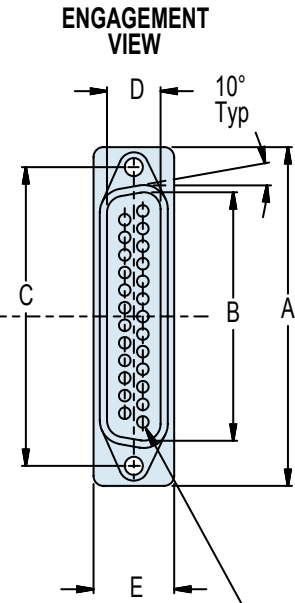
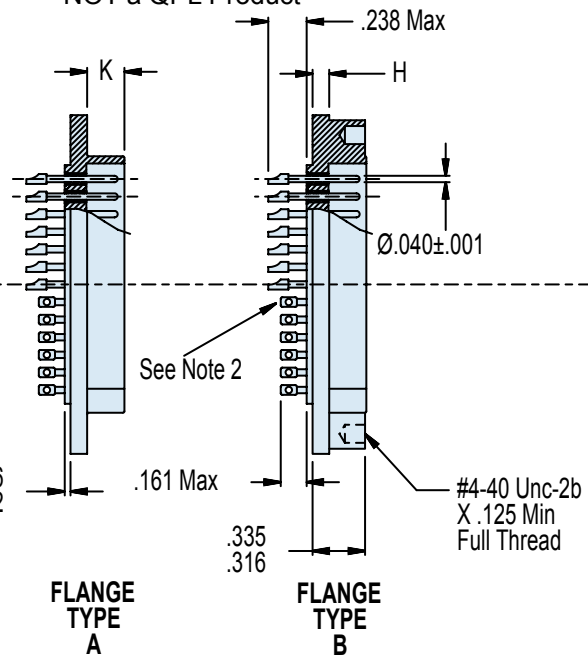
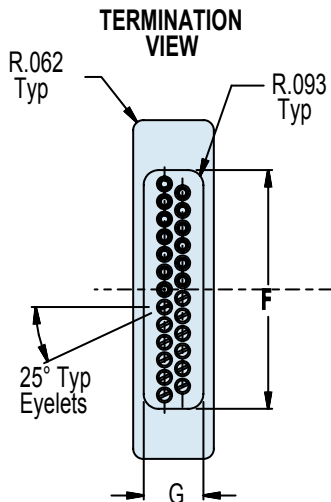

Insert Arrangement Shown Are For Reference Only

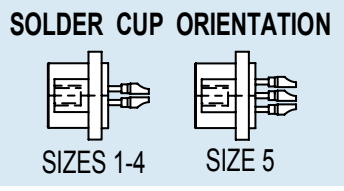

**APPLICATION NOTES**

- To be identified with manufacturer's name, part number and date code, space permitting.
- Contact Style: Eyelet or Solder Cup (See Part Number Development).
- Material/Finish:  
 Shell: H = FT - Carbon steel/tin plate.  
 K = Z16 = Stainless steel/nickel plated, dull finish.  
 FTR = Carbon steel/tin fused (RoHs compliant)  
 Insulators: Glass bead/N.A.  
 Contacts: Pins, Alloy 52/gold plated
- Performance:  
 DWV - 750 VAC Pin-to-Shell  
 I.R. - 5,000 MegOhms Min @ 500 VDC  
 Hermeticity <math>1 \times 10^{-7}</math> cc He/sec @ 1 atmosphere differential
- Glenair 280-104 will mate with any QPL MIL-DTL-24308/1, /2 and /23 receptacle of the same size and arrangement.
- All dimensions are typical for flange types "A" and "B". "C" dim is not applicable to flange type "A".
- Metric dimensions (mm) are indicated in parentheses.

Dimensions in Inches (millimeters) are subject to change without notice.

© 2013 Glenair, Inc.

U.S. CAGE Code 06324

Printed in U.S.A.



**280-104**  
**MIL-DTL-24308/9 Type Hermetic**  
**Glass-Sealed D-Subminiature Receptacle**

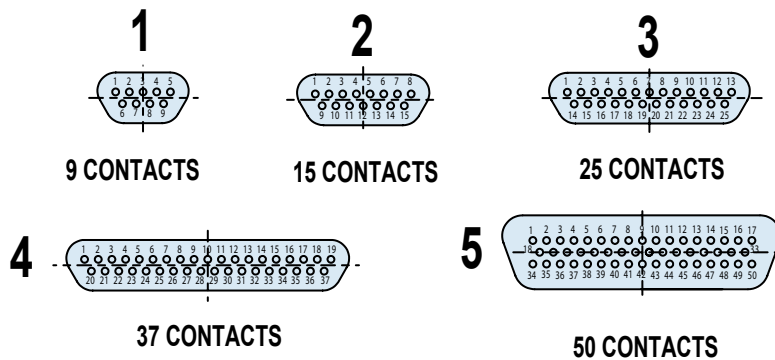

**TABLE I: CONNECTOR DIMENSIONS**

Shell Size	Dim A ± .015 (± 0.4)	Dim B ± .004 (± 0.1)	Dim C ± .005 (± 0.1)	Dim D ± .004 (± 0.1)	Dim E ± .010 (± 0.3)	Dim F ± .010 (± 0.3)	Dim G ± .010 (± 0.3)	Dim H ± .010 (± 0.3)	Dim K ± .006 (± 0.2)
1	1.213 (30.8)	.667 (16.9)	.984 (25.0)	.330 (8.4)	.498 (12.6)	.725 (18.4)	.369 (9.4)	.094 (2.4)	.235 (6.0)
2	1.541 (39.1)	.993 (25.2)	1.312 (33.3)	.330 (8.4)	.498 (12.6)	.932 (23.7)	.369 (9.4)	.094 (2.4)	.235 (6.0)
3	2.088 (53.1)	1.535 (39.0)	1.852 (47.0)	.330 (8.4)	.498 (12.6)	1.479 (37.6)	.369 (9.4)	.103 (2.6)	.230 (5.8)
4	2.729 (69.3)	2.183 (55.4)	2.500 (63.5)	.330 (8.4)	.498 (12.6)	2.125 (54.0)	.369 (9.4)	.103 (2.6)	.230 (5.8)
5	2.635 (66.0)	2.079 (52.8)	2.406 (61.1)	.441 (11.2)	.610 (15.5)	2.000 (50.8)	.500 (12.7)	.103 (2.6)	.230 (5.8)

RECOMMENDED PANEL CUTOUT  
SEE TABLE 2

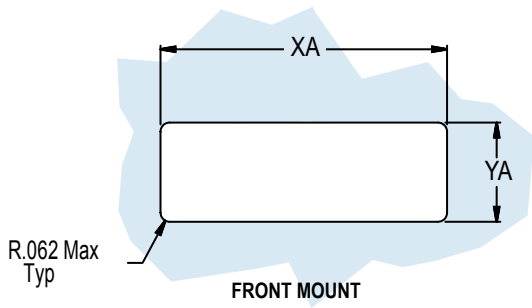

**TABLE II: PANEL CUT-OUT**

Shell Sizes	Style A		Style B		
	Dim XA	Dim YA	Dim XB	Dim YB	Dim C
1	.745 (18.9)	.385 (9.8)	.799 (20.0)	.462 (11.7)	.984 (25.0)
2	.950 (24.1)	.385 (9.8)	1.125 (31.8)	.462 (11.7)	1.312 (33.3)
3	1.495 (38.0)	.385 (9.8)	1.690 (42.9)	.482 (12.2)	1.852 (47.0)
4	2.145 (54.5)	.385 (9.8)	2.335 (59.3)	.482 (12.2)	2.500 (63.5)
5	2.015 (51.2)	.520 (13.2)	2.231 (56.7)	.588 (14.9)	2.406 (61.1)

Dimensions in Inches (millimeters) are subject to change without notice.

**280-012**  
**MIL-DTL-24308/9 Type Hermetic**  
**Rear Printed Circuit Board Termination**  
**Glass-Sealed D-Subminiature Connector**



MIL-DTL-24308  
Type

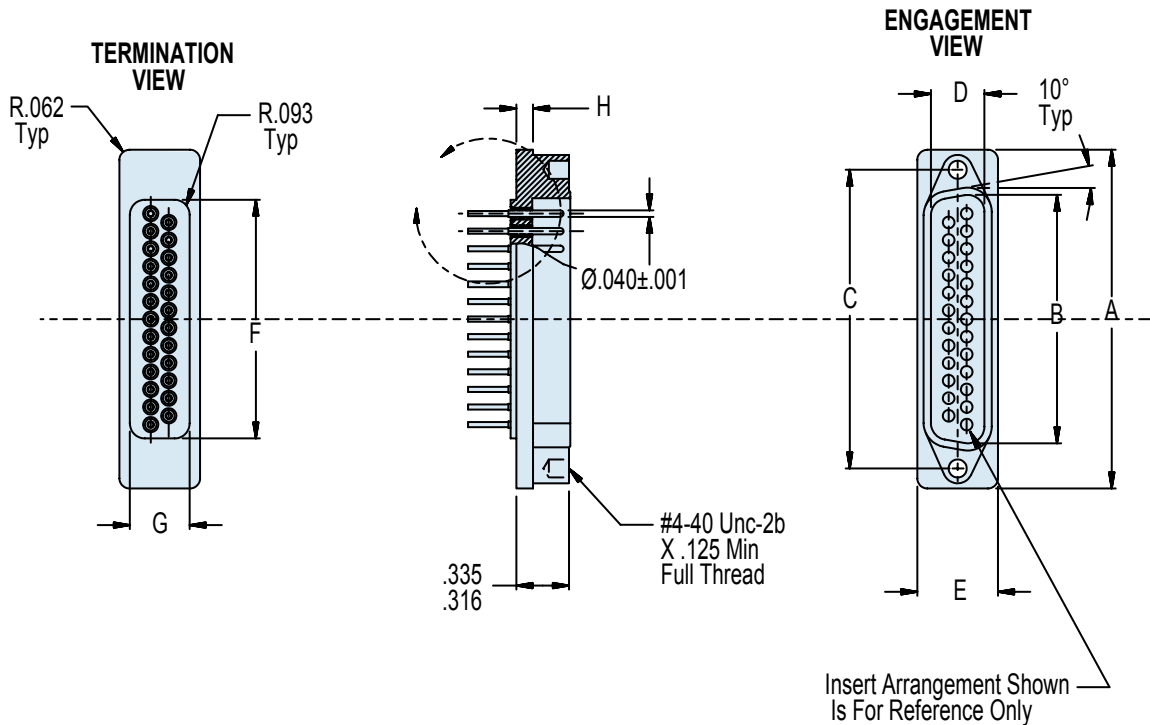
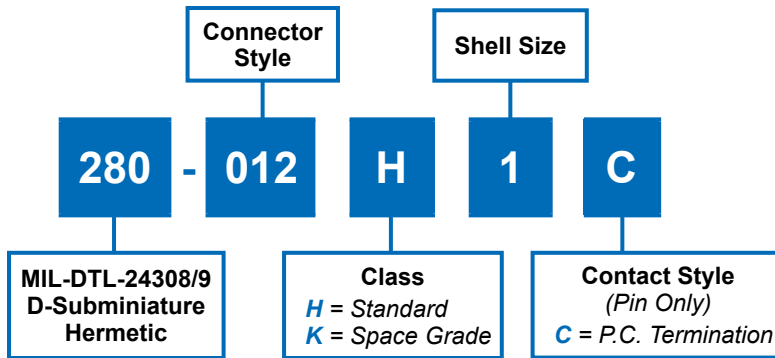

J

**APPLICATION NOTES**

- To be identified with manufacturer's name, part number and date code, space permitting.
- Contact Style: Printed circuit termination only.
- Material/Finish:  
Shell: H = FT - Carbon steel/tin plated.  
K = Z16 - Stainless steel/nickel plated, dull finish.  
Insulators: Glass bead/N.A.  
Contacts: Pins, Alloy 52/gold plated
- Performance:  
DWV - 750 VAC Pin-to-Shell  
I.R. - 5,000 MegOhms Min @ 500 VDC  
Hermeticity -  $1 \times 10^{-7}$  scc He/sec @ 1 atmosphere differential
- Glenair 280-012 will mate with any QPL MIL-DTL-24308/1, /2 and /23 receptacle of the same size and arrangement.
- Metric dimensions (mm) are indicated in parentheses.

Dimensions in Inches (millimeters) are subject to change without notice.



**280-012**  
**MIL-DTL-24308/9 Type Hermetic**  
**Rear Printed Circuit Board Termination**  
**Glass-Sealed D-Subminiature Connector**

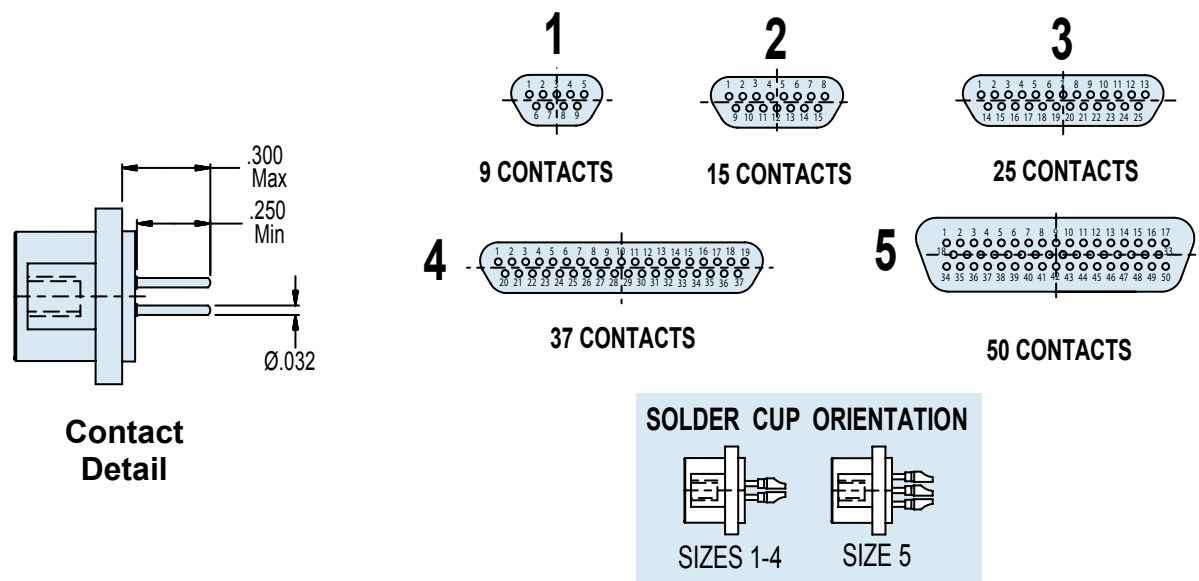

**J**

**TABLE I: CONNECTOR DIMENSIONS**

Shell Size	Dim A ± .015 (± 0.4)	Dim B ± .004 (± 0.1)	Dim C ± .005 (± 0.1)	Dim D ± .004 (± 0.1)	Dim E ± .010 (± 0.3)	Dim F ± .010 (± 0.3)	Dim G ± .010 (± 0.3)	Dim H ± .010 (± 0.3)	Dim K ± .006 (± 0.2)
1	1.213 (30.8)	.667 (16.9)	.984 (25.0)	.330 (8.4)	.498 (12.6)	.725 (18.4)	.369 (9.4)	.094 (2.4)	.235 (6.0)
2	1.541 (39.1)	.993 (25.2)	1.312 (33.3)	.330 (8.4)	.498 (12.6)	.932 (23.7)	.369 (9.4)	.094 (2.4)	.235 (6.0)
3	2.088 (53.0)	1.535 (39.0)	1.852 (47.0)	.330 (8.4)	.498 (12.6)	1.479 (37.6)	.369 (9.4)	.103 (2.6)	.230 (5.8)
4	2.729 (69.3)	2.183 (55.4)	2.500 (63.5)	.330 (8.4)	.498 (12.6)	2.125 (54.0)	.369 (9.4)	.103 (2.6)	.230 (5.8)
5	2.635 (66.9)	2.079 (52.8)	2.406 (61.1)	.441 (11.2)	.610 (15.5)	2.000 (50.8)	.500 (12.7)	.103 (2.6)	.230 (5.8)

**RECOMMENDED PANEL CUTOUT**  
SEE TABLE II

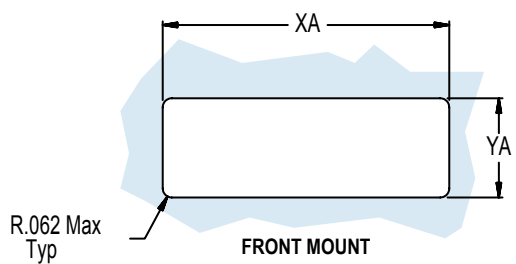

**TABLE II: PANEL CUT-OUT**

Shell Sizes	Style A		Style B		
	Dim XA	Dim YA	Dim XB	Dim YB	Dim C
1	.745 (18.9)	.385 (9.8)	.799 (20.0)	.462 (11.7)	.984 (25.0)
2	.950 (24.1)	.385 (9.8)	1.125 (31.8)	.462 (11.7)	1.312 (33.3)
3	1.495 (38.0)	.385 (9.8)	1.690 (42.9)	.482 (12.2)	1.852 (47.0)
4	2.145 (54.5)	.385 (9.8)	2.335 (59.3)	.482 (12.2)	2.500 (63.5)
5	2.015 (51.2)	.520 (13.2)	2.231 (56.7)	.588 (14.9)	2.406 (61.1)

Dimensions in Inches (millimeters) are subject to change without notice.

**280-013**  
**MIL-DTL-24308/9 Type Hermetic**  
**O-Ring Panel Sealing**  
**Glass-Sealed D-Subminiature High Density Connector**



MIL-DTL-24308  
Type

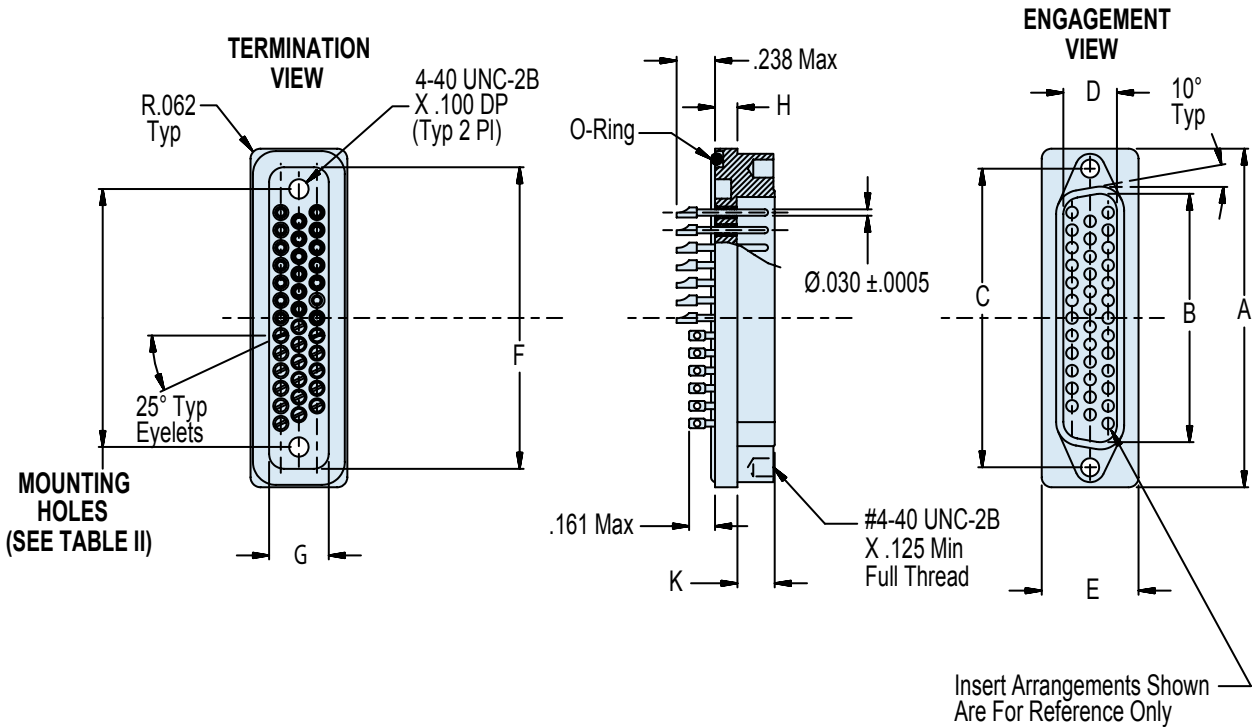
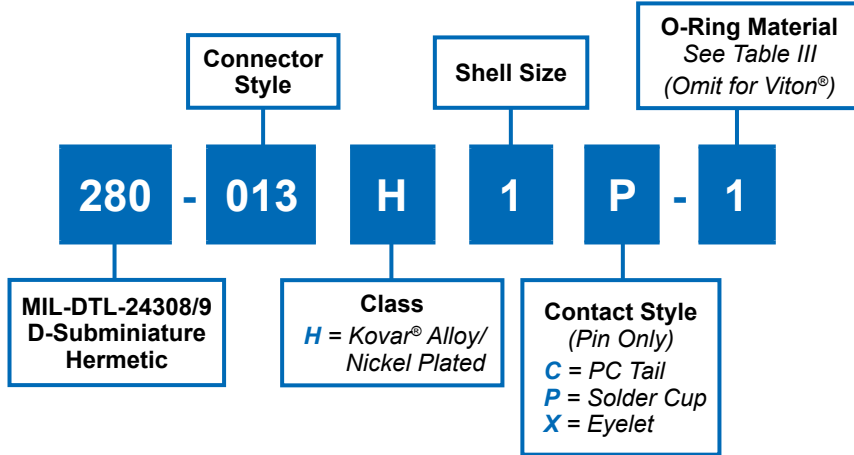

J

**APPLICATION NOTES**

- |  |  |
|--|--|
| <ol style="list-style-type: none"> <li>1. To be identified with manufacturer's name, part number and date code, space permitting.</li> <li>2. Contact Style: Eyelet or solder cup (see part development).</li> <li>3. Material/Finish:<br/>                     Shell: Kovar® alloy/nickel plated.<br/>                     Insulators: Glass bead/N.A.<br/>                     Contacts: Kovar® alloy/gold plated<br/>                     O-Ring: Specify (see Table III)/N.A.</li> </ol> | <ol style="list-style-type: none"> <li>4. Performance:<br/>                     DWV - 500 VAC Pin-to-Shell<br/>                     I.R. - 5,000 MegOhms Min @ 500 VDC<br/>                     Hermeticity - &lt;1 x 10<sup>scc He/sec @ 1x10<sup>-8</sup></sup><br/>                     atmosphere differential</li> <li>5. Glenair 280-013 will mate with any QPL MIL-DTL-24308/1, /2 and /23 receptacle of the same size and arrangement.</li> <li>6. Metric dimensions (mm) are indicated in parentheses.</li> </ol> |
|--|--|

Dimensions in Inches (millimeters) are subject to change without notice.





**280-013**  
**MIL-DTL-24308/9 Type Hermetic**  
**O-Ring Panel Sealing**  
**Glass-Sealed D-Subminiature High Density Connector**

**TABLE III: O-RING MATERIAL**

Dash Number	Material
None	Viton®
-1	Nitrile
-2	Fluorosilicone
-3	Silicone

**CONTACT ARRANGEMENTS**

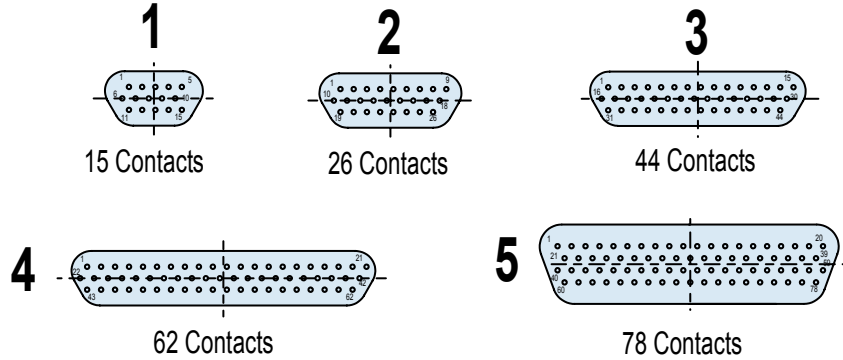

**TABLE I: CONNECTOR DIMENSIONS**

Shell Size	Dim A $\pm .015 (\pm 0.4)$	Dim B $\pm .004 (\pm 0.1)$	Dim C $\pm .005 (\pm 0.1)$	Dim D $\pm .004 (\pm 0.1)$	Dim E $\pm .010 (\pm 0.3)$	Dim F $\pm .010 (\pm 0.3)$	Dim G $\pm .010 (\pm 0.3)$	Dim H $\pm .010 (\pm 0.3)$	Dim K $\pm .006 (\pm 0.2)$	O-Ring 2-
1	1.213 (30.8)	.667 (16.9)	.984 (25.0)	.330 (8.4)	.600 (15.2)	.874 (22.2)	.272 (6.9)	.155 (3.9)	.235 (6.0)	-017
2	1.541 (39.1)	.993 (25.2)	1.312 (33.3)	.330 (8.4)	.600 (15.2)	1.270 (32.3)	.372 (9.5)	.155 (3.9)	.235 (6.0)	-022
3	2.088 (53.0)	1.535 (39.0)	1.852 (47.0)	.330 (8.4)	.600 (15.2)	1.760 (44.7)	.372 (9.5)	.160 (4.1)	.230 (5.8)	-027
4	2.729 (69.3)	2.183 (55.4)	2.500 (63.5)	.330 (8.4)	.600 (15.2)	2.418 (61.4)	.372 (9.5)	.160 (4.1)	.230 (5.8)	-031
5	2.635 (66.9)	2.079 (52.8)	2.406 (61.1)	.441 (11.2)	.610 (15.5)	2.418 (61.4)	.372 (9.5)	.160 (4.1)	.230 (5.8)	-031

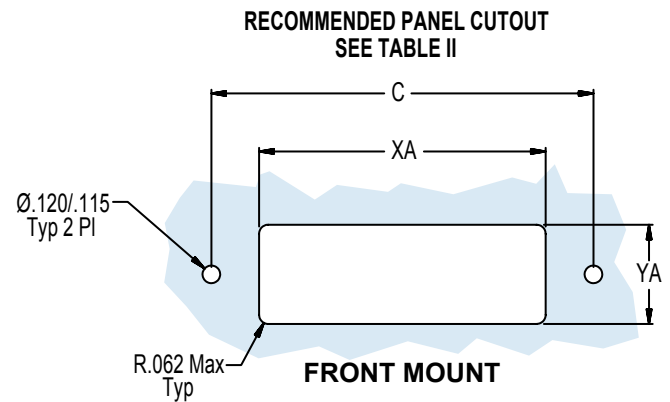
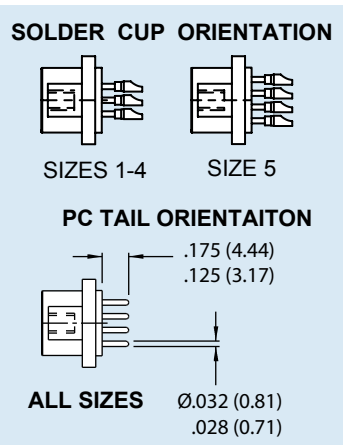

**TABLE II: PANEL CUT-OUT**

Shell Size	Dim XA	Dim YA	Dim C
1	.500 (12.7)	.220 (5.6)	.674 (17.1)
2	.830 (21.1)	.220 (5.6)	1.070 (27.2)
3	1.375 (34.9)	.220 (5.6)	1.560 (39.6)
4	2.000 (50.8)	.220 (5.6)	2.150 (54.6)
5	1.850 (47.0)	.300 (7.6)	2.200 (55.9)

Dimensions in Inches (millimeters) are subject to change without notice.

**280-014**  
**MIL-DTL-24308/9 Type Hermetic**  
**O-Ring Panel Sealing**  
**Glass-Sealed D-Subminiature Connector**



MIL-DTL-24308  
Type

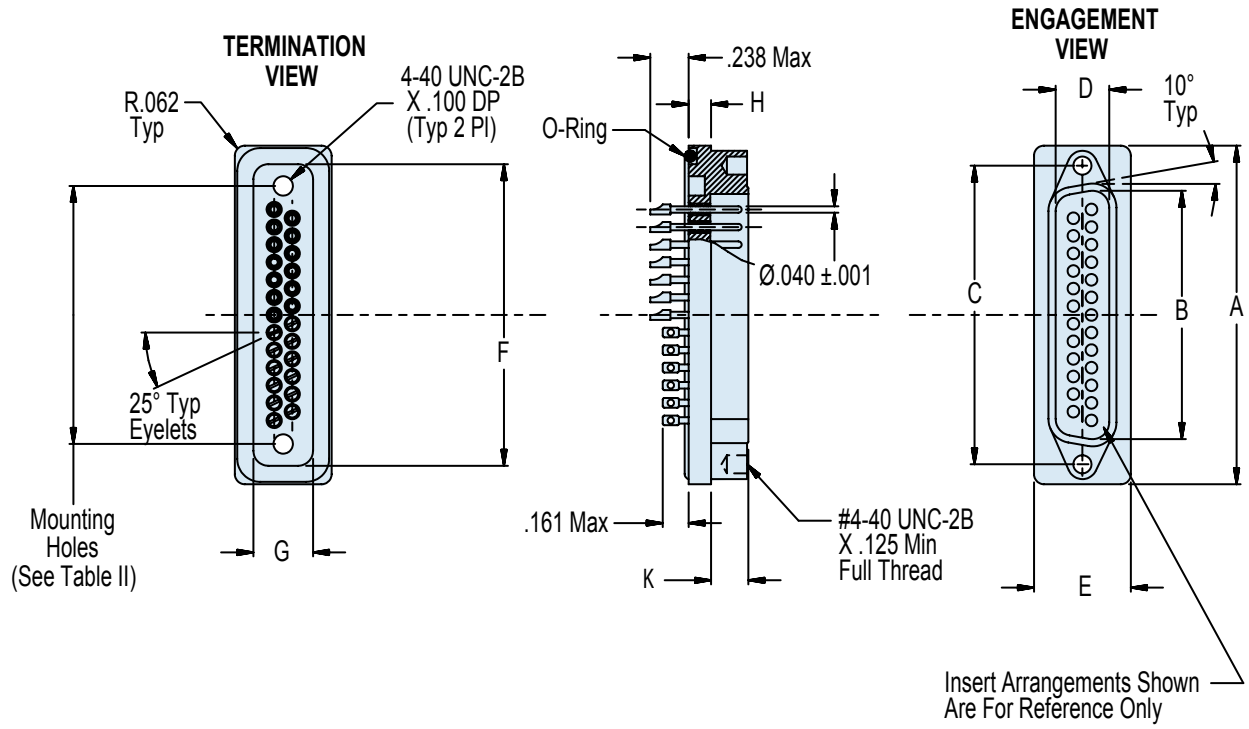
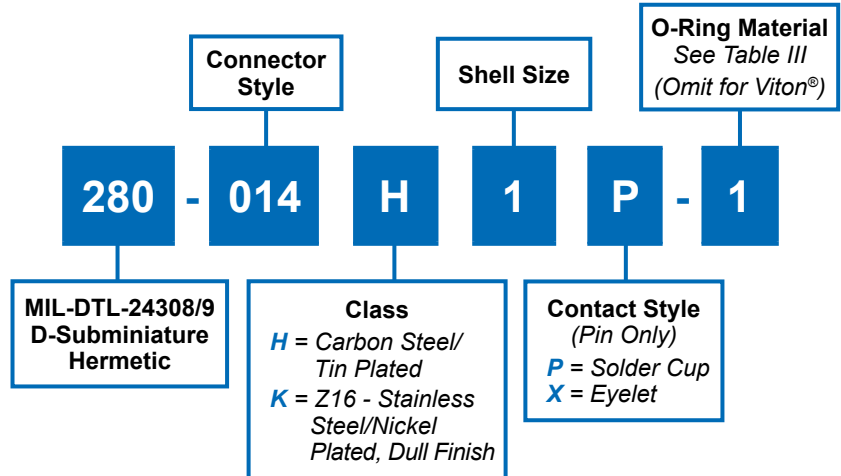

J

**APPLICATION NOTES**

- To be identified with manufacturer's name, part number and date code, space permitting.
- Contact Style: Eyelet or solder cup (see part development).
- Material/Finish:  
 Shell: H = FT - Carbon steel/tin plated.  
 K = Z16 - Stainless steel/nickel plated dull finish.  
 Insulators: Glass bead/N.A.  
 Contacts: Alloy 52/gold plated  
 O-Ring: Specify (see Table III)/N.A.
- Performance:  
 DWV - 500 VAC Pin-to-Shell  
 I.R. - 5,000 MegOhms Min @ 500 VDC  
 Hermeticity - <math>1 \times 10^{-7}</math> scc He/sec @1 atmosphere differential
- Glenair 280-014 will mate with any QPL MIL-DTL-24308/1, /2 and /23 receptacle of the same size and arrangement.
- Metric dimensions (mm) are indicated in parentheses.

Dimensions in Inches (millimeters) are subject to change without notice.



**280-014**  
**MIL-DTL-24308/9 Type Hermetic**  
**O-Ring Panel Sealing**  
**Glass-Sealed D-Subminiature Connector**

**TABLE III: O-RING MATERIAL**

Dash Number	Material
None	Viton®
-1	Nitrile
-2	Fluorosilicone
-3	Silicone

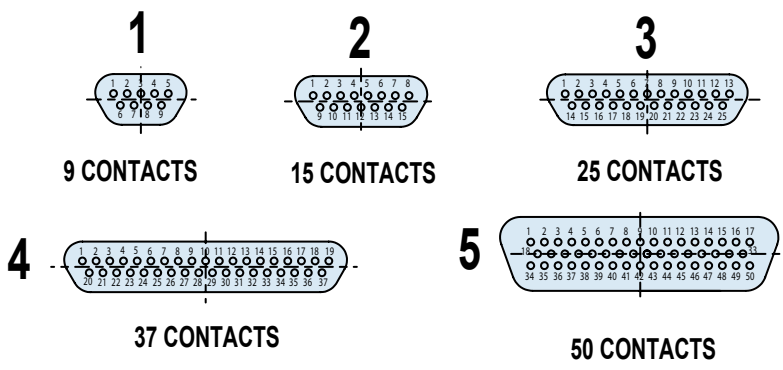
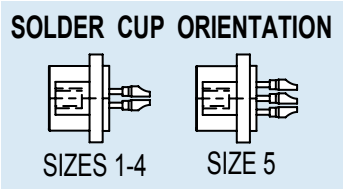

**TABLE I: CONNECTOR DIMENSIONS**

Shell Size	Dim A ± .015 (± 0.4)	Dim B ± .004 (± 0.1)	Dim C ± .005 (± 0.1)	Dim D ± .004 (± 0.1)	Dim E ± .010 (± 0.3)	Dim F ± .010 (± 0.3)	Dim G ± .010 (± 0.3)	Dim H ± .010 (± 0.3)	Dim K ± .006 (± 0.2)	O-Ring 2-
1	1.213 (30.8)	.667 (16.9)	.984 (25.0)	.330 (8.4)	.600 (15.2)	.874 (22.2)	.272 (6.9)	.155 (3.9)	.235 (6.0)	-017
2	1.541 (39.1)	.993 (25.2)	1.312 (33.3)	.330 (8.4)	.600 (15.2)	1.270 (32.3)	.372 (9.5)	.155 (3.9)	.235 (6.0)	-022
3	2.088 (53.0)	1.535 (39.0)	1.852 (47.0)	.330 (8.4)	.600 (15.2)	1.760 (44.7)	.372 (9.5)	.160 (4.1)	.230 (5.8)	-027
4	2.729 (69.3)	2.183 (55.4)	2.500 (63.5)	.330 (8.4)	.600 (15.2)	2.418 (61.4)	.372 (9.5)	.160 (4.1)	.230 (5.8)	-031
5	2.635 (66.9)	2.079 (52.8)	2.406 (61.1)	.441 (11.2)	.610 (15.5)	2.418 (61.4)	.372 (9.5)	.160 (4.1)	.230 (5.8)	-031

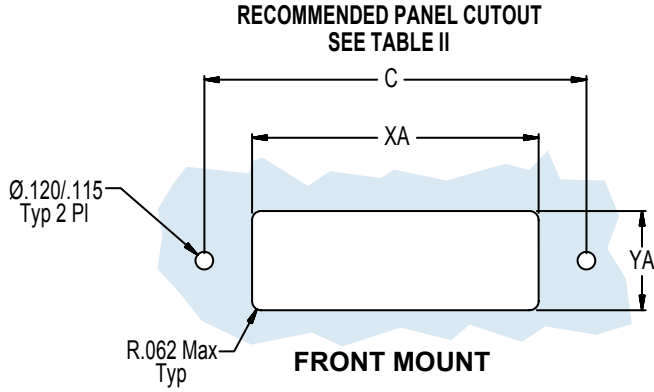

**TABLE II: PANEL CUT-OUT**

Shell Size	Dim XA	Dim YA	Dim C
1	.520 (13.2)	.220 (5.6)	.674 (17.1)
2	.850 (21.6)	.300 (7.6)	1.070 (27.2)
3	1.380 (35.1)	.300 (7.6)	1.560 (39.6)
4	2.035 (51.7)	.300 (7.6)	2.200 (55.9)
5	1.850 (47.0)	.320 (8.1)	2.200 (55.9)

Dimensions in Inches (millimeters) are subject to change without notice.

**287-018**  
**MIL-DTL-24308/9 Type Hermetic**  
**Glass-Sealed D-Subminiature Connector**  
**Front Mount O-Ring Seal**



MIL-DTL-24308  
Type

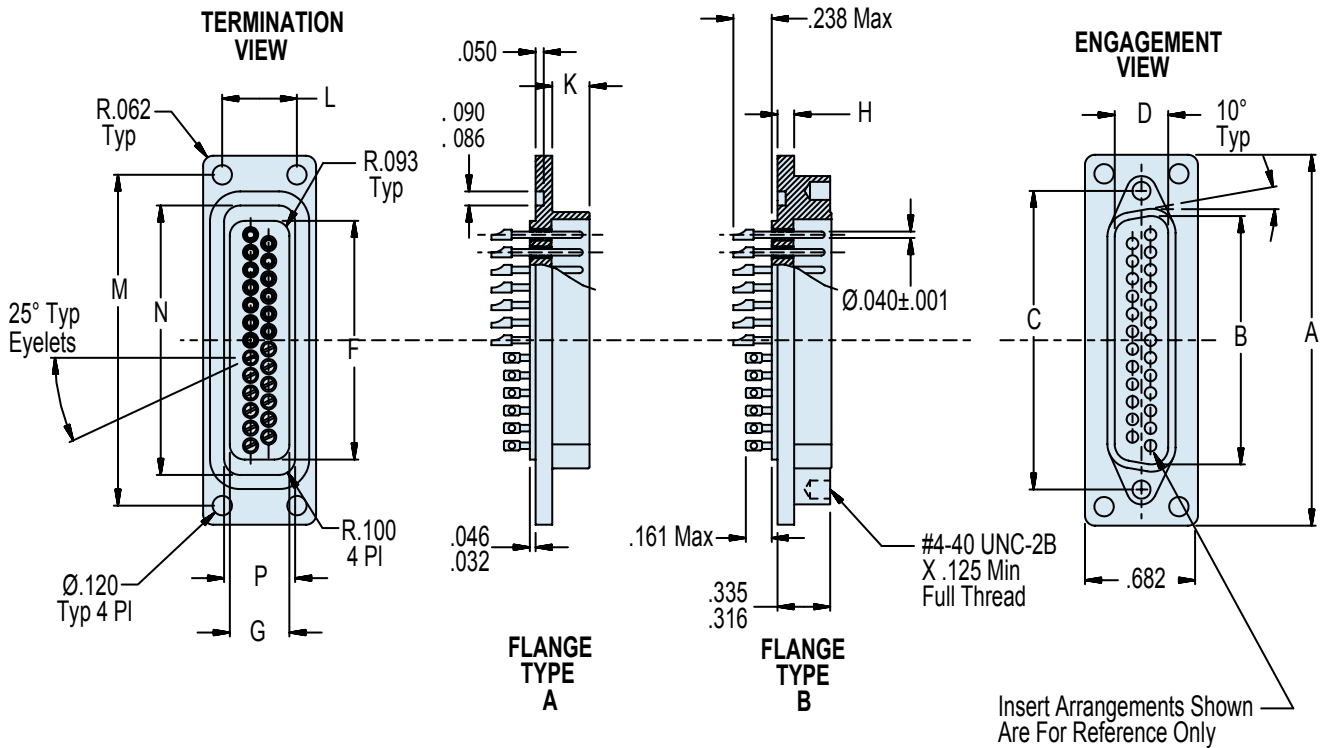
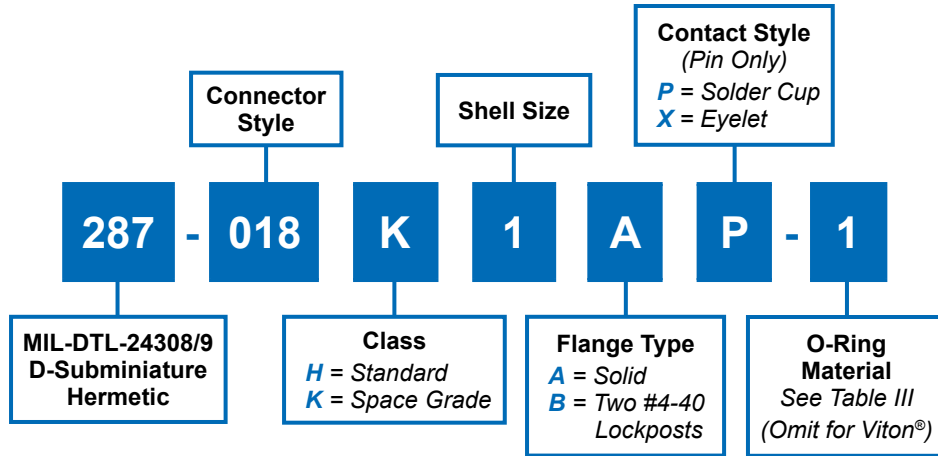

J

**APPLICATION NOTES**

- To be identified with manufacturer's name, part number and date code, space permitting.
- Contact Style: Eyelet or solder cup (see part development).
- Material/Finish:  
 Shell: H = FT - Carbon steel/tin plated.  
 K = Z16 - Stainless steel/nickel plated dull finish.  
 Insulators: Glass bead/N.A.  
 Contacts: Pins, alloy 52/gold plated.
- Metric dimensions (mm) are indicated in parentheses.
- Performance:  
 DWV - 750 VAC Pin-to-Shell  
 I.R. - 5,000 Megohms Min @ 500 VDC  
 Hermeticity -  $<1 \times 10^{-7}$  scc He/sec @ 1 atmosphere differential.
- All dimensions are typical for flange types "A" and "B". "C" dim is not applicable to flange type "A".
- Glenair 287-018 will mate with any QPL MIL-DTL-24308/1, /2 and /23 receptacle of the same size and arrangement.

Dimensions in Inches (millimeters) are subject to change without notice.



**287-018**  
**MIL-DTL-24308/9 Type Hermetic**  
**Glass-Sealed D-Subminiature Connector**  
**Front Mount O-Ring Seal**

**TABLE III: O-RING MATERIAL**

Dash Number	Material
None	Viton®
-1	Nitrile
-2	Fluorosilicone
-3	Silicone
CE*	Conductive Epdm
CF*	Conductive Fluorsilicone
CS*	Conductive Silicone

\*Customer to specify Chomerics® compound of choice.

**Example:**

CF1217 = Silver-Plated copper in fluorosilicone

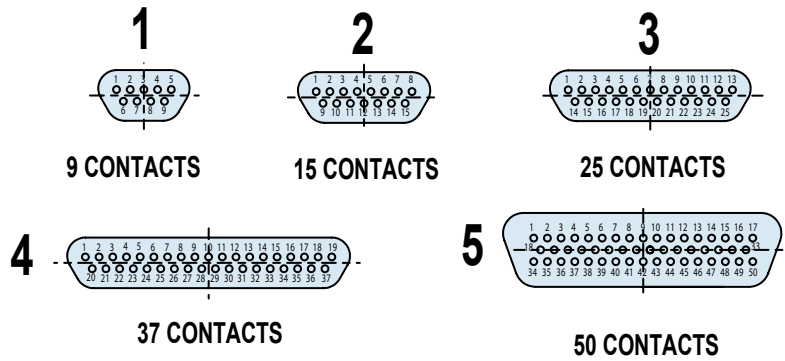

**TABLE I: CONNECTOR DIMENSIONS**

Shell Size	Dim A ± .015 (± 0.4)	Dim B ± .004 (± 0.1)	Dim C ± .005 (± 0.1)	Dim D ± .004 (± 0.1)	Dim E ± .010 (± 0.3)	Dim F ± .010 (± 0.3)	Dim G ± .010 (± 0.3)	Dim H ± .010 (± 0.3)	Dim K ± .006 (± 0.2)	Dim L BSC	M BSC	N ± .005 (± 0.1)	P ± .005 (± 0.1)
1	1.413 (35.9)	.667 (16.9)	.984 (25.0)	.330 (8.4)	.698 (17.7)	.725 (18.4)	.369 (9.4)	.094 (2.4)	.235 (6.0)	.462 (11.7)	1.177 (29.9)	.805 (20.4)	.440 (11.2)
2	1.741 (44.2)	.993 (25.2)	1.312 (33.3)	.330 (8.4)	.698 (17.7)	.932 (23.7)	.369 (9.4)	.094 (2.4)	.235 (6.0)	.462 (11.7)	1.499 (38.1)	1.002 (25.5)	.440 (11.2)
3	2.288 (58.1)	1.535 (39.0)	1.852 (47.0)	.330 (8.4)	.698 (17.7)	1.479 (37.6)	.369 (9.4)	.103 (2.6)	.230 (5.8)	.462 (11.7)	1.972 (50.1)	1.589 (40.4)	.440 (11.2)
4	2.929 (74.4)	2.183 (55.4)	2.500 (63.5)	.330 (8.4)	.698 (17.7)	2.125 (54.0)	.369 (9.4)	.103 (2.6)	.230 (5.8)	.462 (11.7)	2.693 (68.4)	2.183 (55.4)	.440 (11.2)
5	2.835 (72.0)	2.079 (52.8)	2.406 (61.1)	.441 (11.2)	.810 (20.6)	2.000 (50.8)	.500 (12.7)	.103 (2.6)	.230 (5.8)	.654 (16.6)	2.599 (66.0)	2.250 (57.2)	.570 (14.5)

**RECOMMENDED PANEL CUTOUT**  
SEE TABLE 2

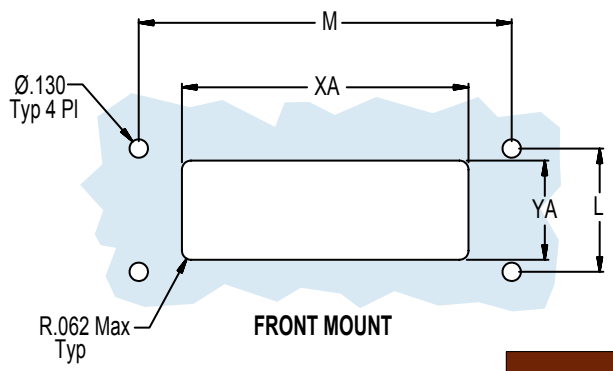

HERMETIC LEAK RATE MOD CODES	
Designator	Required Leak Rate
-585A	1 x 10 <sup>-10</sup> cc Helium per second
-585B	1 x 10 <sup>-9</sup> cc Helium per second
-585C	1 x 10 <sup>-8</sup> cc Helium per second

**SOLDER CUP ORIENTATION**

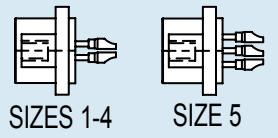

**TABLE II: PANEL CUT-OUT**

Shell Size	Dim XA	Dim YA	Dim L	Dim M
1	.745 (18.9)	.385 (9.8)	.462 (11.7)	1.177 (29.9)
2	.950 (24.1)	.385 (9.8)	.462 (11.7)	1.499 (38.1)
3	1.495 (38.0)	.385 (9.8)	.462 (11.7)	1.972 (50.1)
4	2.145 (54.5)	.385 (9.8)	.462 (11.7)	2.693 (68.4)
5	2.015 (51.2)	.520 (13.2)	.654 (16.6)	2.599 (66.0)

Dimensions in Inches (millimeters) are subject to change without notice.

**287-035**  
**MIL-DTL-24308/9 Type Hermetic High Density**  
**Glass-Sealed D-Subminiature Connector**



MIL-DTL-24308  
Type

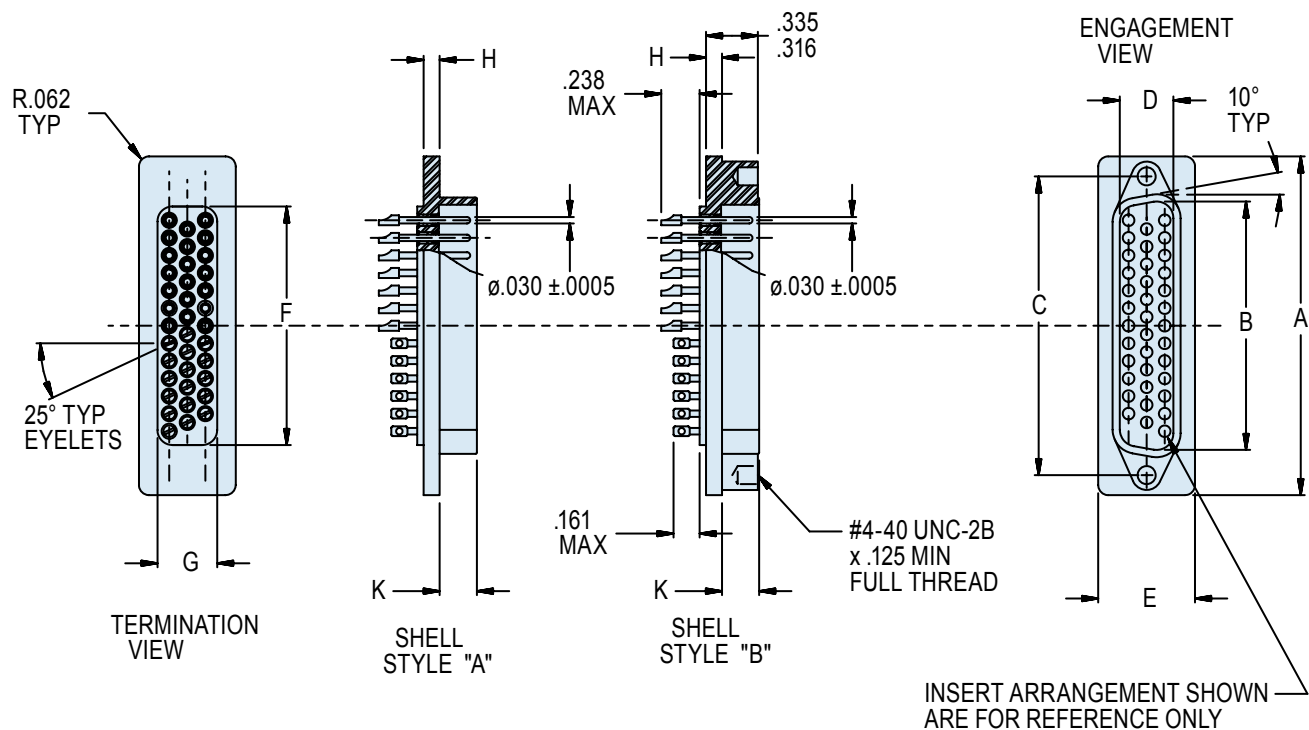
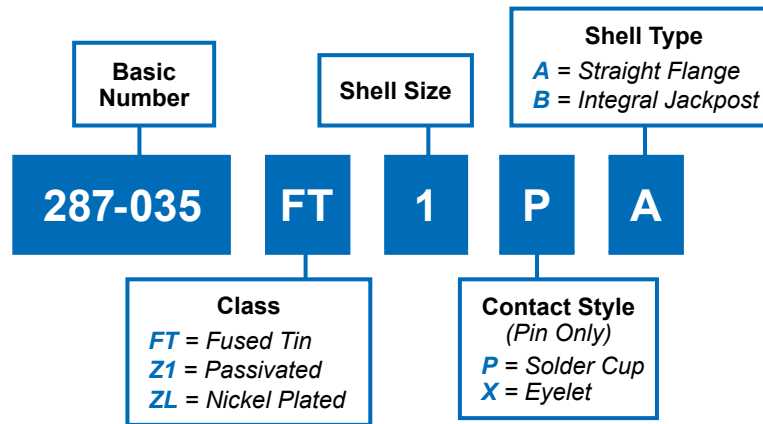

J

**APPLICATION NOTES**

- To be identified with manufacturer's name, part number and date code, space permitting.
- Contact Style: Eyelet or solder cup (see part development).
- Material/Finish:  
 Shell: FT = Carbon Steel / Fused Tin  
 Z1 = CRES / Passivated  
 ZL = CRES / Nickel Plated  
 Insulators: Glass bead/N.A.  
 Contacts: Nickel-Iron Alloy / Gold Plated
- Metric dimensions (mm) are indicated in parentheses.
- Performance:  
 DWV - 500 VAC Pin-to-Shell  
 I.R. - 5,000 Megohms Min @ 500 VDC  
 Hermeticity -  $<1 \times 10^{-5}$  scc He/sec @ 1 atmosphere differential.
- Glenair 287-035 will mate with any QPL MIL-DTL-24308/2, /6 and /23 receptacle of the same size and arrangement.

Dimensions in Inches (millimeters) are subject to change without notice.



**287-035**  
**MIL-DTL-24308/9 Type Hermetic High Density**  
**Glass-Sealed D-Subminiature Connector**

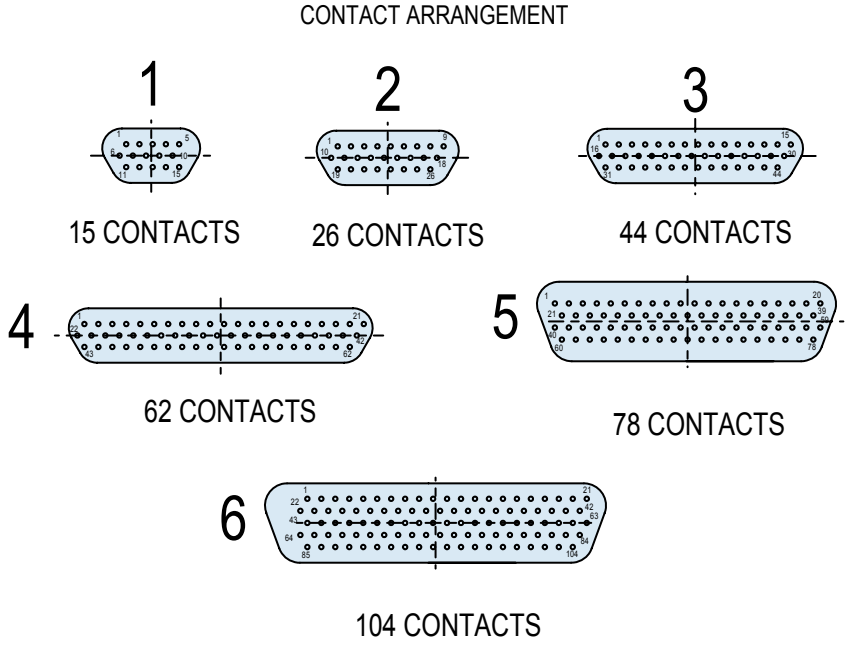
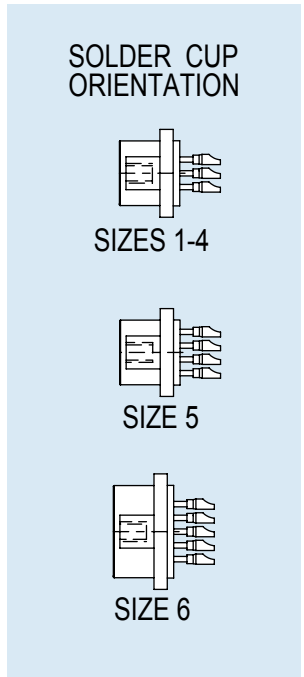

RECOMMENDED PANEL CUTOUT  
SEE TABLE II

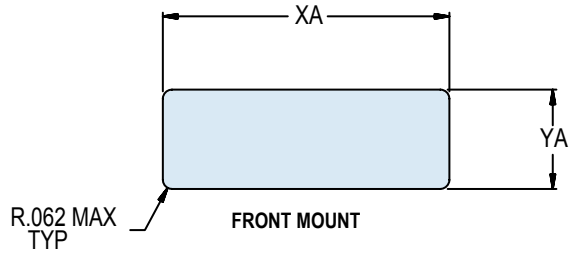

**TABLE I: CONNECTOR DIMENSIONS**

Shell Size	Dim A ± .015 (± 0.4)	Dim B ± .005 (± 0.1)	Dim C ± .005 (± 0.1)	Dim D ± .004 (± 0.1)	Dim E ± .010 (± 0.3)	Dim F ± .010 (± 0.3)	Dim G ± .005 (± 0.1)	Dim H ± .010 (± 0.3)	Dim K ± .006 (± 0.2)
1	1.213 (30.8)	.667 (16.9)	.984 (25.0)	.330 (8.4)	.498 (12.6)	.759 (19.3)	.422 (10.7)	.094 (2.4)	.235 (6.0)
2	1.541 (39.1)	.993 (25.2)	1.312 (33.3)	.330 (8.4)	.498 (12.6)	1.083 (27.5)	.422 (10.7)	.094 (2.4)	.235 (6.0)
3	2.088 (53.0)	1.535 (39.0)	1.852 (47.0)	.330 (8.4)	.498 (12.6)	1.625 (41.3)	.422 (10.7)	.103 (2.6)	.230 (5.8)
4	2.729 (69.3)	2.183 (55.4)	2.500 (63.5)	.330 (8.4)	.498 (12.6)	2.272 (57.7)	.422 (10.7)	.103 (2.6)	.230 (5.8)
5	2.635 (66.9)	2.079 (52.8)	2.406 (61.1)	.441 (11.2)	.610 (15.5)	2.178 (55.3)	.534 (13.6)	.103 (2.6)	.230 (5.8)
6	2.729 (69.3)	2.212 (56.2)	2.500 (63.5)	.503 (12.8)	.668 (17.0)	2.302 (58.5)	.596 (15.1)	.103 (2.6)	.230 (5.8)

**TABLE II: PANEL CUT-OUT**

Shell Size	Dim. XA	Dim. YA
	± .005 (.13)	
1	.775 (19.7)	.438 (11.1)
2	1.099 (27.9)	.438 (11.1)
3	1.642 (41.7)	.438 (11.1)
4	2.288 (58.1)	.438 (11.1)
5	2.194 (55.7)	.550 (14.0)
6	2.318 (58.9)	.612 (15.5)

Dimensions in Inches (millimeters) are subject to change without notice.



**287-159**  
**MIL-DTL-24308/9 Type Hermetic**  
**D-Subminiature Pin-to-Pin Feedthrough**



MIL-DTL-24308  
Type

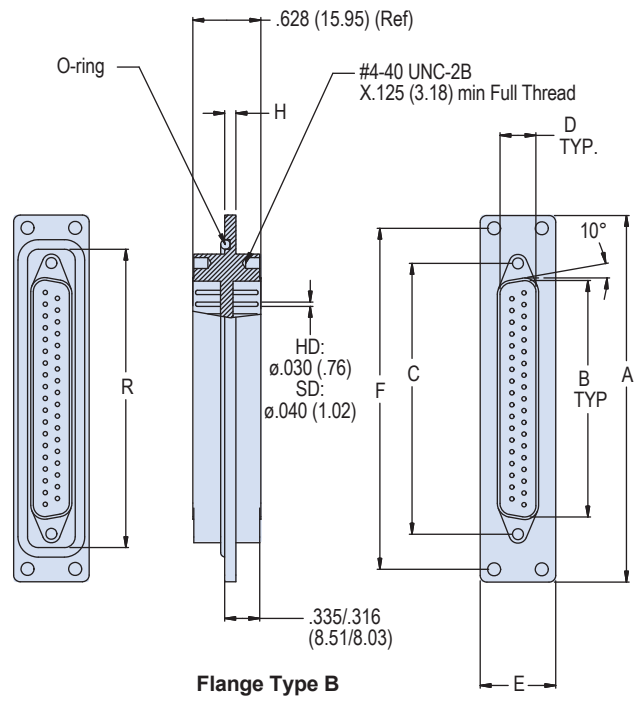
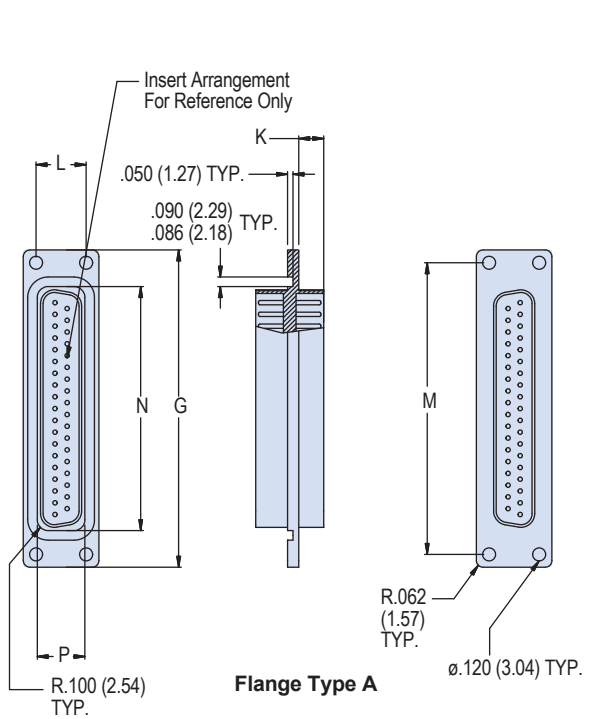
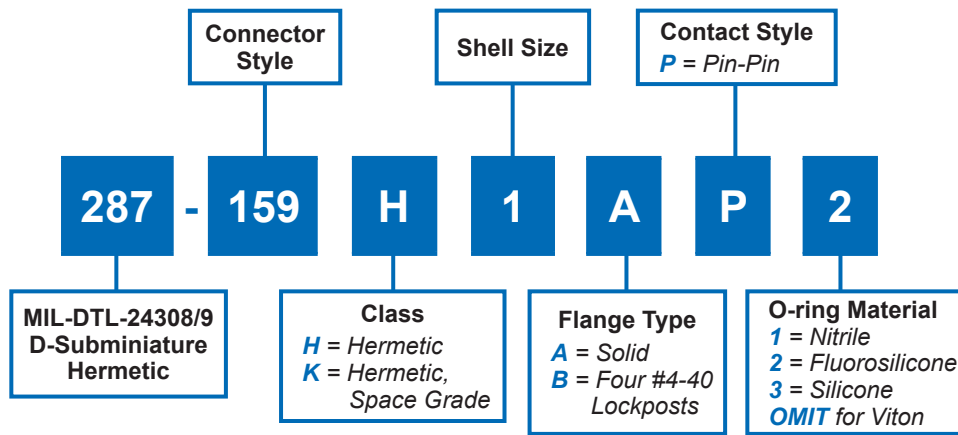

**J**

**APPLICATION NOTES**

- To be identified with manufacturer's name, part number and date code, space permitting.
- Contact Style: Pin-to-Pin only (See Part Number Development).
- All dimensions are typical for flange types "A" and "B." "C" dim is not applicable to flange type "A."
- Material/Finish:  
 Shell: H = FT - Carbon steel/tin plated.  
 K = Z16 - Stainless steel/nickel plated, Dull Finish
- Performance:  
 DWV - SD = 750 VAC Pin-to-Shell  
 - HD = 500 VAC Pin-to-Shell  
 I.R. - 5,000 MegOhms Min @ 500 VDC  
 Hermeticity -  $1 \times 10^{-5}$  ccHe/sec @1 atmosphere differential
- Glenair 287-159 will mate with any QPL MIL-DTL-24308/1, /2 and /23 receptacle of the same size and arrangement.
- Metric dimensions (mm) are indicated in parentheses.

Dimensions in Inches (millimeters) are subject to change without notice.



# 287-159 MIL-DTL-24308/9 Type Hermetic D-Subminiature Pin-to-Pin Feedthrough



STANDARD DENSITY CONTACT ARRANGEMENT

**TABLE I: CONNECTOR DIMENSIONS**

Shell Size	Dim A ± .015 (± 0.4)	Dim B ± .004 (± 0.1)	Dim C BSC	Dim D ± .004 (± 0.1)	Dim E ± .010 (± 0.3)	Dim F BSC	Dim G ± .010 (± 0.3)	Dim H ± .006 (± 0.2)	Dim K ± .010 (± 0.3)	L BSC	M BSC	N .005 (.127)	P	R	O-ring Req'd Type A	O-ring Req'd Type B
1	1.865 47.37	.667 16.94	.984 24.99	.330 8.38	.698 17.73	1.629 41.38	1.413 35.89	.094 2.39	.235 5.97	.462 11.73	1.177 29.90	.806 20.47	.440 11.18	1.238 31.45	2-108	2-022
2	2.200 55.88	.993 25.22	1.312 33.32	.330 8.38	.698 17.73	1.964 49.89	1.741 44.22	.094 2.39	.235 5.97	.462 11.73	1.499 38.07	1.100 27.94	.440 11.18	1.564 39.73	2-021	2-026
3	2.736 69.49	1.535 38.99	1.852 47.04	.330 8.38	.698 17.73	2.500 63.50	1.288 32.72	.103 2.62	.230 5.84	.462 11.73	2.052 52.12	1.690 42.93	.440 11.18	2.106 53.49	2-027	2-030
4	3.385 85.98	2.183 55.45	2.500 63.50	.330 8.38	.698 17.73	3.149 79.98	2.929 74.40	.103 2.62	.230 5.84	.462 11.73	2.693 68.40	2.291 58.19	.440 11.18	2.755 69.98	2-031	2-033
5	3.289 83.54	2.079 52.81	2.406 61.11	.441 11.20	.810 20.57	3.053 77.55	2.835 72.01	.103 2.62	.230 5.84	.574 14.58	2.599 66.01	2.186 55.52	.570 14.48	2.650 67.31	2-030	2-033

J

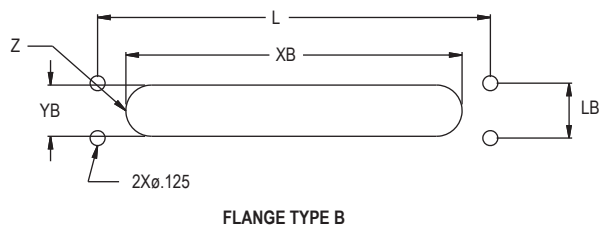
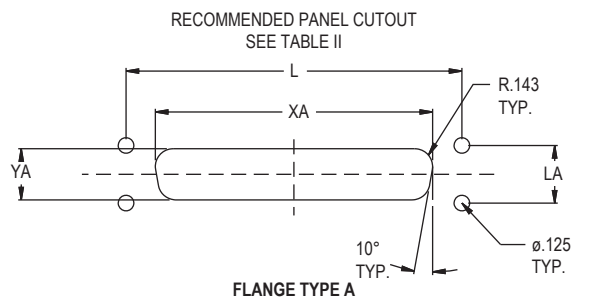

**TABLE II: PANEL CUT-OUT DIMENSIONS - STYLE A**

Shell Sizes	Dim XA	Dim YA	Dim LA	Dim L
1	.744 (18.90)	.410 (10.41)	.462 (11.73)	1.177 (29.90)
2	1.070 (27.18)	.410 (10.41)	.462 (11.73)	1.499 (38.07)
3	1.612 (40.94)	.410 (10.41)	.462 (11.73)	2.052 (52.12)
4	2.261 (57.43)	.410 (10.41)	.462 (11.73)	2.693 (68.40)
5	2.156 (54.76)	.520 (13.21)	.574 (14.58)	2.599 (66.01)

**TABLE II: PANEL CUT-OUT DIMENSIONS - STYLE B**

Shell Sizes	Dim XB	Dim YB	Rad. Z	Dim L	Dim LB
1	1.180 (29.97)	.410 (10.41)	.205 (5.21)	1.629 (41.38)	.462 (11.73)
2	1.508 (38.30)	.410 (10.41)	.205 (5.21)	1.964 (49.89)	.462 (11.73)
3	2.048 (52.02)	.410 (10.41)	.205 (5.21)	2.500 (63.50)	.462 (11.73)
4	2.696 (68.48)	.410 (10.41)	.205 (5.21)	3.149 (79.98)	.462 (11.73)
5	2.602 (66.09)	.520 (13.21)	.260 (6.60)	3.053 (77.55)	.574 (14.58)

Dimensions in Inches (millimeters) are subject to change without notice.

**287-450**  
**MIL-DTL-24308/9 Type**  
**Glass Sealed Rear Panel Mount D-Subminiature with O-Ring**



MIL-DTL-24308  
Type

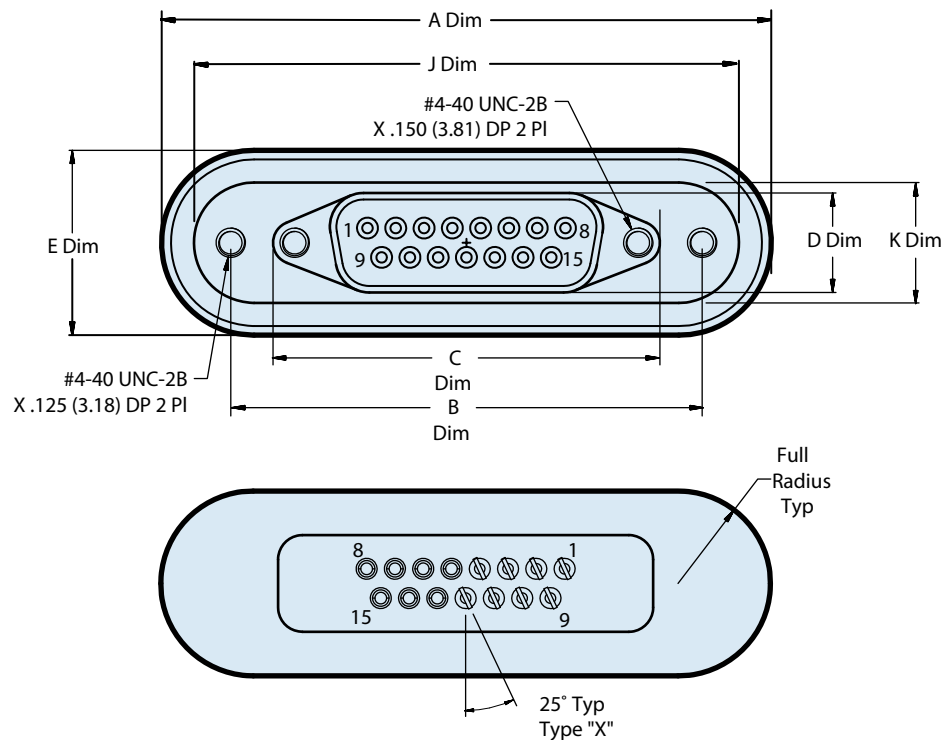
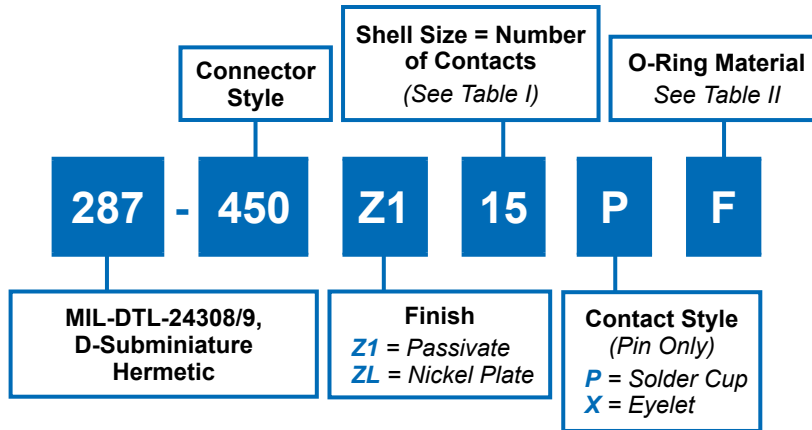

J

**APPLICATION NOTES**

- |   |  |
|---|--|
| <p>1. <b>Material/Finish:</b><br/>         Shell: CRES/Passivate or CRES/Nickel Plated.<br/>         Insulators: Glass bead/N.A.<br/>         Contacts: Nickel-iron alloy/Gold plated.<br/>         O-Ring: Specify.</p> <p>2. <b>Performance:</b><br/>         DWV - 750 VAC Pin-to-Shell (SD)<br/>         - 500 VAC Pin-to-Shell (HD)<br/>         I.R. - 5 Gigohms min @ 500 VDC<br/>         Hermeticity - &lt;math&gt;1 \times 10^{-7}&lt;/math&gt; scc He/sec @ 1 ATM Delta.</p> | <p>3. Glenair 287-450 series plug will mate with any QPL manufactured MIL-DTL-24308/1, /2 and /23 receptacle of the same size and contact arrangement with opposite contact gender.</p> <p>4. Part to be marked with Glenair part number, name and/or cage code and date code.</p> |
|---|--|

Dimensions in Inches (millimeters) are subject to change without notice.



**287-450**  
**MIL-DTL-24308/9 Type**  
**Glass Sealed D-Subminiatures Rear Panel Mount with O-Ring**

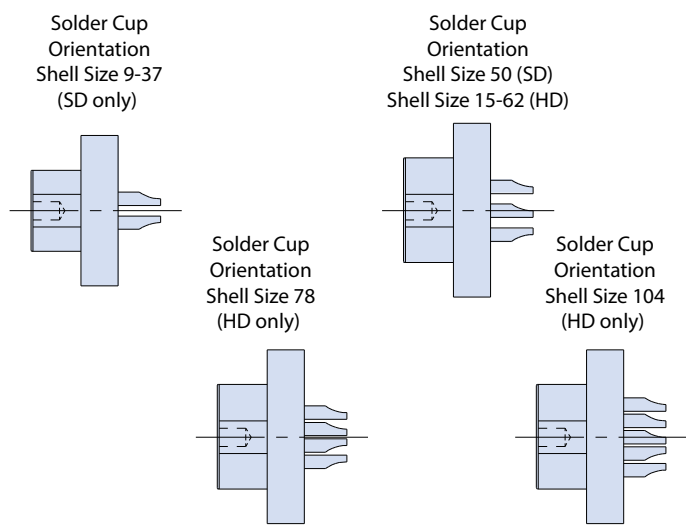

**J**

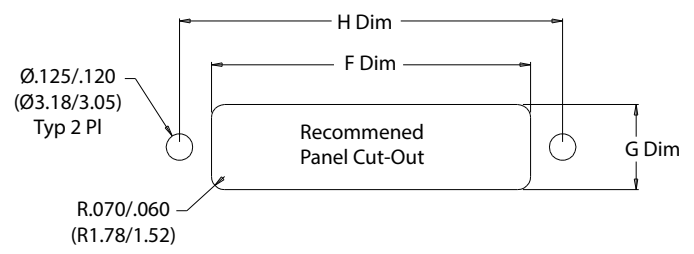

**TABLE I: DIMENSIONS**

Shell Size		A Dim		B Dim		C Dim		D Dim		E Dim		F Dim		G Dim		H Dim		O-Ring	J Dim		K Dim	
SD	HD	In.	mm.	In.	mm.	In.	mm.	In.	mm.	In.	mm.	In.	mm.	In.	mm.	In.	mm.		In.	mm.	In.	mm.
<b>9</b>	<b>15HD</b>	1.922	48.82	1.484	37.69	1.150	29.21	.380	9.65	.710	18.03	1.175	29.85	.400	10.16	1.484	37.69	2-026	1.676	42.57	.464	11.79
<b>15</b>	<b>26HD</b>	2.33	59.18	1.800	45.72	1.477	37.52	.380	9.65	.710	18.03	1.500	38.10	.400	10.16	1.800	45.72	2-029	2.084	52.93	.464	11.79
<b>25</b>	<b>44HD</b>	2.715	68.96	2.277	57.84	2.017	51.23	.380	9.65	.710	18.03	2.040	51.82	.400	10.16	2.277	57.84	2-031	2.469	62.71	.464	11.79
<b>37</b>	<b>62HD</b>	3.500	88.90	3.000	76.20	2.665	67.69	.380	9.65	.710	18.03	2.690	68.33	.400	10.16	3.000	76.20	2-035	3.254	82.65	.464	11.79
<b>50</b>	<b>78HD</b>	3.440	87.38	2.950	74.93	2.570	65.28	.491	12.47	.820	20.83	2.590	65.79	.510	12.95	2.950	74.93	2-035	3.194	81.13	.574	14.58
<b>NA</b>	<b>104HD</b>	3.385	85.98	3.000	76.20	2.665	67.69	.55	13.97	.885	22.48	2.685	68.20	.570	14.48	3.000	76.20	2-035	3.151	80.04	.643	16.33

**TABLE II: O-RING MATERIAL**

Symbol	Material
<b>E</b>	EPDM
<b>F</b>	Fluorosilicone
<b>N</b>	Nitrile
<b>V</b>	Viton®

Dimensions in Inches (millimeters) are subject to change without notice.

GLASS-TO-METAL  
SEAL

# MIL-DTL-83513 TYPE

## *Micro-D Hermetic Connectors*



Glenair MIL-DTL-83513 type Micro-D hermetic connectors are ideal for high-pressure/low-leakage applications where size, weight and vibration resistance are a critical concern. Sophisticated electronics enclosures, vacuum chambers and cryogenic equipment all benefit from the airtight seal and moisture resistant plating found on Glenair hermetic Micro-D connectors. Solder mount, weld mount and rear panel O-ring shell styles are available to meet a variety of design requirements. Kovar®—an iron nickel alloy—is used in both the shells and contacts, and provides a chemical bond with the glass insulator for maximum hermeticity. Shells are then plated with nickel after the glass insulator is fired to enhance corrosion resistance. Contacts are plated with gold to ensure superior electrical conductivity.

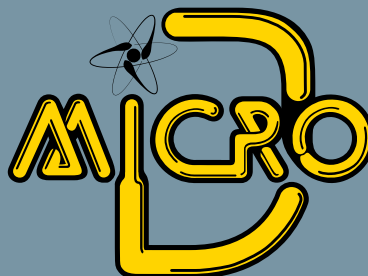

**G**lenair®

Glenair, Inc.  
1211 Air Way  
Glendale, CA  
91201-2497  
818-247-6000  
sales@glenair.com  
www.glenair.com

# MIL-DTL-83513 Type Micro-D Hermetic Connectors



## A Full Range of MIL-DTL-83513 Type Micro-D Hermetic Connectors

**Glenair Micro-D Hermetic Connectors** are offered with a minimum of 9 sockets, up to a maximum of 100 sockets—in two, three and four row solder cup and pigtail configurations. Fluorosilicone rubber interfacial seals and

O-rings ensure positive sealing with plug connectors and panels. Gold plated Kovar® socket contacts boast superior vibration resistance when used in conjunction with Glenair's innovative TwistPin contact system in the plug.

Quick Selection Guide		
Part Number	Description	Page
	MIL-DTL-83513 Type Micro-D Hermetic Connector Introduction	K-2
	Glenair Hermetic Connector Products Space Grade Mod Code	K-3
	MIL-DTL-83513 Type Micro-D Connectors General Information	K-4
	MIL-DTL-83513 Type Micro-D Design Notes and Contact Arrangements	K-5
	MIL-DTL-83513 Type Micro-D PCB Footprints	K-6
	MIL-DTL-83513 Type Micro-D Materials and Finishes and Performance Specifications	K-7
<b>177-140H and 177-704H</b>	Solder Mount Micro-D Hermetic Connector	K-8
<b>177-705H and 177-706H</b>	Rear Panel Mount with O-Ring Micro-D Hermetic Connector	K-10
<b>177-232</b>	Front Mount Socket Shell Micro-D Hermetic Connector, Size 37	K-13
<b>177-859</b>	Front Mount Socket Shell Micro-D Hermetic Connector, Sizes 9 to 21	K-14



## MIL-DTL-83513 Type Micro-D Hermetic Connectors Introduction

# A Full Range of MIL-DTL-83513 Type Micro-D Hermetic Connectors

### Product Applications

Glenair MIL-DTL-83513 type Micro-D hermetic connectors are ideal for high-pressure/low-leakage applications where size, weight and vibration resistance are a critical concern. Sophisticated electronics enclosures, vacuum chambers and cryogenic equipment all benefit from the airtight seal and moisture resistant plating found on Glenair hermetic Micro-D connectors. Solder mount, weld mount and rear panel O-ring shell styles are available to meet a variety of design requirements.

seals and O-rings ensure positive sealing with plug connectors and panels.

Gold plated Kovar® socket contacts boast superior vibration resistance when used in conjunction with Glenair's innovative TwistPin contact system in the plug.

### Same-Day Inventory

Because Glenair makes all its hermetic connectors in-house, including the machining of shells, molding of interfacial seals and firing

*Weld Mount, Solder Mount and Rear Panel Sealing Options*

*Vibration and Shock Resistant TwistPin Contact System*

*9 to 100 Sockets in 9 Shell Sizes*

*Space Grade Special Screening Available*

*1 x 10<sup>-6</sup> cc/Helium per Second Leakage Rate*

*Solder Cup, PC Tail and Pre-Wired Pigtail Termination Options*

*Machined Kovar® Shells and Contacts with Moisture Resistant Plating*

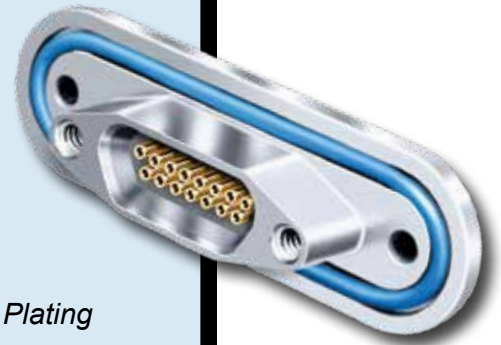

### Materials

Kovar®—an iron nickel alloy—is used in both the shells and contacts, and provides a chemical bond with the glass insulator for maximum hermeticity. Shells are then plated with nickel after the glass insulator is fired to enhance corrosion resistance. Contacts are plated with gold to ensure superior electrical conductivity.

Connectors are offered with a minimum of 9 sockets, up to a maximum of 100 sockets—in two, three and four row solder cup and pigtail configurations. Fluorosilicone rubber interfacial

of hermetic components, we can offer you outstanding availability on stock products and fast turnaround on special orders.

*Catalog contents—including part numbers, materials and dimensions—are accurate to the best of our ability when we go to print. Even so, customers are advised to consult the factory for the latest specifications, particularly to confirm critical dimensions such as connector lengths, threads, and so on. Corrected content is posted immediately to [www.glenair.com](http://www.glenair.com).*

Dimensions in Inches (millimeters) are subject to change without notice.

© 2013 Glenair, Inc.

U.S. CAGE Code 06324

Printed in U.S.A.

**GLENAIR, INC. • 1211 AIR WAY • GLENDALE, CA 91201-2497 • 818-247-6000 • FAX 818-500-9912**  
**www.glenair.com K-2 E-Mail: [sales@glenair.com](mailto:sales@glenair.com)**





### What is outgassing?

Plastic and rubber materials give off gaseous molecules. For example, the smell inside a new car is caused by polymer outgassing. Heat and vacuum increase the rate of diffusion. In a spacecraft the gases coming off polymers can contaminate optical surfaces and instruments. The result is degraded performance.

### How is outgassing measured?

The space industry has adopted a standardized test procedure, **ASTM E 595**, to evaluate out-gassing properties of polymers. Small samples of material are heated to 125° C. at a vacuum of  $5 \times 10^{-5}$  torr for 24 hours. Then the sample is weighed to calculate the **Total Mass Loss** (TML). The TML cannot exceed 1.00% of the total initial mass. During the test, outgassed matter condenses on a cooled collector plate. The quantity of outgassed matter is calculated to determine the **Collected Volatile Condensable Material** (CVCM). The CVCM cannot exceed 0.10% of the original specimen mass.

### What is NASA screening?

NASA specification EEE-INST-002 provides instructions on selecting, screening and qualifying parts for use on NASA GSFC space flight projects.

### What screening level is required?

NASA defines three levels of screening: level 1 for highest reliability, level 2 for high reliability, and level 3 for standard reliability. Level 3 equates to standard lot acceptance inspection. Levels 1 and 2 call for additional testing.

## HOW TO ORDER SPACE GRADE CONNECTORS

### Step 1: Find a Standard Part Number

Electroless nickel plated shells are preferred for space flight. Cadmium plating is prohibited.

### Step 2: Select a NASA Screening Level

The term "Screening Level" refers to the final inspection procedure.

**Level 1** for mission-critical highest reliability

**Level 2** for high reliability

**Level 3** for standard reliability

### Step 3: Choose Outgassing Processing

A detailed explanation of outgassing is on the following pages. The fluorosilicone rubber seals commonly used on aerospace-grade connectors such as MIL-DTL-38999 and Series 79 connectors, along with certain bonding agents and inks, do not meet NASA outgassing requirements unless the connector is specially processed. Glenair outgassing tests have shown oven baking or thermal vacuum outgassing processing are sufficient to reduce outgassing levels to NASA standards. Oven baking is more economical than thermal vacuum outgassing.

### Step 4: Select the Mod 429 Code that Matches the Desired Level of Screening and Outgassing

Use the following table to choose the right modification code. Add the mod code to the connector part number. Example: 790-024PC-13ML-**429C**

## NASA SCREENING LEVELS AND MODIFICATION CODES

NASA Screening Level	Special Screening Only	Special Screening Plus Outgassing Processing	
		8 Hour Oven Bake 400° F.	Thermal Vacuum Outgassing 24 hrs. 125° C.
Level 1 Highest Reliability	Mod 429B	Mod 429J	Mod 429C
Level 2 High Reliability	Mod 429	Mod 429K	Mod 429A
Level 3 Standard Reliability	(Use standard part number)	Mod 186	Mod 186M

Dimensions in Inches (millimeters) are subject to change without notice.



## MIL-DTL-83513 Type Micro-D Hermetic Connectors General Information

### MICRO-D HERMETIC CONNECTORS

Hermeticity is defined as "the state or condition of being airtight". Sophisticated military electronics enclosures can experience electrical failure from ingress of moisture. System engineers can design the enclosure to withstand exposure to moisture and condensation by using "moisture-hardened" components and conformal coatings, but often the most practical approach is to install hermetically sealed electrical I/O connectors. Glass-to-metal seals provide assurance that, over the life of the enclosure, the accumulated amount of water vapor inside the box will not exceed the amount necessary to form condensation. Other applications for Micro-D hermetic connectors include vacuum chambers, cryogenics, and enclosures filled with inert gas.

#### Kovar® Alloy

Glenair's hermetic Micro-D shells and contacts are made from a special alloy called Kovar®, an iron-nickel-cobalt alloy consisting of 54% Fe, 29% Ni, and 17% Co. This alloy is covered by SAE specification AMS-I-23011. Kovar has a relatively low coefficient of thermal expansion.

#### Micro-D Hermetic Plating Options

Unlike regular connectors which are plated as components prior to assembly, hermetic connectors are electroplated after the parts are fired and cleaned of oxides. Typically the contacts are gold-plated and the connector shell is nickel-plated.

#### Matched Glass-To-Metal Seals

Matched seals rely on a chemical bond between the metal and the glass. Kovar® contacts and shells are first exposed to high temperatures in order to develop an oxide coating. Then, the borosilicate glass and metal components are assembled with fixtures and are fused in a firing furnace at 900° C. A strong chemical bond is created between the metal and glass. Unlike compression seals which rely on different thermal coefficients of expansion between the glass and metal, a matched seal offers better resistance to stress from thermal extremes.

#### Connector Installation

Hermetic connectors are typically soldered or welded into panels or bulkheads. Laser welding is a good option if the connector is mounted onto Kovar®. If the panel is aluminum alloy or stainless steel, then soldering is recommended. Micro-D's with o-ring seals offer another alternative. O-rings, when installed properly, will provide a very low permeability seal. The seating surface must be free from scratches or imperfections. A 32 finish is acceptable, but a 16 finish is preferred. The o-ring can be coated with a light coat of vacuum grease.

#### Hermetic Testing

All Micro-D hermetic connectors are 100% tested prior to shipment. A helium leak test is performed to certify the hermetic seal. This test is conducted by inducing a 1 ATM vacuum on one side of the connector. Helium gas is released on the other side, and a mass spectrometer "counts" the number of helium molecules that penetrate the connector seal. Helium leak testing takes advantage of the small size of a helium molecule compared to air or water vapor. Helium is inert, rare in our atmosphere, and is easy to detect with a mass spectrometer.



Dimensions in Inches (millimeters) are subject to change without notice.

# MIL-DTL-83513 Type Micro-D Hermetic Connectors Design Notes and Contact Arrangements



## MICRO-D HERMETIC CONNECTOR DESIGN NOTES

### “Why can’t I get a hermetic Micro-D with pin contacts instead of sockets?”

The Micro-D TwistPin contact cannot be made from the materials that are required for hermetic contacts. Hermetic contacts are made from ferrous alloys such as Kovar® or Alloy 52. These alloys do not have spring properties. The Micro-D TwistPin contact is made from spring-temper beryllium copper. The Micro-D socket contact is a cylinder and does not provide any spring force, so Micro-D hermetic connectors are always receptacle connectors with socket contacts.

### “What about high pressure?” “What is the maximum recommended pressure rating for a hermetic Micro-D?”

Glenair hermetic Micro-D's are built to safely withstand 1000 PSI of hydrostatic pressure in an open face (unmated) condition.

## MICRO-D CONTACT ARRANGEMENTS (FACE VIEW SOCKET CONNECTOR)

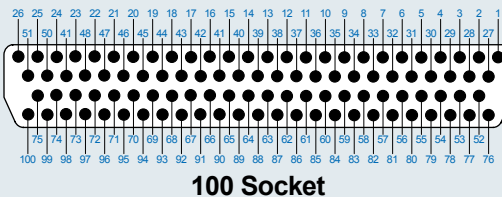
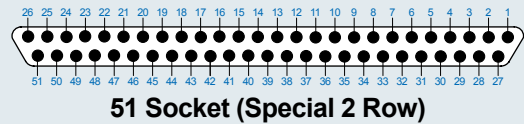
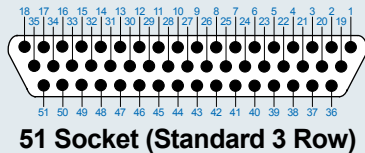
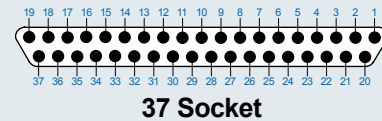
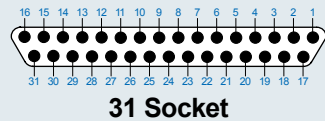
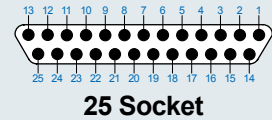
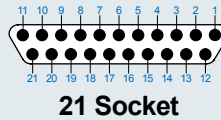
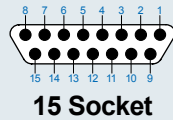
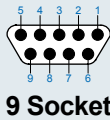

K

Dimensions in Inches (millimeters) are subject to change without notice.



MIL-DTL-83513 Type  
Micro-D Hermetic Connectors  
PCB Footprints for PC Tail Connectors

MICRO-D CONTACT ARRANGEMENTS (FACE VIEW SOCKET CONNECTOR)

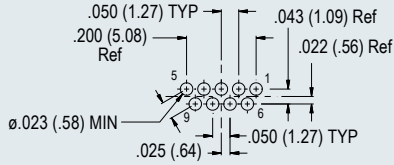

9 Socket

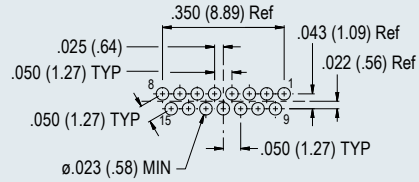

15 Socket

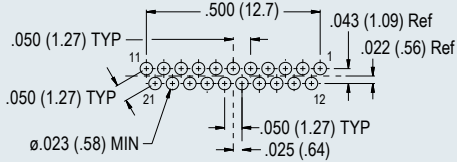

21 Socket

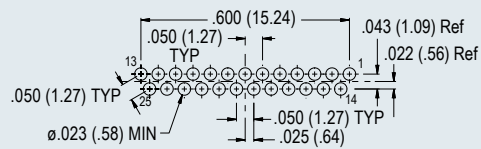

25 Socket

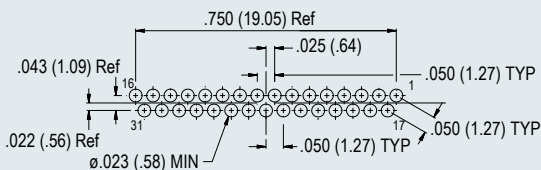

31 Socket

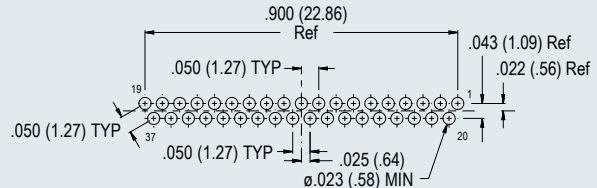

37 Socket

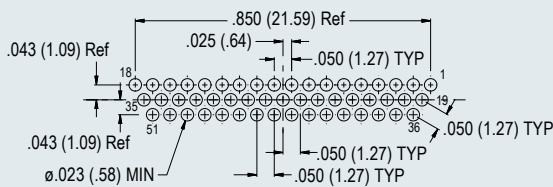

51 Socket (Standard 3 Row)

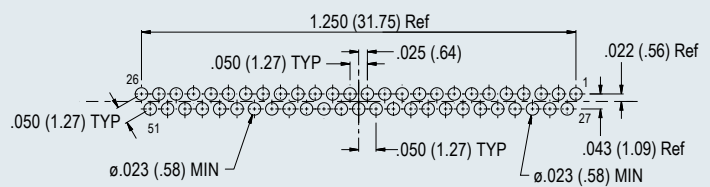

51 Socket (Special 2 Row)

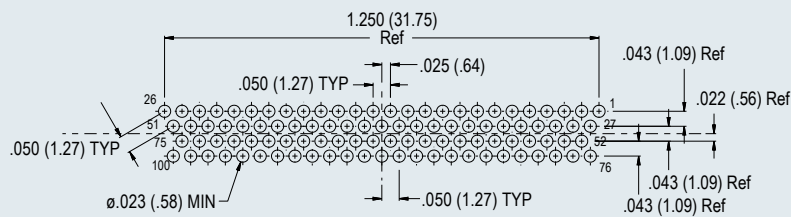

100 Socket

K

Dimensions in Inches (millimeters) are subject to change without notice.

**MIL-DTL-83513 Type  
Micro-D Hermetic Connectors  
Materials/Finishes and Performance Specifications**



**MATERIALS AND FINISHES**

Connector Shell	Kovar® Alloy in Accordance With SAE AMS-I-23011 Class 1, Plated with Electrodeposited Nickel In Accordance With SAE-AMS-QQ-N-290 Class 2, 0.0002-0.0003 Inches Thick.
Insulator	Borosilicate Glass
Interfacial Seal	Flourosilicone Rubber, Blue
Socket Contact	Kovar® Alloy in Accordance With SAE AMS-I-23011 Class 1, Gold Plated In Accordance With ASTM B 488 Type II, Class 1.27 (50 microinches minimum) over Nickel Underplate in Accordance With SAE-AMS-QQ-N-290 Class 2.
O-Ring	Flourosilicone Rubber, Blue
Encapsulant	Epoxy

**PERFORMANCE SPECIFICATIONS**

Current Rating	1.5 AMP
Dielectric Withstanding Voltage	150 VAC
Working Voltage	100 VDC
Insulation Resistance	5000 Megohms Minimum
Contact Resistance	40-50 Milliohms Maximum
Hermeticity	1 x 10 <sup>-7</sup> Maximum Helium Leak Rate per Second at One Atmosphere
Operating Temperature	-55° C. to +125° C.
Shock	50 g.
Vibration	20 g.
Outgassing	Meets NASA Outgassing Requirements (MOD Code 429)
Mating Force	(10 Ounces) X (# of Contacts)
For additional performance requirements, please refer to MIL-DTL-83513	

**HERMETIC LEAK RATE MOD CODES**

Designator	Required Leak Rate
585A	1 x 10 <sup>-10</sup> cc Helium per second
585B	1 x 10 <sup>-9</sup> cc Helium per second
585C	1 x 10 <sup>-8</sup> cc Helium per second

Dimensions in Inches (millimeters) are subject to change without notice.



## 177-140H and 177-704H MIL-DTL-83513 Type Micro-D Hermetic Connectors Solder Mount

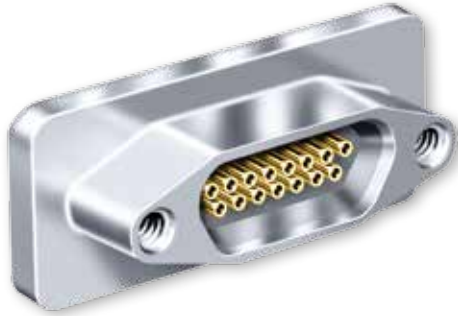

**Solder** these 177-140 hermetic Micro-D connectors. Featuring a matched glass-to-metal seal, these socket receptacles are designed for panel mounting.

**Kovar® Shells and Contacts** comply with applicable MIL-DTL-83513 requirements and are 100% intermateable with standard connectors.

**Choose 9 to 100 Contacts**, with gold-plated contacts and nickel-plated shells. These connectors feature integral female jackposts.

### HOW TO ORDER SOLDER CUP AND PC TAIL CONNECTORS

Series	Layout Number of Contacts	Contact Type	Termination Type
<b>177-140H</b> Micro-D Hermetic Socket Receptacle, Solder or Weld Mounting	9 15 21 25 31 37 51-2 51 100	<b>S</b> – Socket	<b>S</b> – Solder Cup <b>P</b> – PC Tail
<i>Sample Part Number</i>			
<b>177-140H</b>	<b>15</b>	<b>S</b>	<b>P</b>

### HOW TO ORDER PRE-WIRED CONNECTORS

Series	Layout	Contact Type	Wire Gage (AWG)	Wire Type	Wire Color	Wire Length Inches
<b>177-704H</b>	9 15 21 25 31 37 51-2 51 100	<b>S</b> – Socket	6 – #26 8 – #28 0 – #30	<b>K</b> – M22759/11 600 Vrms Teflon® (TFE) (Not Available in #30 AWG) <b>J</b> – M22759/33 600 Vrms Modified Cross-Linked Tefzel® (ETFE)	1 – White 2 – Yellow 5 – Color-Coded Stripes Per MIL-STD-681 (#26 gage only) 7 – Ten Color Repeat	<b>18</b> Wire Length In Inches. "18" Specifies 18 Inches.
<i>Sample Part Number</i>						
<b>177-704H</b>	<b>25</b>	<b>S</b>	<b>6</b>	<b>K</b>	<b>1</b>	<b>– 18</b>

Dimensions in Inches (millimeters) are subject to change without notice.

# 177-140H and 177-704H MIL-DTL-83513 Type Micro-D Hermetic Connectors Solder Mount

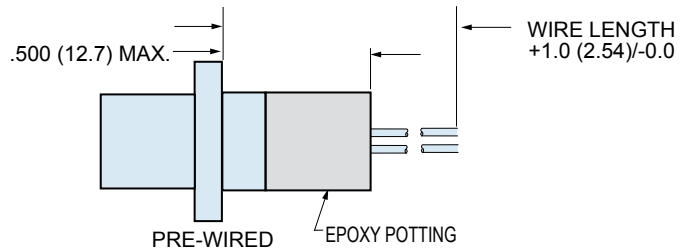
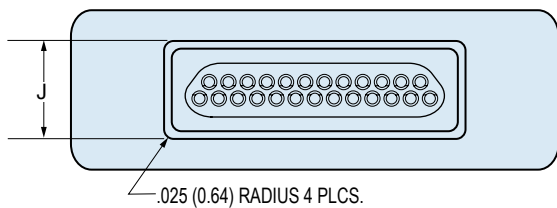
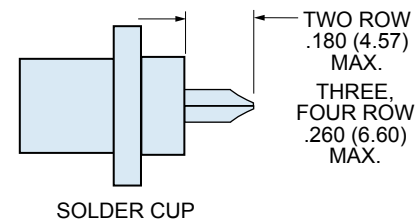
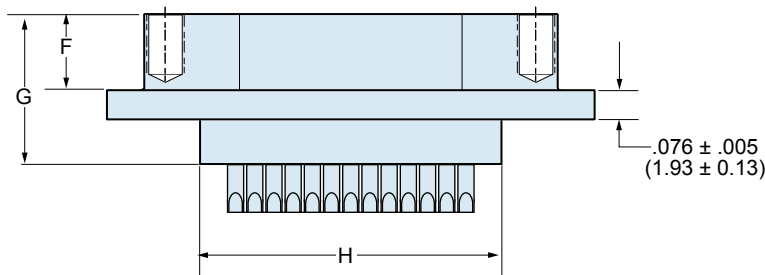
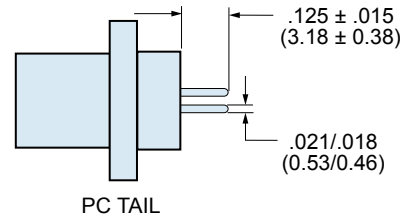
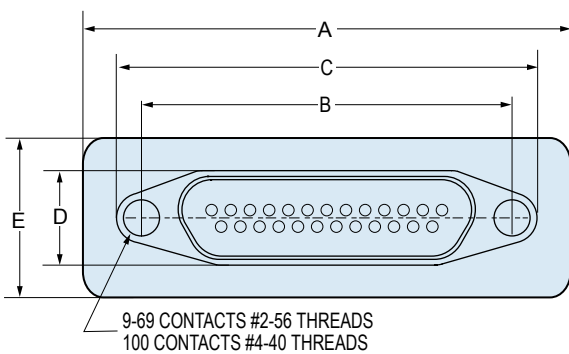

K

## DIMENSIONS

Layout	A Max.		B		C MAX.		D Max.		E Max.		F		G Max.		H		J	
	In. ± .005	mm. ± 0.13	In. ± .005	mm. ± 0.13	In. ± .005	mm. ± 0.13	In.	mm.	In.	mm.	In. ± .004	mm. ± 0.10	In.	mm.	In. ± .004	mm. ± 0.10	In. ± .004	mm. ± 0.10
<b>9S</b>	.785	19.94	.565	14.35	.695	14.35	.250	6.35	.310	7.87	.195	4.95	.394	10.01	.398	10.11	.268	6.81
<b>15S</b>	1.030	26.16	.715	18.16	.855	21.71	.250	6.35	.425	10.80	.195	4.95	.394	10.01	.535	13.59	.255	6.48
<b>21S</b>	1.180	29.97	.865	21.97	1.005	25.53	.250	6.35	.425	10.80	.195	4.95	.394	10.01	.750	19.05	.255	6.48
<b>25S</b>	1.280	32.51	.965	24.51	1.105	28.06	.250	6.35	.425	10.80	.195	4.95	.394	10.01	.785	19.94	.255	6.48
<b>31S</b>	1.430	36.32	1.115	28.32	1.255	31.88	.250	6.35	.425	10.80	.195	4.95	.394	10.01	.935	23.75	.255	6.48
<b>37S</b>	1.580	40.13	1.265	32.13	1.425	36.20	.250	6.35	.425	10.80	.195	4.95	.394	10.01	1.085	27.56	.255	6.48
<b>51S</b> 2 row	1.930	49.02	1.615	41.02	1.775	45.09	.310	7.87	.425	10.80	.199	5.05	.394	10.01	1.435	36.45	.250	6.35
<b>51S</b> 3 row	1.530	38.86	1.215	30.86	1.361	34.57	.310	7.87	.468	11.89	.199	5.05	.394	10.01	1.032	33.101	.300	7.62
<b>100S</b>	2.260	57.40	1.800	45.72	2.010	51.05	.330	8.38	.517	13.13	.199	5.05	.394	10.01	1.765	44.8	.355	9.02

Dimensions in Inches (millimeters) are subject to change without notice.





## 177-705H and 177-706H MIL-DTL-83513 Type Micro-D Hermetic Connectors Rear Panel Mount with O-Ring

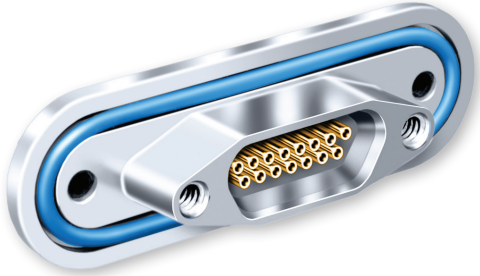

**Fluorosilicone O-Ring** eliminates the cost of soldering the connector to a bulkhead.

**Kovar® Shells and Contacts** comply with applicable MIL-DTL-83513 requirements and are 100% intermateable with standard connectors.

**Solder Cup, PC Tail or Pre-Wired and Fully Potted**

Suitable for #26 gage wire or smaller, solder cup versions feature gold-plated contacts. Choose PC tails for attachment to flex circuits or rigid boards. Solder cup versions are also available pre-wired and potted.

### HOW TO ORDER SOLDER CUP AND PC TAIL CONNECTORS

Series	Layout Number of Contacts	Contact Type	Mounting Threads	O-Ring Material
<b>177-705H</b> Micro-D Hermetic Socket Receptacle, Rear Panel Mount with O-Ring, Solder Cup or PC Tail	<b>9</b> <b>15</b> <b>21</b> <b>25</b> <b>31</b> <b>37</b> <b>51-2</b> <b>51</b> <b>100</b>	<b>SS</b> – Solder Cup, Socket <b>SP</b> – PC Tail, Socket	<b>U</b> – #4 - 40 UNC <b>M</b> – M3 Metric	<b>C</b> = Fluorosilicone, Conductive (Choseal 1298) <b>E</b> = Epdm (Ethylene-Propylene) <b>V</b> = Viton (Fluorocarbon; Fkm) <b>N</b> = Nitrile (Buna-N) <b>S</b> = Silicone (ZZ-R-765) <b>B</b> = Butyl Rubber (Iir) <b>K</b> = Kalrez (Ffkm)
<b>Sample Part Number</b>				
<b>177-705H</b>	<b>15</b>	<b>SS</b>	<b>U</b>	<b>-V</b>

### HOW TO ORDER PRE-WIRED CONNECTORS

Series	Layout	Contact Type	Wire Gage (AWG)	Wire Type	Wire Color	Wire Length Inches	Mounting Threads	O-Ring Material
<b>177-706H</b>	<b>9</b> <b>15</b> <b>21</b> <b>25</b> <b>31</b> <b>37</b> <b>51-2</b> <b>51</b> <b>100</b>	<b>S</b> – Socket Contacts Pre-Wired	<b>6</b> – #26 <b>8</b> – #28 <b>0</b> – #30	<b>K</b> – M22759/11 600 Vrms Teflon (TFE) (Not Available in #30 AWG) <b>J</b> – M22759/33 600 Vrms Modified Cross-Linked Tefzel (ETFE)	<b>1</b> – White <b>2</b> – Yellow <b>5</b> – Color-Coded Stripes Per MIL-STD-681 (#26 gage only) <b>7</b> – Ten Color Repeat	<b>18</b> Wire Length In Inches. "18" Specifies 18 Inches.	<b>M</b> - M3 Metric, Omit for #4-40 UNC	<b>C</b> = Fluorosilicone, Conductive <b>E</b> = EPDM (Ethylene-Propylene) <b>V</b> = Viton (Fluorocarbon; FKM) <b>N</b> = Nitrile (BUNA-N) <b>S</b> = Silicone (ZZ-R-765) <b>B</b> = Butyl Rubber (IIR) <b>K</b> = Kalrez (FFKM)
<b>Sample Part Number</b>								
<b>177-706H</b>	<b>25</b>	<b>S</b>	<b>6</b>	<b>K</b>	<b>1</b>	<b>- 18</b>	<b>M</b>	<b>-V</b>

Dimensions in Inches (millimeters) are subject to change without notice.

177-705H and 177-706H  
MIL-DTL-83513 Type Micro-D Hermetic Connectors  
Rear Panel Mount with O-Ring

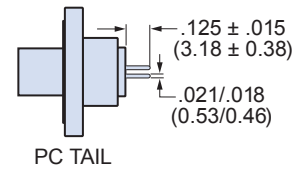
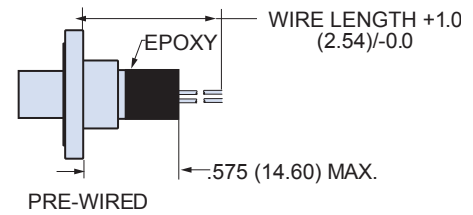
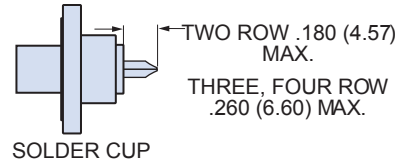
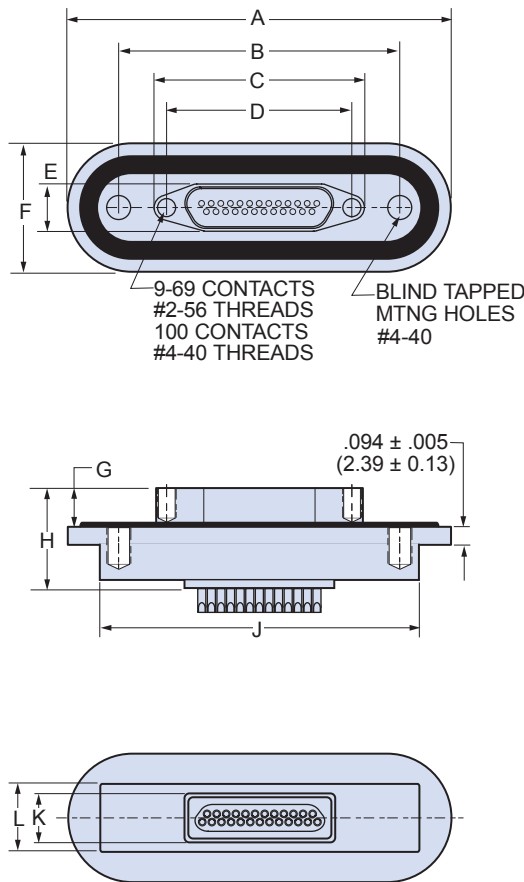

K

DIMENSIONS

Layout	A Max.		B		C MAX.		D		E MAX.		F Max.		G		H Max.		J		K		L Max.	
	In.	mm.	In. ±.005	mm. ±0.13	In.	mm.	In. ±.003	mm. ±0.08	In.	mm.	In.	mm.	In. ±.004	mm. ±0.10	In.	mm.	In.	mm.	In. ±.004	mm. ±0.10	In.	mm.
<b>9S</b>	1.488	37.80	1.011	25.67	.728	18.49	.565	14.35	.250	6.35	.675	17.14	.195	4.95	.526	13.36	1.254	31.85	.257	6.89	.358	9.09
<b>15S</b>	1.638	41.61	1.161	29.48	.878	22.30	.715	18.16	.250	6.35	.675	17.14	.195	4.95	.526	13.36	1.414	36.91	.257	6.89	.358	9.09
<b>21S</b>	1.788	45.42	1.311	33.29	1.028	32.51	.865	21.97	.250	6.35	.675	17.14	.195	4.95	.526	13.36	1.564	39.72	.257	6.89	.358	9.09
<b>25S</b>	1.888	47.96	1.411	35.83	1.128	28.65	.965	24.51	.250	6.35	.675	17.14	.195	4.95	.526	13.36	1.664	42.26	.257	6.89	.358	9.09
<b>31S</b>	2.038	51.76	1.561	39.64	1.278	32.46	1.115	28.32	.250	6.35	.675	17.14	.195	4.95	.526	13.36	1.814	46.07	.257	6.89	.358	9.09
<b>37S</b>	2.188	55.57	1.711	43.45	1.428	36.27	1.265	32.13	.250	6.35	.675	17.14	.195	4.95	.526	13.36	1.984	50.39	.257	6.89	.358	9.09
<b>51S 2 Row</b>	2.538	64.47	2.061	52.35	1.778	45.16	1.615	41.02	.250	6.35	.675	17.14	.195	4.95	.526	13.36	2.334	59.28	.257	6.89	.358	9.09
<b>51S 3 Row</b>	2.138	54.30	1.661	42.19	1.378	35.00	1.215	30.86	.310	7.87	.715	18.16	.195	4.95	.526	13.36	1.920	48.77	.257	6.89	.358	9.09
<b>100S</b>	2.820	71.63	2.312	58.72	2.002	50.85	1.800	45.72	.330	8.38	.795	20.19	.195	4.95	.599	15.21	2.569	65.25	.257	6.89	.358	9.09

Dimensions in Inches (millimeters) are subject to change without notice.



177-705H and 177-706H  
MIL-DTL-83513 Type Micro-D Hermetic Connectors  
Rear Panel Mount with O-Ring

PANEL CUTOUT DIMENSIONS FOR 177-705 AND 177-706

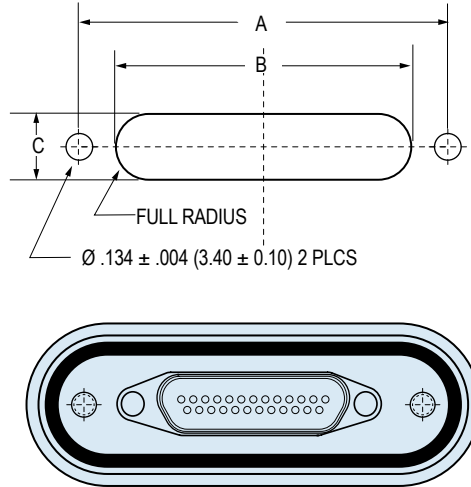

K

Layout	A		B		C	
	In. ± .003	mm. ±0.08	In. +.005 / -0.0	mm. +0.13 / -0.0	In. + .005 / -0.0	mm. +0.13 / -0.0
9	1.011	25.69	.731	18.56	.252	6.40
15	1.161	29.50	.881	22.37	.252	6.40
21	1.311	33.31	1.031	26.18	.252	6.40
25	1.411	35.85	1.131	28.72	.252	6.40
31	1.561	39.66	1.281	32.53	.252	6.40
37	1.711	43.47	1.431	36.34	.252	6.40
51 2 row	2.061	52.35	1.781	45.24	.252	6.40
51 3 row	1.661	42.19	1.381	35.08	.310	7.87
100	2.312	58.72	2.005	50.93	.330	8.38

Dimensions in Inches (millimeters) are subject to change without notice.

**177-232**  
**MIL-DTL-83513 Type Micro-D Hermetic Connectors**  
**Socket Shell, Size 37 Front Mount**



**Conductive Elastomer O-Ring** eliminates the cost of soldering the connector to a bulkhead.

**Kovar® Shells and Contacts** comply with applicable MIL-DTL-83513 requirements and are 100% intermateable with standard connectors.

HOW TO ORDER PC TAIL CONNECTORS	
Series	
177-232	
Micro-D Hermetic Socket Shell, Size 37, Front Mount	
Sample Part Number	
177-232	

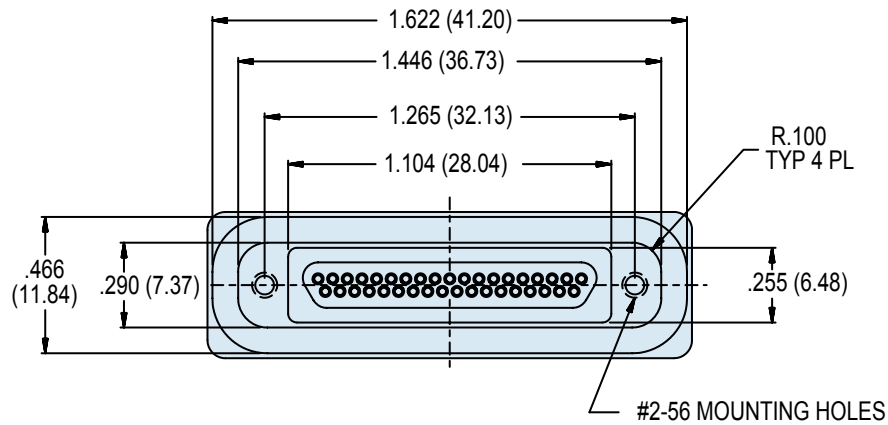
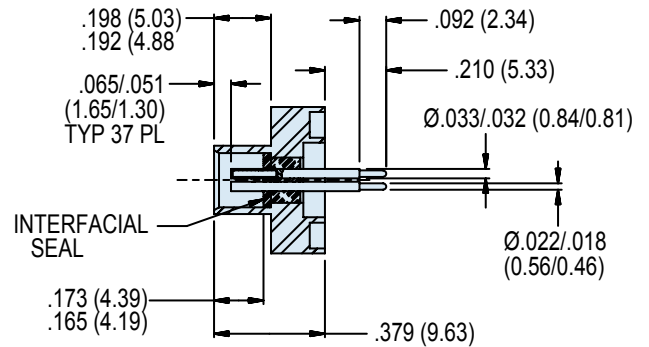
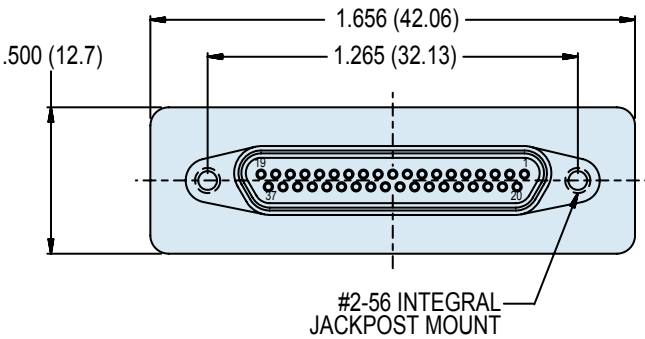

Dimensions in Inches (millimeters) are subject to change without notice.





# 177-859 MIL-DTL-83513 Type Micro-D Hermetic Connectors Socket Shell, Size 9-21 Front Mount



**Fluorosilicone O-Ring** eliminates the cost of soldering the connector to a bulkhead.

**Kovar® Shells and Contacts** comply with applicable MIL-DTL-83513 requirements and are 100% intermateable with standard connectors.

### DIMENSIONS

Layout	A Max.		B		C MAX.		D		E MAX.		F Max.	
	In.	mm.	In. ±.005	mm. ±0.13	In.	mm.	In. ±.003	mm. ±0.08	In.	mm.	In.	mm.
<b>9</b>	1.176	29.87	.565	14.35	.380	9.65	.600	15.24	.776	19.71	.976	24.79
<b>15</b>	1.326	31.39	.715	18.16	.530	13.46	.750	19.05	.926	23.52	1.126	28.60
<b>21</b>	1.416	35.97	.865	21.97	.680	17.27	.840	21.34	1.016	25.81	1.216	30.89

K

### HOW TO ORDER SOLDER CUP CONNECTORS

Series	Layout Number of Contacts	O-Ring Material
<b>177-859</b> Micro-D Hermetic Socket Shell, Size 9-12, Front Mount	<b>-9</b> <b>-15</b> <b>-21</b>	<b>-1</b> – Viton® <b>-2</b> – Nitrile <b>-3</b> – Fluorosilicone <b>-4</b> – Silicone <b>-5</b> – Conductive
Sample Part Number		
<b>177-859</b>	<b>-15</b>	<b>-1</b>

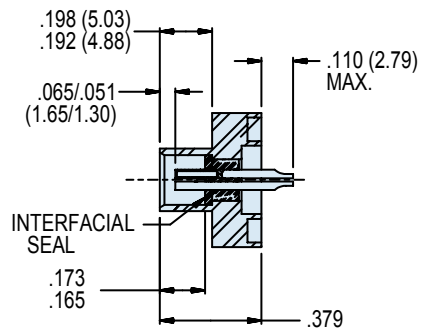
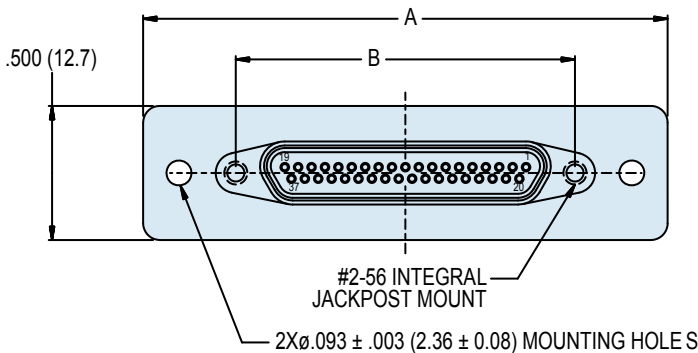
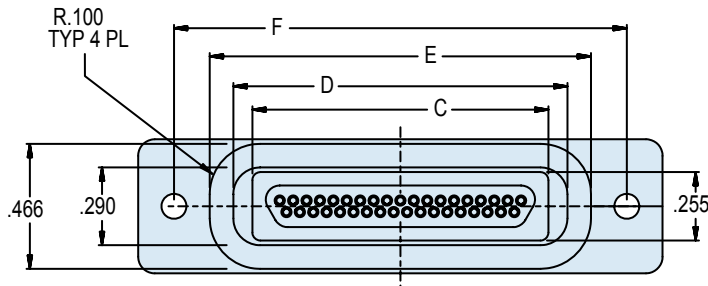

Dimensions in Inches (millimeters) are subject to change without notice.

**Series 79  
Micro-Crimp Mateable, Hermetic Connectors  
General Information**



**Series 79 Hermetic Micro-Crimp Mateable Receptacles**

Glenair Micro-Crimp mateable hermetic socket receptacles with glass to metal seals are offered in 31 insert arrangements from 5 to 102 contacts. Available with O-Ring mount with optional jackpost hardware. Solder cup and pre-wired versions available.

Quick Selection Guide		
Part Number	Description	Page
	Series 79 Micro-Crimp Mateable, Hermetic Connectors General Information	L-2
	Series 79 Micro-Crimp Mateable, Recommended Panel Cutouts	L-3
	Series 79 Micro-Crimp Mateable, Insert Arrangements	L-5
	Series 79 Micro-Crimp Mateable, Connectors for Space Flight	L-8
<b>790-066</b>	Hermetic Rear Panel Mount Micro-Crimp Mateable, Receptacle. Pin Faced with Solder Cup and PC Termination Contacts	L-9
<b>790-081</b>	Hermetic Rear Panel Mount Micro-Crimp Mateable, Receptacle. Pin Faced with Pre-wired Terminations	L-13



## Series 79 Micro-Crimp Mateable, Hermetic Connectors General Information

### The High-Density, High Performance Hermetic Rectangular

# MICROCRIMP®

Meet the newest member of Glenair's ultraminiature connector family, the Series 79 Micro-Crimp. Environmental versions of the Micro-Crimp feature crimp, rear-release size #23 contacts on .075 inch (1.9 mm) spacing, as well as size #12 and #16 power contacts in a range of hybrid layouts. Hermetic versions of these high contact density connectors also feature rugged construction for demanding applications and, of course glass-to-metal hermetic sealing for severe environmental and pressure differential operating conditions. Designed for use in vacuum chambers and other pressurized systems, Glenair Micro-Crimp Hermetic Connectors offer outstanding performance in a lightweight microminiature package. The basic mounting configuration, an O-Ring equipped rear panel mount design may be customized for unique application environments. Specials, including weld mount versions are also available

- Pin Receptacles
- Glass to Metal Seals
- 31 insert arrangements, from 5 to 102 contacts
- O-Ring Mount;  
Jackposts Options
- Solder Cup, PC Tail, and Pre-Wired Connectors

L

*Hermetic Micro-Crimp mateable, solutions available in 31 insert arrangements, from 5 to 102 contacts.*





**Series 79**  
**Micro-Crimp Mateable, Hermetic Receptacles**  
**Insert Arrangements**



Series 79  
 Micro-Crimp

**MICRO-CRIMP INSERT ARRANGEMENTS**

Shell Size	Contact Arrangement	No. of Contacts and Contact Size	Mating Face Pin Connector (Socket Numbers are Reversed)
A	A-5	5 #23 CONTACTS	
B	B-2P2	2 #16 CONTACTS	
B	B-9	9 #23 CONTACTS	
C	C-13	13 #23 CONTACTS	
D	D-15	15 #23 CONTACTS	
D	D-3P3	3 #16 CONTACTS	
D	D-7P2	5 #23 CONTACTS 2 #16 CONTACTS	
E	E-11P2	9 #23 CONTACTS 2 #16 CONTACTS	
E	E-19	19 #23 CONTACTS	
E	E-7P3	4 #23 CONTACTS 3 #16 CONTACTS	
F	F-15P2	13 #23 CONTACTS 2 #16 CONTACTS	

**L**



**Series 79**  
**Micro-Crimp Mateable, Hermetic Receptacles**  
**Insert Arrangements**

**MICRO-CRIMP INSERT ARRANGEMENTS**

Shell Size	Contact Arrangement	No. of Contacts and Contact Size	Mating Face Pin Connector (Socket Numbers are Reversed)
F	F-23	23 #23 CONTACTS	
F	F-5P5	5 #16 CONTACTS	
G	G-33	33 #23 CONTACTS	
L	H	H-10P4 6 #23 CONTACTS 4 #12 CONTACTS	
	H	H-29P7 22 #23 CONTACTS 7 #16 CONTACTS	
H	H-36P2 34 #23 CONTACTS 2 #12 CONTACTS		
H	H-54P2 52 #23 CONTACTS 2 #16 CONTACTS		
H	H-5P5	5 #12 CONTACTS	

**Series 79**  
**Micro-Crimp Mateable, Hermetic Receptacles**  
**Insert Arrangements**



Series 79  
 Micro-Crimp

**MICRO-CRIMP INSERT ARRANGEMENTS**

Shell Size	Contact Arrangement	No. of Contacts and Contact Size	Mating Face Pin Connector (Socket Numbers are Reversed)
H	H-66	66 #23 CONTACTS	
J	J-17P4	13 #23 CONTACTS 4 #16 CONTACTS	
J	J-25P2	23 #23 CONTACTS 2 #16 CONTACTS	
J	J-33	33 #23 CONTACTS	
J	J-7P7	7 #16 CONTACTS	
K	K-27P4	23 #23 CONTACTS 4 #16 CONTACTS	
K	K-35P2	33 #23 CONTACTS 2 #16 CONTACTS	
K	K-43	43 #23 CONTACTS	

**L**



**Series 79**  
**Micro-Crimp Mateable, Hermetic Receptacles**  
**Insert Arrangements**

**MICRO-CRIMP INSERT ARRANGEMENTS**

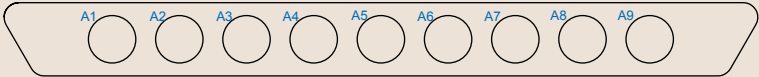
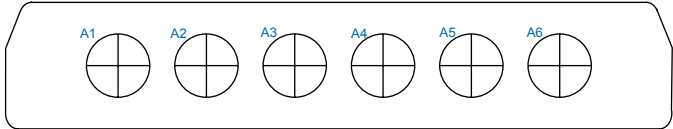
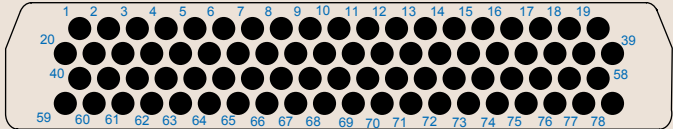
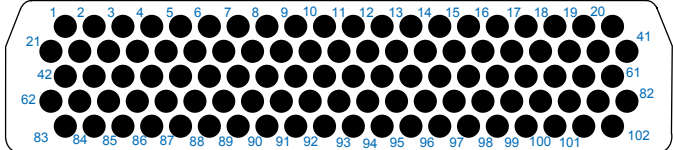
Shell Size	Contact Arrangement	No. of Contacts and Contact Size	Mating Face Pin Connector (Socket Numbers are Reversed)
K	K-9P9	9 #16 CONTACTS	
L	L-6P6	6 #12 CONTACTS	
L	L-78	78 #23 CONTACTS	
M	M-102	102 #23 CONTACTS	

L

## Series 79 Micro-Crimp Mateable, Recommended Panel Cut-Outs

ALL CUTOUTS FOR .063" (.070 MAX) THICK PANEL MOUNTING

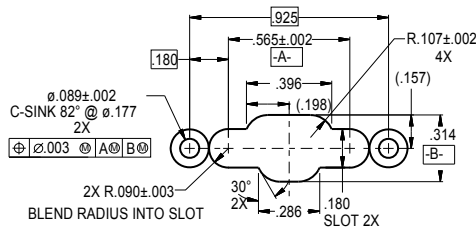

Shell Size A

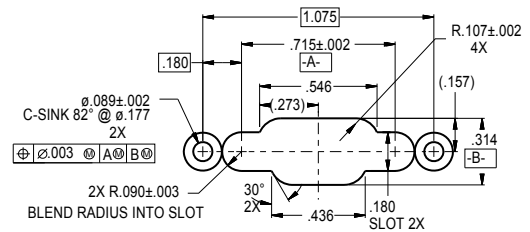

Shell Size B

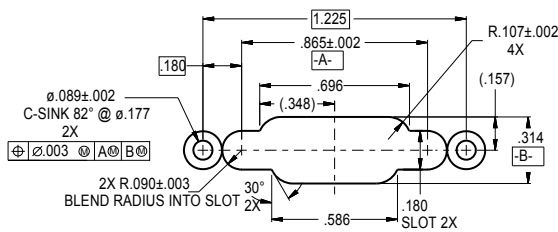

Shell Size C

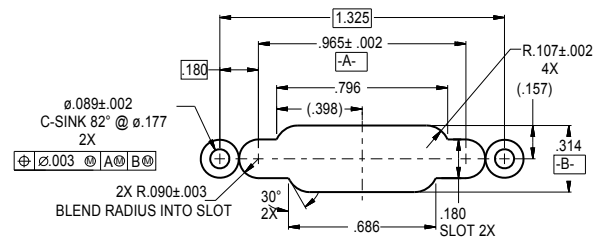

Shell Size D

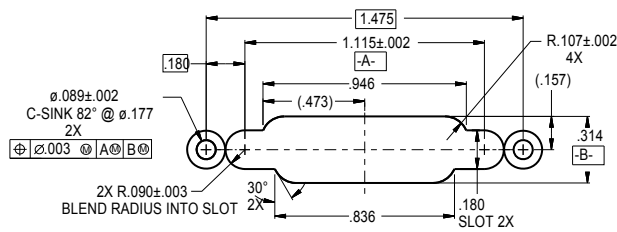

Shell Size E

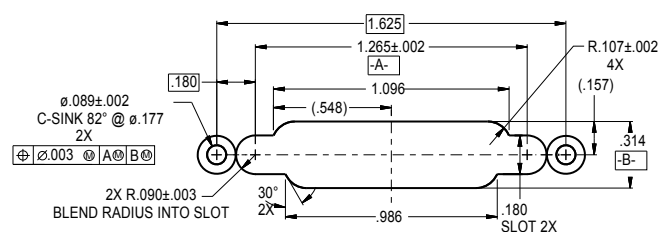

Shell Size F

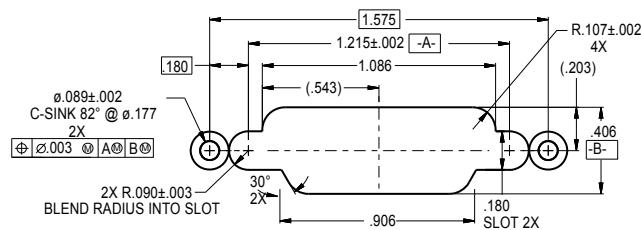

Shell Size G



**Series 79**  
**Micro-Crimp Mateable, Hermetic Receptacles**  
**Recommended Panel Cut-Outs**

**Series 79 Micro-Crimp Mateable, Recommended Panel Cut-Outs**

**ALL CUTOUTS FOR .063" (.070 MAX) THICK PANEL MOUNTING**

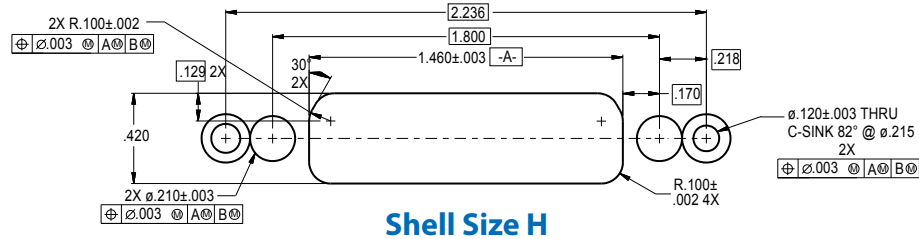

**Shell Size H**

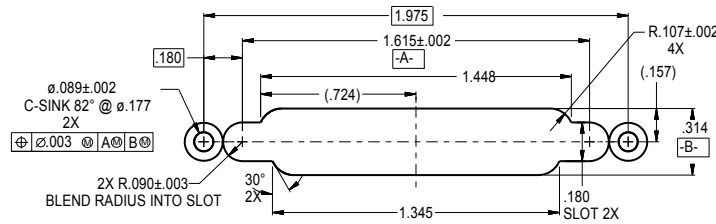

**Shell Size J**

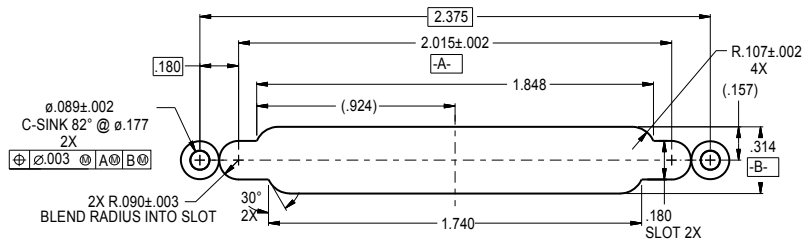

**Shell Size K**

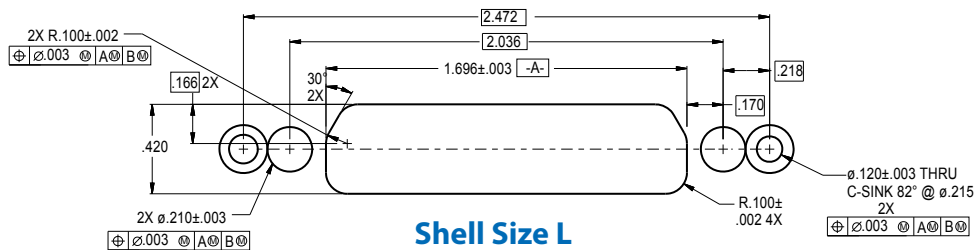

**Shell Size L**

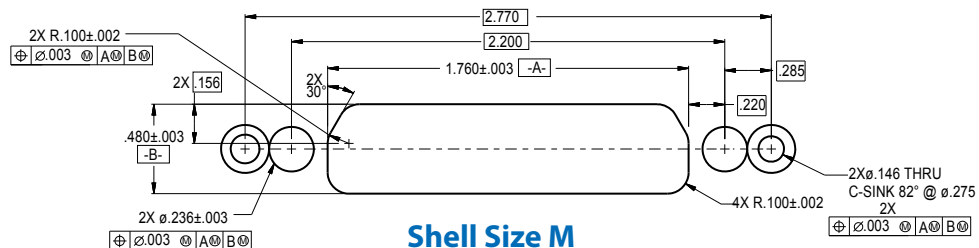

**Shell Size M**

L

## Space Grade Series 79 Micro-Crimp Connectors



Micro-D connectors are a popular choice for space flight. Their small size and reduced weight, combined with excellent shock and vibration performance, has led to their widespread use on space vehicles. The Micro-Crimp connector brings the benefits of a crimp, rear-release contact system to the Glenair Micro-D family. Connectors can be terminated onto complicated, multi-branch wiring harnesses without splicing or soldering.

### Five things you should know about Series 79 connectors for space flight

**1 Material Selection:** What materials are approved for space-grade connectors? What materials are prohibited? Does the Series 79 connector contain space-approved materials?

**2 Outgassing:** What is outgassing, why is it important, and how does it affect connector selection? Is special processing required to meet outgassing requirements?

**3 Screening:** What is NASA screening and what level of screening is required?

**4 Magnetic permeability:** Are nonmagnetic connectors required?

**5 Cryogenic exposure:** Are these connectors suitable for -200° C. exposure?

### HOW TO ORDER SPACE GRADE SERIES 79 CONNECTORS

#### Step 1: Find a Standard Part Number

Electroless nickel plated shells are preferred for space flight. Cadmium plating is prohibited.

#### Step 2: Select a NASA Screening Level

The term "Screening Level" refers to the final inspection procedure.

Level 1 for mission-critical highest reliability

Level 2 for high reliability

Level 3 for standard reliability

#### Step 3: Choose Outgassing Processing

A detailed explanation of outgassing is on the following pages. The fluorosilicone rubber seals commonly used on aerospace-grade connectors such as MIL-DTL-38999 and Series 79 connectors, along with certain bonding agents and inks, do not meet NASA outgassing requirements unless the connector is specially processed. Glenair outgassing tests have shown oven baking or thermal vacuum outgassing processing are sufficient to reduce outgassing levels to NASA standards. Oven baking is more economical than thermal vacuum outgassing.

#### Step 4: Select the Mod 429 Code that Matches the Desired Level of Screening and Outgassing

Use the following table to choose the right modification code. Add the mod code to the connector part number. Example: 790-066Z1K-9P9PN-**429C**

### NASA SCREENING LEVELS AND MODIFICATION CODES

NASA Screening Level	Special Screening Only		Special Screening Plus Outgassing Processing	
	Interfacial Seal is Installed	Interfacial Seal is Deleted	8 Hour Oven Bake 400° F.	Thermal Vacuum Outgassing 24 hrs. 125° C.
Level 1 Highest Reliability	Mod 429B	Mod 429F	Mod 429J	Mod 429C
Level 2 High Reliability	Mod 429	Mod 429D	Mod 429K	Mod 429A
Level 3 Standard Reliability	(Use standard part no.)	Mod 432	Mod 186	Mod 186M





790-066

Series 79 Micro-Crimp Mateable, Rear Panel Mount  
Hermetic Receptacle, Pin Face  
with Solder Cups

**Basic Part Number**  
790-066

**Shell Size**  
Table I  
Page L-11  
Z1

**Contact Type**  
C = Pin, PC Tail  
P = Pin, Solder Cup  
K

**Mating Hardware Option**  
N = No Hardware  
P = Jackpost  
G = Male Guide Pins  
S = Female Guide Sockets  
See Page L-12

**Finish**  
Z1 = Passivate  
ZL = Nickel Plate

**Arrangement**  
See Page L-3 thru L-6  
- 9P9 C N

PC Tail Dimensions	
Contact Size	Ø T
23	.022 (.56) .018 (.46)
16	.064 (1.63) .061 (1.55)
12	.095 (2.41) .093 (2.36)

Mounting Hardware	
<b>P</b> Jackpost	Connector supplies with non-removable jackpost. Shell size "M" has 6-32-UNC thread. Shell sizes "H" and "L" have 4-40 UNC-2B thread. all other sizes have 2-56 UNC-2B thread.
<b>G</b> Guide Pin	Connector supplied with non-removable guide pins for blind mate applications. Mates with option "S" guide socket on corresponding plug connector.
<b>S</b> Guide Socket	Connector supplied with non-removable guide sockets for blind mate applications. Mates with option "G" guide pin on corresponding plug connector.

Shell Size A, B, C, D, E, F, J & K  
See Table I For Dimensions

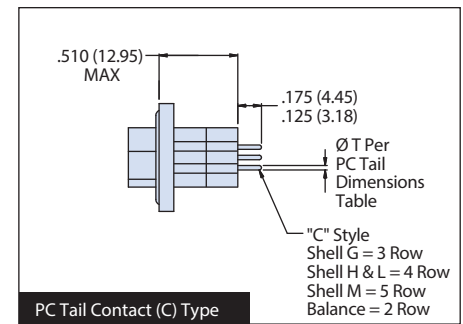
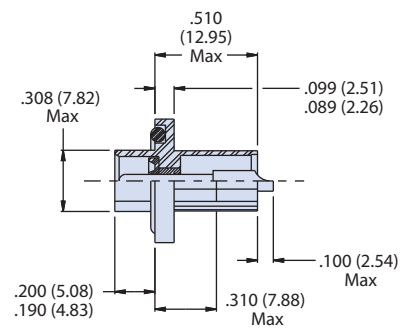
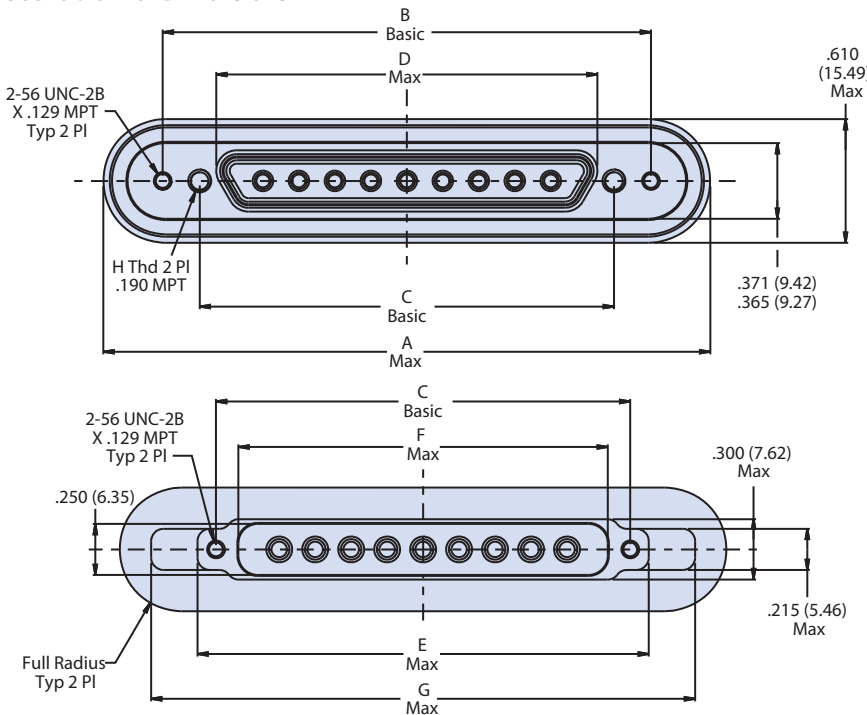

APPLICATION NOTES

- Material/Finish:  
Shell\* - 300 Series CRES/passivate or 300 Series CRES/Nickel Plate  
Contacts - Nickel iron alloy/gold plate  
Insulator - Individual glass beads/N.A.  
Seals - Fluorosilicone blend/N.A.  
Mating Hardware - CRES/passivated  
\*Consult factory for other shell finishes and O-Ring materials.
- Metric dimensions (mm) are indicated in parentheses.
- See Pages L-7 and L-8 for panel cut-out information.
- Test Criteria:  
Hermeticity -  $<1 \times 10^{-5}$  scc He/sec @1 ATM Delta  
DWV - #23 pins: 500 VAC pin-to-shell  
#16 pins: 1800 VAC pin-to-shell  
#12 pins: 1800 VAC pin-to-shell  
I.R. - 5,000 megohms minimum @500 VDC
- Glenair 790-066 will mate with any series 79 plug with socket contacts and same shell and insert, and is designed to utilize 799-016 EMI backshells.

790-066

Series 79 Micro-Crimp Mateable, Rear Panel Mount  
Hermetic Receptacle, Pin Face  
with Solder Cups



Series 79  
Micro-Crimp

Shell Size G

See Table II For Dimensions

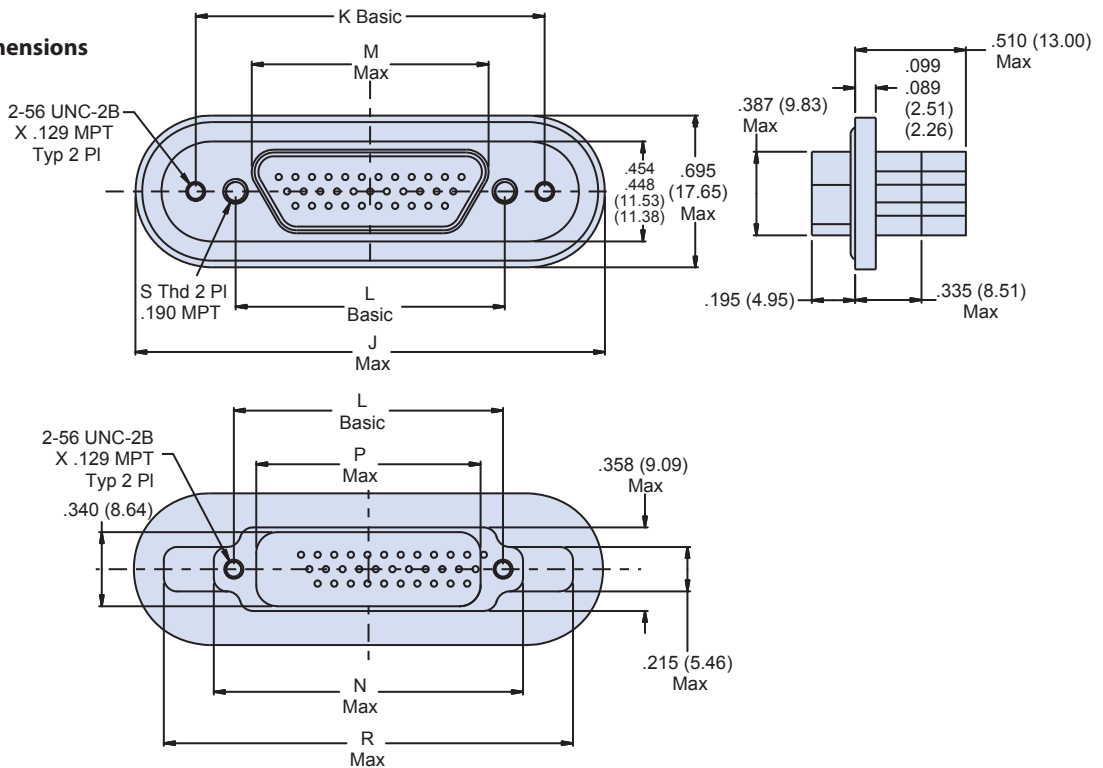

L

Shell Size H & L

See Table II For Dimensions

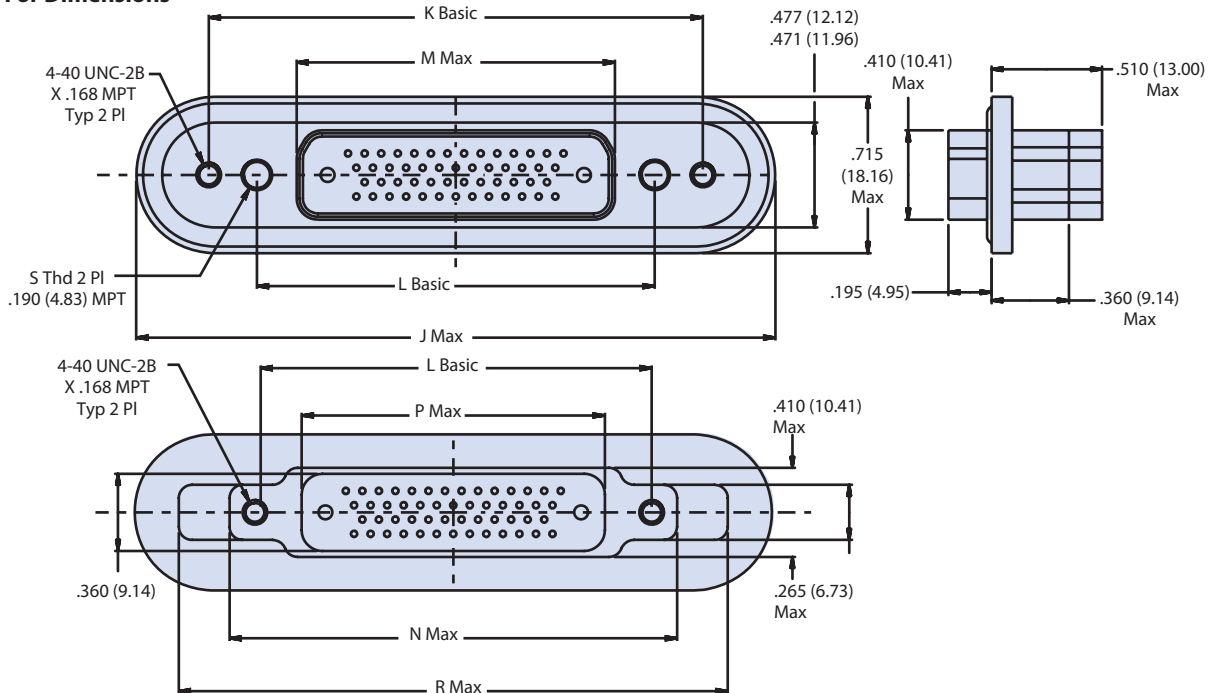

Series 79  
Micro-Crimp

**790-066**  
**Series 79 Micro-Crimp Mateable, Rear Panel Mount**  
**Hermetic Receptacle, Pin Face**  
**with Solder Cups**

**Shell Size M (See Table II For Dimensions)**

**TABLE I: SHELL SIZE A, B, C, D, E, F, J AND K CONNECTOR DIMENSIONS**

Shell Size	A OAL	B BASIC	C BASIC	D MAX	E MAX	F MAX	G MAX	H TYP UNC 2-B
A	1.490 (37.85)	.925 (23.50)	.565 (14.35)	.401 (10.19)	.750 (19.05)	.350 (8.89)	1.215 (30.86)	#4-40
B	1.680 (42.67)	1.075 (27.31)	.715 (18.16)	.551 (14.00)	.910 (23.11)	.500 (12.70)	1.365 (34.67)	#4-40
C	1.785 (45.34)	1.225 (31.12)	.865 (21.97)	.701 (17.81)	1.060 (26.92)	.650 (16.51)	1.515 (38.48)	#4-40
D	1.975 (50.17)	1.325 (33.66)	.965 (24.51)	.801 (20.35)	1.160 (29.46)	.750 (19.05)	1.615 (41.02)	#4-40
E	2.075 (52.71)	1.475 (37.47)	1.115 (28.32)	.951 (24.16)	1.310 (33.27)	.900 (22.86)	1.765 (44.83)	#4-40
F	2.175 (55.25)	1.625 (41.28)	1.265 (32.13)	1.101 (27.97)	1.460 (37.08)	1.050 (26.67)	1.915 (48.64)	#4-40
J	2.665 (67.69)	1.975 (50.17)	1.615 (41.02)	1.460 (37.08)	1.810 (45.97)	1.405 (35.69)	2.265 (57.53)	#4-40
K	2.960 (75.18)	2.375 (60.33)	2.015 (51.18)	1.860 (47.24)	2.210 (56.13)	1.805 (45.85)	2.665 (67.69)	#4-40

**CONTACTS AND WIRE SIZES AVAILABLE**

Contact Sizes	Wire Sizes Accomodated
#23	26, 24, 22
#16	20, 18, 16
#12	14, 12

**TABLE II: SHELL SIZE G, H, L AND M CONNECTOR DIMENSIONS**

Shell Size	J OAL	K BASIC	L BASIC	M MAX	N MAX	P MAX	R MAX	S TYP UNC 2-B
G	2.130 (54.10)	1.575 (40.01)	1.215 (30.86)	1.079 (27.41)	1.410 (35.81)	1.020 (25.91)	1.861 (47.27)	#4-40
H	2.900 (73.66)	2.236 (56.79)	1.800 (45.72)	1.450 (36.83)	2.045 (51.94)	1.385 (35.18)	2.500 (63.50)	#6-32
L	3.100 (78.74)	2.472 (62.79)	2.036 (51.74)	1.686 (42.82)	2.281 (57.94)	1.625 (41.28)	2.736 (69.49)	#6-32
M	3.475 (88.27)	2.770 (70.36)	2.200 (55.88)	1.745 (44.32)	2.485 (63.12)	1.690 (42.93)	3.085 (78.36)	#8-32

© 2013 Glenair, Inc.

CAGE CODE 06324

Printed in U.S.A.

**GLENAIR, INC. • 1211 AIR WAY • GLENDALE, CA 91201-2497 • 818-247-6000 • FAX 818-500-9912**

**L-12**

E-Mail: [sales@glenair.com](mailto:sales@glenair.com)

790-081

Series 79 Micro-Crimp Mateable, Rear Panel Mount  
Hermetic Receptacle, Pin Face  
with Pre-Wired Terminations



Series 79  
Micro-Crimp

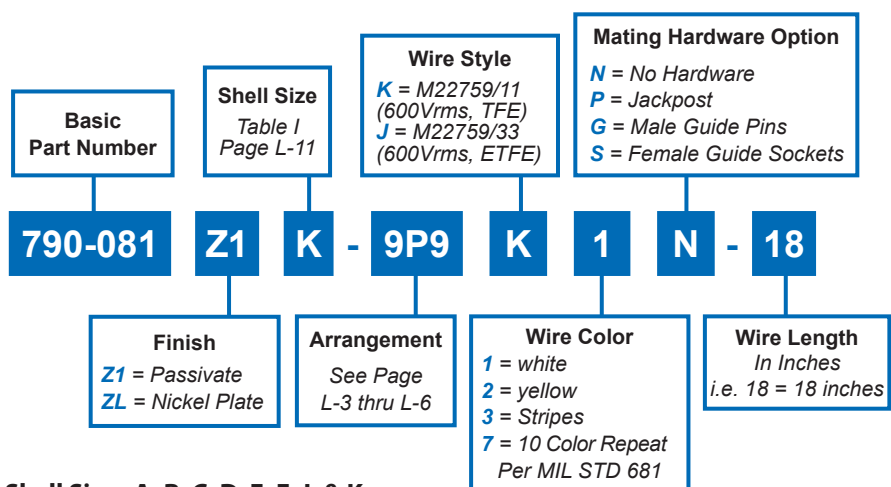

Mounting Hardware	
<b>P</b> Jackpost	Connector supplies with non-removable jackpost. Shell size "M" has 6-32-UNC thread. Shell sizes "H" and "L" have 4-40 UNC-2B thread. all other sizes have 2-56 UNC-2B thread.
<b>G</b> Guide Pin	Connector supplied with non-removable guide pins for blind mate applications. Mates with option "S" guide socket on corresponding plug connector.
<b>S</b> Guide Socket	Connector supplied with non-removable guide sockets for blind mate applications. Mates with option "G" guide pin on corresponding plug connector.

Shell Sizes A, B, C, D, E, F, J, & K  
(See Table I For Dimensions)

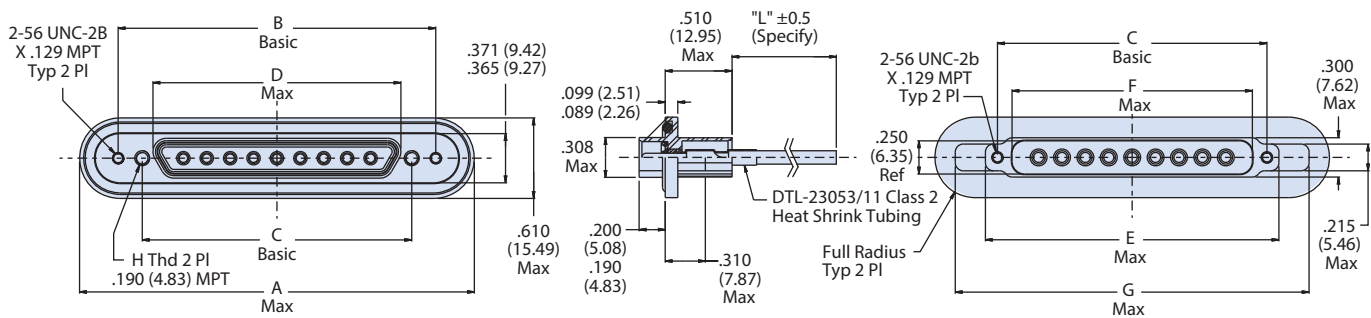

L

CONTACTS AND STANDARD WIRE SIZES AVAILABLE**	
Contact Size	Wire Size (AWG)
#23	22
#16	16
#12	12

\*\* Consult factory for other wire sizes (special)

TABLE I: SHELL SIZE A, B, C, D, E, F, J, AND K DIMENSIONS								
Shell Sizes	A Oal	B Bsc	C Bsc	D Max	E Max	F Max	G Max	H Typ Unc 2-B
A	1.490 (37.85)	0.925 (23.50)	0.565 (14.35)	0.401 (10.19)	0.760 (19.30)	0.350 (8.89)	1.215 (30.86)	#4-40
B	1.680 (42.67)	1.075 (27.30)	0.715 (18.16)	0.551 (14.00)	0.910 (23.11)	0.500 (12.70)	1.365 (34.67)	
C	1.785 (45.34)	1.225 (31.12)	0.865 (21.97)	0.701 (17.81)	1.060 (26.92)	0.650 (16.51)	1.515 (38.48)	
D	1.975 (50.17)	1.325 (33.65)	0.965 (24.51)	0.801 (20.35)	1.160 (29.46)	0.750 (19.05)	1.615 (41.02)	
E	2.075 (52.71)	1.475 (37.47)	1.115 (28.32)	0.951 (24.16)	1.310 (33.27)	0.900 (22.86)	1.765 (44.83)	
F	2.175 (55.24)	1.625 (41.28)	1.265 (32.13)	1.101 (27.97)	1.460 (37.08)	1.050 (26.67)	1.915 (48.64)	
J	2.665 (67.69)	1.975 (50.17)	1.615 (41.02)	1.460 (37.08)	1.810 (45.97)	1.405 (35.69)	2.265 (57.53)	
K	2.960 (75.18)	2.375 (60.33)	2.015 (51.18)	1.860 (47.24)	2.210 (56.13)	1.805 (45.85)	2.665 (67.69)	

APPLICATION NOTES

- Material/Finish:  
Shell\* - 300 Series CRES/passivate or 300 Series CRES/Nickel Plate  
Contacts - Nickel iron alloy/gold plate  
Insulator - Individual glass beads/N.A.  
Seals - Fluorosilicone blend/N.A.  
Mating Hardware - CRES/passivated  
\*Consult factory for other shell finishes and O-Ring materials.
- Metric dimensions (mm) are indicated in parentheses.
- See Pages L-7 and L-8 for panel cut-out information.
- Test Criteria:  
Hermeticity - <math>1 \times 10^{-5}</math> scc He/sec @1 ATM Delta  
DWV - #23 pins: 500 VAC pin-to-shell  
#16 pins: 1800 VAC pin-to-shell  
#12 pins: 1800 VAC pin-to-shell  
I.R. - 5,000 megohms minimum @500 VDC
- Glenair 790-081 will mate with any series 79 plug with socket contacts and same shell and insert, and is designed to utilize 799-016 EMI backshells.



790-081

Series 79 Micro-Crimp Mateable, Rear Panel Mount  
Hermetic Receptacle, Pin Face  
with Pre-Wired Terminations

Shell Sizes G (See Table II For Dimensions)

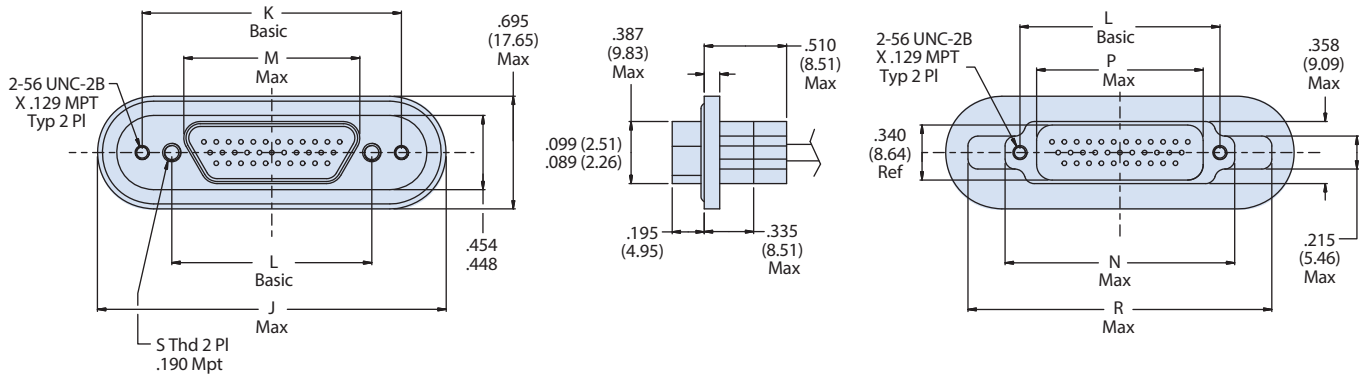

Shell Sizes H and L (See Table II For Dimensions)

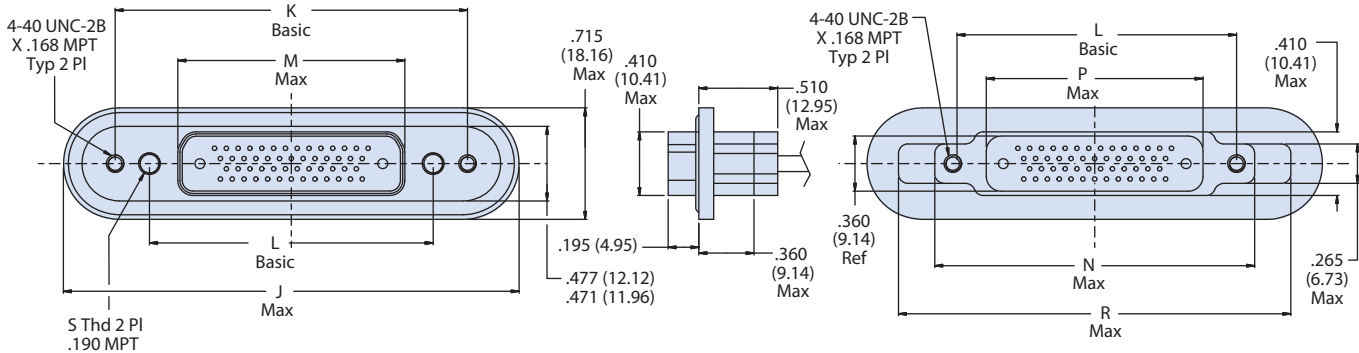

Shell Sizes M (See Table II For Dimensions)

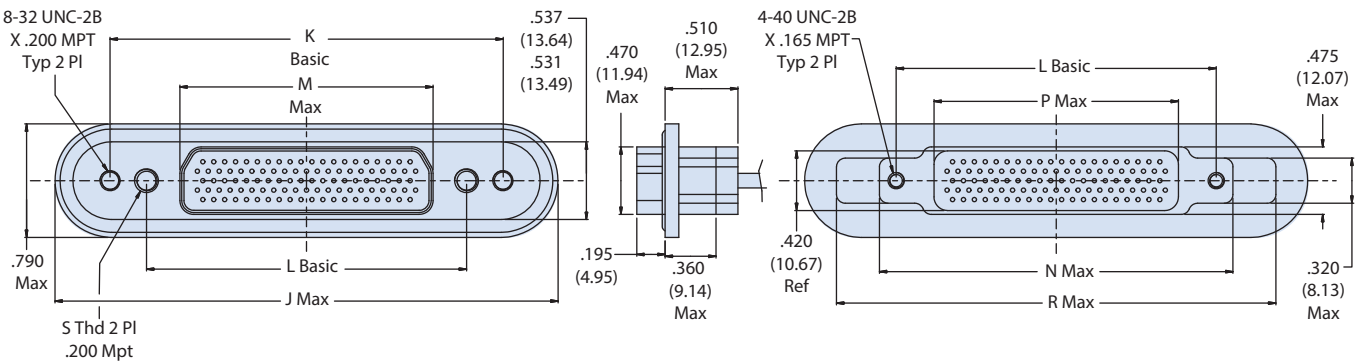

TABLE II: SHELL SIZE G, H, L AND M DIMENSIONS

Shell Size	J Oal	K Bsc	L Bsc	M Max	N Max	P Max	R Max	S Typ UNC 2-B
G	2.130 (54.10)	1.575 (40.00)	1.215 (30.86)	1.079 (27.41)	1.410 (35.81)	1.020 (25.91)	1.861 (47.27)	#4-40
H	2.900 (73.66)	2.236 (56.79)	1.800 (45.72)	1.450 (36.83)	2.045 (51.94)	1.385 (35.18)	2.500 (63.50)	#6-32
L	3.100 (78.74)	2.472 (62.79)	2.036 (51.71)	1.686 (42.82)	2.281 (57.94)	1.625 (41.28)	2.736 (69.49)	#6-32
M	3.475 (88.27)	2.770 (70.36)	2.200 (55.88)	1.745 (44.32)	2.485 (63.12)	1.690 (42.93)	3.085 (78.36)	#8-32



SERIES 970  
HIGH AMPACITY,  
HARSH ENVIRONMENT

# POWERTRIP™

*The power connector  
for extreme environments—now  
available in hermetic versions*



## Protect circuits with Series 970 PowerTrip™ connectors

The George HW Bush, pictured above, is the first US Navy surface ship to use the Series 970 PowerTrip™ connector. Series 970 connectors fill the need for a military-grade harsh environment power connector with improved mechanical, environmental and electrical performance. PowerTrip™ also delivers reduced size and weight compared to lower-density 5015 type power connectors. Available hermetic versions feature triple-start mating threads, high density insert arrangements and advanced EMI protection. The PowerTrip™ connector is ideal for power distribution units, hybrid electric drives, motors, and other high current, high-reliability applications.



**G**lenair®

Glenair, Inc.  
1211 Air Way  
Glendale, CA  
91201-2497  
818-247-6000  
sales@glenair.com  
www.glenair.com

## Series 970 PowerTrip™ Hermetic Connectors



### **Protect High-Current Circuits with Glenair's Series 970 PowerTrip™ Connectors**

The Series 970 PowerTrip™ connector fills the need for a military-grade harsh environment power connector with improved mechanical, environmental and electrical performance. Environmental versions and Hermetic versions share high performance Features such as triple-start mating threads, high ampacity contacts, upgraded material and finish

choices and improved EMI protection. PowerTrip™ connector is ideal for power distribution units, hybrid electric drives, motors, and other high current applications. The louverband socket contact (plug side) and enhanced durability pin contacts (hermetic receptacle side) deliver low resistance and higher ampacity.

Quick Selection Guide		
Part Number	Description	Page
	Series 970 PowerTrip™ Hermetic Connectors Introduction	M-2
	Glenair Hermetic Connector Products Special Leak Rate Mod Code	M-5
<a href="#">970-007</a>	Jam Nut Mount PowerTrip™ Bulkhead Feedthrough Receptacle How to Order	M-6
<a href="#">970-012</a>	Square Flange Mount PowerTrip™ Bulkhead Feedthrough Receptacle How to Order	M-8



## Series 970 PowerTrip™ Connectors: Superior Contacts, Mating Interface, and Backshell Attachment than Standard MS Type Power Connectors

The Series 970 connector is a high ampacity, harsh environment connector capable of meeting the demanding requirements of modern defense and aerospace systems.

Series 970 PowerTrip™ hermetic receptacles feature 316L stainless steel shells and compression glass insulators. Solder cup contacts are nickel-iron alloy and are non-removable. Coupling threads are triple-start ACME type. Contacts are silver plated high conductivity copper alloy, or choose gold-plated contacts. Fluorosilicone rubber face seal on pin connector. Stainless steel shells are passivated, or choose nickel plating for improved shell-to-shell conductivity and EMI protection. Hermeticity is  $1 \times 10^{-7}$  cc/sec maximum helium leak rate with one atmosphere pressure differential.



- *Fast, easy connector mating with triple-start ACME thread. 360° turn for full mating*
- *5 polarizing keys*
- *Reduced size and weight*
- *Louverband sockets for improved ampacity and longer life*
- *High conductivity copper alloy contacts*
- *Crimp, rear release contact system*
- *Splined backshell interface for improved EMI protection*
- *Ratcheting coupling nut for secure mating*
- *-65° C to +200° C*
- *Size 8, 4 and 1/0 contact sizes*

- **Compression Glass Seal**
- **$1 \times 10^{-7}$  cc/sec He leak rate**
- **Both Pin and Socket Versions**
- **Stainless Steel Shell**

### PRODUCT FACTS

2000 VAC Sea Level DWV Rating
-65°C to +200°C Operating Temperature
6 Feet Water Immersion, 48 Hours
65 dB min. Attenuation, up to 10GHz
2000 Cycles Mating Durability
MIL-S 901 Grade A High-Impact Shock
43 g Random Vibration

M

**Series 970  
PowerTrip™ Hermetic Connectors  
Introduction**



**Louverband Contacts**

High ampacity contacts with up to 44 points of contact for improved wear and lower voltage drop.

**Triple-Start Coupling**

Rugged ACME threads resist cross-threading and allow fast mating.

**Ratchet Mechanism**

Ratcheting anti-decoupling mechanism prevents coupling ring backoff when subjected to vibration.



*Louverband Contact*

SPECIFICATIONS	
Current Rating	Up to 225 A.
Dielectric Withstanding Voltage	2000 VAC
Insulation Resistance	5000 megohms minimum
Operating Temperature	-65° C. to +200° C.
Shock	300 g.
Vibration	37 g.
Shielding Effectiveness	65 dB minimum from 1GHz to 10GHz.
Durability	2000 mating cycles

MATERIALS AND FINISHES	
Shells, Jam Nuts	Aluminum alloy, stainless steel or marine bronze
Contacts	High conductivity copper alloy, gold or silver-plated
Insulators	Glass-reinforced epoxy
Contact Retention Clip	Beryllium copper alloy
Seal, O-rings, Grommet	Fluorosilicone rubber
Spring	Nickel-plated beryllium copper

## About LouverBand Contacts

LouverBand contacts outperform conventional contacts in the areas of durability (2000 cycles), lower mating force, and resistance.

LouverBand socket contacts consist of two parts: a copper alloy contact body (Fig. 1) and a beryllium copper band (Fig. 2). The spring is seated into the contact body (fig. 3). LouverBand contacts offer significant advantages over other contact designs. Each louver functions as an independent leaf spring. The multiple louvers in each spring distribute current more evenly, lowering the voltage drop compared to conventional contacts. A multi-spring louverband contact also reduces hotspots. Conventional contacts, such as the split-tine contact shown in (figure 4), are known to have relatively few points of contact at the microscopic level.

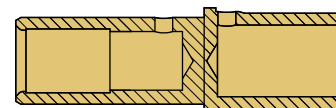

**Figure 1**  
Socket Contact Body

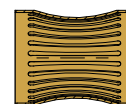

**Figure 2**  
LouverBand Spring

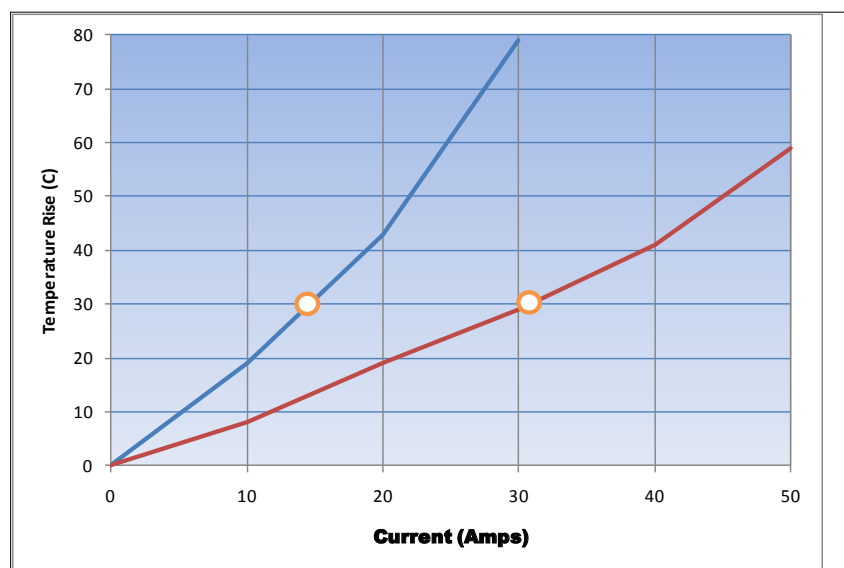

**Figure 3**  
Assembled Contact



**Figure 4**  
Split-tine Contact on the Left, LouverBand Contact on the Right

Connector current ratings are usually determined by establishing the equilibrium current resulting in a 30° C temperature rise (T-rise) above ambient. Louverband contacts typically exhibit much higher current ratings than conventional split-tine contacts. However, this higher current rating can exceed the de-rated current-carrying capacity of the wire. So why not use a conventional contact as long as the contact current rating exceeds the amount of current in the circuit? Louverband contacts are much less susceptible to damage from superheating caused by momentary current overloads. AC induction motors can cause transient currents ten times greater than the steady state current. These transient currents have a duration of only a few milliseconds. Contacts with relatively few points of contact are susceptible to melting when exposed to transient currents. The contact interface becomes welded, and de-mating the connectors breaks the weld, damaging the interface and eventually leading to high resistance, corrosion and even catastrophic failure.

### What is outgassing?

Plastic and rubber materials give off gaseous molecules. For example, the smell inside a new car is caused by polymer outgassing. Heat and vacuum increase the rate of diffusion. In a spacecraft the gases coming off polymers can contaminate optical surfaces and instruments. The result is degraded performance.

### How is outgassing measured?

The space industry has adopted a standardized test procedure, **ASTM E 595**, to evaluate out-gassing properties of polymers. Small samples of material are heated to 125° C. at a vacuum of 5 X 10<sup>-5</sup> torr for 24 hours. Then the sample is weighed to calculate the **Total Mass Loss** (TML). The TML cannot exceed 1.00% of the total initial mass. During the test, outgassed matter condenses on a cooled collector plate. The quantity of outgassed matter is calculated to determine the **Collected Volatile Condensable Material** (CVCM). The CVCM cannot exceed 0.10% of the original specimen mass.

### What is NASA screening?

NASA specification EEE-INST-002 provides instructions on selecting, screening and qualifying parts for use on NASA GSFC space flight projects.

### What screening level is required?

NASA defines three levels of screening: level 1 for highest reliability, level 2 for high reliability, and level 3 for standard reliability. Level 3 equates to standard lot acceptance inspection. Levels 1 and 2 call for additional testing.

## HOW TO ORDER SPACE GRADE CONNECTORS

### Step 1: Find a Standard Part Number

Electroless nickel plated shells are preferred for space flight. Cadmium plating is prohibited.

### Step 2: Select a NASA Screening Level

The term "Screening Level" refers to the final inspection procedure.

**Level 1** for mission-critical highest reliability

**Level 2** for high reliability

**Level 3** for standard reliability

### Step 3: Choose Outgassing Processing

A detailed explanation of outgassing is on the following pages. The fluorosilicone rubber seals commonly used on aerospace-grade connectors such as MIL-DTL-38999 and Series 79 connectors, along with certain bonding agents and inks, do not meet NASA outgassing requirements unless the connector is specially processed. Glenair outgassing tests have shown oven baking or thermal vacuum outgassing processing are sufficient to reduce outgassing levels to NASA standards. Oven baking is more economical than thermal vacuum outgassing.

### Step 4: Select the Mod 429 Code that Matches the Desired Level of Screening and Outgassing

Use the following table to choose the right modification code. Add the mod code to the connector part number. Example: 790-024PC-13ML-**429C**

M

## NASA SCREENING LEVELS AND MODIFICATION CODES

NASA Screening Level	Special Screening Only	Special Screening Plus Outgassing Processing	
		8 Hour Oven Bake 400° F.	Thermal Vacuum Outgassing 24 hrs. 125° C.
Level 1 Highest Reliability	Mod 429B	Mod 429J	Mod 429C
Level 2 High Reliability	Mod 429	Mod 429K	Mod 429A
Level 3 Standard Reliability	(Use standard part number)	Mod 186	Mod 186M



**970-007**  
**PowerTrip™ Hermetic Bulkhead Feedthrough**  
**Receptacle with Jam Nut Mounting**  
**How to Order Information**

**Series 970 Hermetic Feed-Thru Bulkhead**



Series 970 PowerTrip™ hermetic feed-thru bulkhead receptacles have pin contacts on one side and socket contacts on the other side. Attach mating plug connectors to both sides. Compression glass hermetic seal. 100% tested to meet helium leak rate of  $1 \times 10^{-7}$  cc/second at 15 psi pressure differential. Pin contact end is iron alloy, socket end is copper alloy with beryllium copper louverband spring. Coupling threads are triple-start ACME type. Contacts are factory-installed and are non-removable. Standard contacts are silver plated, or choose gold-plated contacts for improved corrosion protection in space or petrochemical environments. Fluorosilicone O-ring and face seal provide water resistant sealing. Jam nut rear panel mounting, for panel thicknesses from 1/16 -inch (1.58mm) to 1/2 inch (12.7mm).

**HOW TO ORDER**

**Sample Part Number**

970-007	Z1	24-5	P	1	-1																																																																																																																																			
Series	Shell Material and Finish	Shell Size - Insert Arrangement	Contact Type	Contact Plating	Key Position																																																																																																																																			
<b>970-007</b> Series 970 Feed-Thru Bulkhead Receptacle, Jam Nut Mounting	<b>Stainless Steel Shell</b>  <b>Z1</b> Passivated SST  <b>ZL</b> Electrodeposited Nickel over SST	<table border="1"> <thead> <tr> <th rowspan="2">Contact Arr.</th> <th colspan="5">Contact Size and Qty</th> </tr> <tr> <th>#16</th> <th>#12</th> <th>#8</th> <th>#4</th> <th>#1/0</th> </tr> </thead> <tbody> <tr><td>18-2</td><td></td><td></td><td>2</td><td></td><td></td></tr> <tr><td>18-4</td><td></td><td>2</td><td>2</td><td></td><td></td></tr> <tr><td>20-3</td><td></td><td></td><td>3</td><td></td><td></td></tr> <tr><td>20-5</td><td></td><td>2</td><td>3</td><td></td><td></td></tr> <tr><td>20-7</td><td>4</td><td></td><td>3</td><td></td><td></td></tr> <tr><td>20-4</td><td></td><td></td><td>4</td><td></td><td></td></tr> <tr><td>24-5</td><td></td><td></td><td>5</td><td></td><td></td></tr> <tr><td>24-2</td><td></td><td></td><td></td><td>2</td><td></td></tr> <tr><td>24-6</td><td></td><td>4</td><td></td><td>2</td><td></td></tr> <tr><td>24-3</td><td></td><td></td><td></td><td>3</td><td></td></tr> <tr><td>24-A6</td><td></td><td>3</td><td></td><td>3</td><td></td></tr> <tr><td>28-4</td><td></td><td></td><td></td><td>4</td><td></td></tr> <tr><td>28-9</td><td>5</td><td></td><td></td><td>4</td><td></td></tr> <tr><td>32-5</td><td></td><td></td><td></td><td>5</td><td></td></tr> <tr><td>32-2</td><td></td><td></td><td></td><td></td><td>2</td></tr> <tr><td>32-4</td><td></td><td></td><td></td><td>2</td><td>2</td></tr> <tr><td>32-3</td><td></td><td></td><td></td><td></td><td>3</td></tr> <tr><td>32-6</td><td></td><td>3</td><td></td><td></td><td>3</td></tr> <tr><td>36-4</td><td></td><td></td><td></td><td></td><td>4</td></tr> <tr><td>40-5</td><td></td><td></td><td></td><td></td><td>5</td></tr> </tbody> </table>	Contact Arr.	Contact Size and Qty					#16	#12	#8	#4	#1/0	18-2			2			18-4		2	2			20-3			3			20-5		2	3			20-7	4		3			20-4			4			24-5			5			24-2				2		24-6		4		2		24-3				3		24-A6		3		3		28-4				4		28-9	5			4		32-5				5		32-2					2	32-4				2	2	32-3					3	32-6		3			3	36-4					4	40-5					5	<p><b>P</b> Pin Contacts on Jam Nut Side</p> <p><b>S</b> Socket Contacts on Jam Nut Side</p>	<p><b>1</b> Silver Plated Contacts (Size 8, 4, 0 only)</p> <p><b>2</b> Gold Plated Contacts</p>	<p><b>-1</b> Position 1</p> <p><b>-2</b> Position 2</p> <p><b>-3</b> Position 3</p> <p><b>-4</b> Position 4</p> <p><b>-5</b> Position 5</p> <p><b>-6</b> Position 6</p>
		Contact Arr.		Contact Size and Qty																																																																																																																																				
			#16	#12	#8	#4	#1/0																																																																																																																																	
		18-2			2																																																																																																																																			
		18-4		2	2																																																																																																																																			
		20-3			3																																																																																																																																			
		20-5		2	3																																																																																																																																			
		20-7	4		3																																																																																																																																			
		20-4			4																																																																																																																																			
		24-5			5																																																																																																																																			
		24-2				2																																																																																																																																		
		24-6		4		2																																																																																																																																		
		24-3				3																																																																																																																																		
		24-A6		3		3																																																																																																																																		
		28-4				4																																																																																																																																		
		28-9	5			4																																																																																																																																		
		32-5				5																																																																																																																																		
		32-2					2																																																																																																																																	
32-4				2	2																																																																																																																																			
32-3					3																																																																																																																																			
32-6		3			3																																																																																																																																			
36-4					4																																																																																																																																			
40-5					5																																																																																																																																			

M

**970-007**  
**PowerTrip™ Hermetic Bulkhead Feedthrough**  
**Receptacle with Jam Nut Mounting**  
**Dimensions**



Series 970  
 PowerTrip™

**970-007 Feed-Thru Receptacle Connector Dimensions**

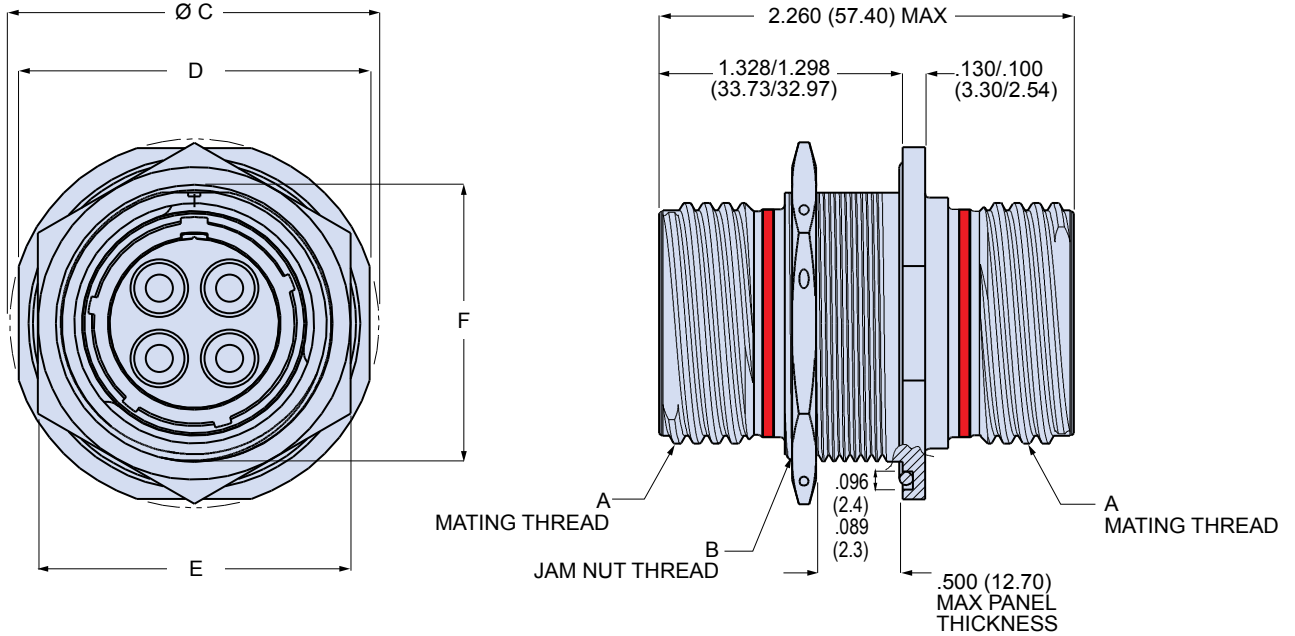

DIMENSIONS										
Shell Size	A Mating Thd.	B Jam Nut Thd.	Ø C		D		E		F	
			In.	mm.	In.	mm.	In.	mm.	In.	mm.
18	1.125-.1P-.3L-TS-2A	1.250-18 UNEF-2A	1.733	44.02	1.639	41.63	1.438	36.53	1.212	31.06
20	1.250-.1P-.3L-TS-2A	1.4375-18 UNEF-2A	1.921	48.79	1.827	46.41	1.625	41.28	1.399	35.81
24	1.500-.1P-.3L-TS-2A	1.625-18 UNEF-2A	2.108	53.54	2.014	51.16	1.822	46.28	1.587	43.76
28	1.750-.1P-.3L-TS-2A	1.9375-16 UN-2A	2.425	61.60	2.327	59.11	2.188	55.58	1.899	48.51
32	2.000-.1P-.3L-TS-2A	2.125-16 UN-2A	2.607	66.24	2.513	63.86	2.375	60.33	2.084	53.00
36	2.250-.1P-.3L-TS-2A	2.375-16 UN-2A	2.857	72.57	2.763	70.18	2.625	66.68	2.323	59.00
40	2.500-.1P-.3L-TS-2A	2.875-16 UN-2A	3.107	78.92	3.013	76.53	2.875	73.03	2.548	64.72

**M**

KEY POSITIONS				
Position	A°	B°	C°	D°
1	80	142	196	293
2	135	170	200	310
3	49	169	200	244
4	66	140	200	257
5	62	145	180	280
6	79	153	197	272

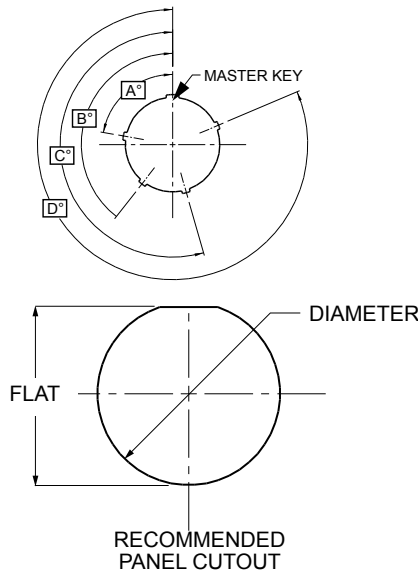

Shell Size	PANEL CUTOUT			
	Diameter		Flat	
	In.	mm.	In.	mm.
	-.000 +.010	-.00 +.25	-.000 +.010	-.00 +.25
18	1.254	31.85	1.217	30.91
20	1.441	36.60	1.404	35.66
24	1.629	41.38	1.592	40.64
28	1.941	49.30	1.904	48.36
32	2.129	54.08	2.092	53.14
36	2.379	60.43	2.328	59.13
40	2.629	66.78	2.553	64.85



## 970-012 Hermetic Receptacles



Series 970 PowerTrip™ hermetic receptacles feature 316L stainless steel shells and compression glass insulators. Solder cup contacts are nickel-iron alloy and are non-removable. Socket contacts have copper alloy louverband spring for multiple points of electrical contact. Coupling heads are triple-start ACME type. Contacts are silver plated high conductivity copper alloy, or choose gold-plated contacts for improved corrosion protection in space or petrochemical environments. Fluorosilicone rubber face seal on pin connector. Stainless steel shells are passivated, or choose nickel plating for improved shell-to-shell conductivity and EMI protection. Hermeticity is  $1 \times 10^{-7}$  cc/sec maximum helium leak rate with one atmosphere pressure differential.

### HOW TO ORDER

#### Sample Part Number

970-012	Z1	32-5	P1	N	-1																																																																																																																																			
Series	Shell Material and Finish	Shell Size - Insert Arrangement	Contact Type and Plating	Mounting Hole Option	Key Position																																																																																																																																			
<b>970-012</b> Series 970 Receptacle, Square Flange Panel Mounting	<b>Stainless Steel Shell</b>  <b>Z1</b> Passivated SST  <b>ZL</b> Electrodeposited Nickel over SST	<table border="1"> <thead> <tr> <th rowspan="2">Contact Arr.</th> <th colspan="5">Contact Size and Qty</th> </tr> <tr> <th>#16</th> <th>#12</th> <th>#8</th> <th>#4</th> <th>#1/0</th> </tr> </thead> <tbody> <tr><td>18-2</td><td></td><td></td><td>2</td><td></td><td></td></tr> <tr><td>18-4</td><td></td><td>2</td><td>2</td><td></td><td></td></tr> <tr><td>20-3</td><td></td><td></td><td>3</td><td></td><td></td></tr> <tr><td>20-4</td><td></td><td></td><td>4</td><td></td><td></td></tr> <tr><td>20-5</td><td></td><td>2</td><td>3</td><td></td><td></td></tr> <tr><td>20-7</td><td>4</td><td></td><td>3</td><td></td><td></td></tr> <tr><td>24-2</td><td></td><td></td><td></td><td>2</td><td></td></tr> <tr><td>24-3</td><td></td><td></td><td></td><td>3</td><td></td></tr> <tr><td>24-5</td><td></td><td></td><td>5</td><td></td><td></td></tr> <tr><td>24-6</td><td></td><td>4</td><td></td><td>2</td><td></td></tr> <tr><td>24-A6</td><td></td><td>3</td><td></td><td>3</td><td></td></tr> <tr><td>28-4</td><td></td><td></td><td></td><td>4</td><td></td></tr> <tr><td>28-9</td><td>5</td><td></td><td></td><td>4</td><td></td></tr> <tr><td>32-2</td><td></td><td></td><td></td><td></td><td>2</td></tr> <tr><td>32-3</td><td></td><td></td><td></td><td></td><td>3</td></tr> <tr><td>32-4</td><td></td><td></td><td></td><td>2</td><td>2</td></tr> <tr><td>32-5</td><td></td><td></td><td></td><td>5</td><td></td></tr> <tr><td>32-6</td><td></td><td>3</td><td></td><td></td><td>3</td></tr> <tr><td>36-4</td><td></td><td></td><td></td><td></td><td>4</td></tr> <tr><td>40-5</td><td></td><td></td><td></td><td></td><td>5</td></tr> </tbody> </table>	Contact Arr.	Contact Size and Qty					#16	#12	#8	#4	#1/0	18-2			2			18-4		2	2			20-3			3			20-4			4			20-5		2	3			20-7	4		3			24-2				2		24-3				3		24-5			5			24-6		4		2		24-A6		3		3		28-4				4		28-9	5			4		32-2					2	32-3					3	32-4				2	2	32-5				5		32-6		3			3	36-4					4	40-5					5	<b>P1</b> Pin Contacts, Silver Plating  <b>P2</b> Pin Contacts, Gold Plating  <b>S1</b> Socket Contacts, Silver Plating  <b>S2</b> Socket Contacts, Gold Plating	<b>N</b> Thru-Hole	<b>-1</b> Position 1  <b>-2</b> Position 2  <b>-3</b> Position 3  <b>-4</b> Position 4  <b>-5</b> Position 5  <b>-6</b> Position 6
		Contact Arr.		Contact Size and Qty																																																																																																																																				
			#16	#12	#8	#4	#1/0																																																																																																																																	
		18-2			2																																																																																																																																			
		18-4		2	2																																																																																																																																			
		20-3			3																																																																																																																																			
		20-4			4																																																																																																																																			
		20-5		2	3																																																																																																																																			
		20-7	4		3																																																																																																																																			
		24-2				2																																																																																																																																		
		24-3				3																																																																																																																																		
		24-5			5																																																																																																																																			
		24-6		4		2																																																																																																																																		
		24-A6		3		3																																																																																																																																		
		28-4				4																																																																																																																																		
		28-9	5			4																																																																																																																																		
		32-2					2																																																																																																																																	
32-3					3																																																																																																																																			
32-4				2	2																																																																																																																																			
32-5				5																																																																																																																																				
32-6		3			3																																																																																																																																			
36-4					4																																																																																																																																			
40-5					5																																																																																																																																			



**970-012**  
**PowerTrip™ Hermetic Bulkhead Feedthrough**  
**Receptacle with Square Flange Mounting**



Series 970  
 PowerTrip™

**970-007 Feed-Thru Receptacle Connector Dimensions**

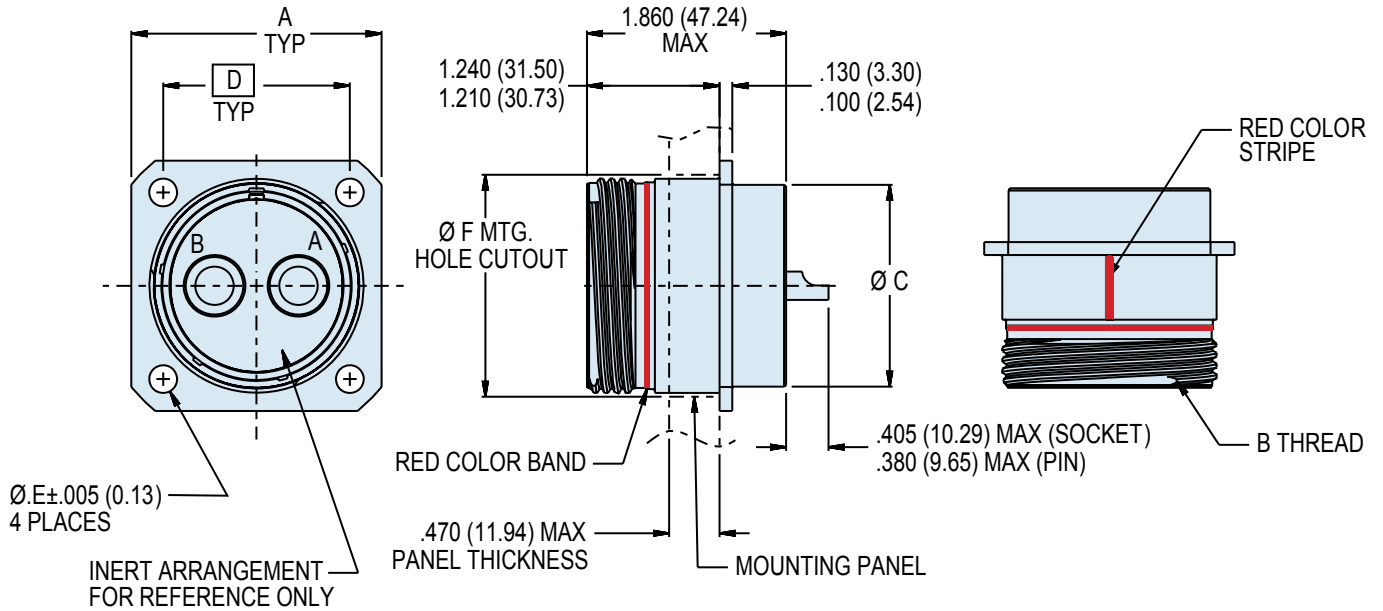

Shell Size	DIMENSIONS										
	Ø A		B Mating Thd.	Ø C		D BSC		Ø E Thru		Ø F Mtg. Hole	
	In.	mm.		In.	mm.	In.	mm.	In.	mm.	In.	mm.
18	1.383	35.13	1.125-.1P-.3L-TS-2A	.972	24.69	1.015	25.78	.146	3.70	1.187	30.15
20	1.508	38.30	1.250-.1P-.3L-TS-2A	1.116	28.35	1.140	28.96			1.374	34.90
24	1.718	43.64	1.500-.1P-.3L-TS-2A	1.300	33.02	1.281	32.54			1.562	39.67
28	2.138	54.31	1.750-.1P-.3L-TS-2A	1.604	40.74	1.568	39.83	.170	4.30	1.874	47.60
32	2.328	59.13	2.000-.1P-.3L-TS-2A	1.875	47.63	1.734	44.04			2.062	52.37
36	2.578	65.48	2.250-.1P-.3L-TS-2A	2.093	53.16	1.984	50.39			2.302	58.47
40	2.828	71.83	2.500-.1P-.3L-TS-2A	2.310	58.67	2.234	56.74	2.562	65.07		

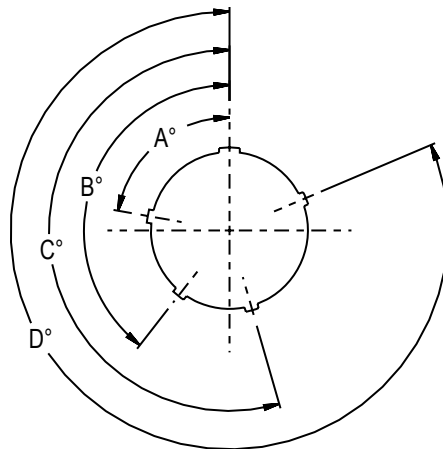

KEY POSITIONS				
Position	A°	B°	C°	D°
1	80	142	196	293
2	135	170	200	310
3	49	169	200	244
4	66	140	200	257
5	62	145	180	280
6	79	153	197	272

SPECIAL  
CONNECTORS

# GLENAIR SPECIAL

*Hermetic Connectors With Durable  
Glass-to-Metal Sealing*



Glenair excels in the rapid prototyping and development of custom hermetic connectors from initial concept to finished parts, our factory is fully self-sufficient and can produce highly reliable, rugged interconnects machined from stainless steel, Inconel®, or kovar®. Our expertise extends to the design of high density interconnects to resolve gas, moisture, and particle ingress problems. And most importantly, at Glenair we are happy to consider your limited quantity and prototype requirements. Unlike other manufacturers, Glenair is well positioned to service both low-quantity custom orders as well as high volume production requirements. Basic mounting configurations, a weld-mount or O-Ring mount design may be customized for unique application requirements.



Glenair, Inc.  
1211 Air Way  
Glendale, CA  
91201-2497  
818-247-6000  
sales@glenair.com  
www.glenair.com



## Special Hermetic Connectors

Sometimes a standard part just won't do. For these situations Glenair welcomes your custom requirements. Whatever the need, we can propose a solution and back it up with rapid design and prototyping. Glenair special hermetic connectors are made from the same passivated

stainless steel or ferrous steel shells, with glass insulators fused to the connector shell, and contacts meeting a leak rate of  $1 \times 10^{-7}$  cc/Helium per second. Innovative designs to meet every need are available from Glenair and, as always, **no minimums** are required.

Quick Selection Guide		
Part Number	Description	Page
<a href="#">237-263</a>	Special Micro Circular Quick Disconnect Receptacle, Rear Panel Jam Nut Mount	N-2
<a href="#">2570-1290</a>	Hermetic Single-Pin Feedthrough - Hi Temp, Hi Pressure	N-4



**237-263**  
**Special Micro Circular Quick Disconnect Receptacle**  
 Hermetic • Rear panel Jam Nut Mount, Socket PC Tail or Solder Cup

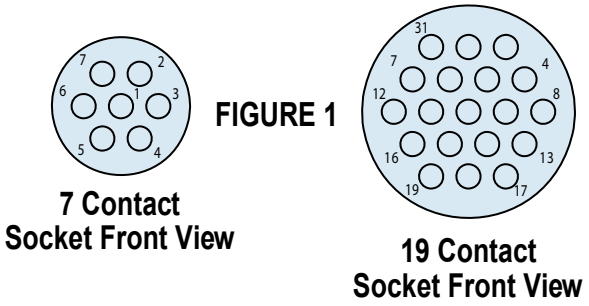
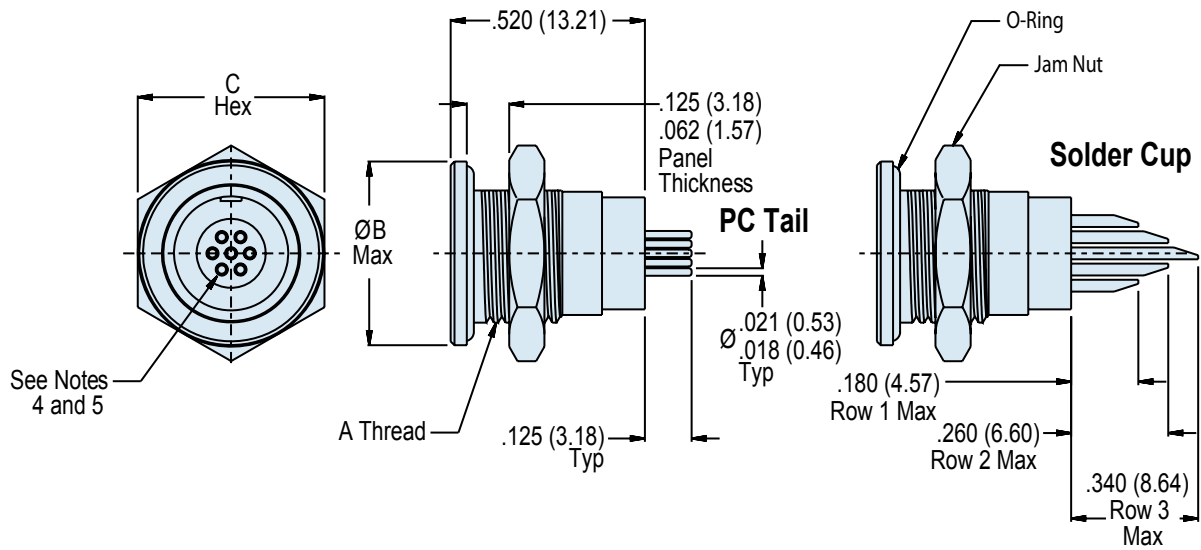
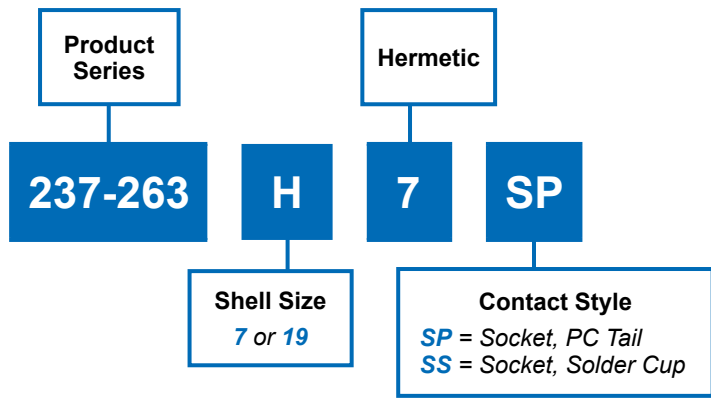
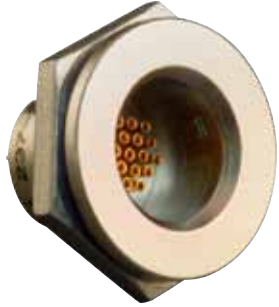

\* Additional shell materials available, including titanium and Inconel®. Consult factory for ordering information.  
 Dimensions in Inches (millimeters) are subject to change without notice.

237-263

Special Micro Circular Quick Disconnect Receptacle  
Hermetic • Rear panel Jam Nut Mount, PC Tail or Solder Cup



Special Connectors

TABLE I: CONNECTOR DIMENSIONS					
Shell Size	A Thread Class 2A	B Dia	C Hex	D Flat	E Dia ± .005 (0.13)
7	.3750-32 UNEF	.565 (14.35)	.565 (14.35)	.360 (9.14) .357 (9.07)	.380 (11.1)
19	.5000-28 UNEF	.735 (18.67)	.735 (18.67)	.485 (12.32) .483 (12.27)	.505 (12.7)

HERMETIC LEAK RATE MOD CODES	
Designator	Required Leak Rate
-585A	1 x 10 <sup>-10</sup> cc Helium per second
-585B	1 x 10 <sup>-9</sup> cc Helium per second
-585C	1 x 10 <sup>-8</sup> cc Helium per second

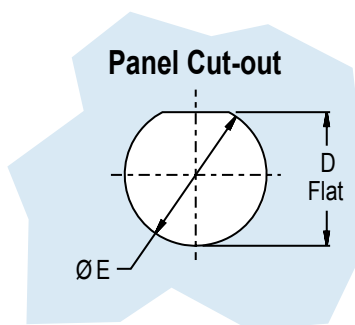

N

APPLICATION NOTES	
1. Material/Finish: Shell, Jam Nut - Stainless steel/Passivated. Insulators - Full glass/N.A. O-Ring - Fluorosilicone/N.A. Contacts - Iron-nickel alloy/Gold plate.	4. Insert arrangement is in accordance with Figure One.
2. Assembly is identified with manufacturer's name, cage code, part number and date code, space permitting.	5. Insert arrangement is shown for reference only.
3. Glenair 237-263 receptacle connector is designed to mate with Glenair quick disconnect micro circular plug, part number 257-985 having the same shell size and insert arrangement.	6. Performance: Hermeticity - <1X10 <sup>-6</sup> SccHe/sec @ 1 atmosphere differential. D.W.V. - 150 VAC at sea level. I.R. - 5000 MegaOhms minimum.
	7. Metric dimensions (mm) are in parentheses.

Dimensions in Inches (millimeters) are subject to change without notice.

# 2570-1290

## Single Pin High Temperature High Pressure (HTHP) Hermetic • Single-Pin Feedthrough



Product Series

2570-1290

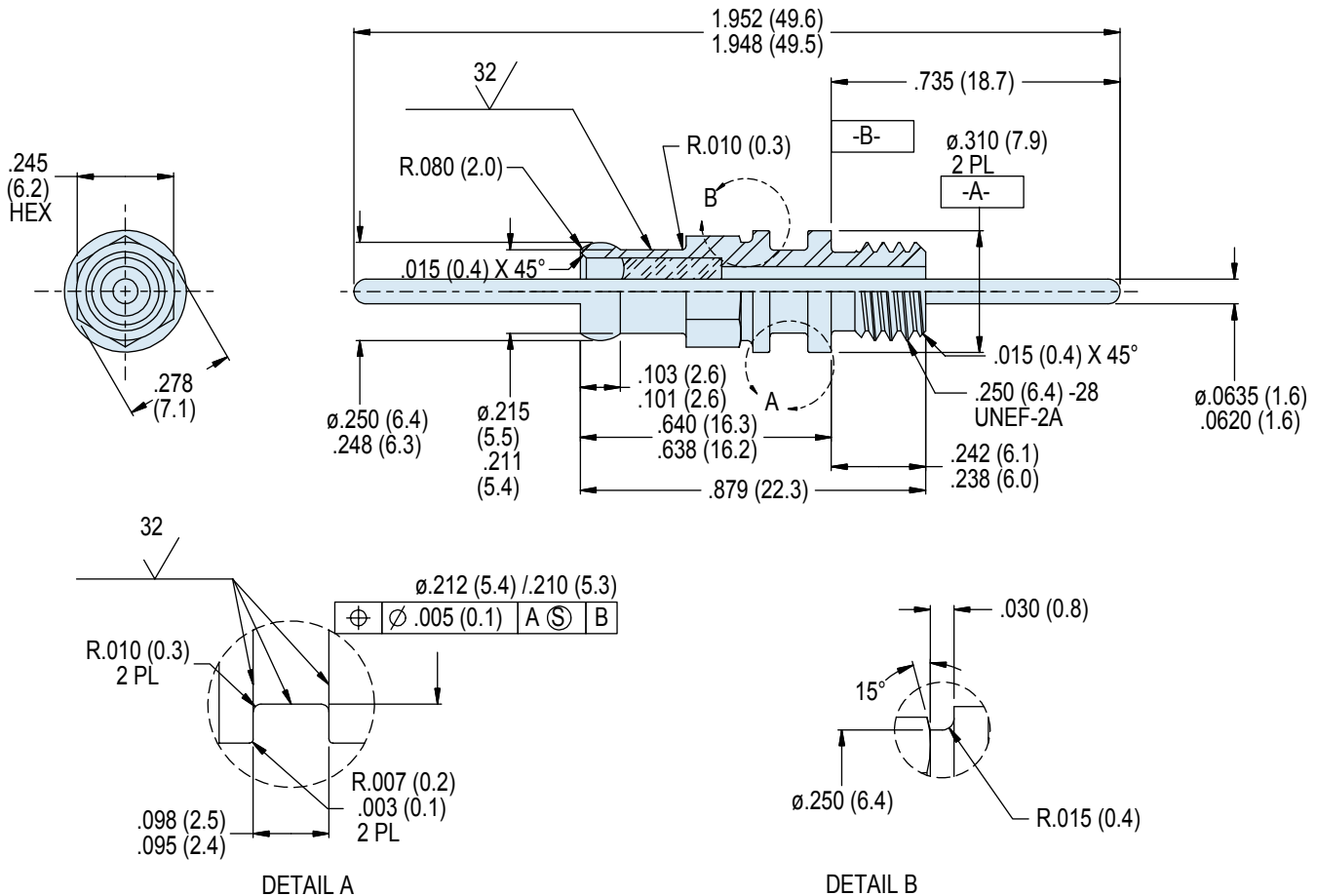

## APPLICATION NOTES

- Material / Finish:  
Body - Inconel® X-750 / none  
Pin - Inconel® X-750 / gold plate .00005 min. thick  
Insulator - vitreous glass/n/a
- Performance Tests:  
Hermeticity -  $<1 \times 10^{-8}$  sccHe/sec @ 1 ATM diff  
D.W.V. - 1000 VDC pin to shell without breakdown  
I.R. - 5000 megohms min @ 500 VDC (ambient)  
500 megohms min @ 500 VDC (300° F)

Dimensions in Inches (millimeters) are subject to change without notice.



# Hermetic Connectors Product Index



MIL-DTL-38999 Series I, II, III and IV QPL Hermetic Connectors		
Part number	Description	Page
	MIL-DTL-38999 Series I, II, III and IV Hermetic Class Insert Arrangements	B-2
	MIL-DTL-38999 Series I, II, III and IV Hermetic Class Layouts and Pin Counts	B-4
	MIL-DTL-38999 Hermetic Class Material Specifications and Finishes	B-5
	MIL-DTL-38999 Connector Performance Specifications	B-6
	MIL-DTL-38999 Contact Performance Specifications	B-9
	MIL-DTL-38999 Series I – IV Alternate Keyway Positions	B-10
	Recommended Torque Values	B-13
	MIL-DTL-38999 Hermetic Connectors and Environmental Mates	B-14
<b>MS27469 / 231-100-H0</b>	Wall Mount Hermetic Receptacle, Series I	B-16 / B-17
<b>MS27470 / 231-100-H7</b>	Jam Nut Mount Hermetic Receptacle, Series I	B-18 / B-19
<b>MS27471 / 231-100-H5</b>	Solder Mount Hermetic Receptacle, Series I	B-20 / B-21
<b>231-103-H7</b>	Jam Nut Mount Hermetic Bulkhead Feed-Thru, Series I	B-22
<b>231-103-H9</b>	Sav-Con® Jam Nut Mount Bulkhead Feed-Thru, Series I	B-24
<b>257-255</b>	Jam Nut Mount Hermetic Receptacle, Series I	B-26
<b>MS27475 / 232-100-H0</b>	Wall Mount Hermetic Receptacle, Series II	B-28 / B-29
<b>MS27476 / 232-100-H2</b>	Box Mount Hermetic Receptacle, Series II	B-30 / B-31
<b>MS27477 / 232-100-H7</b>	Jam-Nut Mount Hermetic Receptacle, Series II	B-32 / B-33
<b>MS27478 / 232-100-H5</b>	Solder Mount Hermetic Receptacle, Series II	B-34 / B-35
<b>232-103-H7</b>	Jam Nut Mount Hermetic Bulkhead Feedthrough, Series II Type	B-36
<b>237-280</b>	Special Weld-Mount Hermetic Receptacle, Series II	B-38
<b>947-120</b>	Jam Nut Mount Hermetic Bulkhead Feed-Thru, Series II	B-40
<b>947-278</b>	Jam Nut Mount Hermetic Bulkhead Feed-Thru	B-42
<b>D38999/21 / 233-100-H2</b>	Box Mount Hermetic Receptacle, Series III	B-44 / B-45
<b>D38999/23 / 233-100-H7</b>	Jam Nut Mount Hermetic Receptacle, Series III	B-46 / B-47
<b>D38999/25 / 233-100-H5</b>	Solder Mount Hermetic Receptacle, Series III	B-48 / B-49
<b>D38999/27 / 233-100-H8</b>	Weld Mount Hermetic Receptacle, Series III	B-50 / B-51
<b>233-103-H7</b>	Jam Nut Mount Hermetic Bulkhead Feed-Thru, Series III	B-52
<b>233-103-H9</b>	Jam Nut Mount Hermetic Plug/Receptacle Bulkhead Feed-Thru, Series III	B-53
<b>237-033</b>	Jam Nut Mount Hermetic with Double O-Rings, Series III	B-54
<b>237-063</b>	Special Hermetic Jam Nut Mount Receptacle, Series III	B-56
<b>237-153</b>	Hermetic Dual Flange Jam Nut Mount Receptacle, Series III	B-58
<b>257-093</b>	Jam Nut Mount Hermetic Bulkhead Feed-Thru, Series III	B-60
<b>257-121</b>	Special Jam Nut Mount Hermetic Receptacle with Accessory Threads, Series III	B-62
<b>257-215</b>	Jam Nut Mount Hermetic Bulkhead Feed-Thru w/ Crimp Removable Contacts, Series III	B-64
<b>257-216</b>	Jam Nut Mount Hermetic Bulkhead Feed-Thru w/ Crimp Removable Contacts, Series III	B-66
<b>257-288</b>	Box Mount Hermetic Bulkhead Feed-Thru w/ Crimp Removable Contacts, Series III	B-68
<b>257-333</b>	Hermetic Jam Nut Receptacle w/ Crimp Removable Contacts, Series III	B-70
<b>947-082</b>	Jam Nut Hermetic Bulkhead Feed-Thru, Series III	B-72
<b>947-115</b>	Jam Nut Hermetic Bulkhead Feed-Thru, Series III	B-73
<b>947-117</b>	Jam Nut Mount Hermetic Bulkhead Feed-Thru, Series I	B-74
<b>947-282</b>	Flange Mount Hermetic Bulkhead Feed-Thru, Series III	B-76
<b>D38999/41 / 234-100-H2</b>	Box Mount Hermetic Receptacle, Series IV	B-78 / B-79
<b>D38999/43 / 234-100-H7</b>	Jam Nut Mount Hermetic Receptacle, Series IV	B-80 / B-81
<b>D38999/45 / 234-100-H5</b>	Solder Mount Hermetic Receptacle, Series IV	B-82 / B-83
<b>D38999/48 / 234-100-H8</b>	Weld Mount Hermetic Receptacle, Series IV	B-84 / B-85





## Hermetic Connectors Product Index

Series 800 Mighty Mouse Hermetic Connectors		
Part Number	Description	Page
	Series 80 Mighty Mouse Product Selection Guide	C-2
	Series 80 Mighty Mouse Contact Arrangements	C-4
	Series 80 Mighty Mouse Straight PCB Footprints	C-9
	Series 80 Mighty Mouse Flange Gaskets 809-108	C-25
	Series 80 Mighty Mouse Recommended Torque Values	C-28
	Glenair Connector Products Special Leak Rate Mod Code	C-29
<b>800-013</b>	Series 80 How to Order Information	C-30
<b>800-013-02 and 800-013-03</b>	Square Flange Mount Connectors	C-32
<b>800-013-07</b>	Jam Nut Mount Connector	C-33
<b>801-012</b>	Series 801 How to Order Information	C-34
<b>801-012-02</b>	Square Flange Mount Connector	C-35
<b>801-012-03</b>	Solder Mount Connector	C-36
<b>801-012-07</b>	Jam Nut Mount Connector	C-37
<b>801-012-013</b>	Weld Mount Connector	C-38
<b>801-059</b>	Quick Coupling Connector with Co-Ax Pins Ordering Information	C-39
<b>801-059-02</b>	Flange Mount Quick Coupling Connector with Co-Ax Pins	C-40
<b>801-059-03</b>	Solder Mount Quick Coupling Connector with Co-Ax Pins	C-41
<b>801-059-07</b>	Jam Nut Mount Quick Coupling Connector with Co-Ax Pins	C-42
<b>802-013</b>	Series 802 Aqua Mouse Submersible Hermetic Receptacle	C-43
<b>802-013-00</b>	Front Mount Jam Nut Receptacle	C-44
<b>802-013-02</b>	Square Flange Mount Receptacle	C-45
<b>802-013-03</b>	Weld Mount Receptacle	C-46
<b>802-013-07</b>	Rear Mount Jam Nut Receptacle	C-47
<b>802-040</b>	Series 802 Aqua Mouse Connector How to Order Information	C-48
<b>802-040-00</b>	Front Panel Jam Nut Mount Connector, Coax Contacts	C-49
<b>802-040-02</b>	Front Panel Square Flange Mount Connector, Coax Contacts	C-50
<b>802-040-03</b>	Weld Mount Connector, Coax Contacts	C-51
<b>802-040-07</b>	Rear Panel Jam Nut Mount Connector, Coax Contacts	C-52
<b>803-006</b>	Series 803 How to Order Information	C-53
<b>803-006-02 and 803-006-07</b>	1/4 Turn Bayonet and Jam Nut Mount Connectors	C-54
<b>804-006</b>	Series 804 How to Order Information	C-55
<b>804-006-00</b>	Front Panel Jam Nut Mount Receptacle	C-56
<b>804-006-07</b>	Rear Panel Jam Nut Mount Receptacle	C-57
<b>805-006</b>	Series 805 How to Order Information	C-58
<b>805-006-02</b>	Square Flange Mount Connector	C-59
<b>805-006-03</b>	Solder Mount Connector	C-60
<b>805-006-07</b>	Jam Nut Mount Connector	C-61
<b>805-006-013</b>	Front Panel Weld Mount Connector	C-62
MIL-DTL-26482 Type Quick Release Bayonet Coupling Hermetic Connectors		
Part Number	Description	Page
	MIL-DTL-26482 Type Insert Arrangements	D-2
	MIL-DTL-26482 Type Alternate Key Positions	D-3
	Glenair Hermetic Connector Products Space Grade Mod Codes	D-4
	Glenair Hermetic Connector Products Special Leak Rate Mod Codes	D-5
<b>230-014</b>	Bayonet Coupling Solder Mount Receptacle MS3113 Type	D-6

# Hermetic Connectors Product Index



<a href="#">230-015</a>	Bayonet Coupling Jam Nut Receptacle MS3114 Type	D-8
<a href="#">947-303</a>	Narrow Flange Mount Bulkhead Feed-Thru MS3440 Type	D-10
<a href="#">230-035</a>	Bayonet Coupling Narrow Flange Mount Receptacle MS3112 Type	D-12
<a href="#">230-016</a>	Bayonet Coupling Narrow Flange Mount Receptacle MS3440 Type	D-14
<a href="#">230-017</a>	Bayonet Coupling Wide Flange Mount Receptacle MS3442 Type	D-16
<a href="#">230-018</a>	Bayonet Coupling Solder Flange Mount Receptacle MS3443 Type	D-18
<a href="#">230-019</a>	Quick Release Bayonet Receptacle, Single Hole Jam Nut MS3443 Type	D-20
<a href="#">230-020</a>	Bayonet Coupling Solder Mount Receptacle with Solderless Contacts MS3473 Type	D-22
<a href="#">230-021</a>	Bayonet Coupling Box Mount Receptacle with Solderless Contacts MS3477 Type	D-24
<a href="#">230-022</a>	Bayonet Coupling Jam Nut Mount Receptacle with Solderless Contacts MS3479 Type	D-26
<a href="#">230-034</a>	Bayonet Coupling Jam Nut Receptacle MS3449 Type	D-28
<a href="#">230-240</a>	MIL-DTL-26482 Series I Connector, Special Square Flange Mount, Bayonet Coupling	D-30
<a href="#">257-135</a>	Bayonet Coupling Jam Nut Mount Pin/Pin Bulkhead Feed-Thru Receptacle	D-32
<a href="#">947-292</a>	Bayonet Coupling Jam Nut Mount Bulkhead Feed-Thru Receptacle	D-34
<b>MIL-DTL-83723 Series III Type Threaded and Bayonet Coupling Hermetic Connectors</b>		
Part Number	Description	Page
	MIL-DTL-83723 Series III Type Insert Arrangements	E-2
	Glenair Hermetic Connector Products Space Grade Mod Codes	E-3
	Glenair Hermetic Connector Products Special Leak Rate Mod Code	E-4
	MIL-DTL-83723 Series III Type Insert Arrangements and Keyway Positions	E-5
<a href="#">230-023</a>	Bayonet Coupling Square Flange Receptacle with Solder Terminals 83723/79 Type	E-6
<a href="#">230-024</a>	Bayonet Coupling Solder Flange Receptacle with Solder Terminals 83723/80 Type	E-8
<a href="#">230-025</a>	Bayonet Coupling Jam Nut Receptacle with Solder Terminals 83723/81 Type	E-10
<a href="#">230-026</a>	Bayonet Coupling Solder Flange Receptacle with Straight Pin Contacts 83723/93 Type	E-12
<a href="#">230-027</a>	Bayonet Coupling Jam Nut Receptacle with Straight Pin or PCB Contacts 83723/88 Type	E-14
<a href="#">230-028</a>	Threaded Coupling Square Flange Receptacle with Solder Terminals 83723/89 Type	E-16
<a href="#">230-029</a>	Threaded Coupling Jam Nut Receptacle with Solder Terminals 83723/90 Type	E-18
<a href="#">230-030</a>	Threaded Coupling Solder Flange Receptacle with Solder Terminals	E-20
<b>MIL-DTL-26500 Type Hermetic Connectors</b>		
Part Number	Description	Page
	MIL-DTL-26500 Type Insert Arrangements	F-2
	Glenair Hermetic Connector Products Space Grade Mod Codes	F-3
	Glenair Hermetic Connector Products Special Leak Rare Mod Code	F-4
	MIL-DTL-26500 Type Insert Arrangements and Keyway Positions	F-5
	MIL-DTL-26500 Type Materials and Finishes	F-6
	MIL-DTL-26500 Type Bayonet and Threaded Coupling and Electrical Service Data	F-7
<a href="#">230-036</a> <a href="#">MS27034H*B**</a>	MIL-DTL-26500 Type Bayonet Coupling Solder Flange Mount Receptacle	F-8
<a href="#">230-038</a> <a href="#">MS27034H*T**</a>	MIL-DTL-26500 Type Threaded Coupling Solder Flange Mount Receptacle	F-10
<a href="#">230-039</a>	MIL-DTL-26500 Type Bayonet Coupling Single Hole Mount Receptacle	F-12
<a href="#">230-040</a>	MIL-DTL-26500 Type Threaded Coupling Single Hole Mount Receptacle	F-14
<a href="#">230-041</a>	MIL-DTL-26500 Type Bayonet Coupling Square Flange Mount Receptacle	F-16
<a href="#">237-165</a>	MIL-DTL-26500 Type Threaded Coupling Square Flange Mount Receptacle	F-18
<b>MIL-DTL-5015 Type Hermetic Power and Signal Connectors</b>		
Part Number	Description	Page
	MIL-DTL-5015 Type Insert Arrangements	G-2
	MIL-DTL-5015 Type Alternate Key Positions	G-5



## Hermetic Connectors Product Index

<b>250-013</b>	Threaded Coupling Square Flange Receptacle MS3142 Type	G-6
<b>250-014</b>	Threaded Coupling Solder Mount Receptacle MS3143 Type	G-8
<b>250-015</b>	Threaded Coupling Box Mount Receptacle Connector MS3142 Type	G-10
<b>250-016</b>	Threaded Coupling Solder Mount Receptacle Connector MS3143 Type Sockets	G-12
<b>250-025</b>	Threaded Coupling Flangeless Mount Receptacle Connector MS3143 Type	G-14
<b>257-384</b>	Jam Nut Mount Receptacle Connector MS3404 Type	G-16
<b>947-042</b>	Jam Nut Mount Bulkhead Feed-Thru Connector with Pin/Socket Contacts	G-18
<b>947-056</b>	Jam Nut Mount Bulkhead Feed-Thru Connector with Pin/Pin Contacts	G-20
<b>947-259</b>	Panel Mount Bulkhead Feed-Thru Receptacle	G-22
<b>947-371</b>	Jam Nut Mount Bulkhead Feed-Thru Receptacle	G-24
<b>Series 22 Geo-Marine® High Density Severe Environment Hermetic Connectors</b>		
Part Number	Description	Page
	Series 22 Geo-Marine® Product Information	H-2
	Glenair Hermetic Connector Products Special Leak rate Mod Code	H-3
	Geo-Marine® Insert Arrangements	H-4
	Geo-Marine® Alternate Keyway Positions, Materials and Finishes	H-5
<b>220-00 and 220-10</b>	Front Mounted Jam-Nut Bulkhead Connector Receptacle	H-6
<b>220-01 and 220-11</b>	In-Line Connector Receptacle Assembly	H-8
<b>220-02 and 220-12</b>	Square Flange Mount Connector Receptacle Assembly	H-10
<b>220-03 and 220-13</b>	Solder Mount Bulkhead Connector Receptacle Assembly	H-12
<b>220-04 and 220-14</b>	Rear Mounted Jam Nut Wall Mount Connector Receptacle Assembly	H-14
<b>220-07 and 220-17</b>	Rear Mounted Jam Nut Box Mount Receptacle Assembly	H-16
<b>227-092</b>	Special Scoop-Proof Jam Nut Receptacle, Sizes -10, -12 and -14	H-18
<b>MIL-DTL-24308 D-Subminiature Hermetic Connectors</b>		
Part Number	Description	Page
	MIL-DTL-24308 Type Hermetic Connector Solder Mount Information	J-2
	Glenair Hermetic Connector Products Space Grade Mod Codes	J-3
	Glenair Hermetic Connector Products Special Leak Rate Mod Codes	J-4
	MIL-DTL-24308 Type Hermetic Connector Materials, Finishes and Specifications	J-5
	MIL-DTL-24308 Type Hermetic Connector Insert Arrangements and Panel Cut-Outs	J-6
	MIL-DTL-24308 Type Hermetic Connector Style A and Style B Dimensions	J-7
<b>280-003</b>	Glass Sealed D-Subminiature Receptacle	J-8
<b>280-006</b>	Glass Sealed D-Subminiature Receptacle	J-10
<b>280-009</b>	Pin-To-Pin D-Subminiature Feedthrough	J-12
<b>280-012</b>	Rear PCB Termination Glass Sealed D-Subminiature Connector	J-14
<b>280-013</b>	O-Ring Panel Sealing High Density D-Subminiature Connector	J-16
<b>280-014</b>	O-Ring Panel Sealing D-Subminiature Connector	J-18
<b>287-018</b>	Glass-Sealed D-Subminiature Connector with Front Mount O-Ring Seal	J-20
<b>287-035</b>	High Density Glass-Sealed D-Subminiature Connector	J-22
<b>MIL-DTL-83513 Type Micro-D Hermetic Connectors</b>		
Part Number	Description	Page
	MIL-DTL-83513 Type Micro-D Hermetic Connector Introduction	K-2
	Glenair Hermetic Connector Products Special Leak rate Mod Code	K-3
	MIL-DTL-83513 Type Micro-D Connectors General Information	K-4
	MIL-DTL-83513 Type Micro-D Design Notes and Contact Arrangements	K-5
	MIL-DTL-83513 Type Micro-D Materials and Finishes and Performance Specifications	K-6
<b>177-140H and 177-704H</b>	Solder Mount Micro-D Hermetic Connector	K-7
<b>177-705H and 177-706H</b>	Rear Panel Mount with O-Ring Micro-D Hermetic Connector	K-9

# Hermetic Connectors Product Index



<a href="#">287-080</a>	Rear Panel Mount with O-Ring Micro-D Hermetic Connector	K-12
<a href="#">177-232</a>	Front Mount Socket Shell Micro-D Hermetic Connector, Size 37	K-14
<a href="#">177-859</a>	Front Mount Socket Shell Micro-D Hermetic Connector, Sizes 9 to 21	K-15
<b>Series 79 Micro-Crimp Hermetic Connectors</b>		
Part Number	Description	Page
	Series 79 Micro-Crimp Hermetic Connectors General Information	L-2
	Series 79 Micro-Crimp Recommended Panel Cutouts	L-3
	Series 79 Micro-Crimp Contact Arrangements	L-5
	Series 79 Micro-Crimp Connectors for Space Flight	L-8
<a href="#">790-066</a>	Hermetic Rear Panel Mount Receptacle, Pin Face, Solder Cup Contacts	L-9
<a href="#">797-077</a>	Hermetic Receptacle, E-11P2 Arrangement	L-14
<a href="#">797-087</a>	Hermetic Receptacle, Pin Contacts with P.C. Tails, Size H-66 Only	L-15
<a href="#">797-204</a>	Hermetic Receptacle, Pre-Wired Pin Contacts, Shell Size G-33	L-17
<a href="#">797-216</a>	Rectangular Hermetic Receptacle Connector 9 X Coax Contacts	L-19
<b>Series 970 PowerTrip™ Hermetic Connectors</b>		
Part Number	Description	Page
	Series 970 PowerTrip™ Hermetic Connectors Introduction	M-2
	Glenair Hermetic Connector Product Space Grade Mod Codes	M-5
<a href="#">970-007</a>	Jam Nut Mount PowerTrip™ Bulkhead Feedthrough Receptacle How to Order Information	M-6
<a href="#">970-012</a>	Square Flange Mount PowerTrip™ Bulkhead Feedthrough Receptacle How to Order Information	M-8
<b>Special Hermetic Connectors</b>		
Part Number	Description	Page
<a href="#">237-263</a>	Special Micro Circular Quick Disconnect Receptacle, Rear Panel Jam Nut Mount	N-2
<a href="#">2570-1290</a>	Single Pin High Temperature High Pressure (HTHP) Hermetic -- Single Pin Feedthrough	N-4



*Out of This World*  
**INTERCONNECT  
SOLUTIONS**

**Glenair, Inc.**

1211 Air Way • Glendale, California • 91201-2497  
Telephone: 818-247-6000 • Fax: 818-500-9912 • sales@glenair.com  
[www.glenair.com](http://www.glenair.com)

**Glenair Power  
Products Group**

860 N. Main Street Extension  
Wallingford, CT  
06492

Telephone:  
203-741-1115  
Facsimile:  
203-741-0053  
sales@glenair.com

**Glenair UK Ltd**

40 Lower Oakham Way  
Oakham Business Park  
P.O. Box 37, Mansfield  
Notts, NG18 5BY England

Telephone:  
+44-1623-638100  
Facsimile:  
+44-1623-638111  
sales@glenair.co.uk

**Glenair Microway Systems**

7000 North Lawndale Avenue  
Lincolnwood, IL  
60712

Telephone:  
847-679-8833  
Facsimile:  
847-679-8849

**Glenair Nordic AB**

Gustav III : S Boulevard 46  
S - 169 27 Solna  
Sweden

Telephone:  
+46-8-50550000  
Facsimile:  
+46-8-50550001  
sales@glenair.se

**Glenair Electric GmbH**

Schaberweg 28  
D. 61348 Bad Homburg  
Germany

Telephone:  
06172 / 68 16 0  
Facsimile:  
06172 / 68 16 90  
germany@glenair.com

**Glenair Iberica**

C/ La Vega, 16  
45612 Velada  
Spain

Telephone:  
+34-925-89-29-88  
Facsimile:  
+34-925-89-29-87  
sales@glenair.es

**Glenair Italia S.p.A.**

Via Del Lavoro, 7  
40057 Quarto Inferiore –  
Granarolo dell'Emilia  
Bologna, Italy

Telephone:  
+39-051-782811  
Facsimile:  
+39-051-782259  
info@glenair.it

**Glenair France SARL**

7, Avenue Parmentier  
Immeuble Central Parc #2  
31200 Toulouse  
France

Telephone:  
+33-5-34-40-97-40  
Facsimile:  
+33-5-61-47-86-10  
sales@glenair.fr

