

Advanced Thumbscrew Hold-Down

P/N: 200-25254-102



Thumbscrew Hold-Down



P/N: 200-23558-101 Tray

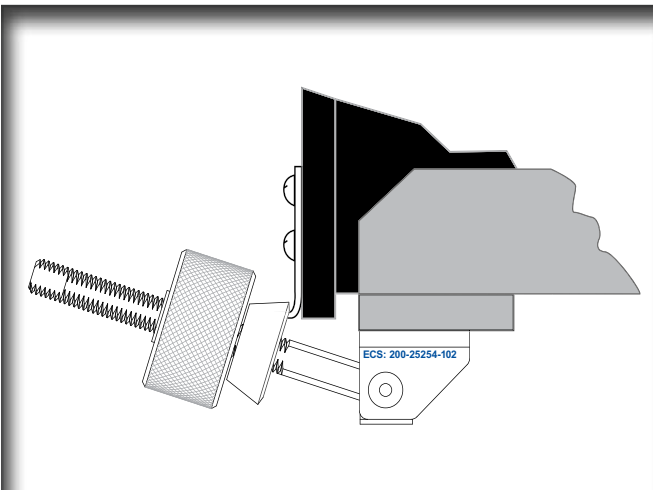

Pivot angle of Hold-Down securing LRU equipment

FEATURES & BENEFITS

Safety

- » Resists vibration and shock even when not fully engaged

Function

- » Secure ratcheting locking mechanism
- » Easy engagement and dis-engagement

CONSTRUCTION

Materials

- » Corrosion resistant steel with passivation or nickel plated components
- » Acetal/Delrin
- » RoHS Compliant

Fasteners

- » Installation via #6-32 (.138-32) UNC screws using standard tooling

SPECIFICATIONS

Conforms to

- » ASNA2168

Designed for use with equipment:

- » ARINC 404A » ARINC 704A
- » ARINC 600 » ARINC 738A-1
- » ARINC 628

Weight

- » 57g Max

Patent Pending

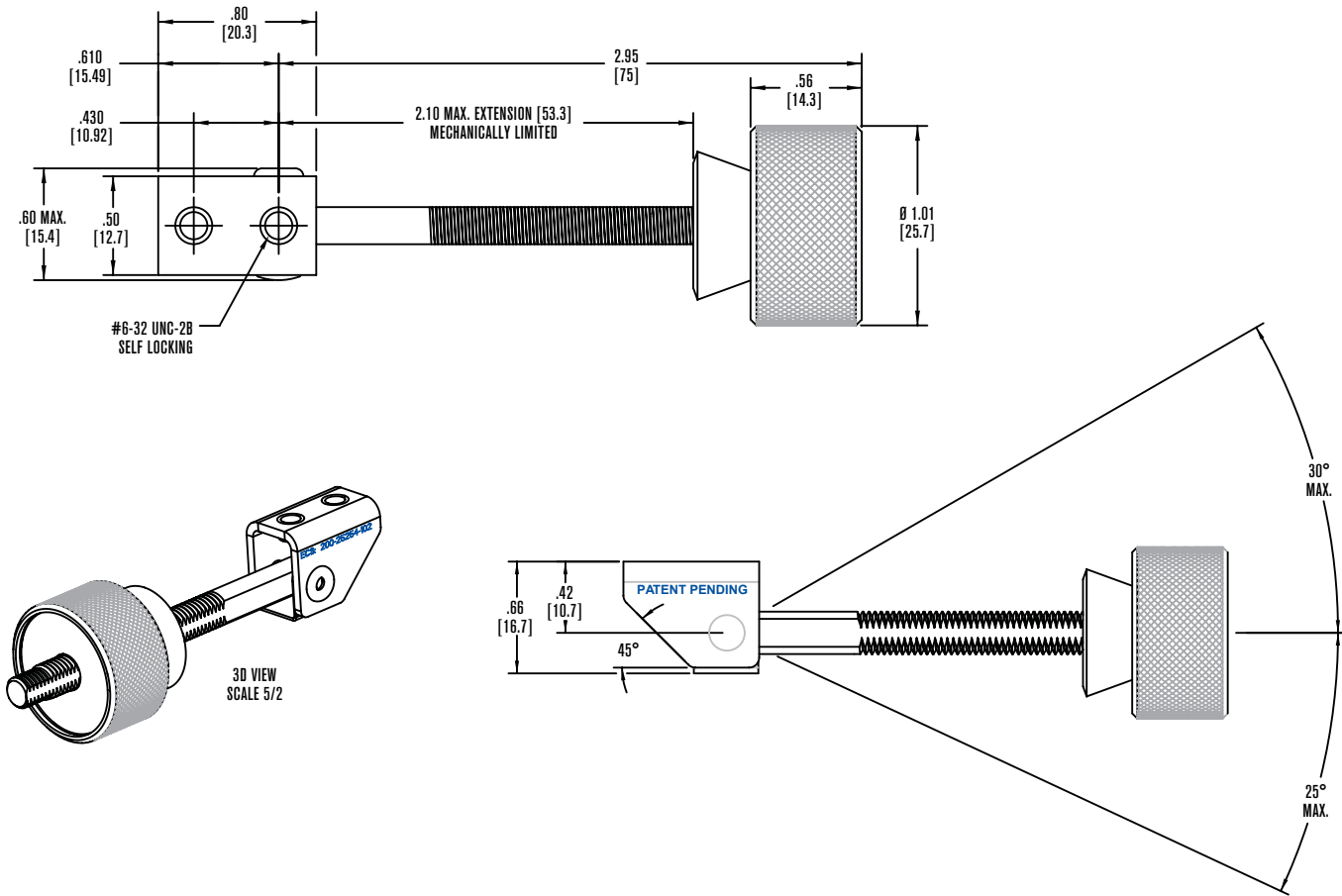

TESTED TO MEET THE FOLLOWING REQUIREMENTS

Temperature

» Cat D3 per section 4.0 of RTCA/DO-160G

Operational Shock

» 6g 11ms ½ sine shock pulse (3 shocks in all 6 directions)

Crash Safety Impulse

» 15g 11ms ½ sine shock pulse (1 shock in all 6 directions)
 » 20Gs per section 7.3.1 of RTCA/DO-160G (1 shock in all 6 directions)

Crash Safety Sustained

» 12g (1min all 6 directions)
 » 20Gs per section 7.3.3 of RTCA/DO-160G (3 seconds in all 6 directions)

Robust Vibration

» Sinusoidal (3 hours for each direction up to 2.5G)
 » Random Cat R, Curve B & B1 per section 8.7.2 of RTCA/DO-160G
 » BPS-C-157 section 3.6.4

Unbalance (Tire Burst)

» 36 seconds up to 10G in each direction

Max Flight Acceleration

» 6.5G up, 4.5G down, 3G other directions for 3min

Windmilling

» Sweep (9-30Hz) for 160 minutes between 4 & 5.6G, 1 sweep 9-2Hz at 3G

Mechanical Endurance

» 1,000 cycles

Flammability

» F3 Horizontal per Title 14 CFR 25.853(a), Appendix F, Part I (a)(1)(iv)

Optical Smoke Density

» Title 14 CFR 25.853(d), Appendix F, Part V
 » BSS 7238
 » AITM 2.0007 per ABD0031 (6.3) (7.3 & 7.31 & 7.3.2 Table 1)

Generation of Toxic Gasses

» BSS 7239
 » AITM 3.0005 per ABD0031 (7.4)