

HBH HYBRID HYPERBOLOID SERIES

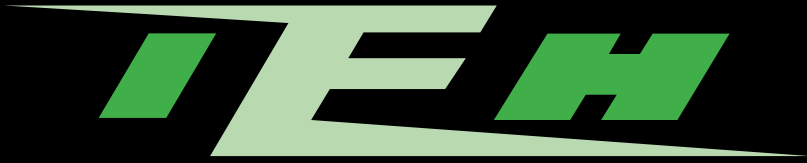

HYPERBOLOID CONNECTORS

FOR SUPERIOR PERFORMANCE IN ALL APPLICATIONS

IEH CORPORATION ISO 9001:2015

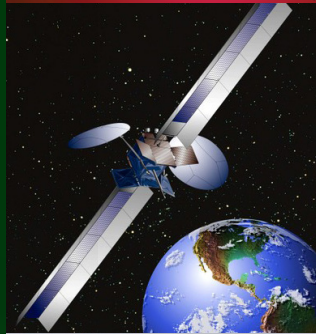
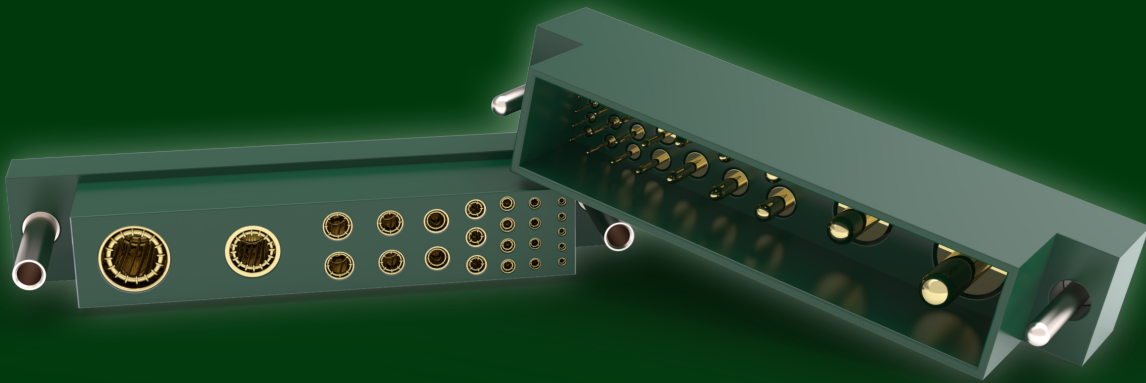
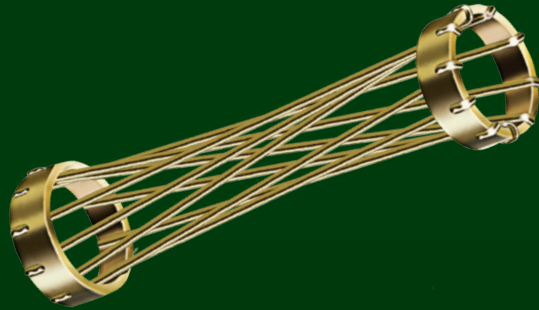

www.iehcorp.com

IEH Quality Statement

Listening to our customers and meeting their needs while
continuously improving our processes and services

CONTENTS

HBH SERIES - HYBRID CONNECTOR

PAGE

- 2 Introduction
- 3 Specifications-1
- 4 Specifications-2
- 5 Ordering Chart
- 6 Module Chart
- 7 How To Order / Build

HBH INSULATOR

- 8 Insulator - Receptacle Body
- 9 Insulator - Plug Body

HBH MODULE

- 10 Module - Signal Contacts
- 11 Module - Power Contacts, RF
- 12 Module - Spacers

HARDWARE & MOUNTING

- 13 Hardware - Receptacle
- 14 Hardware - Plug
- 15 Polarization Chart
- 16 Mounting Style
- 17 Mounting Style

TERMINATION

- 18 Receptacle, Solder Cup and Crimp
- 19 Receptacle, Solder Dip and Right Angle Solder Dip
- 20 Receptacle, Compliant
- 21 Plug, Solder Cup and Crimp
- 22 Plug, Solder Dip and Right Angle Solder Dip
- 23 Plug, Compliant

APPENDIX

- A1 Connector with Shroud

The HYPERBOLOID contact is an advanced design that satisfies performance requirements previously considered impossible. Radically different in concept, it is used in connectors having the highest standards of performance. The distinguishing feature of the HYPERBOLOID socket is the hyper-boloid-shaped sleeve formed by straight wires strung at an angle to the longitudinal axis. Viewed from the side, you see a curve defined by a series of apparent short straight line segments which are tangent lines to points along a hyperbolic curve. This geometry provides for a design which has a decreasing circumscribed circle when viewed from the entry. It begins larger than the pin acceptance diameter and is less than this same diameter at the center. When the pin is inserted into this sleeve, the wires stretch, well within elastic limits, to accommodate it. In so doing, the wires wrap themselves around the pin providing a number of continuous line contact paths. The illustration below will assist in visualization.

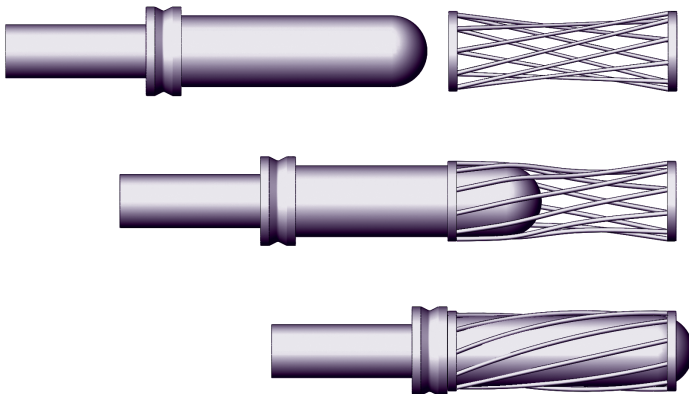

The actual physical construction of the contact involves several components. The wires are strung on an internal wire carrier (inner sleeve) which is subsequently capped or enclosed by a front outer ring (front sleeve) and rear ring which includes the termination configuration (terminal). All components to the assembly are completely finished with the specified electroplating prior to assembly. The wires are continuous process plated on reel before use. In this manner, interface finish requirements can be controlled very closely without the common problems of gradient, shadow, or other finish imperfections often appearing in alternative designs. Very often, this processing feature permits the specifier to reduce precious metal content with resultant savings. Joints are calculated interference fits, insuring gas tight interfaces between all elements of the HYPERBOLOID construction. An exploded view is provided next.

The unique geometry, precision processing, and careful attention to quality result in a highly desirable contact design which provides:

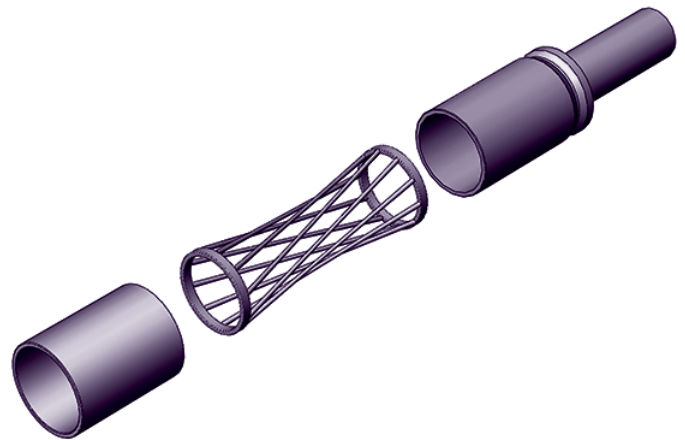

- **VLIF (Very Low Insertion Force):** Common sizes #22 and less average under one ounce per contact.
- **Extraordinary Resistance to Shock & Vibration:** Tests exceeding 300 g's without discontinuity.
- **Duty Cycle Exceeding 100,000 Mate/Demate:** The burnishing action of the wires on the pin surface is non-destructive. Unlike the "plow" and scrape action of common designs, HYPERBOLOID's gentle mating action enhances life.
- **Low, Low Contact Resistance:** The multiplicity of line contact, as opposed to point contact in other designs, provides an excellent interface exhibiting low contact resistance (often less than 1/2 of MIL spec. allowances). This characteristic also provides for a cooler running contact under load.
- **Improved Current Carrying Capacity:** The low contact resistance gives a lower °C rise from ambient under load. This feature often allows the user to operate the same size contact under higher load.
- **Highest Reliability:** In use for over 40 years under the most demanding conditions HYPERBOLOID has proven itself to be the leading design for integrity and reliability. On space platforms, ships and boats at sea, land vehicles, fighter and transport aircraft, missiles, torpedoes, medical and transplant electronics, industrial and environmental controls, rail, construction, ATE and test equipment, PGA sockets, test interface stations, and other applications, HYPERBOLOID has lived up to its promise of the highest reliability connector available.

SPECIFICATIONS

MATERIALS:

Pin Contacts:	PhBr per ASTM B139, BeCu per ASTM B196 or B197, or Cu alloy
Socket Contacts:	
Contact Wires:	BeCu per ASTM B196, or B197
Termination:	PhBr per ASTM B139 or Cu alloy
Support Elements:	Cu alloy
Hardware:	Corrosion resistant steel per ASTM A582 or Cu alloy
Insulator:	Glass filled polyester per MIL-M-24519, Type GPT-30F or ASTM D5927

FINISHES:

Pin Contacts:	Gold per MIL-DTL-45204 Type II, Class 1 (.000050), Grade C over Nickel, 0.000050 min., per SAE-AMS-QQ-N-290 over Copper flash per SAE AMS 2418
Socket Contacts:	
Contact Wires:	Gold per MIL-DTL-45204 Type II, Class 1 (.000050), Grade C over Nickel, 0.000050 min., per SAE-AMS-QQ-N-290 over Copper flash per SAE AMS 2418
Termination:	Gold per MIL-DTL-45204, Type II Class 00 (.000020), Grade C over Nickel, 0.000050 min., per SAE-AMS-QQ-N-290 over Copper per SAE AMS 2418 or solder dip over Nickel, 0.000050 min., per SAE-AMS-QQ-N-290 over Copper per SAE AMS 2418
Support Elements:	Nickel, 0.000050 min., per SAE-AMS-QQ-N-290 over Copper per SAE AMS 2418
Hardware:	Passivate per SAE-AMS2700 except Cu alloy hardware to be Nickel plate, 0.000050 min.

PERFORMANCE:

Current Rating:	See Chart - EIA-364-06 & MIL-DTL-55302 (par. 4.5.5)
Insulation Resistance:	5000 megaohms min. – EIA-364-21 & MIL-DTL-55302 (par. 4.5.8)
Contact Resistance:	See Chart EIA-364-06 & MIL-DTL-55302 (par. 4.5.5)
Test Voltage (DWV):	750 VAC RMS @ sea level - EIA-364-20 & MIL-DTL-55302 (par. 4.5.7.1) 250 VAC RMS @ 70,000 ft.
Temperature:	-65°C to +125°C (-86°F to +257°F)
Mating Force:	See Chart- MIL-DTL-55302 (par. 4.5.4)
De-mating Force:	See Chart- MIL-DTL-55302 (par. 4.5.4)
Contact Life:	See Chart - MIL-DTL-55302 (par. 4.5.9)
Solderability:	(Where Applicable) IPC/EIA J-STD-002, Category 3

DIMENSIONS:

Catalog product dimensions are nominal.
All dimensions listed are in inches [millimeters] unless otherwise stated
For linear and positional tolerances, contact factory.

All information contained herein is believed to be reliable as of the date of publication, but is subject to change without notice. Current product drawings and specifications are available upon request from IEH.

IEH warrants its products to be free of defects affecting normal use. If any shipment is found to be defective we will accept return for repair or replacement at our option within one year of shipment. IEH is not responsible for incidental or consequential damages arising out of the use of our products.

CONTACT SPECIFICATIONS

CONTACT SIZES		CURRENT RATING	CONTACT RESISTANCE	RETENTION FORCE (MIN.)	LIFE CYCLES
SIZE	INCH [mm]	AMPS	MILLIOHMS	OUNCES	
#28	0.016 [0.41]	3.5	<8	0.3	>100,000
#24	0.024 [0.61]	6.5	<5	0.3	
#22	0.030 [0.76]	8	<5	0.5	
#20	0.040 [1.02]	13	<2.5	0.5	
#16	0.062 [1.57]	15.5	<2.5	0.5	
#14	0.078 [1.98]	18.5	<1.5	1.2	
#12	0.093 [2.36]	27	<1	2.5	
#8	0.142 [3.61]	40	<0.5	6.0	
N/A	0.169 [4.29]	100	<0.4	10.0	

NOTES:

1. Ampacity ratings shown should be derated based on application and are guidelines; tested at 30°C rise. For stand-alone, full service ratings, supported by test data, please refer to IEH's Contacts Catalog, or contact the factory
2. Hyperboloid interconnects are unequaled for service under severe shock and vibration. They exhibit no intermittence through test levels exceeding 300 G's.

All information contained herein is believed to be reliable as of the date of publication, but is subject to change without notice. Current product drawings and specifications are available upon request from IEH.

IEH warrants its products to be free of defects affecting normal use. If any shipment is found to be defective we will accept return for repair or replacement at our option within one year of shipment. IEH is not responsible for incidental or consequential damages arising out of the use of our products.

ORDERING CHART

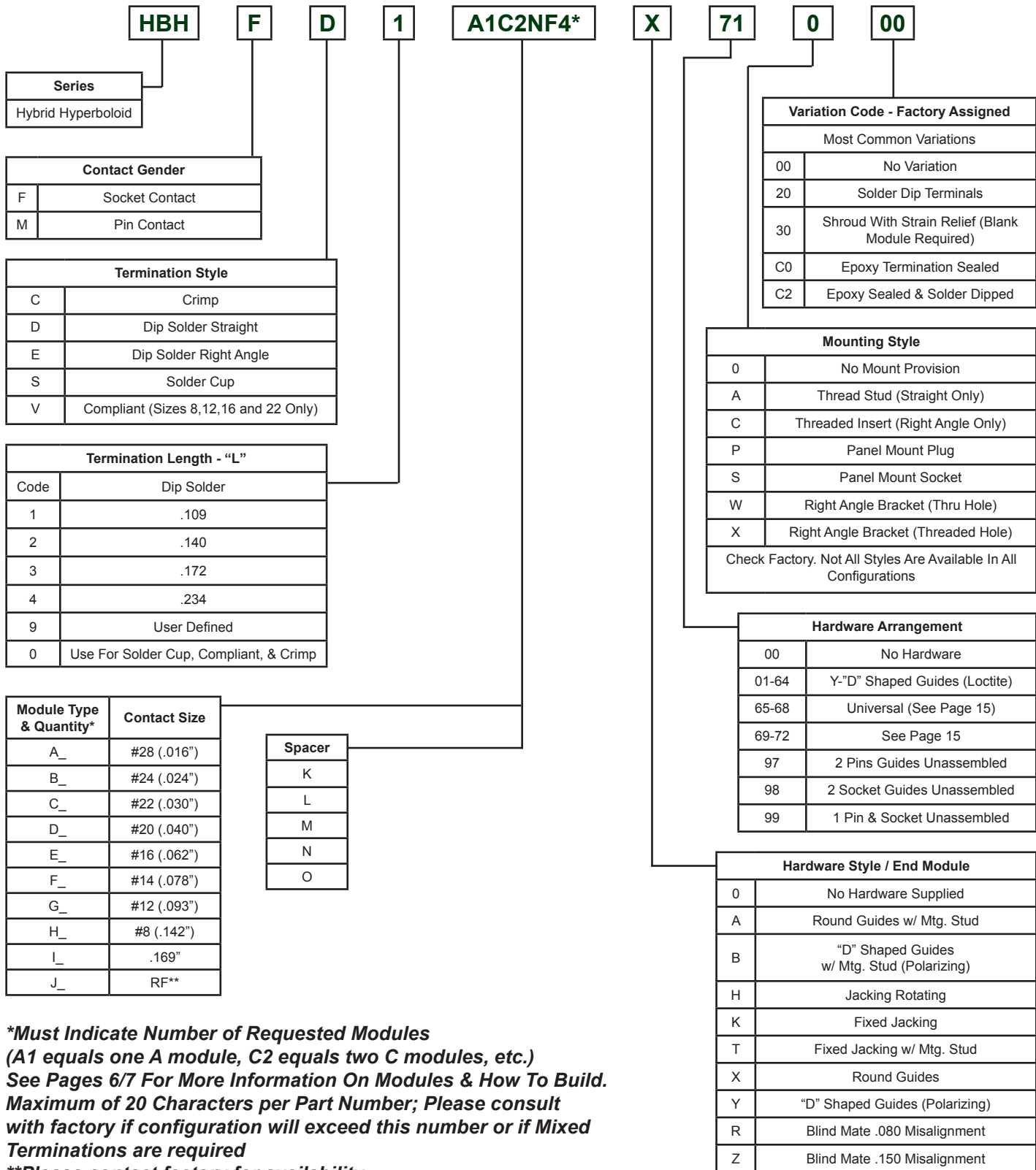

***Must Indicate Number of Requested Modules (A1 equals one A module, C2 equals two C modules, etc.)
 See Pages 6/7 For More Information On Modules & How To Build.
 Maximum of 20 Characters per Part Number; Please consult with factory if configuration will exceed this number or if Mixed Terminations are required
 Please contact factory for availability

MODULE CHART

(Socket Modules Shown, As Viewed From Termination Face)

A
#28 (.016") 5 Contacts
Module Width: .141"(3.6mm)

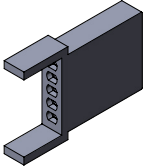

B
#24 (.024") 4 Contacts
Module Width: .141"(3.6mm)

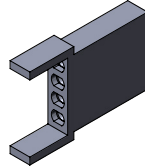

C
#22 (.030") 4 Contacts
Module Width: .185"(4.7mm)

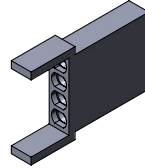

D
#20 (.040") 3 Contacts
Module Width: .185"(4.7mm)

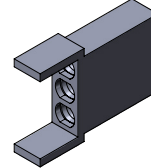

E
#16 (.062") 2 Contacts
Module Width: .215"(5.5mm)

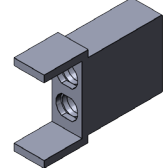

F
#14 (.078") 2 Contacts
Module Width: .250"(6.4mm)

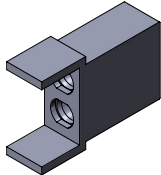

G
#12 (.093") 2 Contacts
Module Width: .275"(7.0mm)

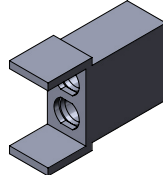

H
#8 (.142")
Module Width: .575"(14.6mm)

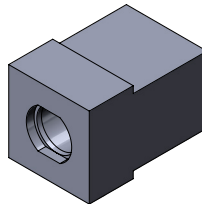

I
.169"
Module Width: .575"(14.6mm)

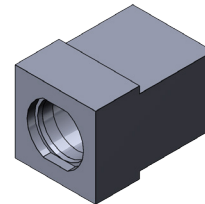

J
RF
Module Width: .575"(14.6mm)

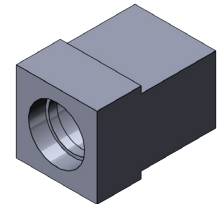

Module	Contact Size/ Module Type	#Of Contact Positions Per Module	1 X Module Width
A	#28 (.016")	5	.141"(3.6mm)
B	#24 (.024")	4	.141"(3.6mm)
C	#22 (.030")	4	.185"(4.7mm)
D	#20 (.040")	3	.185"(4.7mm)
E	#16 (.062")	2	.215"(5.5mm)
F	#14 (.078")	2	.250"(6.4mm)
G	#12 (.093")	2	.275"(7.0mm)
H	#8 (.142")	1	.575"(14.6mm)
I	.169"	1	.575"(14.6mm)
J	RF	1	.575"(14.6mm)
K	Spacer Blank	N/A	.062"(1.6mm)
L	Spacer Blank	N/A	.078"(2.0mm)
M	Spacer Blank	N/A	.136"(3.5mm)
N	Spacer Blank	N/A	.192"(4.9mm)
O	Spacer Blank	N/A	.220"(5.6mm)

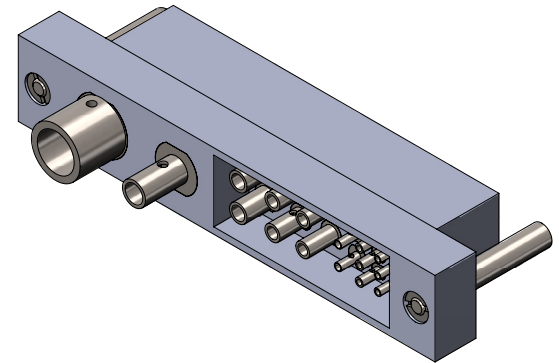

As Viewed From Termination Face

Construction Note: Modules are used for ordering purposes only. All connectors are one piece.

HOW TO ORDER / BUILD

MODULE CONFIGURATION LEFT TO RIGHT AS LOOKING AT THE MATING FACE OF THE CONNECTOR

EXAMPLE:

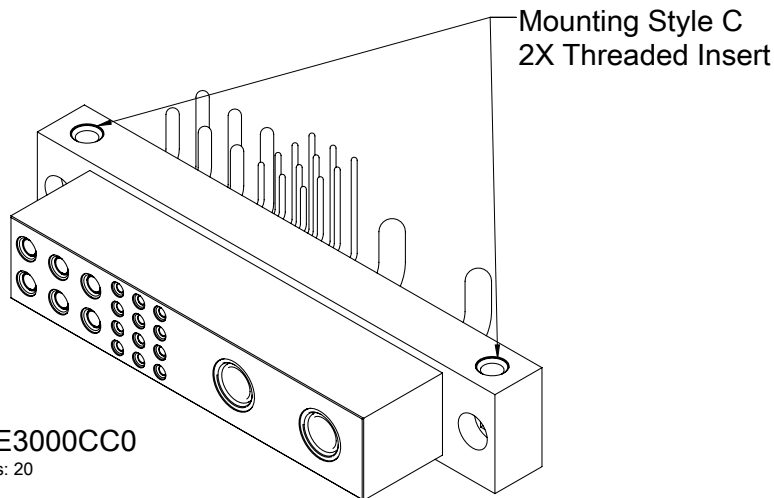
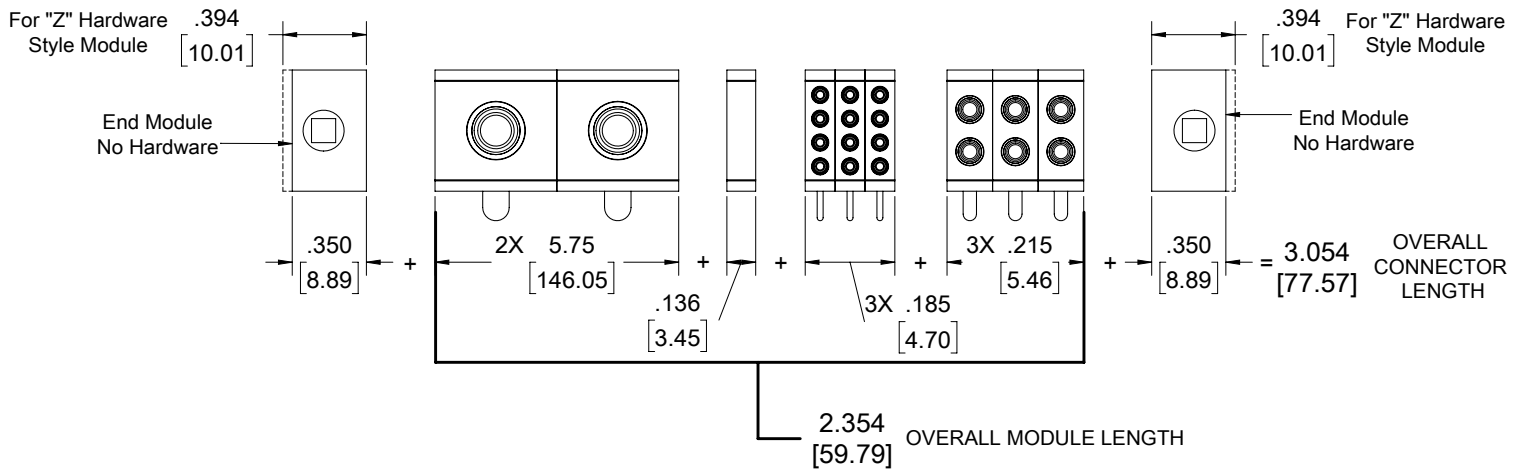

HBHFE2H2NC3E3000CC0
Max Characters: 20

Refer To Module Pages For More Dimensions

Connector Maximum Overall Width= 3.968" (100.8mm)

Connector Minimum Overall Width= 0.528" (13.4mm)

Please note contact location 1 appears on upper right contact Module -- as shown

INSULATOR, RECEPTACLE

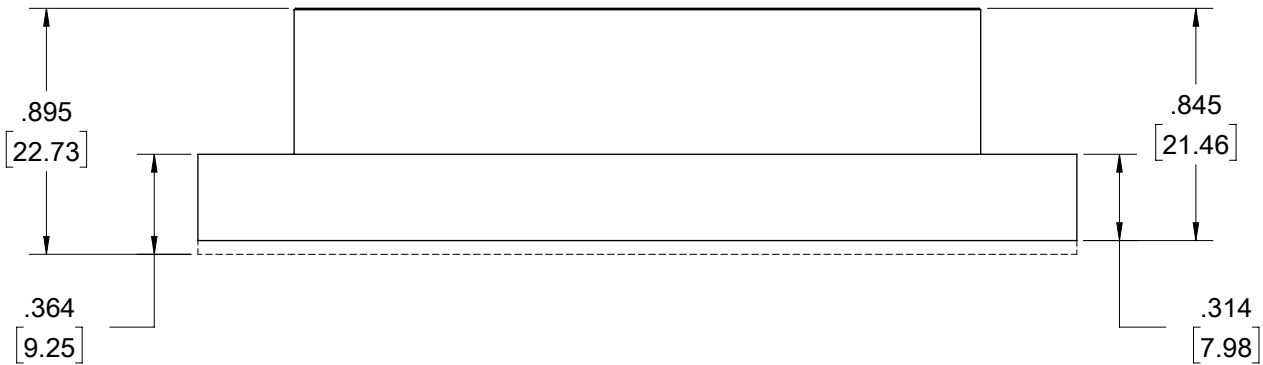
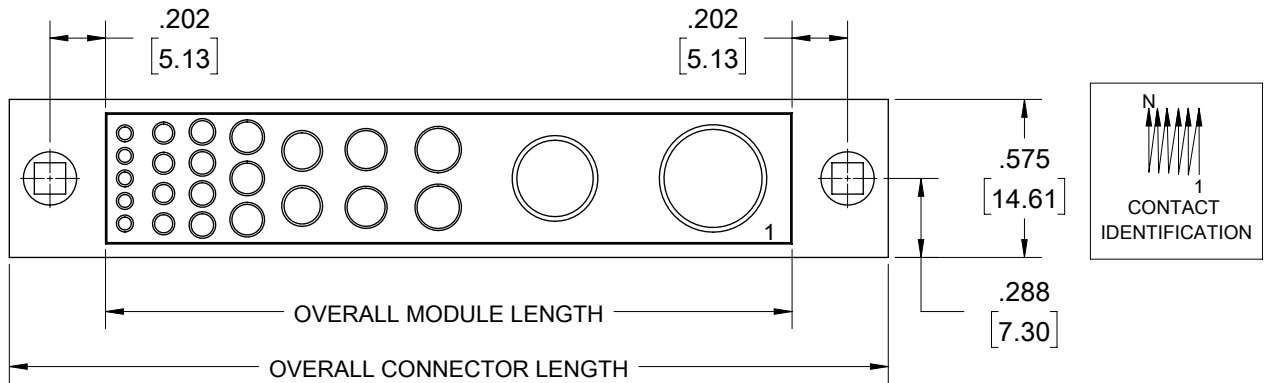

Connector dimensions with straight solder dip terminations only

Connector dimensions with all other termination styles

Mated Height of Connectors: 1.340 [34.04]

Please note contact location 1 appears on lower right contact Module -- as shown

INSULATOR, PLUG

Connector dimensions
with straight solder dip
terminations only

Connector dimensions
with all other
termination styles

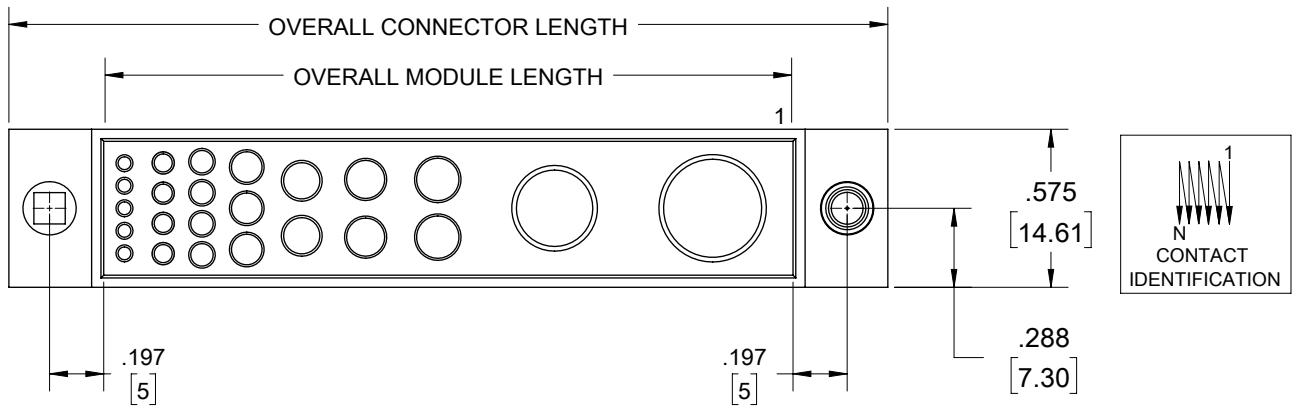
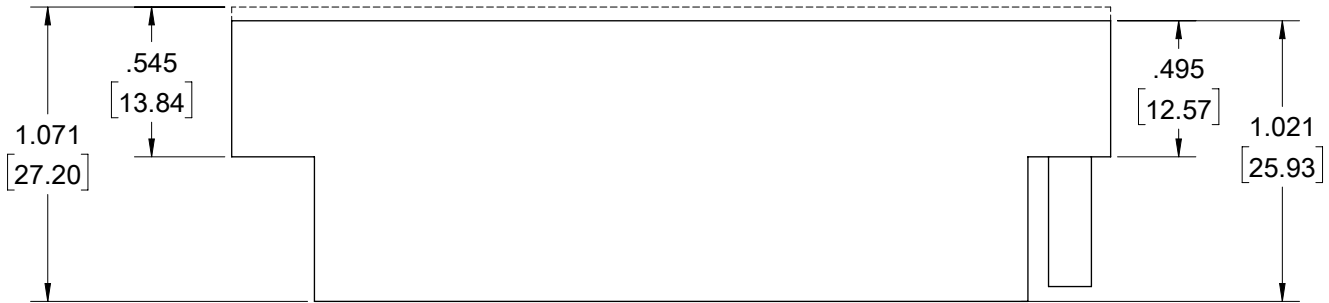

Mated Height of Connectors: 1.340 [34.04]

Please note contact location 1 appears on upper right contact Module -- as shown

MODULES, SIGNAL CONTACTS

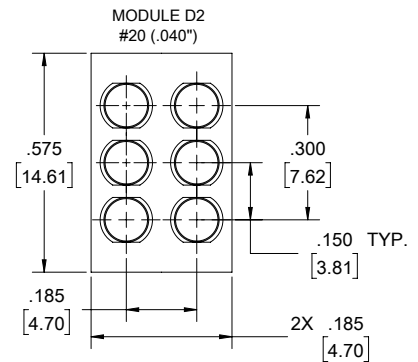
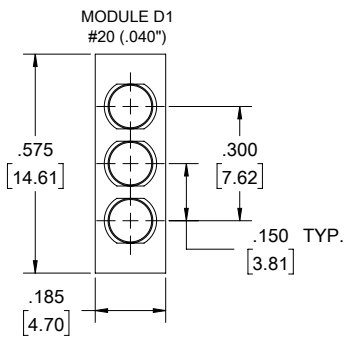
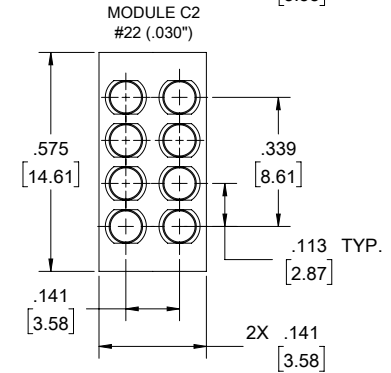
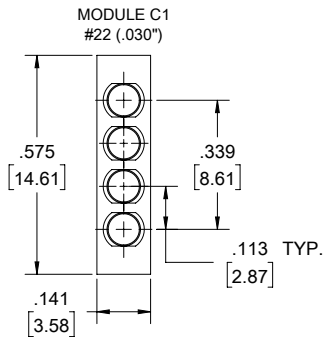
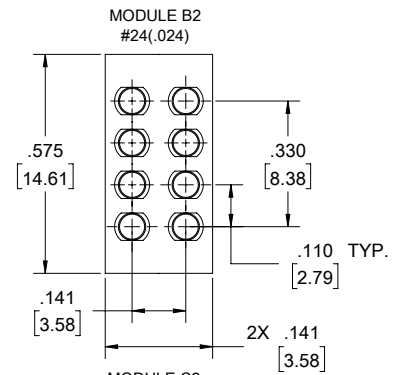
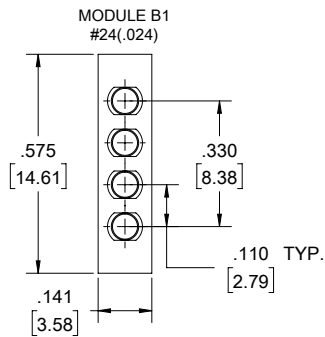
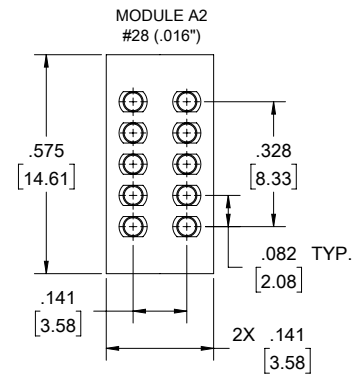
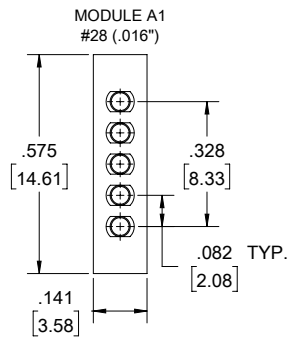

*Part configuration is not limited to the amount of modules shown.
Illustration used to convey single and multiple module dimensions*

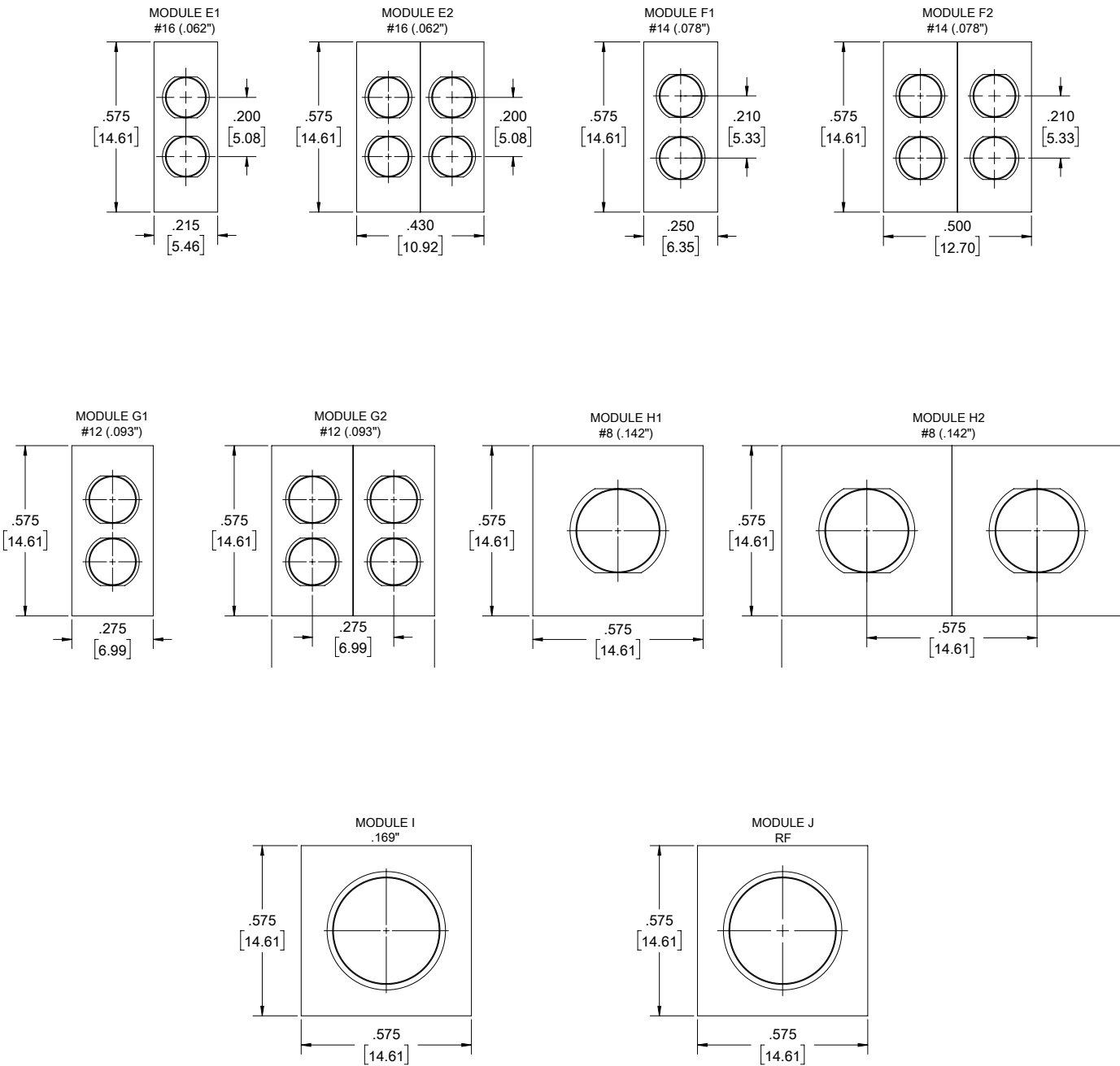
MODULES, POWER CONTACTS, RF, OPTICAL

Part configuration is not limited to the amount of modules shown.
Illustration used to convey single and multiple module dimensions

MODULES, SPACERS

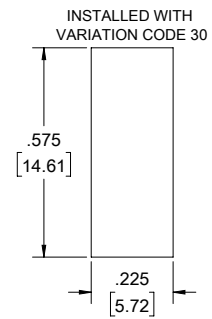
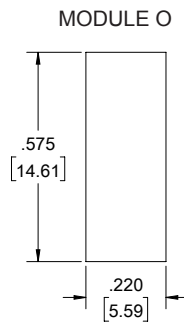
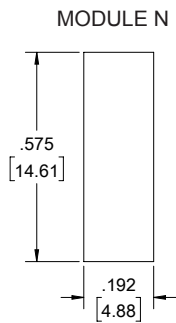
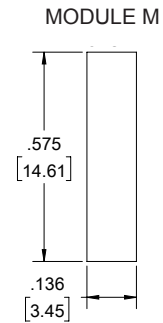
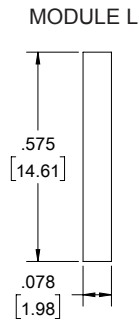
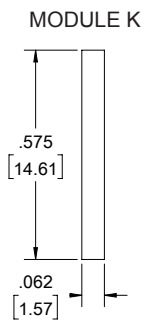

HARDWARE STYLE / END MODULE RECEPTACLE

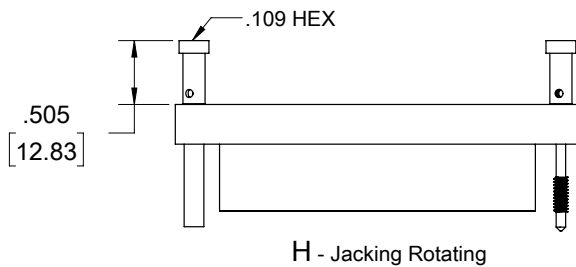
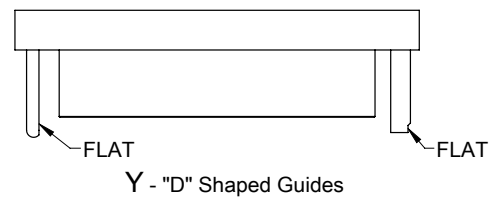
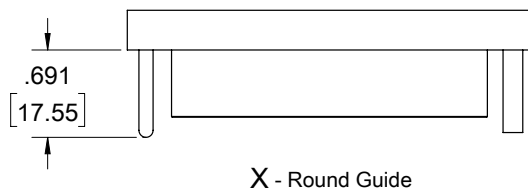
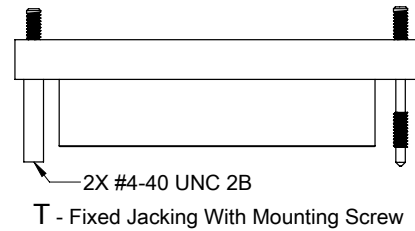
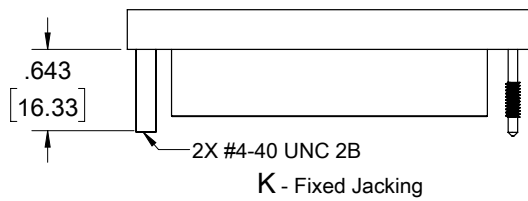
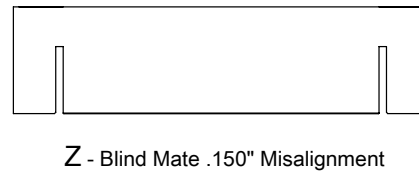
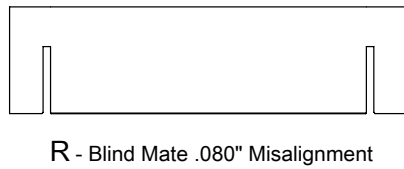
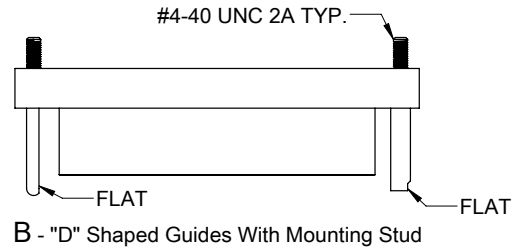
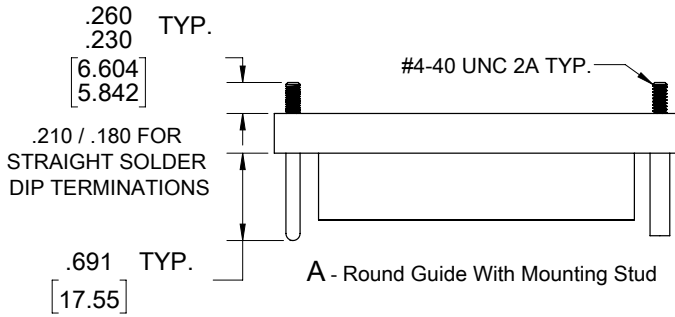

		HARDWARE COMPATIBILITY								
		PLUG								
		A	B	H	K	R	T	X	Y	Z
		RECEPTACLE	A	•						
B			•							•
H					•		•			
K				•						
R						•				
T				•						
X	•								•	
Y			•							•
Z										

HARDWARE STYLE / END MODULE PLUG

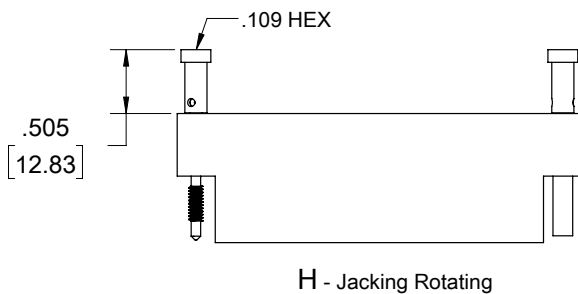
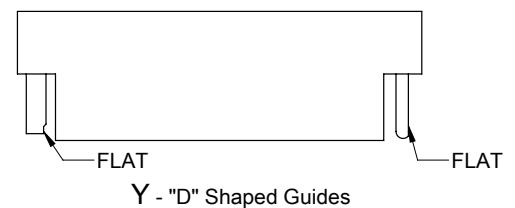
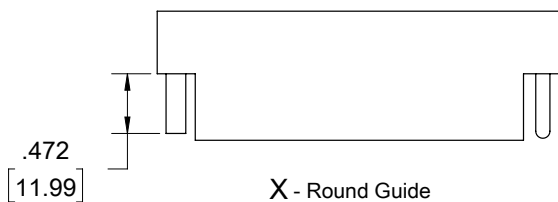
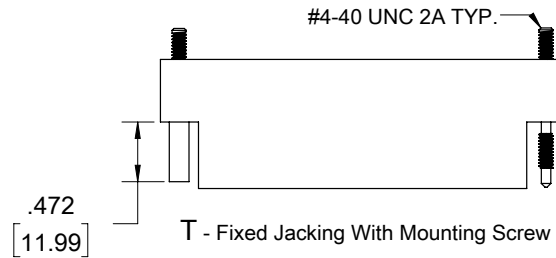
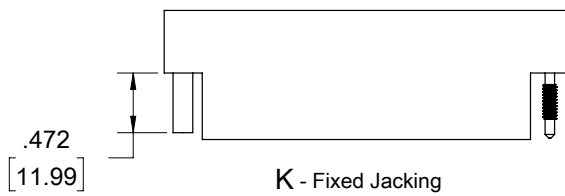
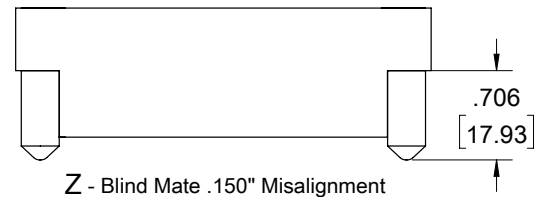
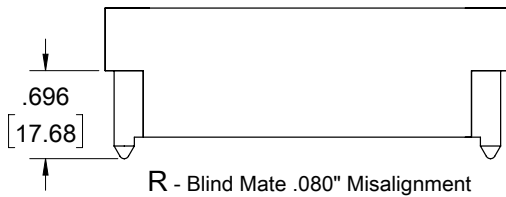
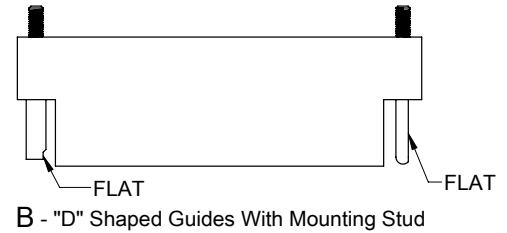
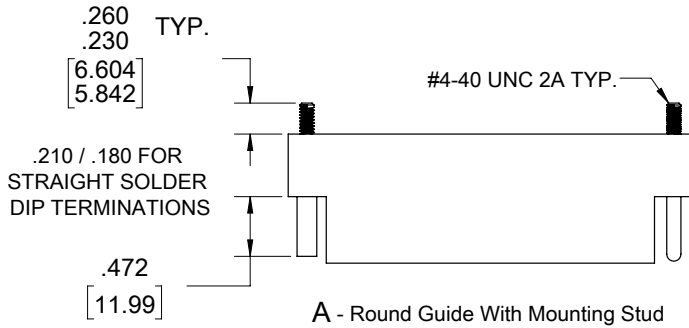

		HARDWARE COMPATIBILITY									
		PLUG									
RECEPTACLE		A	B	H	K	R	T	X	Y	Z	
	A	•							•		
	B		•							•	
	H				•		•				
	K				•						
	R					•					
	T				•						
	X	•							•		
	Y		•							•	
	Z										•

HARDWARE ARRANGEMENT POLARIZATION CHART

AS VIEWED FROM THE MATING FACE

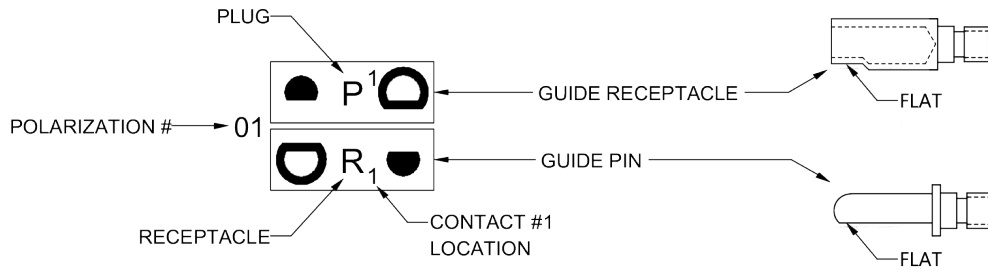

01 - 64 USE FOR HARDWARE STYLE 'Y' AND 'B'

01	09	17	25	33	41	49	57
02	10	18	26	34	42	50	58
03	11	19	27	35	43	51	59
04	12	20	28	36	44	52	60
05	13	21	29	37	45	53	61
06	14	22	30	38	46	54	62
07	15	23	31	39	47	55	63
08	16	24	32	40	48	56	64

UNIVERSAL TEST

USE FOR OPTION: A,H,K,X,T

65	66	67	68	69	70	71	72
----	----	----	----	----	----	----	----

MOUNTING STYLES

RECEPTACLE

PLUG

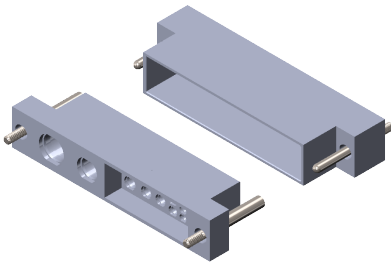

.195 FOR STRAIGHT SOLDER DIP TERMINATIONS [6.22] .245 TYP.

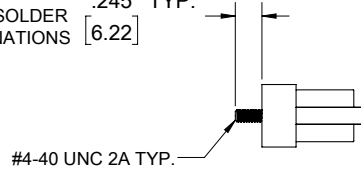

#4-40 UNC 2A TYP.

A
THREADED STUD
COMPATIBLE W/ HARDWARE 0, A, B, T

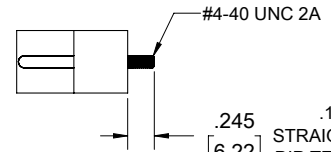

#4-40 UNC 2A

.195 FOR STRAIGHT SOLDER DIP TERMINATIONS [6.22] .245

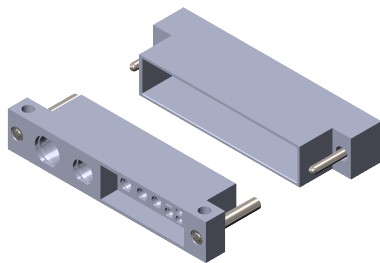

.157 [3.99]

#2-56 UNC 2A TYP THREADED INSERT

C
THREADED INSERT
COMPATIBLE W/ HARDWARE 0, A, B, H, K, T, X, Y

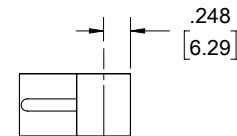

.248 [6.29]

#2-56 UNC 2A TYP THREADED INSERT

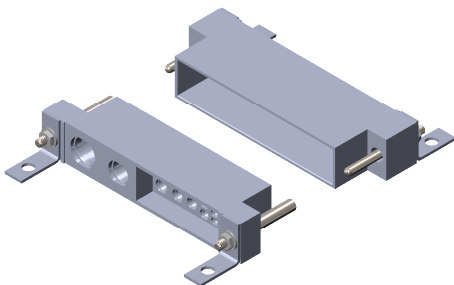

.640 [16.26] .390 [9.91]

W - THRU HOLE X - #2-56 UNC 2A

W & X
RIGHT ANGLE BRACKET
COMPATIBLE W/ HARDWARE STYLE 0, A, B, H, K, T

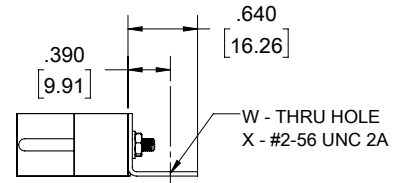

.640 [16.26]

.390 [9.91]

W - THRU HOLE X - #2-56 UNC 2A

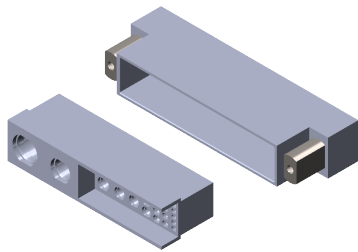
MOUNTING STYLES

P
 PLUG, PANEL MOUNT, FLUSH
 COMPATIBLE W/ HARDWARE 0

RECEPTACLE

N/A

PLUG

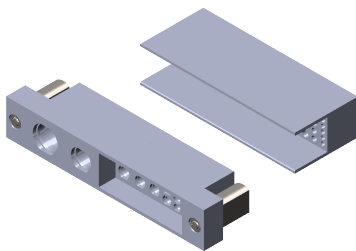
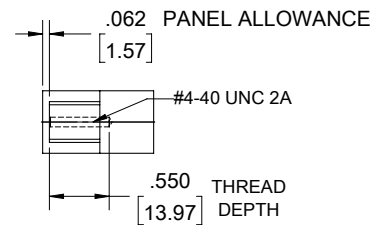

S
 SOCKET, PANEL MOUNT, FLUSH
 COMPATIBLE W/ HARDWARE 0

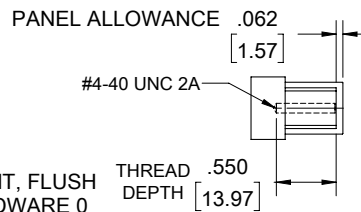

N/A

TERMINATION STYLE RECEPTACLE

SOLDER CUP

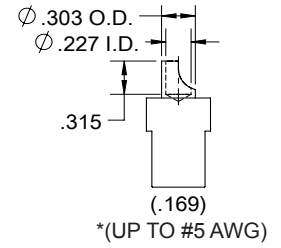
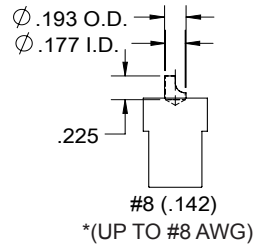
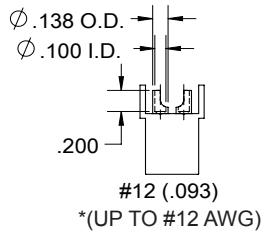
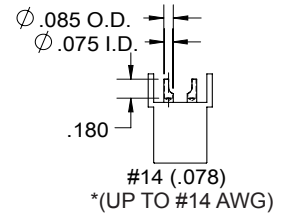
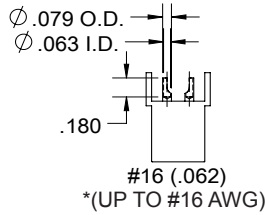
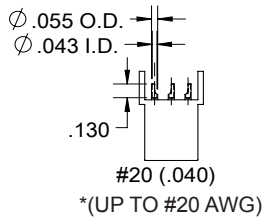
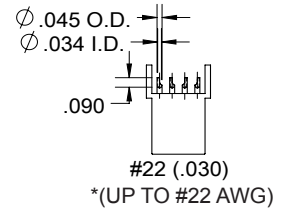
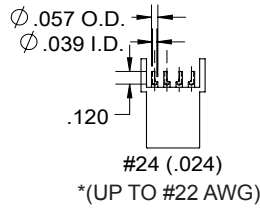
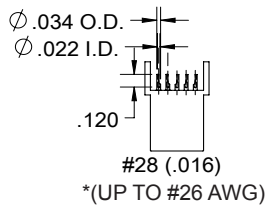

CRIMP

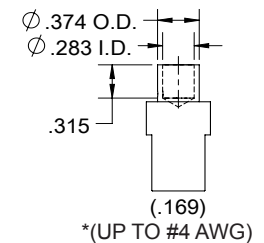
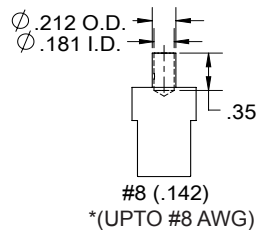
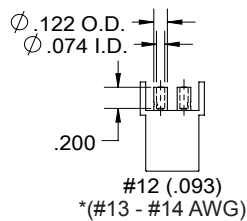
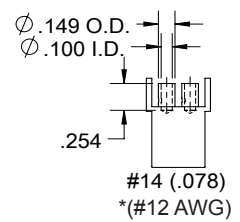
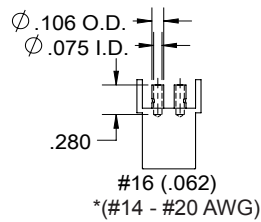
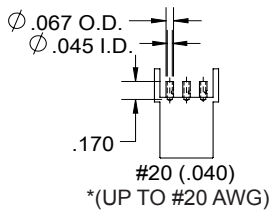
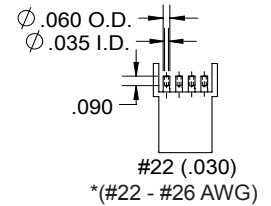
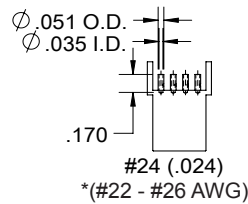
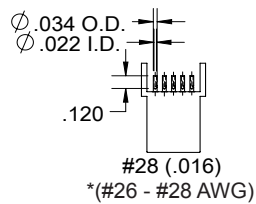

* ACCEPTABLE WIRE SIZES FOR TERMINATIONS

TERMINATION STYLE RECEPTACLE

SOLDER DIP

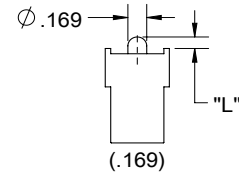
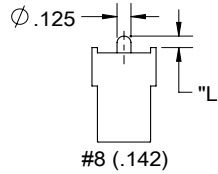
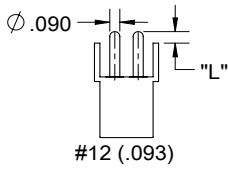
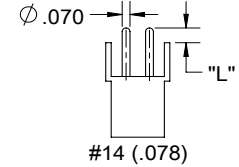
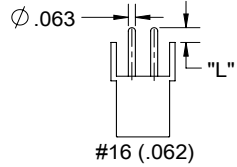
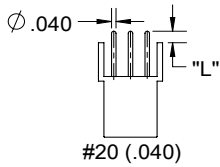
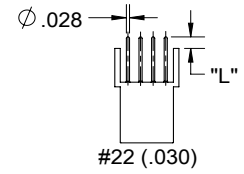
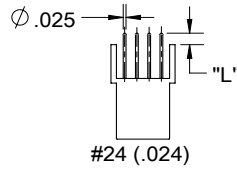
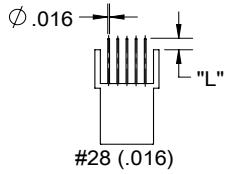

SOLDER DIP RIGHT ANGLE

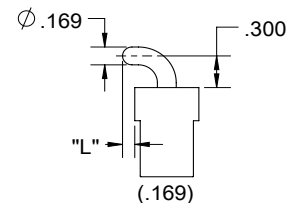
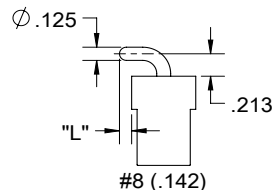
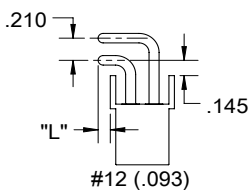
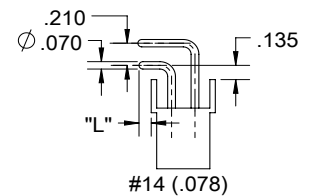
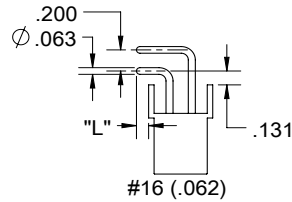
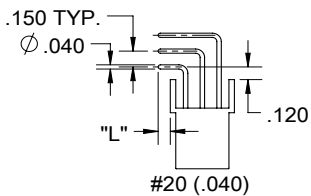
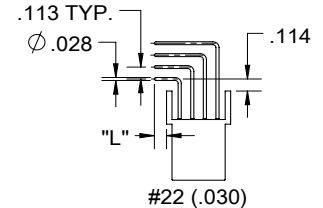
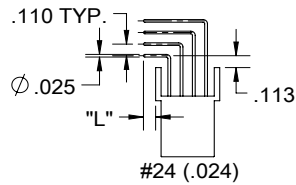
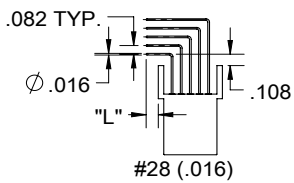

PCB Recommended dimensions and tolerances, positional tol. .004", PTH .006"-.015" larger than the pin diameter; PTH diameter tol. +/- .003"

TERMINATION STYLE RECEPTACLE

COMPLIANT

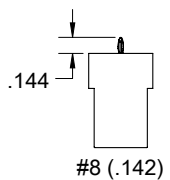
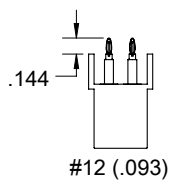
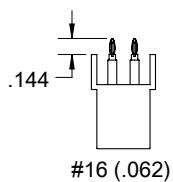
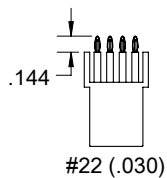

PCB Recommended dimensions and tolerances:

Positional tolerance .004"

PTH diameter .040"

PTH diameter tolerance +/- .002"

Minimum PCB thickness .062"

TERMINATION STYLE PLUG SOLDER CUP

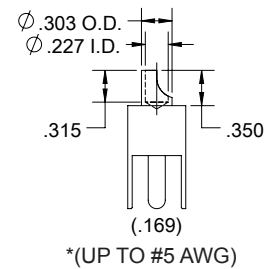
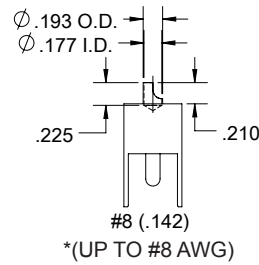
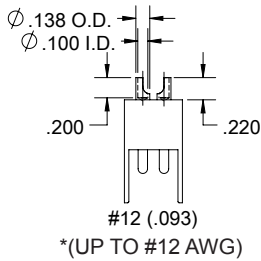
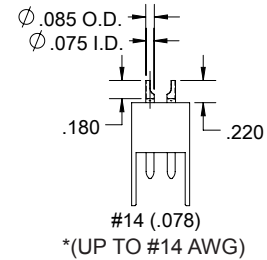
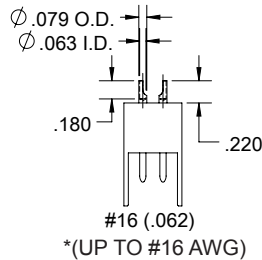
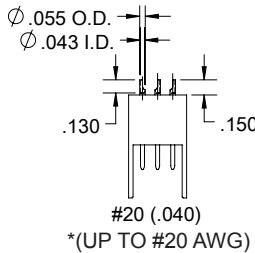
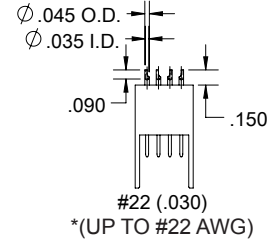
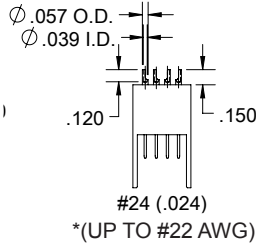
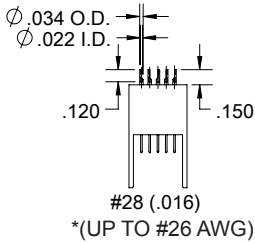

CRIMP

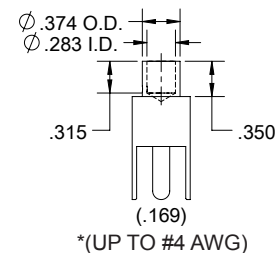
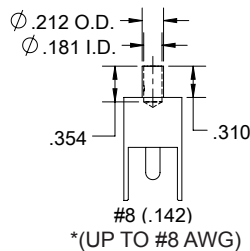
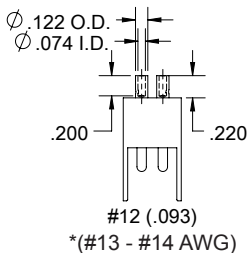
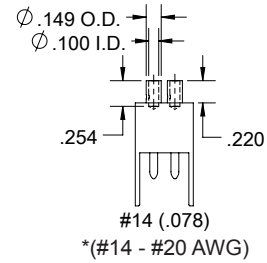
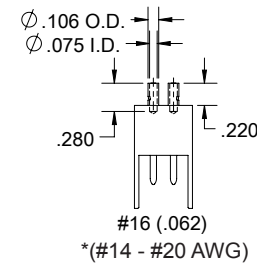
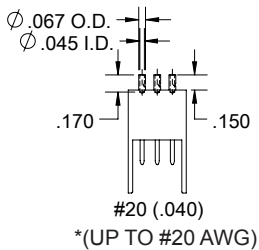
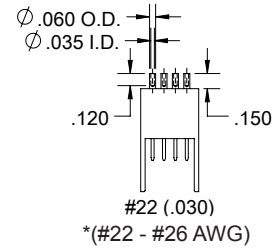
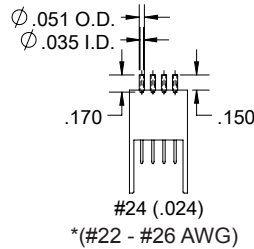
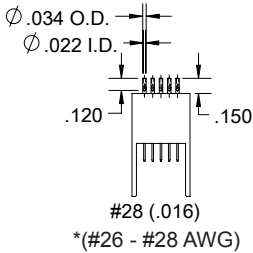

* ACCEPTABLE WIRE SIZES FOR TERMINATIONS

TERMINATION STYLE PLUG SOLDER DIP

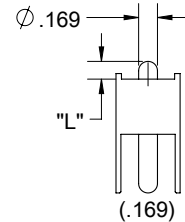
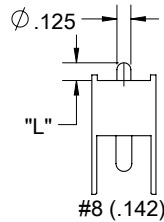
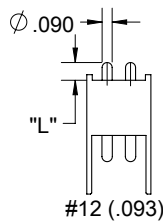
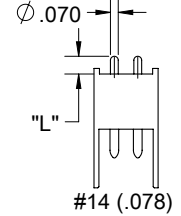
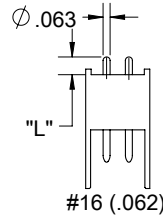
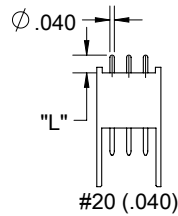
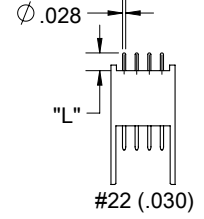
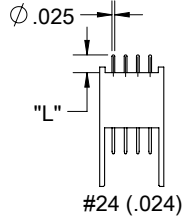
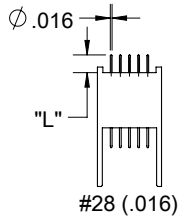

SOLDER DIP RIGHT ANGLE

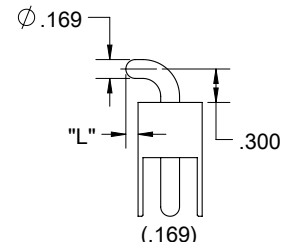
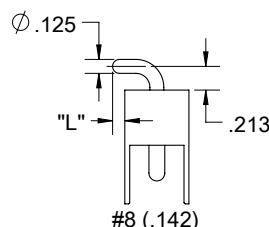
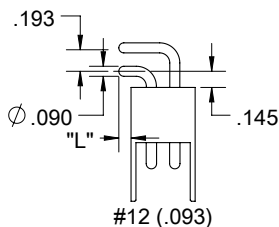
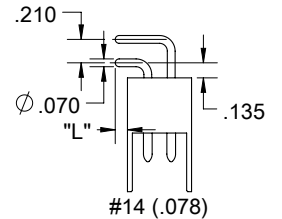
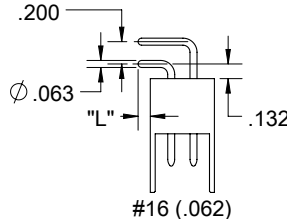
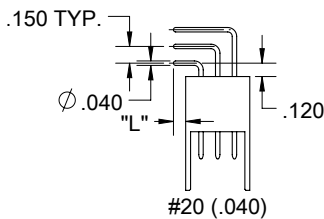
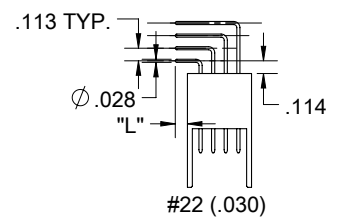
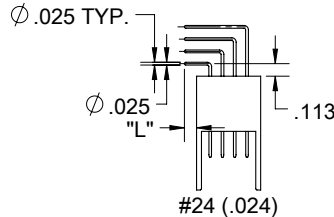
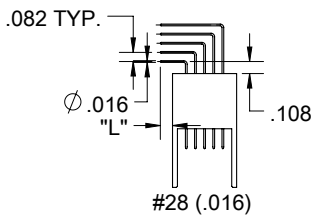

PCB Recommended dimensions and tolerances, positional tol. .004", PTH .006"-.015" larger than the pin diameter; PTH diameter tol. +/- .003"

TERMINATION STYLE PLUG

COMPLIANT

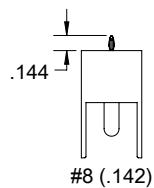
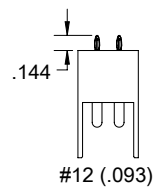
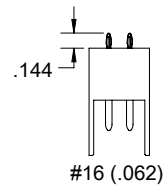
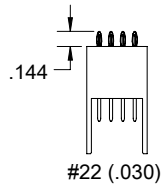

PCB Recommended dimensions and tolerances:

Positional tolerance .004"

PTH diameter .040"

PTH diameter tolerance +/- .002"

Minimum PCB thickness .062"

CONNECTOR WITH SHROUD

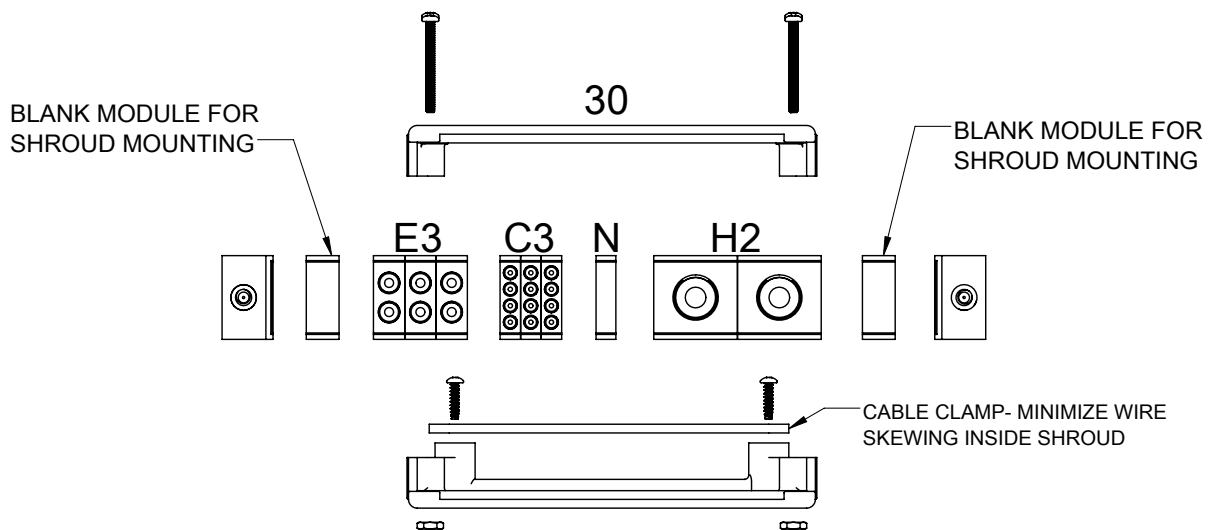
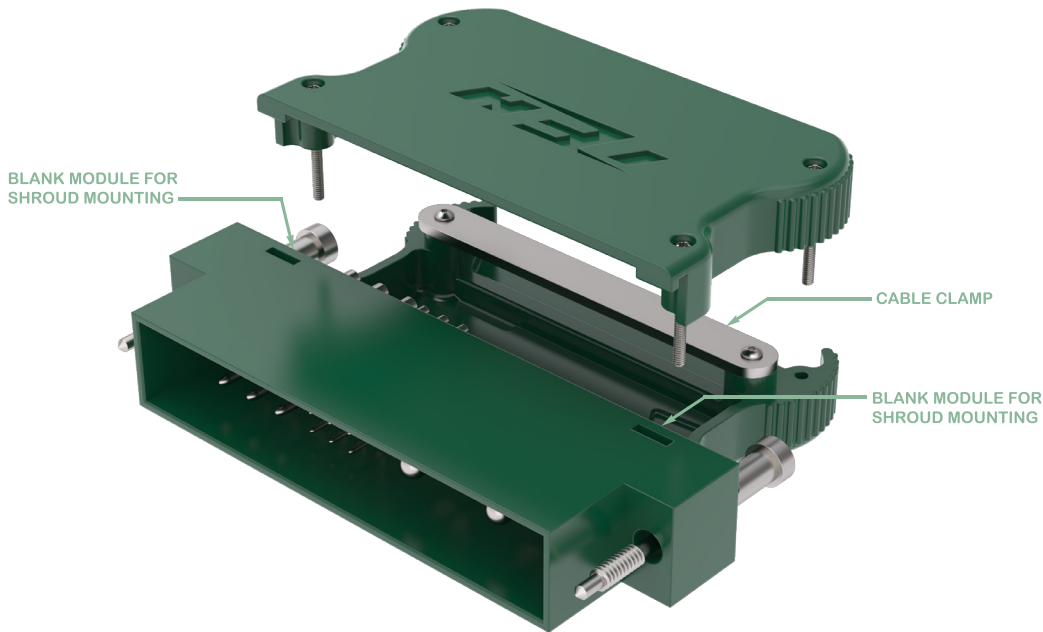

HBHMS0E3C3NH2H71030

SHROUD WITH STRAIN RELIEF AND BLANK MODULE FOR MOUNTING

IEH Quality Statement

Listening to our customers and meeting their needs while
continuously improving our processes and services



IEH CORPORATION

140 58TH STREET, 8E, BROOKLYN, NY 11220

PHONE (718) 492-4448 • FAX (718) 492-9898

www.iehcorp.com • ieh@iehcorp.com