

AS39029 QPL and Glenair Commercial
**High-Performance
Connector Contacts**

United States ■ United Kingdom ■ Germany ■ France ■ Nordic ■ Italy ■ Spain ■ Japan

First Edition • January 2011

Aircraft On Ground? Need Contacts Now? AS39029 In Stock (Specials Too!)



1211 Air Way

Glendale, California 91201-2497

Telephone: 818-247-6000 · Facsimile: 818-500-9912 · E-mail: sales@glenair.com

United States · United Kingdom · Germany · Nordic · France · Italy · Spain · Japan

www.glenair.com

Intro

Introduction

Complete Overview of Qualified and Commercial Contacts

Intro

A

AS39029 Crimp Contacts

*M39029 Contact Selection Guide
Electrical Pin and Socket Crimp Contacts*



A

B

High Performance Shielded Contacts

*Shielded Contact Cross Reference
Coaxial
Twinax
Quadrax
Other Shielded Contacts*



B

C

Fiber Optic Termini

*MIL-PRF-29504 for D38999
MIL-PRF-28876
Series 80 Mighty Mouse
Special Size #16 COTS Front Release
ARINC Type
Glenair High Density (GHD)
GFOCA
Next Generation NGCON*



C

D

Special Purpose Contacts

*Series 80 Mighty Mouse #23 Contacts
High Power Contacts
Sealing Plugs
Pneumatic Contacts
Thermocouple Contacts
PC Tail Contacts*

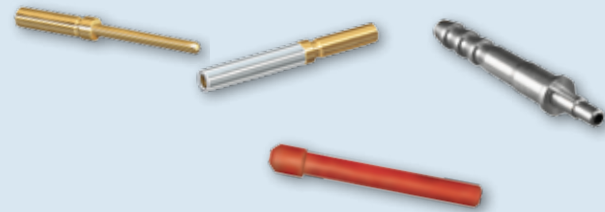

D

E

Tools and Accessories

*Insertion and Extraction Tools
Crimp Tools*



E

Index

Index

Part Number Index

Index



Glenair brings a new perspective to the supply of high-performance Mil-Spec and commercial contacts: High Availability! Whether you need a standard duty socket for a MIL-DTL-28840 connector or an extended duty pin for MIL-DTL-38999 Series III, we have you covered with products that are always in stock—with no dollar or quantity minimums. In addition to the broadest selection and availability, Glenair also delivers outstanding interconnection compatibility. Glenair QPL SAE-AS39029 as well as our proprietary contact series are guaranteed to mate properly and perform at the upper limits of application requirements.

About SAE AS39029 Crimp Contacts

In a marketplace saturated with specialty interconnection media, the SAE-AS39029 crimp contact is still the “bread and butter” of the circular connector world. Serving platforms like the D38999, M28840 and countless others, AS39029 crimp contacts continue to offer reliable power and signal transmission in ruggedized applications. A myriad of sizes, termination options and materials mean that end users don’t have to compromise performance or reliability.

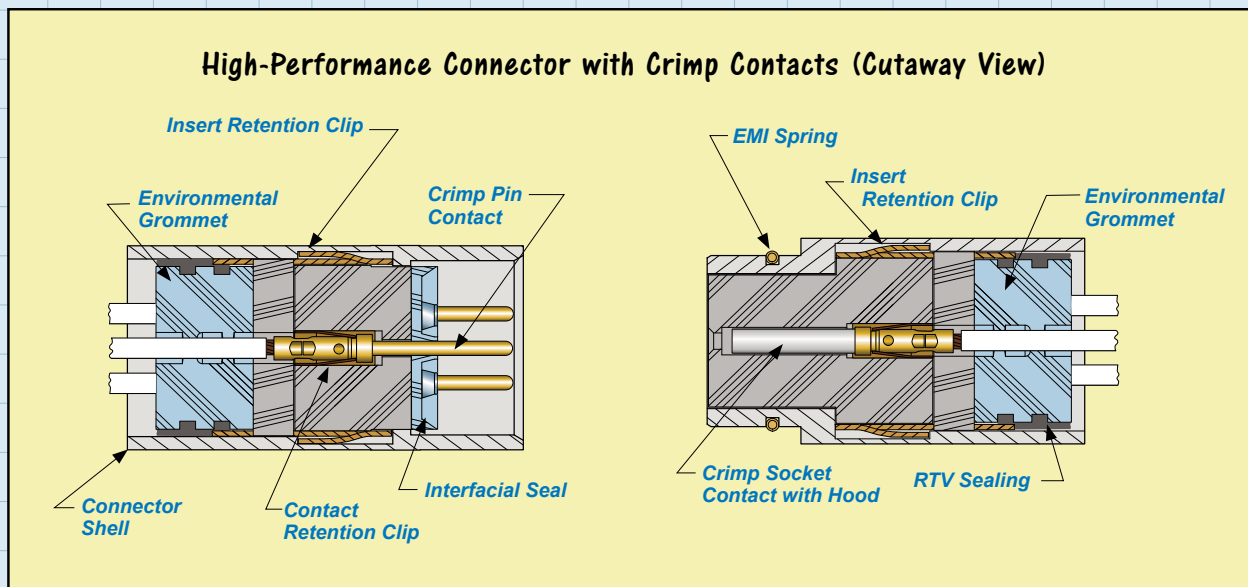

Crimping results in a gas tight connection between the wire and its terminal. Although there are certainly alternatives to crimping, such as ultrasonic welding, resistance welding, insulation displacement technologies and so on, no other available technology delivers the short cycle times, flexibility and low overall cost of crimping—making it the termination technology of choice for most high-performance connector systems.

Crimp connectors are most commonly used to terminate stranded wire. Crimp-on terminals are attached by inserting the stripped end of the wire into the barrel end of the terminal, which is then mechanically deformed (crimped). Special crimp tools are a must, and are supplied with appropriate accessory attachments to ensure reliable terminations for every wire and contact combination. Military Specification MIL-DTL-22520 provides the aerospace/defense industry with a common set of rugged, reliable hand crimp tools. This specification controls the voltage drop and tensile strength of crimp terminations. Daniels Manufacturing Corporation is the leading manufacturer of these tools.

The AS39029 product series supplied by Glenair includes all the most popular standard and extended duty pin and socket contacts for use in high-performance circular and rectangular multi-pin connectors. We are also well positioned to supply special-purpose contacts to meet unique application requirements.

Introduction to Crimp Contacts High Performance Shielded



About High Performance Shielded Contacts

Glenair shielded contacts are fabricated from the best available materials and manufacturing processes. Conductive elements are gold-plated copper alloy. Dielectrics are high-performance fluorocarbon. When applicable, contacts are approved to SAE AS39029.

Shielded Coaxial Contacts

Shielded coaxial contacts have a special role in the interconnect system and are designed for use in a wide range military and aerospace connectors that service analog radio frequency or microwave applications. Most Glenair cylindrical connectors, including MIL-DTL-38999, can accommodate shielded coaxial contacts. Rectangular connector packages, such as our high-performance HiPer-D are also ideally suited for shielded high frequency contacts. Glenair coaxial contacts are specified according to size, cable choice and impedance. The contacts are easily incorporated into standard 8, 12 and 16 size contact cavities, enabling users to interchange high-frequency contacts into connector insert arrangements originally designed for power or signal contacts. Special 50 Ohm matched impedance contacts are also available. Various grades of coaxial cables can be supplied directly by Glenair, or other commercial suppliers.

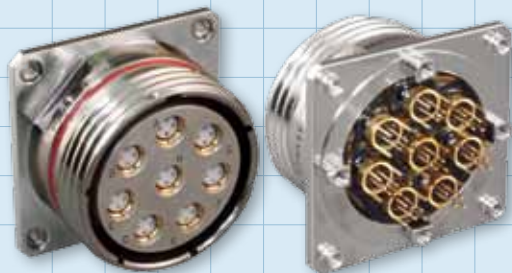
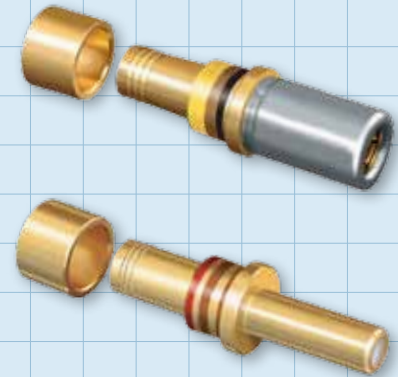

Quadrax

A Quadrax contact is really a “connector within a connector.” These unique high-speed contacts house four discrete size 24 pin or socket contacts within each keyed size 8 crimp body. Two sets of twisted pair wires terminate to the size 24 contacts, while the overall shield is grounded via the outer size 8 shell—affording 360° shielding. These high speed contacts have outstanding EMI compatibility for high data transfer digital applications where little or no power is needed. Standard crimping tools can be used to terminate all components, making shop or field assembly fast and simple.

Shielded Concentric Twinax

These contacts are designed for high-speed twisted pair applications that count on reliable shielding and contact durability. The concentric twinax cartridge is designed for easy crimp termination of twisted pair cable and shielding, and are designed specifically for use in MIL-DTL-38999 connectors. Unlike standard twinax designs, Glenair concentric twinax contacts deliver outstanding shield integrity from the conductor through the connector and do not require contact polarization within the insert. Glenair size #8 concentric twinax contacts feature a hooded socket and hardened plating for outstanding durability. Pin contacts are chamfered for easy and reliable mating. Termination is supported with easy to follow crimp instructions. Assembly tooling is available for these and all Glenair contacts.



Introduction to Crimp Contacts Fiber Optic Termini

About Fiber Optic Contacts

Today, the use of fiber optic systems to carry digitized video, voice and data is universal. High-performance fiber optic interconnect technologies, combined with satellite and other broadcast media, enable high-speed specialized applications in avionics, robotics, weapon systems, sensors, space and other high performance environments. Highly engineered fiber optic contacts, or termini, are the key to delivering low data loss and reliable, repeatable performance in fiber optic connection systems.

Fiber Optic Interconnect Termini

Fiber optic connectors are designed to be connected and disconnected many times without affecting the optical performance of the fiber circuit. Connectors can be thought of as transition devices which make it possible to divide fiber optic networks into interconnected subsystems and to facilitate the attachment of individual branches of the system to a transmitter, receiver or another fiber. The MIL-DTL-38999 connector is currently the most commonly specified multi-pin cylindrical interconnect in both fiber and copper conductor aerospace applications. When used to connect multiple strands of fiber simultaneously, the D38999 connector functions as a container or shell for the precision termini which perform the actual marriage of the fiber strands.

Over the past two decades there have been dramatic tolerance improvements in terminus design to ensure precise, repeatable, axial and angular alignment between pin and socket termini within the connector shell. Ferrule design, critical to the performance of the termini, has traditionally relied on a machined stainless steel ferrule incorporating a precision micro-drilled hole.

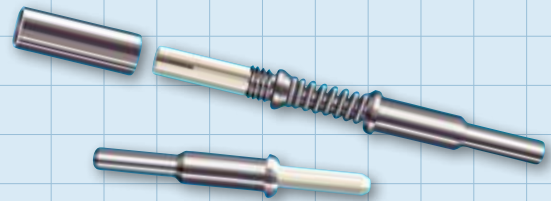

Glenair's fiber optic termini for D38999 Series III connectors are qualified to MIL-PRF-29504/4 and /5 requirements. Unique precision ceramic ferrules, with concentricity and diametric tolerances controlled within a micron (.00004 of an inch), meet the needs of high bandwidth and low allowable insertion loss applications. Glenair's ferrules are approximately 10 times more accurate than alternative designs, and have reduced insertion loss values from 1.5dB to less than .5dB. These products are ideally suited for aerospace applications.

Glenair has also manufactured and qualified fiber optic interconnection systems for other branches of the military, including those used in mission-critical ground, sea and space applications. Contact termini for these fiber optic systems incorporate many of the latest technologies, including integrated retention clips, IPC polish keying, environmental sealing and more. Our single and multichannel fiber optic termini utilize the latest materials technology and are designed for use with Glenair's family of fiber optic connectors as well as third party products. From MIL-DTL-38999 to MIL-DTL-28876, Glenair has a fiber optic terminus for virtually every high-performance fiber optic system in use today and we are on the design and standards committees creating fiber optic interconnect solutions for tomorrow's mission-critical applications.

Fiber Optic Costs and Benefits

When evaluating the costs and benefits of moving to fiber, it is important to adopt both a short and long term view. In the short term, it is arguably less expensive to simply continue using copper cabling to meet an incremental expansion of data communication needs. This avoids the expense of adding the transmitters, converters, repeaters, connectors, termini, receivers and so on needed for integrating optical fiber into an existing electronic system. Taking the long view, investing in the conversion to fiber optics often makes good sense, especially given the performance benefits—EMI immunity, security, weight reduction, bandwidth, etc.—as well as cost of ownership factors such as reduced cable maintenance costs and ease of installation.

Introduction to Crimp Contacts Series 80 Mighty Mouse



About Our Series 80 Mighty Mouse Size #23 Crimp Contacts

Like all high-performance crimp contact systems, Series 80 Mighty Mouse contacts are terminated to wire using precision crimp tools, and are then snapped into place by hand or with a hand held insertion tool. Damaged or miswired contacts may be removed from the connector using special extraction tools. Although the connectors are supplied with a full complement of contacts, extra contacts are commonly purchased as spares or to use for quality assurance purposes, such as crimp tensile tests. Coaxial contacts are also typically ordered separately, as customers prefer to specify the exact performance values for these specialized shielded contacts.

Mighty Mouse contacts conform to the requirements of Aerospace Standard AS39029. This SAE specification defines the design, dimensions and performance of contacts used in aerospace grade electrical connectors. The "general specification" covers a variety of contacts including thermocouple, hermetic, coaxial and triaxial types. The "slash sheets" contain dimensions and other information for specific types of contacts. Each contact is assigned a Basic Identification Number (BIN), a non-significant three digit code corresponding to the color code on the contacts. Series 80 Size #23 and size #20HD contacts conform to AS39029 requirements, but are not covered by a slash sheet. Size #20, #16 and size #12 contacts are standard AS39029 contacts.

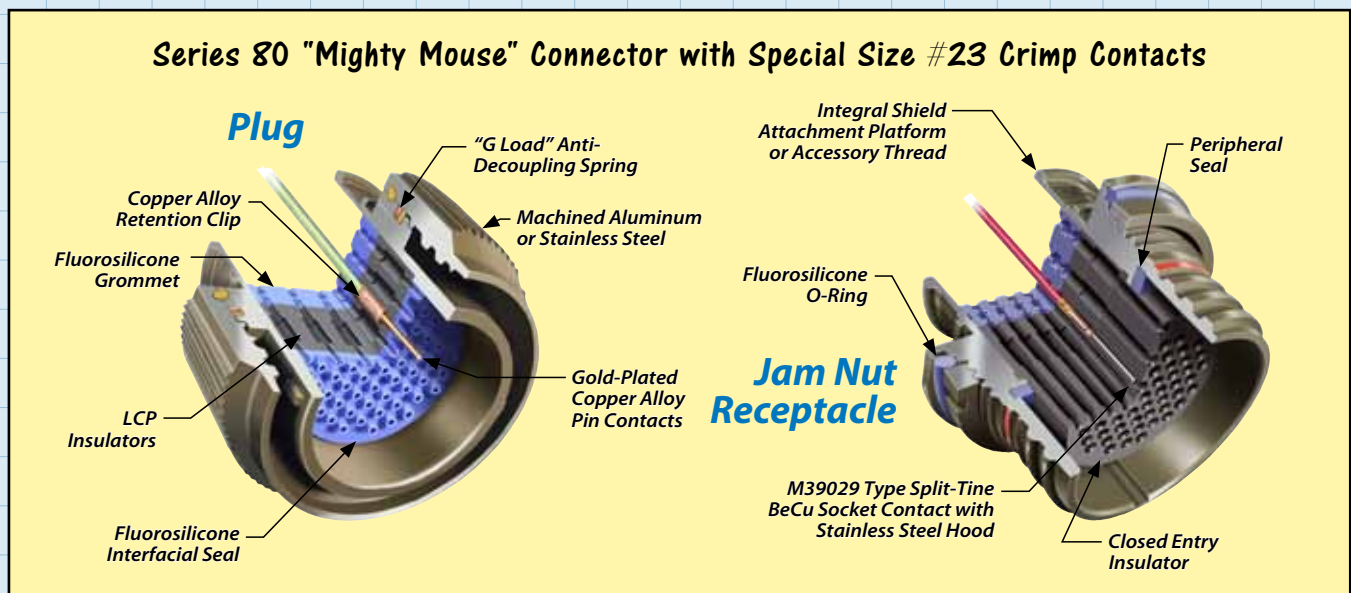

About Thermocouple and Other Special Purpose Contacts

Glenair produces a wide range of special purpose contacts including high power and high ampacity contacts, pneumatic contacts, PC Tail contacts for board terminations and thermocouple contacts for use in temperature measuring applications. We also produce all the small accessory items, such as sealing plugs, that make us a convenient one-stop-shopping destination for users of high-performance Mil-Spec and commercial connectors and contacts.

We invite our customers to take advantage of the breadth and depth of our contact product line, especially in terms of its high-availability and our willingness to engineer unique and special-purpose contact solutions for virtually any interconnect challenge.



Connector and Contact Glossary of Useful Terms

Barrel - (Conductor Barrel) - The section of the terminal, splice or contact that accommodates the stripped conductor.

BIN (Basic Identification Number) - color bands on the crimp barrel of a contact to identify contact part number. Each BIN code corresponds to only one slash sheet, thus identifying the complete M39029/XX- part number.

Closed entry - A contact or contact cavity design in the insert or body of the connector which limits the size or position of the mating contact or printed circuit board to a predetermined dimension.

Coaxial contact - A contact having two conducting surfaces, a center contact and a coaxially placed sleeve

Contact - The conductive element in a connector that makes actual contact, for the purpose of transferring electrical energy.

Contact area - The area in contact between two conductors, two contacts, or a conductor and a contact permitting the flow of electricity.

Contact arrangement - The number, spacing and arrangement of contacts in a connector.

Contact resistance - Electrical resistance of a pair of engaged contacts. Resistance may be measured in ohms or millivolt drop at a specified current over the engaged contacts.

Contact retainer - A device either on the contact or in the insert to retain the contact in an insert or body.

Contact retention - The axial load in either direction which a contact can withstand without being dislodged from its normal position within an insert or body.

Contact size - An assigned number denoting the size of the contact engaging end.

Contact shoulder - The flanged portion of a contact which limits its travel into the insert.

Crimp - The physical compression (deformation) of a contact barrel around a conductor in order to make an electrical connection.

Crimp contact - A contact, pin or socket, whose back portion (wire barrel) is a hollow cylinder into which a stripped wire (conductor) is inserted. The sidewalls of the wire barrel are then mechanically compressed (uniformly deformed) using a crimping tool to captivate the conductor.

Crimping dies - Portion of the crimping tool that shapes the crimp.

Crimping tool - Mechanism used for crimping.

Depth of Crimp - The distance the indenter penetrates into the barrel.

Die Closure - The gap between indenter dies at full handle closure. Usually defined by Go/No-Go dimensions.

Indenter - That part of a crimping die, usually the moving part, which indents or compresses the contact barrel.

Inspection hole - A hole placed at the bottom end of a contact wire barrel to permit visual inspection to see that the conductor has been inserted to the proper depth in the barrel prior to crimping.

Installing tool - A device used to install contacts into a connector. A device used to install taper pins into taper pin receptacles.

Locator - Device for positioning terminals, splices, or contacts into crimping dies, positioner, or turret heads.

Milivolt drop test - A test designed to determine the voltage loss due to resistance of a crimped joint.

Pin contact - A contact having an engagement end that enters the socket contact.

Connector and Contact Glossary of Useful Terms



Plating - The overlaying of a thin coating of metal on metallic components to improve conductivity, provide for easy soldering or prevent rusting or corrosion.

Positioner - A device when attached to a crimping tool locates the contact in the correct position.

Power contact - Type of contact used in multi-contact connectors to support the flow of rated current.

Pull-out force - Force necessary to separate a conductor from a contact or terminal, or a contact from a connector, by exerting a tensile pull.

Radio frequency contact (RF contact) - An impedance matched shielded contact.

Range, wire - The sizes of conductors accommodated by a particular barrel. Also the diameters of wires accommodated by a sealing grommet.

Removal tool - A device used to remove a contact from a connector. A device used to remove a taper pin from a taper pin receptacle.

Sealing plug - A plug which is inserted to fill an unoccupied contact aperture in a connector insert. Its function is to seal all unoccupied apertures in the insert, especially in environmental connectors.

Shielded contact - A contact which carries alternating current and is shielded from unwanted signals (RFI and EMI).

Socket contact - A contact having an engagement end that will accept entry of a pin contact.

Solderless connection - The joining of two metals by pressure means without the use of solder, braze, or any method requiring heat.

Strip - To remove insulation from a conductor. (See details elsewhere in technical section of this cat.)

Thermocouple contact - Contact of special material used in connectors employed in thermocouple applications. Material often used are iron, constantan, copper, chromel, alumel and others.

Turret Head - A device that contains more than one locator which can be indexed by rotating a circular barrel, and when attached to a crimping tool, positions the contact.

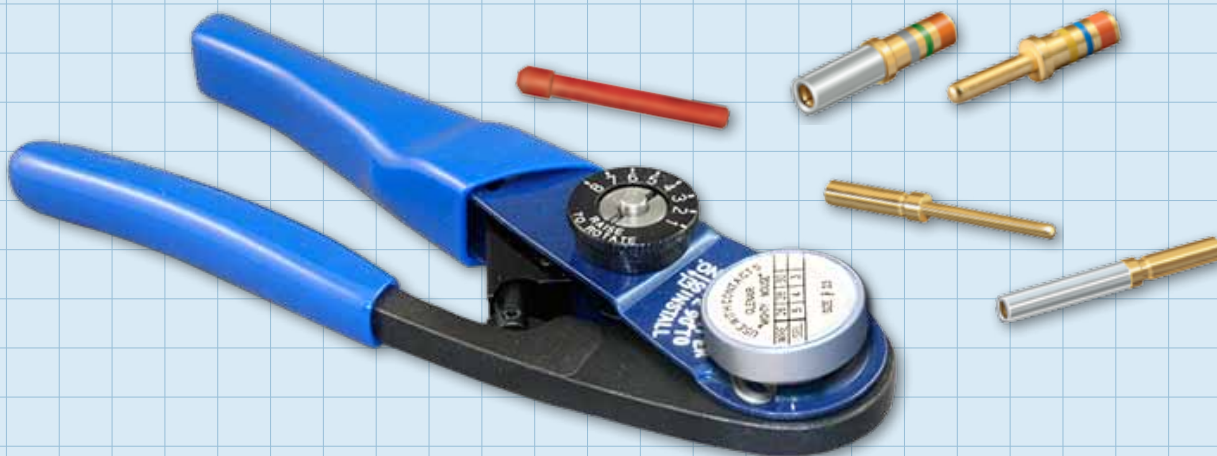

Tired of Cooling Your Heels?

Glenair Rapid-Response Contact Manufacturing and Same-Day Stocking Saves You Time, Money and Hassle

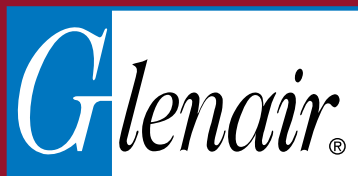

1211 Air Way

Glendale, California 91201-2497

Telephone: 818-247-6000 · Facsimile: 818-500-9912 · E-mail: sales@glenair.com

United States · United Kingdom · Germany · Nordic · France · Italy · Spain · Japan

www.glenair.com

SAE-AS39029 QPL

High Performance Pin and Socket Crimp Contacts

A

Outstanding Product Availability

Glenair brings a new perspective to the supply of Mil-Spec crimp contacts: *High Availability!* Whether you need a standard duty socket for a MIL-DTL-28840 connector or an extended duty pin for MIL-DTL-38999 Series III we have got you covered with products that are always in stock—with no dollar or quantity minimums.

In addition to the broadest selection and availability, Glenair also delivers outstanding interconnection compatibility. Glenair QPL SAE-AS39029 contacts are guaranteed to mate properly and perform at the upper limits of application and specification requirements.

Errata

Catalog contents—including part numbers, materials and dimensions—are accurate to the best of our ability when we go to print. When errors or mistakes are brought to our attention, corrected content is posted immediately to www.glenair.com.

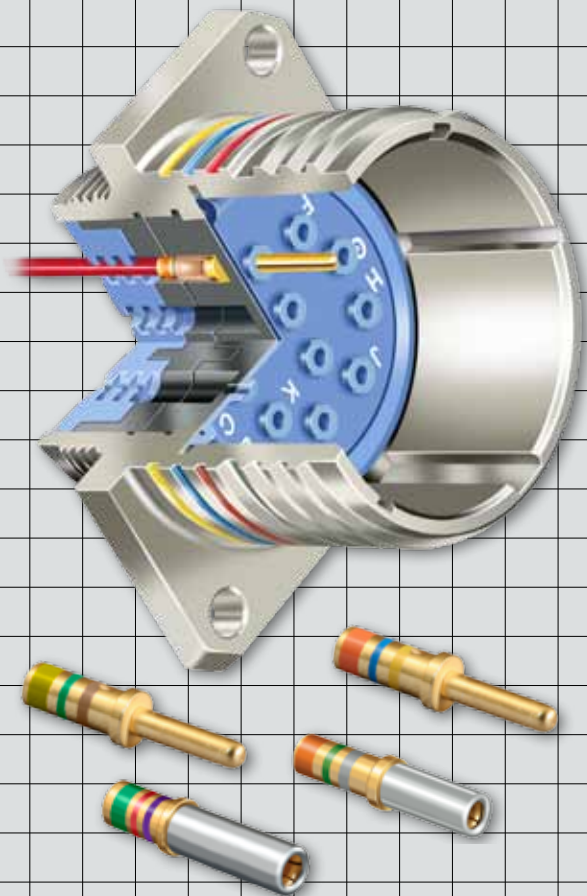

- ◆ Qualified to SAE-AS39029 on Dozens of Contacts—and Growing!
- ◆ Same Day Inventory on Popular and Hard-to-Find Styles
- ◆ Highest Quality Materials Including Enhanced Durability Plating
- ◆ Fully Intermatable with Equivalent AS39029 QPL Contacts

A

Military Part Number	Glenair Part Number	Contact Size	Wire Accommodation	Pin / Socket	BIN Color Striping			Product Page
M39029/56-348	850-001-22-348	22	22-28 AWG	Socket	Orange	Yellow	Grey	A-6
M39029/56-351	850-001-20-351	20	20-24 AWG	Socket	Orange	Green	Brown	
M39029/56-352	850-001-16-352	16	16-20 AWG	Socket	Orange	Green	Red	
M39029/56-353	850-001-12-353	12	12-14 AWG	Socket	Orange	Green	Orange	
M39029/56-527	850-001-10-527	10	10 AWG	Socket	Green	Red	Violet	
M39029/57-354	850-003-22-354	22	22-28 AWG	Socket	Orange	Green	Yellow	A-8
M39029/57-357	850-003-20-357	20	20-24 AWG	Socket	Orange	Green	Violet	
M39029/57-358	850-003-16-358	16	16-20 AWG	Socket	Orange	Green	Grey	
M39029/57-359	850-003-12-359	12	12-14 AWG	Socket	Orange	Green	White	
M39029/58-360	850-002-22-360	22	22-28 AWG	Pin	Orange	Blue	Black	A-10
M39029/58-363	850-002-20-363	20	20-24 AWG	Pin	Orange	Blue	Orange	
M39029/58-364	850-002-16-364	16	16-20 AWG	Pin	Orange	Blue	Yellow	
M39029/58-365	850-002-12-365	12	12-14 AWG	Pin	Orange	Blue	Green	
M39029/58-528	850-002-10-528	10	10 AWG	Pin	Green	Red	Grey	
M39029/63-368	850-021-20-368	20	20-24 AWG	Socket	Orange	Blue	Grey	A-12
M39029/64-369	850-022-20-369	20	20-24 AWG	Pin	Orange	Blue	White	A-13

BIN Color Coding

0 BLACK	1 BROWN	2 RED	3 ORANGE	4 YELLOW	5 GREEN	6 BLUE	7 VIOLET	8 GREY	9 WHITE
------------	------------	----------	-------------	-------------	------------	-----------	-------------	-----------	------------

SAE-AS39029 Crimp Contact Selection Guide



AS39029

A

Military Part Number	Glenair Part Number	Contact Size	Wire Accommodation	Pin / Socket	BIN Color Striping			Product Page
M39029/83-450	850-004-20-450	20	22-26 AWG	Pin	Yellow	Green	Black	A-14
M39029/83-451	850-004-20-451	20	28-32 AWG	Pin	Yellow	Green	Brown	
M39029/83-508	850-004-20-508	20	20-24 AWG	Pin	Green	Black	Grey	
M39029/84-452	850-005-20-452	20	22-26 AWG	Socket	Yellow	Green	Red	A-16
M39029/84-453	850-005-20-453	20	28-32 AWG	Socket	Yellow	Green	Orange	
M39029/84-509	850-005-20-509	20	20-24 AWG	Socket	Green	Black	White	
M39029/106-614	850-006-22-614	22	22-28 AWG	Socket	Blue	Brown	Yellow	A-18
M39029/106-615	850-006-20-615	20	20-24 AWG	Socket	Blue	Brown	Green	
M39029/106-616	850-006-16-616	16	16-20 AWG	Socket	Blue	Brown	Blue	
M39029/106-617	850-006-12-617	12	12-14 AWG	Socket	Blue	Brown	Violet	
M39029/106-618	850-006-10-618	10	10 AWG	Socket	Blue	Brown	Grey	
M39029/107-620	850-007-22-620	22	22-28 AWG	Pin	Blue	Red	Black	A-20
M39029/107-621	850-007-20-621	20	20-24 AWG	Pin	Blue	Black	Brown	
M39029/107-622	850-007-16-622	16	16-20 AWG	Pin	Blue	Red	Red	
M39029/107-623	850-007-12-623	12	12-14 AWG	Pin	Blue	Red	Orange	
M39029/107-624	850-007-10-624	10	10 AWG	Pin	Blue	Red	Yellow	

BIN Color Coding									
0 BLACK	1 BROWN	2 RED	3 ORANGE	4 YELLOW	5 GREEN	6 BLUE	7 VIOLET	8 GREY	9 WHITE

Test	Performance Specifications	
Current Rating	<i>(meets SAE-AS39029, paragraph 3.5.4.1)</i>	
	Contact Size	Maximum Amps <i>Crimp</i>
	22D	5
	20	7.5
	16	13
	12	23
Contact Millivolt Drop	Contact Size	Maximum Millivolt Drop <i>Crimp</i>
	22D	73
	20	55
	16	49
	12	42
	10	33

Tensile Strength	Axial Load (Pounds)					Axial Load (Pounds)				
	Wire Size	Silver Tin-Plated Copper Wire		Nickel-Plated Copper Wire		Wire Size	Silver Tin-Plated Copper Wire		Nickel-Plated Copper Wire	
		Initial Condition Values	Thermal Condition Values	Initial Condition Values	Thermal Condition Values		Initial Condition Values	Thermal Condition Values	Initial Condition Values	Thermal Condition Values
	0000	875	787.5	785	706.5	12	110	93.0	100	85.0
	00	750	675.0	675	607.5	14	70	61.0	60	53.0
	0	700	630.0	630	567.0	16	50	45	37	33
	1	650	585.0	585	526.5	20	20	14	19	14.3
	2	550	495.0	495	445.5	22	12	7.5	8	6.0
	4	400	360.0	360	324.0	24	8	6	6	4.5
	6	300	270.0	270	243.0	26	5	4.0	3	2.5
	8	220	198.0	200	180.0	28	3	2.25	1	1.50
	10	150	135.0	135	121.5	30	1.5	1.13	1.5	1.13

CONTACT MATERIALS AND SPECIFICATIONS

Component	Material	Notes
Pin Contact	Beryllium copper alloy per ASTM B197, 50 microinches gold plated per ASTM B488 Type II Code C Class 1,27 over nickel plate per QQ-N-290 Class 2, 30-150 microinches	Approved for Space Flight
Socket Contact	Beryllium copper alloy per ASTM B197, 50 microinches gold plated per ASTM B488 Type II Code C Class 1,27 over nickel plate per QQ-N-290 Class 2, 30-150 microinches.	Approved for Space Flight
Socket Contact Hood	Stainless steel, passivated per AMS-QQ-P-35	Approved for Space Flight

Contact Performance Specifications



AS39029

A

Test	Performance Specifications
Durability	<i>(meets SAE-AS39029, paragraph 3.5.9)</i> No electrical or mechanical defects after 500 cycles of engagement and disengagement
Contact Retention	<i>(meets MIL-DTL-38999, paragraph 3.23)</i> The axial displacement of the contact shall not exceed .012 inch (0.30 mm). No damage to contacts or inserts shall result.
Pin Engagement End	<i>(meets SAE-AS39029 paragraph 3.4.1)</i> Unless otherwise specified, the mating end of all contacts (except size 22 and smaller) shall be formed with an approximate spherical radius.
Permeability	<i>(meets SAE-AS39029, paragraph 3.5.1)</i> When tested as specified in paragraph 4.7.2, the relative magnetic permeability of the contact shall be no greater than 2.0.
Vibration	<i>(meets SAE-AS39029, paragraph 3.5.10)</i> When contacts are tested as specified in paragraph 4.7.11, there shall be no electrical discontinuity of 1 microsecond or greater. There shall be no defects detrimental to the mechanical or electrical performance.
Salt Spray (corrosion)	<i>(meets SAE-AS39029, paragraph 3.5.12)</i> When tested as specified in 4.7.13, mated contacts shall withstand 48 hours of salt spray conditioning without defects detrimental to the mechanical or electrical performance.
Temperature life	<i>(meets SAE-AS39029, paragraph 3.5.13)</i> When tested as specified in paragraph 4.7.14, mated contacts shall withstand temperature conditioning for 1,000 hours without defects detrimental to mechanical or electrical performance. There shall be no diffusion/migration of the base metal through the contact outer plating. Class A - Maximum operating temperature +125°C. per paragraph 1.2.2
Dielectric withstanding voltage	<i>(meets SAE-AS39029, paragraph 3.5.19)</i> When tested as specified in paragraph 4.7.20, crimped contacts shall show no evidence of breakdown or flashover.
Workmanship	<i>(meets SAE-AS39029, paragraph 3.7)</i> Contacts shall be processed in such a manner as to be uniform in quality and shall be free from foreign material and burrs or sharp corners that might damage the connector or affect mating of the contacts. Burrs and sharp edges shall be removed 0.005 inch maximum.

D38999
 Ser. I, III, IV

Standard Socket Crimp Contact for MIL-DTL-38999 Series I, III and IV Connectors

A

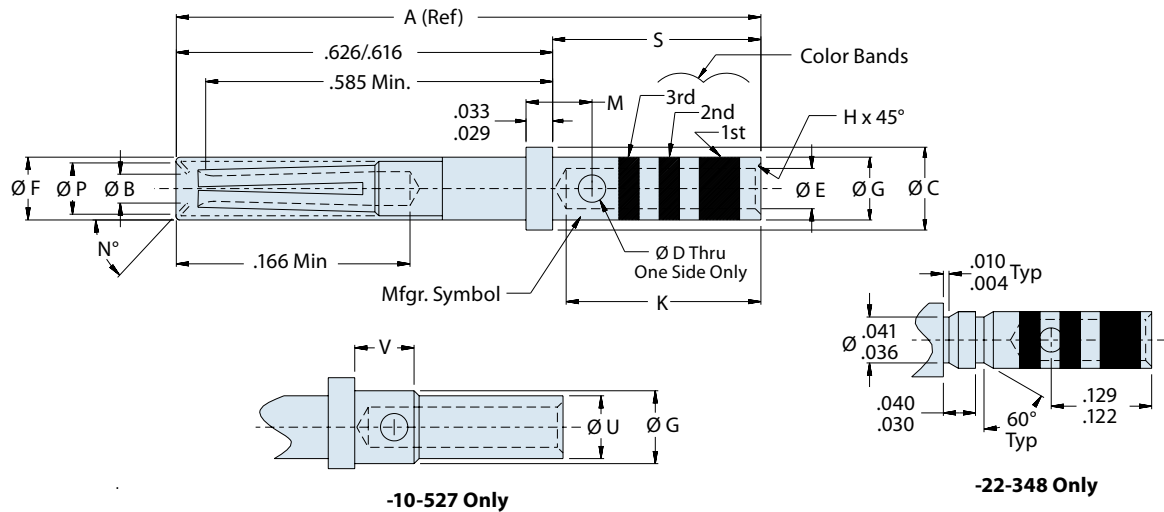

Mating End Size	Wire Accomodation	Military Part Number	Glenair Part Number
22	22-28 AWG	M39029/56-348	850-001-22-348
20	20-24 AWG	M39029/56-351	850-001-20-351
16	16-20 AWG	M39029/56-352	850-001-16-352
12	12-14 AWG	M39029/56-353	850-001-12-353
10	10 AWG	M39029/56-527	850-001-10-527

Material and Finish*

Pin Contact: Copper Alloy/Gold Plated
 Socket Contact: Copper Alloy/Gold Plated
 Socket Contact Hood: Passivated Stainless Steel

* See pages A-4 and A-5 for detailed material specifications

**M39029/56
850-001
Standard Duty Electrical Socket Contact**



AS39029

A

TABLE I: CONTACT DIMENSIONS

Size	Part Number	Military Number	A (ref)	Ø B Min.	Ø C	Ø D	Ø E	Ø F Max	Ø G	Ø H	K Min
22	850-001-22-348	M39029/56-348	.855	.031	.062 .060	.022 .018	.0355 .0335	.062	.048 .046	.005 .003	.141
20	850-001-20-351	M39029/56-351		.0415	.094 .091	.032 .026	.048 .046	.078	.070 .068	.010 .005	.209
16	850-001-16-352	M39029/56-352		.064	.130 .127	.042 .036	.068 .066	.113	.103 .101	.010 .005	.209
12	850-001-12-353	M39029/56-353		.0955	.182 .179	.042 .036	.102 .098	.161	.151 .148	.016 .005	.209
10	850-001-10-527	M39029/56-527	1.021	.1265	.242 .238	.052 .046	.140 .134	.215	.213 .207	.016 .005	.385 .355

TABLE I (Continued): CONTACT DIMENSIONS

Size	Part Number	Military Number	M	N°	Ø P Min	S	Ø U	V	Color Bands		
									1st	2nd	3rd
22	850-001-22-348	M39029/56-348	-	50° 44°	.047	.237 .231	-	-	Orange	Yellow	Grey
20	850-001-20-351	M39029/56-351	.078 .072	47° 40°	.053		-	-	Orange	Green	Brown
16	850-001-16-352	M39029/56-352	.088 .082	47° 40°	.084		-	-	Orange	Green	Red
12	850-001-12-353	M39029/56-353	.088 .082	47° 40°	.118		-	-	Orange	Green	Orange
10	850-001-10-527	M39029/56-527	.115 .108	Full R	.146	.405 .395	.183 .177	.121 .111	Green	Red	Violet

TABLE II: TOOL COMPATIBILITY

Size	Part Number	Military Number	AWG Handling	Crimp Tool	Positioner	Insertion Tool	Extraction Tool
22	850-001-22-348	M39029/56-348	22, 24, 26, 28	M22520/2-01 M22520/7-01	M22520/2-07 M22520/7-05	M81969/14-01 M81969/8-01	M81969/14-01 M81969/8-02
20	850-001-20-351	M39029/56-351	20, 22, 24	M22520/7-01 M22520/2-01 M22520/1-01	M22520/7-08 M22520/2-10 M22520/1-04 (Red)	M81969/8-05 M81969/14-02	M81969/8-06 M81969/14-02
16	850-001-16-352	M39029/56-352	16, 18, 20	M22520/1-01 M22520/7-01	M22520/1-04 (Blue) M22520/7-04	M81969/8-07 M81969/14-03	M81969/8-08 M81969/14-03
12	850-001-12-353	M39029/56-353	12, 14	M22520/1-01	M22520/1-04 (Yellow)	M81969/8-09 M81969/14-04	M81969/8-10 M81969/14-04
10	850-001-10-527	M39029/56-527	10	Daniels 1716P-1	Daniels 1716P-1	M81969/14-05 and M81969/8-11	M81969/14-05 and M81969/8-12

D38999
Series II

M24308

M55302

M83733

Standard Socket Crimp Contact for MIL-DTL-38999 Series II Connectors

A

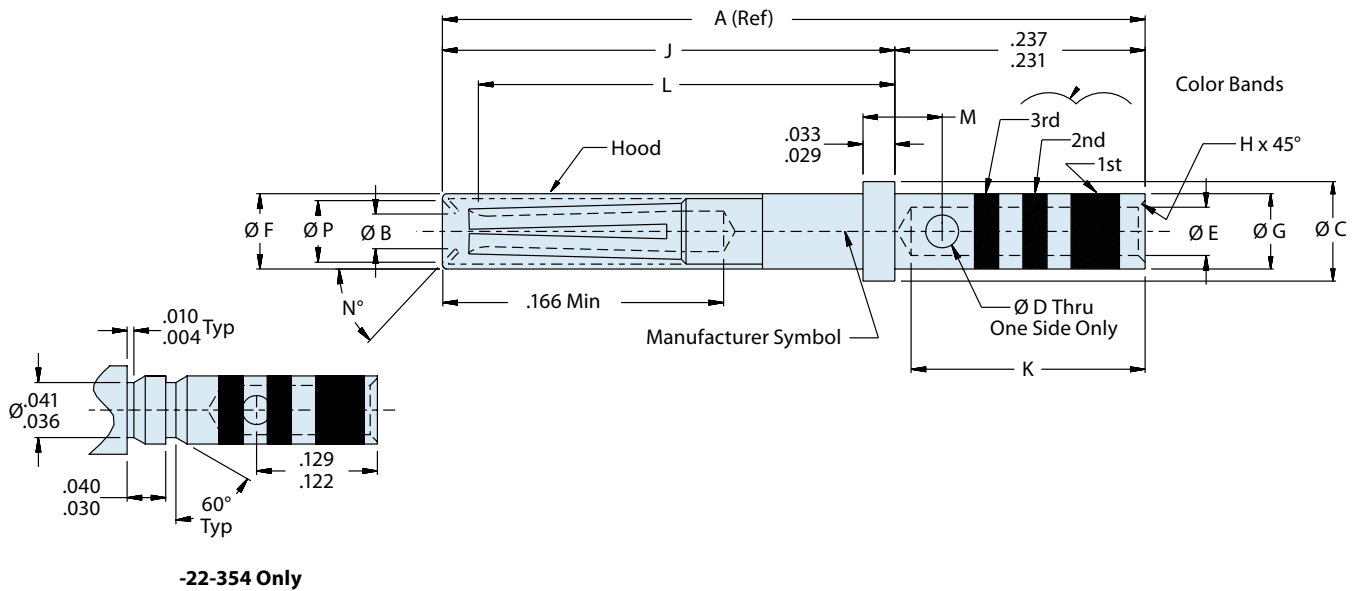

Mating End Size	Wire Accomodation	Military Part Number	Glenair Part Number
22	22-28 AWG	M39029/57-354	850-003-22-354
20	20-24 AWG	M39029/57-357	850-003-20-357
16	16-20 AWG	M39029/57-358	850-003-16-358
12	12-14 AWG	M39029/57-359	850-003-12-359

Material and Finish*

Pin Contact: Copper Alloy/Gold Plated
 Socket Contact: Copper Alloy/Gold Plated
 Socket Contact Hood: Passivated Stainless Steel

* See pages A-4 and A-5 for detailed material specifications

M39029/57
850-003
Standard Duty Electrical Socket Contact



AS39029

A

TABLE I: CONTACT DIMENSIONS

Size	Part Number	Military Number	A (ref)	ø B Min.	ø C	ø D	ø E	ø F Max.	ø G	H	J
22	850-003-22-354	M39029/57-354	.518	.031	.062 .060	.022 .018	.0355 .0335	.062	.048 .046	.005 .003	.289 .279
20	850-003-20-357	M39029/57-357	.518	.0415	.094 .091	.032 .026	.048 .046	.078	.070 .068	.010 .005	.289 .279
16	850-003-16-358	M39029/57-358	.518	.064	.130 .127	.042 .036	.068 .066	.113	.103 .101	.010 .005	.289 .279
12	850-003-12-359	M39029/57-359	.518	.0955	.182 .179	.042 .036	.102 .098	.161	.151 .148	.016 .005	.289 .279

TABLE I (Continued): CONTACT DIMENSIONS

Size	Part Number	Military Number	K Min.	L Min.	M	N°	ø P Min.	Color Bands		
								1st	2nd	3rd
22	850-003-22-354	M39029/57-354	.141	.248	-	50 44	.047	Orange	Green	Yellow
20	850-003-20-357	M39029/57-357	.209	.248	.078 .072	47 28	.053	Orange	Green	Violet
16	850-003-16-358	M39029/57-358	.209	.248	.088 .082	47 28	.084	Orange	Green	Gray
12	850-003-12-359	M39029/57-359	.209	.248	.088 .082	47 28	.118	Orange	Green	White

TABLE II: TOOL COMPATIBILITY

Size	Part Number	Military Number	AWG Handling	Crimp Tool	Positioner	Insertion Tool	Extraction Tool
22	850-003-22-354	M39029/57-354	22, 24, 26, 28	M22520/2-01 M22520/7-01	M22520/2-06 M22520/7-06	M81969/14-01 M81969/8-01	M81969/14-01 M81969/8-02
20	850-003-20-357	M39029/57-357	20, 22, 24	M22520/7-01 M22520/2-01 M22520/1-01	M22520/7-08 M22520/2-10 M22520/1-04 (Red)	M81969/8-05 M81969/14-02	M81969/8-06 M81969/14-02
16	850-003-16-358	M39029/57-358	16, 18, 20	M22520/1-01 M22520/7-01	M22520/1-04 (Blue) M22520/7-04	M81969/8-07 M81969/14-03	M81969/8-08 M81969/14-03
12	850-003-12-359	M39029/57-359	12, 14	M22520/1-01	M22520/1-04 (Yellow)	M81969/8-09 M81969/14-04	M81969/8-10 M81969/14-04

D38999
 Ser. I, II, III, IV

M24308
M55302
M83733
Standard Pin Crimp Contact for MIL-DTL-38999 Series I, II, III and IV Connectors
A

Mating End Size	Wire Accomodation	Military Part Number	Glenair Part Number
22	22-28 AWG	M39029/58-360	850-002-22-360
20	20-24 AWG	M39029/58-363	850-002-20-363
16	16-20 AWG	M39029/58-364	850-002-16-364
12	12-14 AWG	M39029/58-365	850-002-12-365
10	10 AWG	M39029/58-528	850-002-10-528

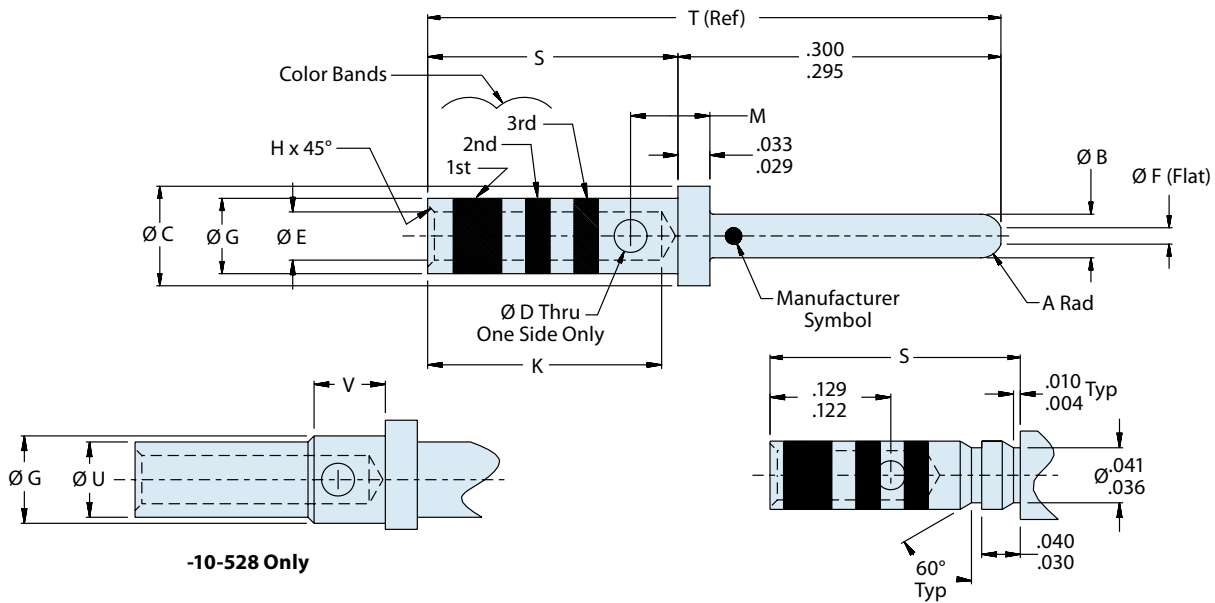
Material and Finish*

Pin Contact: Copper Alloy/Gold Plated
 Socket Contact: Copper Alloy/Gold Plated
 Socket Contact Hood: Passivated Stainless Steel

* See pages A-4 and A-5 for detailed material specifications

M39029/58
850-002
Standard Duty Electrical Pin Contact



AS39029

A

TABLE I: CONTACT DIMENSIONS

Size	Part Number	Military Number	A (rad)	ø B Min.	ø C	ø D	ø E	ø F	ø G	H
22	850-002-22-360	M39029/58-360	.020 .010	.0305 .0295	.062 .060	.022 .018	.0355 .0335	.011 max	.048 .046	.005 .003
20	850-002-20-363	M39029/58-363	.025 .020	.041 .039	.094 .091	.032 .026	.048 .046	.015 max	.070 .068	.010 .005
16	850-002-16-364	M39029/58-364	.025 .020	.0635 .0616	.130 .127	.042 .036	.068 .066	.030 .011	.103 .101	.010 .005
12	850-002-12-365	M39029/58-365	.025 .020	.095 .093	.182 .179	.042 .036	.102 .098	.062 .043	.151 .148	.016 .005
10	850-002-10-528	M39029/58-528	.025 .020	.126 .124	.242 .238	.052 .040	.140 .134	.094 .074	.213 .207	.016 .005

TABLE I (Continued): CONTACT DIMENSIONS

Size	Part Number	Military Number	K Min.	M	S	T (Ref)	ø U	V	Color Bands		
									1st	2nd	3rd
22	850-002-22-360	M39029/58-360	.141	–	.237 .231	.531	–	–	Orange	Blue	Black
20	850-002-20-363	M39029/58-363	.209	.078 .072	.237 .231	.531	–	–	Orange	Blue	Orange
16	850-002-16-364	M39029/58-364	.209	.088 .082	.237 .231	.531	–	–	Orange	Blue	Yellow
12	850-002-12-365	M39029/58-365	.209	.088 .082	.237 .231	.531	–	–	Orange	Blue	Green
10	850-002-10-528	M39029/58-528	.355	.115 .108	.405 .395	.698	.183 .177	.121 .111	Green	Red	Gray

TABLE II: TOOL COMPATIBILITY

Size	Part Number	Military Number	AWG Handling	Crimp Tool	Positioner	Insertion Tool	Extraction Tool
22	850-002-22-360	M39029/58-360	22, 24, 26, 28	M22520/2-01 M22520/7-01	M22520/2-09 M22520//7-07	M81969/14-01 M81969/8-01	M81969/14-01 M81969/8-02
20	850-002-20-363	M39029/58-363	20, 22, 24	M22520/7-01 M22520/2-01 M22520/1-01	M22520/7-08 M22520/2-10 M22520/1-04 (Red)	M81969/8-05 M81969/14-02	M81969/8-06 M81969/14-02
16	850-002-16-364	M39029/58-364	16, 18, 20	M22520/1-01 M22520/7-01	M22520/1-04 (Blue) M22520/7-04	M81969/8-07 M81969/14-03	M81969/8-08 M81969/14-03
12	850-002-12-365	M39029/58-365	12, 14	M22520/1-01	M22520/1-04 (Yellow)	M81969/8-09 M81969/14-04	M81969/8-10 M81969/14-04
10	850-002-10-528	M39029/58-528	10	Daniels 1716P-1	Daniels 1716P-1	M81969/14-05 and M81969/8-11	M81969/14-05 and M81969/8-12

M24308

Standard Socket Crimp Contact for MIL-DTL-24308



Mating End Size	Wire Accomodation	Military Part Number	Glenair Part Number
20	20-24 AWG	M39029/63-368	850-021-20-368

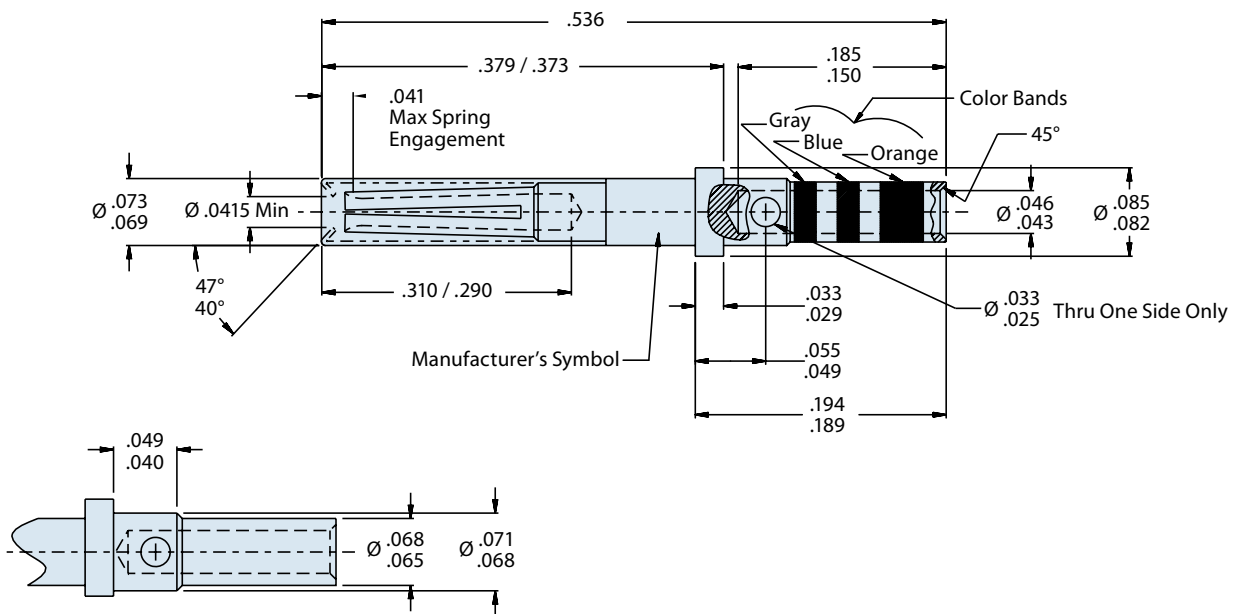

Material and Finish*

Pin Contact: Copper Alloy/Gold Plated

Socket Contact: Copper Alloy/Gold Plated

Socket Contact Hood: Passivated Stainless Steel

*See pages A-4 and A-5 for detailed material specifications

Tools

Crimp Tool: M22520/2-01

Positioner: M22520/2-08

Insertion/Extraction Tools: M81969/14-02 or M81969/1-02

**M39029/64
850-022
Standard Duty Electrical Pin Contact**



AS39029

M24308

Standard Pin Crimp Contact for MIL-DTL-24308



Mating End Size	Wire Accomodation	Military Part Number	Glenair Part Number
20	20-24 AWG	M39029/64-369	850-022-20-369

A

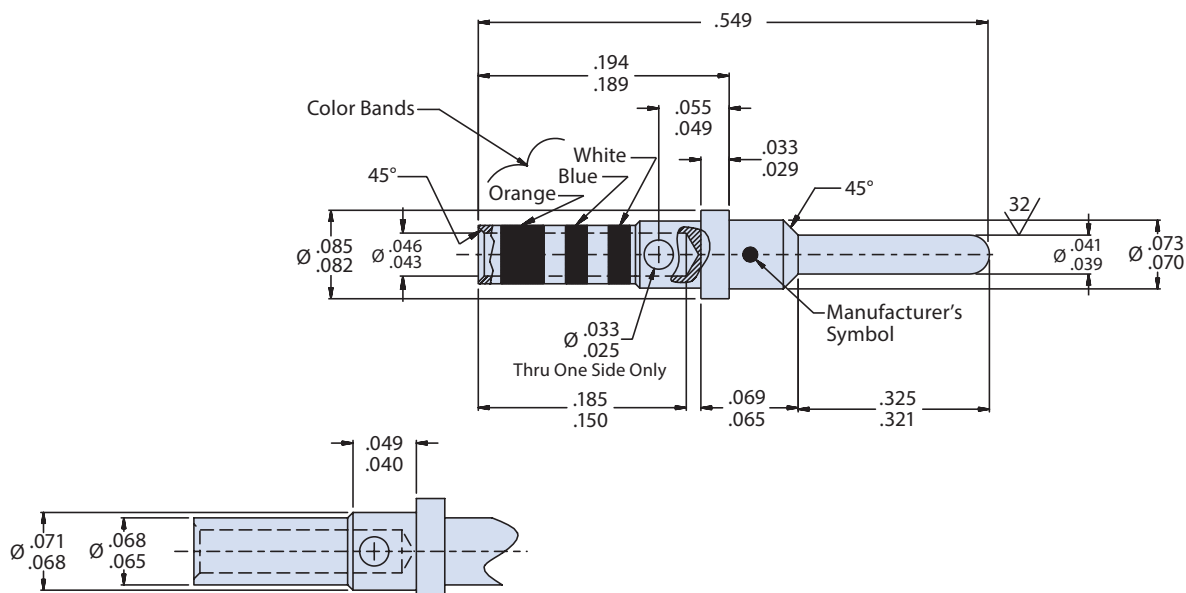

Material and Finish*

Pin Contact: Copper Alloy/Gold Plated
 Socket Contact: Copper Alloy/Gold Plated
 Socket Contact Hood: Passivated Stainless Steel

*See pages A-4 and A-5 for detailed material specifications

Tools

Crimp Tool: M22520/2-01
 Positioner: M22520/2-08
 Insertion/Extraction Tools: M81969/14-02 or M81969/1-02

M28840

Standard Pin Crimp Contact for MIL-DTL-28840 Connectors

A



Mating End Size	Wire Accomodation	Military Part Number	Glenair Part Number
20	28-32 AWG	M39029/83-451	850-004-20-451
20	22-26 AWG	M39029/83-450	850-004-20-450
20	20-24 AWG	M39029/83-508	850-004-20-508

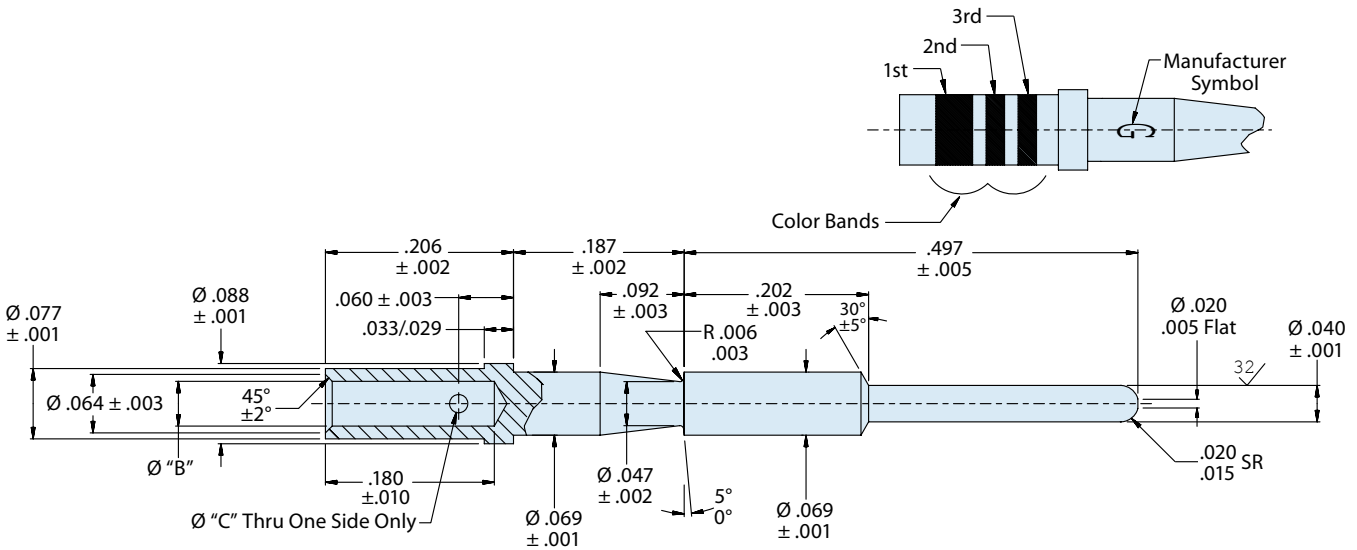

Material and Finish*

Pin Contact: Copper Alloy/Gold Plated
 Socket Contact: Copper Alloy/Gold Plated
 Socket Contact Hood: Passivated Stainless Steel

* See pages A-4 and A-5 for detailed material specifications

M39029/83
850-004
Standard Duty Electrical Pin Contact



AS39029

TABLE I: CONTACT DIMENSIONS

Size	Part Number	Military Number	Ø B	Ø C	Color Bands		
					1st	2nd	3rd
20	850-004-20-508	M39029/83-508	.050 .048	.032 .026	Green	Black	Grey
20	850-004-20-450	M39029/83-450	.0355 .0335	.032 .026	Yellow	Green	Black
20	850-004-20-451	M39029/83-451	.0200 .0180	.022 .018	Yellow	Green	Brown

A

TABLE II: TOOL COMPATIBILITY

Size	Part Number	Military Number	AWG Handling	Crimp Tool	Positioner	Insertion Tool	Extraction Tool
20	850-004-20-508	M39029/83-508	20, 22, 24	M22520/34-01	M22520/34-02	M81969/33-01	M81969/34-01
20	850-004-20-450	M39029/83-450	22, 24, 26	M22520/34-01	M22520/34-02	M81969/33-01	M81969/34-01
20	850-004-20-451	M39029/83-451	28, 30, 32	M22520/34-01	M22520/34-02	M81969/33-01	M81696/34-01

M28840

Standard Socket Crimp Contact for MIL-DTL-28840 Connectors
A

Mating End Size	Wire Accomodation	Military Part Number	Glennair Part Number
20	28-32 AWG	M39029/84-453	850-005-20-453
20	22-26 AWG	M39029/84-452	850-005-20-452
20	20-24 AWG	M39029/84-509	850-005-20-509

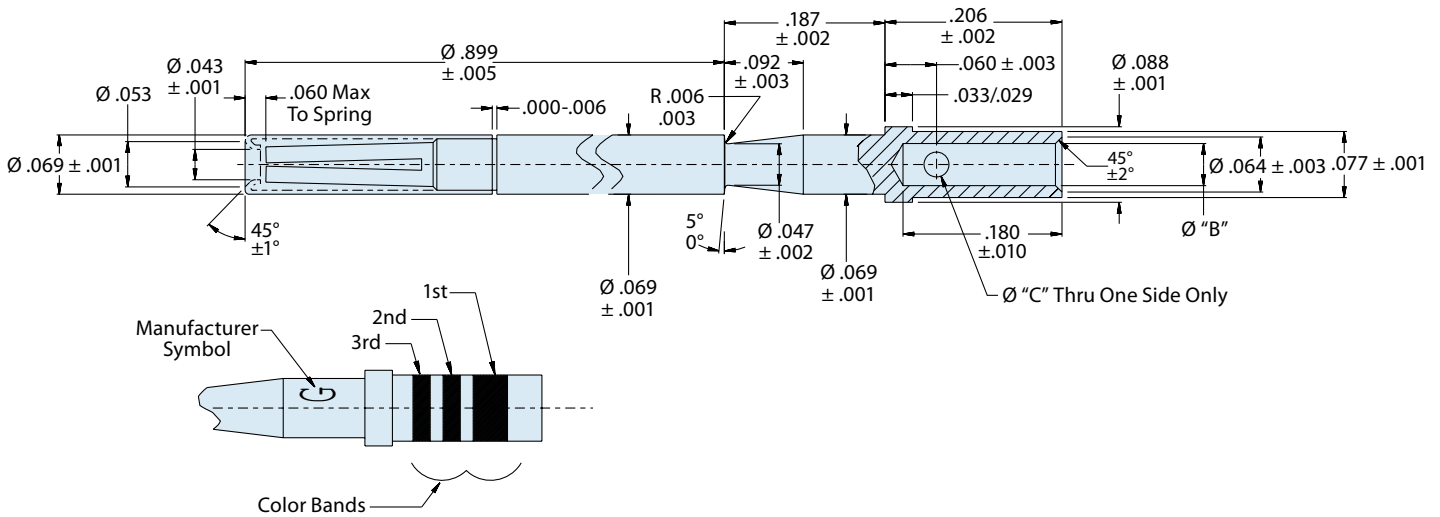
Material and Finish*

Pin Contact: Copper Alloy/Gold Plated
 Socket Contact: Copper Alloy/Gold Plated
 Socket Contact Hood: Passivated Stainless Steel

* See pages A-4 and A-5 for detailed material specifications

**M39029/84
850-005
Standard Duty Electrical Socket Contact**



AS39029

A

TABLE I: CONTACT DIMENSIONS

Size	Part Number	Military Number	Ø B	Ø C	Color Bands		
					1st	2nd	3rd
20	850-005-20-509	M39029/84-509	.050 .048	.032 .026	Green	Black	White
20	850-005-20-452	M39029/84-452	.0355 .0335	.032 .026	Yellow	Green	Red
20	850-005-20-453	M39029/84-453	.0200 .0180	.022 .018	Yellow	Green	Orange

TABLE II: TOOL COMPATIBILITY

Size	Part Number	Military Number	AWG Handling	Crimp Tool	Positioner	Insertion Tool	Extraction Tool
20	850-005-20-509	M39029/84-509	20, 22, 24	M22520/34-01	M22520/34-02	M81969/33-01	M81969/34-01
20	850-005-20-452	M39029/84-452	22, 24, 26	M22520/34-01	M22520/34-02	M81969/33-01	M81969/34-01
20	850-005-20-453	M39029/84-453	28, 30, 32	M22520/34-01	M22520/34-02	M81969/33-01	M81696/34-01

D38999
 Ser. I, III, IV

M29600
Extended Duty Socket Crimp Contact for MIL-DTL-38999 Series I, III and IV Connectors
A

Mating End Size	Wire Accomodation	Military Part Number	Glenair Part Number
22	22-28 AWG	M39029/106-614	850-006-22-614
20	20-24 AWG	M39029/106-615	850-006-20-615
16	16-20 AWG	M39029/106-616	850-006-16-616
12	12-14 AWG	M39029/106-617	850-006-12-617
10	10 AWG	M39029/106-618	850-006-10-618

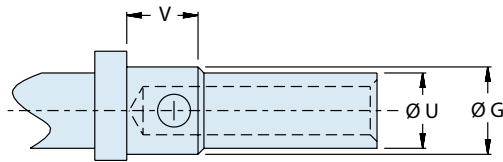
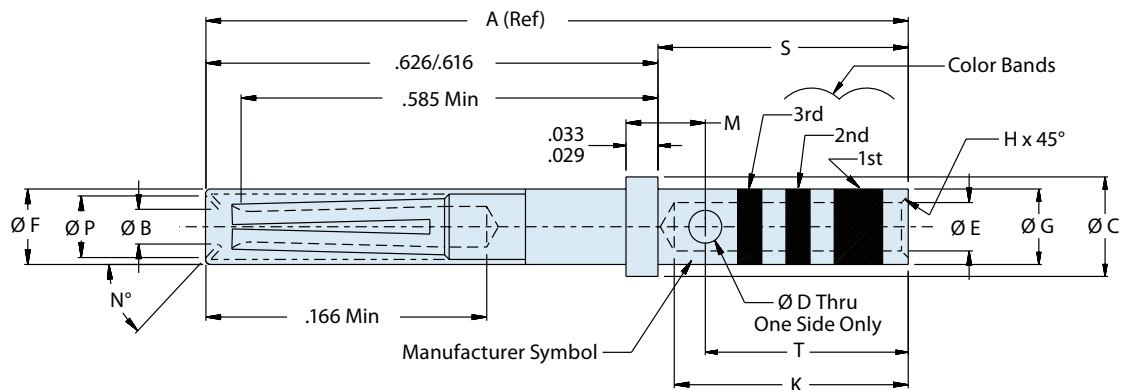
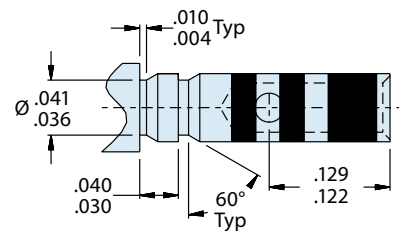
-10-618 Only

-22-614 Only
Material and Finish

Copper alloy, plated with 5 µinches gold over 45 µinches palladium alloy.
 Rated to 1500 cycles of durability.

39029/106
850-006
Extended Duty Electrical Socket Contact



AS39029

A

TABLE I: CONTACT DIMENSIONS

Size	Part Number	Military Number	A (ref)	ø B Min.	ø C	ø D	ø E	ø F Max.	ø G	ø H
22	850-006-22-614	M39029/106-614	.855	.031	.062 .060	.022 .018	.0355 .0335	.062	.048 .046	.005 .003
20	850-006-20-615	M39029/106-615		.0415	.094 .091	.032 .026	.048 .046	.078	.070 .068	.010 .005
16	850-006-16-616	M39029/106-616		.064	.130 .127	.042 .036	.068 .066	.113	.103 .101	.010 .005
12	850-006-12-617	M39029/106-617		.0955	.182 .179	.042 .036	.102 .098	.161	.151 .148	.016 .005
10	850-006-10-618	M39029/106-618	1.021	.1265	.242 .238	.052 .046	.140 .134	.215	.213 .207	.016 .005

TABLE I: (Continued) CONTACT DIMENSIONS

Size	Part Number	Military Number	K Min.	M	N°	ø P Min.	S	ø U	V	Color Bands		
										1st	2nd	3rd
22	850-006-22-614	M39029/106-614	.141	–	50° 44°	.047	.237 .231	–	–	Blue	Brown	Yellow
20	850-006-20-615	M39029/106-615	.209	.078 .072	47° 40°	.053		–	–	Blue	Brown	Green
16	850-006-16-616	M39029/106-616	.209	.088 .082	47° 40°	.084		–	–	Blue	Brown	Blue
12	850-006-12-617	M39029/106-617	.209	.088 .082	47° 40°	.118		–	–	Blue	Brown	Violet
10	850-006-10-618	M39029/106-618	.385 .355	.115 .108	Full Radius	.146		.405 .395	.183 .177	.121 .111	Blue	Brown

TABLE II: TOOL COMPATIBILITY

Size	Part Number	Military Number	AWG Handling	Crimp Tool	Positioner	Insertion Tool	Extraction Tool
22	850-006-22-614	M39029/106-614	22, 24, 26, 28	M22520/2-01 M22520/7-01	M22520/2-07 M22520/7-05	M81969/8-01 M81969/14-01	M81969/8-02 M81969/14-01
20	850-006-20-615	M39029/106-615	20, 22, 24	M22520/1-01 M22520/2-01 M22520/7-01	M22520/1-04 (red) M22520/2-10 M22520/7-08	M81969/8-05 M81969/14-10	M81969/8-06 M81969/14-10
16	850-006-16-616	M39029/106-616	16, 18, 20	M22520/1-01 M22520/7-01	M22520/1-04 (blue) M22520/7-04	M81969/8-07 M81969/14-03	M81969/8-08 M81969/14-03
12	850-006-12-617	M39029/106-617	12, 14	M22520/1-01	M22520/1-04 (yellow)	M81969/8-09 M81969/14-04	M81969/8-10 M81969/14-03
10	850-006-10-618	M39029/106-618	10	Daniels 1716P-1	Daniels 1716P-1	M81969/14-05 and M81969/8-11	M81969/14-05 and M81969/8-12

D38999
 Ser. I, III, IV

M29600
Extended Duty Pin Crimp Contact for MIL-DTL-38999 Series I, III and IV Connectors
A

Mating End Size	Wire Accomodation	Military Part Number	Glenair Part Number
22	22-28 AWG	M39029/107-620	850-007-22-620
20	20-24 AWG	M39029/107-621	850-007-20-621
16	16-20 AWG	M39029/107-622	850-007-16-622
12	12-14 AWG	M39029/107-623	850-007-12-623
10	10 AWG	M39029/107-624	850-007-10-624

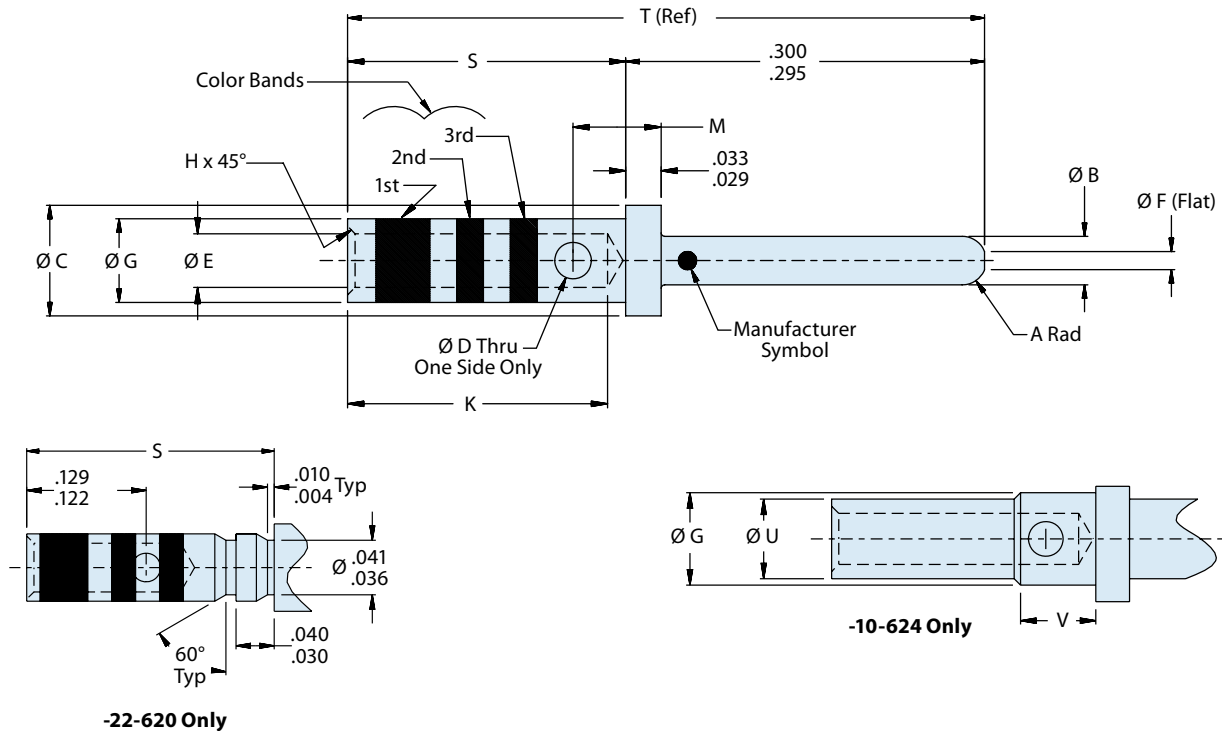
Material and Finish

Copper alloy, plated with 5 µinches gold over 45 µinches palladium alloy.
 Rated to 1500 cycles of durability.

M39029/107
850-007
Extended Duty Electrical Pin Contact



AS39029

A

TABLE I: CONTACT DIMENSIONS

Size	Part Number	Military Number	A Rad	ø B	ø C	ø D	ø E	ø F	ø G	H
22	850-007-22-620	M39029/107-620	.020 .010	.0305 .0295	.062 .060	.022 .018	.0355 .0335	.011 max	.048 .046	.005 .003
20	850-007-20-621	M39029/107-621	.025 .015	.041 .039	.094 .091	.032 .026	.048 .046	.015 max	.070 .068	.010 .005
16	850-007-16-622	M39029/107-622	.025 .020	.0635 .0616	.130 .127	.042 .036	.068 .066	.030 .011	.103 .101	.010 .005
12	850-007-12-623	M39029/107-623	.025 .020	.095 .093	.182 .179	.042 .036	.102 .098	.062 .043	.151 .148	.016 .005
10	850-007-10-624	M39029/107-624	.025 .020	.126 .124	.242 .238	.052 .040	.140 .134	.094 .074	.213 .207	.016 .005

TABLE I: (Continued) CONTACT DIMENSIONS

Size	Part Number	Military Number	K	M	S	T (Ref)	ø U	V	Color Bands		
									1st	2nd	3rd
22	850-007-22-620	M39029/107-620	.157 .141	-	.237 .231	.531	-	-	Blue	Red	Black
20	850-007-20-621	M39029/107-621	.229 .209	.078 .072	.237 .231	.531	-	-	Blue	Red	Brown
16	850-007-16-622	M39029/107-622	.229 .209	.088 .082	.237 .231	.531	-	-	Blue	Red	Red
12	850-007-12-623	M39029/107-623	.229 .209	.088 .082	.237 .231	.531	-	-	Blue	Red	Orange
10	850-007-10-624	M39029/107-624	.385 .355	.115 .108	.405 .395	.698	.183 .177	.121 .111	Blue	Red	Yellow

TABLE II: TOOL COMPATIBILITY

Size	Part Number	Military Number	AWG Handling	Crimp Tool	Positioner	Insertion Tool	Extraction Tool
22	850-007-22-620	M39029/107-620	22, 24, 26, 28	M22520/2-01 M22520/7-01	M22520/2-09 M22520/7-07	M81969/8-01 M81969/14-01	M81969/8-02 M81969/14-01
20	850-007-20-621	M39029/107-621	20, 22, 24	M22520/1-01 M22520/2-01 M22520/7-01	M22520/1-04 (red) M22520/2-10 M22520/7-08	M81969/8-05 M81969/14-10	M81969/8-06 M81969/14-10
16	850-007-16-622	M39029/107-622	16, 18, 20	M22520/1-01 M22520/7-01	M22520/1-04 (blue) M22520/7-04	M81969/8-07 M81969/14-03	M81969/8-08 M81969/14-03
12	850-007-12-623	M39029/107-623	12, 14	M22520/1-01	M22520/1-04 (yellow)	M81969/8-09 M81969/14-04	M81969/8-10 M81969/14-04
10	850-007-10-624	M39029/107-624	10	Daniels 1716P-1	Daniels 1716P-1	M81969/14-05 and M81969/8-11	M81969/14-05 and M81969/8-12

SERIES 257-606

QUADRAX

Glenair MIL-DTL-38999 Series III Type Quadrax Connectors



Glenair doesn't just make a complete range of high-frequency shielded contacts. We also make the connector packaging too—from Quadrax equipped circular connectors to Coax-equipped ARINC's, D-Subminiatures and our own Series 79 Micro-Crimp. As we like to say, we produce the complete solution—soup to nuts. And because we have decades of experience with all classes of high performance connectors, we're well positioned to design and manufacture a truly complete interconnect solution, including wire and cable, contacts, connectors, shielding, backshells, dust caps, shrink boots, you name it. Simply put, nobody else in the interconnect industry can offer such a comprehensive solution. Sure, we're happy to just be your contact supplier. But if you like our high-availability approach to that business (ample manufacturing capacity, same-day shipment inventory and the best and most available technical support team in the industry) we're thinking you'll love the service and support we bring to all our product lines. So give us a try. We promise you'll appreciate the extra value of working with a supplier that truly understands what availability is all about.



Shielded Contacts

High Performance: Coax, Twinax and Quadrax

From Coax...

Shielded coaxial contacts have a special role in the interconnect system and are designed for use in a wide range of military and aerospace connectors that service analog radio frequency or microwave applications. Most Glenair cylindrical connectors, including our D38999 type, can accommodate shielded contacts. Rectangular connector packages, such as our high-performance HiPer-D are also ideally suited for these shielded contacts.

...to Twinax and Quadrax

High-speed differential impedance contacts, such as those used in advanced digital communications applications, are another key specialty at Glenair. Our Twinax and Quadrax contacts are exactly engineered and manufactured using the best available materials and manufacturing processes. Conductive elements are gold-plated copper alloy. Dielectrics are high-performance fluorocarbon. When applicable, our shielded contacts are approved to SAE AS39029.

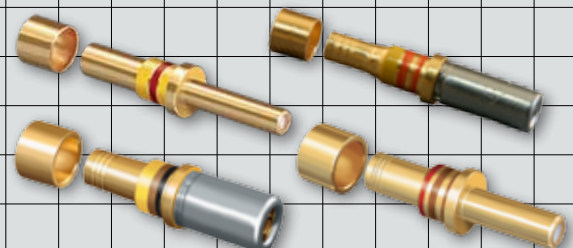

B

- ◆ Qualified to SAE-AS39029 on Dozens of Contacts—and Growing!
- ◆ Same Day Inventory on Popular and Hard-to-Find Styles
- ◆ Highest Quality Materials Including Enhanced Durability Plating
- ◆ Fully Intermatable with Equivalent AS39029 Contacts



High Performance Shielded Contacts Cross Reference

Military Part Number	Glenair Part Number	Contact Size	Pin / Socket	Type	BIN Color Striping			Product Page
					Red	Brown	Black	
M39029/27-210	852-001-12-210	12	Socket	Coaxial	Red	Brown	Black	B-4
M39029/27-402	852-001-12-402	12	Socket	Coaxial	Yellow	Black	Red	
M39029/27-403	852-001-12-403	12	Socket	Coaxial	Yellow	Black	Orange	
M39029/27-404	852-001-12-404	12	Socket	Coaxial	Yellow	Black	Yellow	
M39029/27-405	852-001-12-405	12	Socket	Coaxial	Yellow	Black	Green	
M39029/27-406	852-001-12-406	12	Socket	Coaxial	Yellow	Black	Blue	
M39029/27-407	852-001-12-407	12	Socket	Coaxial	Yellow	Black	Violet	
M39029/27-408	852-001-12-408	12	Socket	Coaxial	Yellow	Black	Gray	
M39029/28-211	852-002-12-211	12	Pin	Coaxial	Red	Brown	Brown	
M39029/28-409	852-002-12-409	12	Pin	Coaxial	Yellow	Black	White	
M39029/28-410	852-002-12-410	12	Pin	Coaxial	Yellow	Brown	Black	
M39029/28-411	852-002-12-411	12	Pin	Coaxial	Yellow	Brown	Brown	
M39029/28-412	852-002-12-412	12	Pin	Coaxial	Yellow	Brown	Red	
M39029/28-413	852-002-12-413	12	Pin	Coaxial	Yellow	Brown	Orange	
M39029/28-414	852-002-12-414	12	Pin	Coaxial	Yellow	Brown	Yellow	
M39029/28-415	852-002-12-415	12	Pin	Coaxial	Yellow	Brown	Green	
M39029/59-366	852-006-08-366	08	Socket	Coaxial	Orange	Blue	Blue	B-14
M39029/60-367	852-007-08-367	08	Pin	Coaxial	Orange	Blue	Violet	B-15
M39029/75-416	852-003-12-416	12	Socket	Coaxial	Yellow	Brown	Blue	B-8
M39029/75-417	852-003-12-417	12	Socket	Coaxial	Yellow	Brown	Violet	
M39029/75-418	852-003-12-418	12	Socket	Coaxial	Yellow	Brown	Gray	
M39029/75-419	852-003-12-419	12	Socket	Coaxial	Yellow	Brown	White	
M39029/75-420	852-003-12-420	12	Socket	Coaxial	Yellow	Red	Black	
M39029/75-421	852-003-12-421	12	Socket	Coaxial	Yellow	Red	Brown	
M39029/75-422	852-003-12-422	12	Socket	Coaxial	Yellow	Red	Red	
M39029/75-423	852-003-12-423	12	Socket	Coaxial	Yellow	Red	Orange	
M39029/76-424	852-008-16-424	16	Pin	Coaxial	Yellow	Red	Yellow	
M39029/76-425	852-008-16-425	16	Pin	Coaxial	Yellow	Red	Green	

High Performance Shielded Contacts Cross Reference



Military Part Number	Glenair Part Number	Contact Size	Pin / Socket	Type	BIN Color Striping			Product Page
					Color 1	Color 2	Color 3	
M39029/76-426	852-008-16-426	16	Pin	Coaxial	Yellow	Red	Blue	B-16
M39029/76-427	852-008-16-427	16	Pin	Coaxial	Yellow	Red	Violet	
M39029/77-428	852-009-16-428	16	Socket	Coaxial	Yellow	Red	Gray	B-18
M39029/77-429	852-009-16-429	16	Socket	Coaxial	Yellow	Red	White	
M39029/77-430	852-009-16-430	16	Socket	Coaxial	Yellow	Orange	Black	
M39029/77-431	852-009-16-431	16	Socket	Coaxial	Yellow	Orange	Brown	
M39029/78-432	852-010-16-432	16	Socket	Coaxial	Yellow	Orange	Red	B-20
M39029/78-433	852-010-16-433	16	Socket	Coaxial	Yellow	Orange	Orange	
M39029/78-434	852-010-16-434	16	Socket	Coaxial	Yellow	Orange	Yellow	
M39029/78-435	852-010-16-435	16	Socket	Coaxial	Yellow	Orange	Green	
M39029/90-529	853-001-08-529	8	Pin	Concentric Twinax	Green	Red	White	B-22
M39029/91-530	853-002-08-530	8	Socket	Concentric Twinax	Green	Orange	Black	B-23
M39029/102-558	852-004-12-558	12	Pin	Coaxial	Green	Green	Gray	B-10
M39029/103-559	852-005-12-559	12	Socket	Coaxial	Green	Green	White	B-12
M39029/113-625	853-003-08-625	8	Pin	Concentric Twinax	Blue	Red	Green	B-24
M39029/113-626	853-003-08-626	8	Pin	Concentric Twinax	Blue	Red	Blue	
M39029/114-628	853-004-08-628	8	Socket	Concentric Twinax	Blue	Red	Gray	B-25
M39029/114-629	853-004-08-629	8	Socket	Concentric Twinax	Blue	Red	White	
N/A	854-001-01	8	Pin	Quadrax	N/A			B-26
N/A	854-001-02	8	Pin	Quadrax	N/A			
N/A	854-001-03	8	Pin	Quadrax	N/A			
N/A	854-001-04	8	Pin	Quadrax	N/A			
N/A	854-001-05	8	Pin	Quadrax	N/A			
N/A	854-002-01	8	Socket	Quadrax	N/A			B-27
N/A	854-002-02	8	Socket	Quadrax	N/A			
N/A	854-002-03	8	Socket	Quadrax	N/A			
N/A	854-002-04	8	Socket	Quadrax	N/A			
N/A	854-002-05	8	Socket	Quadrax	N/A			

D38999
 Series II

Size #12 Coaxial Socket Contacts for MIL-DTL-38999 Series II Connectors

These #12 contacts accept 50 ohm and 75 ohm coaxial cable. Inner contact is rated at 1 amp, the outer contact 12 amps. DWV rating is 1000 Vac rms sea level, 250 Vac at 50,000 feet. Contacts are packaged individually and shipped unassembled with instruction sheet. One contact consists of outer contact, fluorocarbon dielectric, inner contact and shield crimp sleeve. Inner and outer contacts are gold-plated copper alloy. Approved to SAE AS39029. 5000 megohm insulation resistance.

B

Type	Cable Accommodation	Part Number	Military Part Number	Color Band		
				1st	2nd	3rd
Socket	RG174, RG316, RG179	852-001-12-210	M39029/27-210	Red	Brown	Black
	RG180	852-001-12-402	M39029/27-402	Yellow	Black	Red
	Microdot 250-4070	852-001-12-403	M39029/27-403	Yellow	Black	Orange
	Raychem 48-502, 5022E5111	852-001-12-404	M39029/27-404	Yellow	Black	Yellow
	Raychem 48-950, 9530D5117	852-001-12-405	M39029/27-405	Yellow	Black	Green
	Raychem 7624D1311, 9527A1318	852-001-12-406	M39029/27-406	Yellow	Black	Blue
	Gore GWN1159A	852-001-12-407	M39029/27-407	Yellow	Black	Violet
	1550MU-16, -20, -40, -70 (D24643/28)	852-001-12-408	M39029/27-408	Yellow	Black	Gray

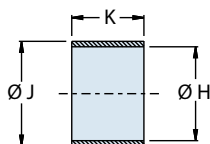
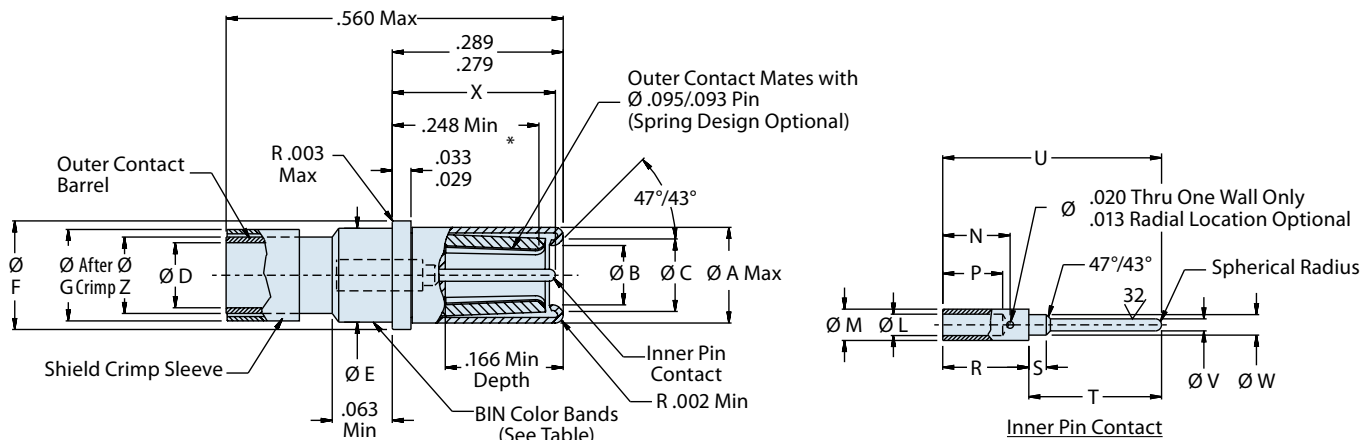

Shield Crimp Sleeve

Material and Finish

Contact Body: Copper Alloy/Gold Plated
 Hood: Stainless Steel/Passivated
 Center Contact: Copper Alloy/Gold Plated
 Crimp Sleeve: Copper Alloy/Gold Plated
 Insulator: Teflon

* Indicates point at which a square ended pin of the same basic diameter as the mating contact first engages the outer contact spring

M39029/27
852-001
Size 12 Coaxial Socket



Table I

BIN Code	ØA Max	ØB	ØC	ØD Max	ØE	ØF	ØG Max	ØH Min	ØJ Max	K	ØL Min
210	0.161 (4.1)	0.100 (2.54) 0.097 (2.46)	0.123 (3.1) 0.118 (3.0)	0.090 (2.3)	0.151 (3.84) 0.148 (3.76)	0.182 (4.6) 0.179 (4.5)	0.156 (4.0)	0.127 (3.2)	0.169 (4.3)	0.125 (3.2) 0.115(2.9)	0.225 (5.7)
402	0.161 (4.1)	0.100 (2.54) 0.097 (2.46)	0.123 (3.1) 0.118 (3.0)	0.108 (2.7)	0.151 (3.84) 0.148 (3.76)	0.182 (4.6) 0.179 (4.5)	0.156 (4.0)	0.144 (3.7)	0.169 (4.3)	0.125 (3.2) 0.115(2.9)	0.225 (5.7)
403	0.161 (4.1)	0.100 (2.54) 0.097 (2.46)	0.123 (3.1) 0.118 (3.0)	0.108 (2.7)	0.151 (3.84) 0.148 (3.76)	0.182 (4.6) 0.179 (4.5)	0.156 (4.0)	0.144 (3.7)	0.169 (4.3)	0.125 (3.2) 0.115(2.9)	0.355 (9.0)
404	0.161 (4.1)	0.100 (2.54) 0.097 (2.46)	0.123 (3.1) 0.118 (3.0)	0.090 (2.3)	0.151 (3.84) 0.148 (3.76)	0.182 (4.6) 0.179 (4.5)	0.156 (4.0)	0.127 (3.2)	0.169 (4.3)	0.125 (3.2) 0.115(2.9)	0.355 (9.0)
405	0.161 (4.1)	0.100 (2.54) 0.097 (2.46)	0.123 (3.1) 0.118 (3.0)	0.090 (2.3)	0.151 (3.84) 0.148 (3.76)	0.182 (4.6) 0.179 (4.5)	0.156 (4.0)	0.127 (3.2)	0.169 (4.3)	0.125 (3.2) 0.115(2.9)	0.225 (5.7)
406	0.161 (4.1)	0.100 (2.54) 0.097 (2.46)	0.123 (3.1) 0.118 (3.0)	0.117 (3.0)	0.151 (3.84) 0.148 (3.76)	0.182 (4.6) 0.179 (4.5)	0.156 (4.0)	0.156 (4.0)	0.174 (4.4)	0.125 (3.2) 0.115(2.9)	0.27 (6.9)
407	0.161 (4.1)	0.100 (2.54) 0.097 (2.46)	0.123 (3.1) 0.118 (3.0)	0.090 (2.3)	0.151 (3.84) 0.148 (3.76)	0.182 (4.6) 0.179 (4.5)	0.156 (4.0)	0.144 (3.7)	0.169 (4.3)	0.125 (3.2) 0.115(2.9)	0.225 (5.7)
408	0.161 (4.1)	0.100 (2.54)	0.123 (3.1) 0.118 (3.0)	0.108 (2.7)	0.151 (3.84) 0.148 (3.76)	0.182 (4.6) 0.179 (4.5)	0.156 (4.0)	0.156 (4.0)	0.174 (4.4)	0.125 (3.2) 0.115(2.9)	0.355 (9.0)

Table I (continued)

BIN Code	ØM Max	N Min	P	R	S	T	U Ref	ØV	ØW	X	ØZ Max
210	0.052 (1.3)	0.112 (2.8)	0.103 (2.6) 0.096 (2.4)	0.146 (3.7) 0.140 (3.6)	0.039 (1.0) 0.033 (0.8)	0.222 (5.64) 0.219 (5.56)	0.364 (9.2)	0.0205 (0.52) 0.0195 (0.5)	0.035(0.9) 0.033 (0.8)	0.276 (7.0) 0.266 (6.8)	0.110 (2.8)
402	0.052 (1.3)	0.112 (2.8)	0.103 (2.6) 0.096 (2.4)	0.146 (3.7) 0.140 (3.6)	0.039 (1.0) 0.033 (0.8)	0.222 (5.64) 0.219 (5.56)	0.364 (9.2)	0.0205 (0.52) 0.0195 (0.5)	0.035(0.9) 0.033 (0.8)	0.276 (7.0) 0.266 (6.8)	0.127 (3.2)
403	0.052 (1.3)	0.112 (2.8)	0.103 (2.6) 0.096 (2.4)	0.146 (3.7) 0.140 (3.6)	0.039 (1.0) 0.033 (0.8)	0.222 (5.64) 0.219 (5.56)	0.364 (9.2)	0.0205 (0.52) 0.0195 (0.5)	0.035(0.9) 0.033 (0.8)	0.276 (7.0) 0.266 (6.8)	0.127 (3.2)
404	0.052 (1.3)	0.112 (2.8)	0.103 (2.6) 0.096 (2.4)	0.146 (3.7) 0.140 (3.6)	0.039 (1.0) 0.033 (0.8)	0.222 (5.64) 0.219 (5.56)	0.364 (9.2)	0.0205 (0.52) 0.0195 (0.5)	0.035(0.9) 0.033 (0.8)	0.276 (7.0) 0.266 (6.8)	0.110 (2.8)
405	0.052 (1.3)	0.112 (2.8)	0.103 (2.6) 0.096 (2.4)	0.146 (3.7) 0.140 (3.6)	0.039 (1.0) 0.033 (0.8)	0.222 (5.64) 0.219 (5.56)	0.364 (9.2)	0.0205 (0.52) 0.0195 (0.5)	0.035(0.9) 0.033 (0.8)	0.276 (7.0) 0.266 (6.8)	0.110 (2.8)
406	0.052 (1.3)	0.112 (2.8)	0.103 (2.6) 0.096 (2.4)	0.146 (3.7) 0.140 (3.6)	0.039 (1.0) 0.033 (0.8)	0.222 (5.64) 0.219 (5.56)	0.364 (9.2)	0.0205 (0.52) 0.0195 (0.5)	0.035(0.9) 0.033 (0.8)	0.276 (7.0) 0.266 (6.8)	0.136
407	0.052 (1.3)	0.112 (2.8)	0.103 (2.6) 0.096 (2.4)	0.146 (3.7) 0.140 (3.6)	0.039 (1.0) 0.033 (0.8)	0.222 (5.64) 0.219 (5.56)	0.364 (9.2)	0.0205 (0.52) 0.0195 (0.5)	0.035(0.9) 0.033 (0.8)	0.276 (7.0) 0.266 (6.8)	0.110 (2.8)
408	0.052 (1.3)	0.112 (2.8)	0.103 (2.6) 0.096 (2.4)	0.146 (3.7) 0.140 (3.6)	0.039 (1.0) 0.033 (0.8)	0.222 (5.64) 0.219 (5.56)	0.364 (9.2)	0.0205 (0.52) 0.0195 (0.5)	0.035(0.9) 0.033 (0.8)	0.276 (7.0) 0.266 (6.8)	0.127 (3.2)

Table III

Inner Contact		Outer Contact		Insertion Tool	Extraction Tool
Basic Crimping Tool	Positioner	Basic Crimping Tool	Positioner		
M22520/2-01	M22520/2-34	M22520/31-01	M22520/31-02	M81969/8-09 or M81969/14-04	M81969/8-10 or M81969/14-04

D38999

Ser. I, II, III, IV

Size #12 Coaxial Pin Contacts for MIL-DTL-38999 Series I, II, III and IV Connectors



These #12 pin contacts accept 50 ohm and 75 ohm coaxial cable. Inner contact is rated at 1 amp, the outer contact 12 amps. DWV rating is 1000 Vac rms sea level, 250 Vac at 50,000 feet. Contacts are packaged individually and shipped unassembled with instruction sheet. One contact consists of outer contact, fluorocarbon dielectric, inner contact and shield crimp sleeve. Inner and outer contacts are gold-plated copper alloy. Approved to SAE AS39029. 5000 megohm insulation resistance. Mates with: M39029/75.

B

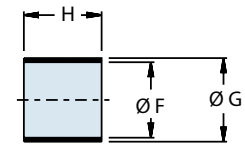
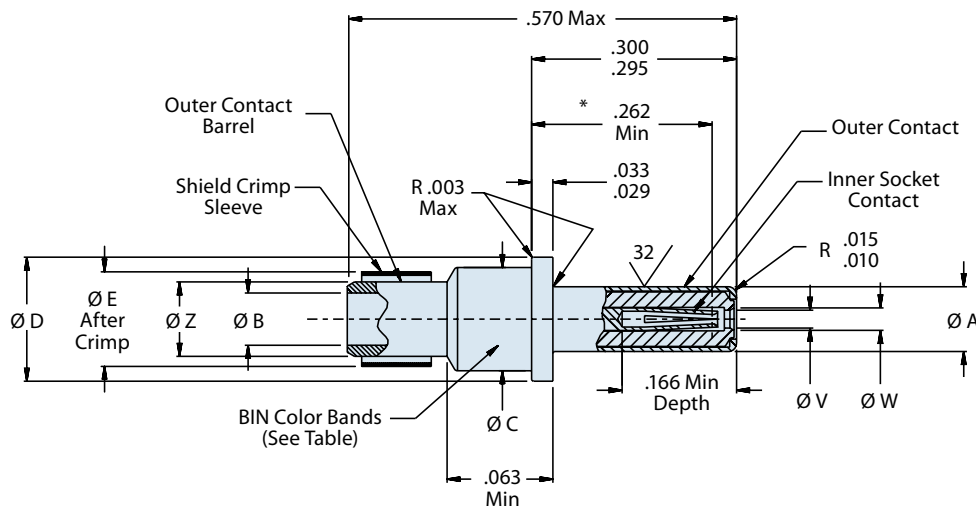
Type	Cable Accommodation	Part Number	Military Part Number	Color Band		
				1st	2nd	3rd
Pin	RG174, RG316, RG179	852-002-12-211	M39029/28-211	Red	Brown	Brown
	RG180	852-002-12-409	M39029/28-409	Yellow	Black	White
	Microdot 250-4070	852-002-12-410	M39029/28-410	Yellow	Brown	Black
	Raychem 48-502, 5022E5111	852-002-12-411	M39029/28-411	Yellow	Brown	Brown
	Raychem 48-950, 9530D5117	852-002-12-412	M39029/28-412	Yellow	Brown	Red
	Raychem 762D1311, 9527A1318	852-002-12-413	M39029/28-413	Yellow	Brown	Orange
	Gore GWN1159A, M17/152-00001	852-002-12-414	M39029/28-414	Yellow	Brown	Yellow
	1S50MU-16, -20, -40, -70 (D24643/28)	852-002-12-415	M39029/28-415	Yellow	Brown	Green

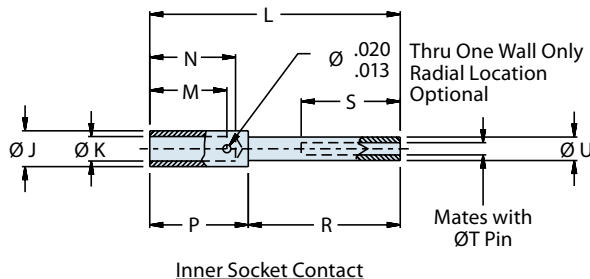

Shield Crimp Sleeve



Inner Socket Contact

Material and Finish

Contact Body: Copper Alloy/Gold Plated
 Center Contact: Copper Alloy/Gold Plated
 Crimp Sleeve: Copper Alloy/Gold Plated
 Insulator: Teflon

* Indicates point at which a square ended pin of the same basic diameter as the mating contact first engages the outer contact spring

M39029/28
852-002
Size 12 Coaxial Pin



Shielded
Contacts

B

Table I

BIN Code	ØA	ØB Min	ØC	ØD	ØE Max	ØF Min	ØG Max	H	ØJ Max	ØK Min	ØL Ref
211	0.095 (2.41) 0.093 (2.36)	.090 (2.3)	0.151 (3.84) 0.148 (3.76)	0.182 (4.62) 0.179 (4.55)	0.156 (4.0)	0.127 (3.2)	0.169 (4.3)	0.125 (3.2) 0.115 (2.9)	0.052 (1.3)	0.0225 (0.6)	0.363 (9.2)
409	0.095 (2.41) 0.093 (2.36)	.090 (2.3)	0.151 (3.84) 0.148 (3.76)	0.182 (4.62) 0.179 (4.55)	0.156 (4.0)	0.144 (3.7)	0.169 (4.3)	0.125 (3.2) 0.115 (2.9)	0.052 (1.3)	0.0225 (0.6)	0.363 (9.2)
410	0.095 (2.41) 0.093 (2.36)	.090 (2.3)	0.151 (3.84) 0.148 (3.76)	0.182 (4.62) 0.179 (4.55)	0.156 (4.0)	0.144 (3.7)	0.169 (4.3)	0.125 (3.2) 0.115 (2.9)	0.052 (1.3)	0.0355 (0.9)	0.363 (9.2)
411	0.095 (2.41) 0.093 (2.36)	.090 (2.3)	0.151 (3.84) 0.148 (3.76)	0.182 (4.62) 0.179 (4.55)	0.156 (4.0)	0.127 (3.2)	0.169 (4.3)	0.125 (3.2) 0.115 (2.9)	0.052 (1.3)	0.0355 (0.9)	0.363 (9.2)
412	0.095 (2.41) 0.093 (2.36)	.090 (2.3)	0.151 (3.84) 0.148 (3.76)	0.182 (4.62) 0.179 (4.55)	0.156 (4.0)	0.127 (3.2)	0.169 (4.3)	0.125 (3.2) 0.115 (2.9)	0.052 (1.3)	0.0225 (0.6)	0.363 (9.2)
413	0.095 (2.41) 0.093 (2.36)	.090 (2.3)	0.151 (3.84) 0.148 (3.76)	0.182 (4.62) 0.179 (4.55)	0.156 (4.0)	0.156 (4.0)	0.174 (4.4)	0.125 (3.2) 0.115 (2.9)	0.052 (1.3)	0.0270 (0.7)	0.363 (9.2)
414	0.095 (2.41) 0.093 (2.36)	.090 (2.3)	0.151 (3.84) 0.148 (3.76)	0.182 (4.62) 0.179 (4.55)	0.156 (4.0)	0.138 (3.5)	0.174 (4.4)	0.125 (3.2) 0.115 (2.9)	0.052 (1.3)	0.0225 (0.6)	0.363 (9.2)
415	0.095 (2.41) 0.093 (2.36)	.090 (2.3)	0.151 (3.84) 0.148 (3.76)	0.182 (4.62) 0.179 (4.55)	0.156 (4.0)	0.156 (4.0)	0.174 (4.4)	0.125 (3.2) 0.115 (2.9)	0.052 (1.3)	0.0355 (0.9)	0.363 (9.2)

Table I (continued)

BIN Code	M	N Min	P	R	S Min	T	U	ØV	ØW	ØZ Max
211	0.103 (2.6) 0.096 (2.4)	0.112 (2.8)	0.146 (3.7) 0.140 (3.6)	0.222 (5.64) 0.219 (5.56)	0.156 (4.0)	0.0205 (0.52) 0.0195 (0.50)	0.035 (0.9) 0.033 (0.8)	0.027 (0.7) 0.025 (0.6)	0.058 (1.5) 0.055 (1.4)	0.110 (2.8)
409	0.103 (2.6) 0.096 (2.4)	0.112 (2.8)	0.146 (3.7) 0.140 (3.6)	0.222 (5.64) 0.219 (5.56)	0.156 (4.0)	0.0205 (0.52) 0.0195 (0.50)	0.035 (0.9) 0.033 (0.8)	0.027 (0.7) 0.025 (0.6)	0.058 (1.5) 0.055 (1.4)	0.127 (3.2)
410	0.103 (2.6) 0.096 (2.4)	0.112 (2.8)	0.146 (3.7) 0.140 (3.6)	0.222 (5.64) 0.219 (5.56)	0.156 (4.0)	0.0205 (0.52) 0.0195 (0.50)	0.035 (0.9) 0.033 (0.8)	0.027 (0.7) 0.025 (0.6)	0.058 (1.5) 0.055 (1.4)	0.127 (3.2)
411	0.103 (2.6) 0.096 (2.4)	0.112 (2.8)	0.146 (3.7) 0.140 (3.6)	0.222 (5.64) 0.219 (5.56)	0.156 (4.0)	0.0205 (0.52) 0.0195 (0.50)	0.035 (0.9) 0.033 (0.8)	0.027 (0.7) 0.025 (0.6)	0.058 (1.5) 0.055 (1.4)	0.110 (2.8)
412	0.103 (2.6) 0.096 (2.4)	0.112 (2.8)	0.146 (3.7) 0.140 (3.6)	0.222 (5.64) 0.219 (5.56)	0.156 (4.0)	0.0205 (0.52) 0.0195 (0.50)	0.035 (0.9) 0.033 (0.8)	0.027 (0.7) 0.025 (0.6)	0.058 (1.5) 0.055 (1.4)	0.110 (2.8)
413	0.103 (2.6) 0.096 (2.4)	0.112 (2.8)	0.146 (3.7) 0.140 (3.6)	0.222 (5.64) 0.219 (5.56)	0.156 (4.0)	0.0205 (0.52) 0.0195 (0.50)	0.035 (0.9) 0.033 (0.8)	0.027 (0.7) 0.025 (0.6)	0.058 (1.5) 0.055 (1.4)	0.136 (3.5)
414	0.103 (2.6) 0.096 (2.4)	0.112 (2.8)	0.146 (3.7) 0.140 (3.6)	0.222 (5.64) 0.219 (5.56)	0.156 (4.0)	0.0205 (0.52) 0.0195 (0.50)	0.035 (0.9) 0.033 (0.8)	0.027 (0.7) 0.025 (0.6)	0.058 (1.5) 0.055 (1.4)	0.110 (2.8)
415	0.103 (2.6) 0.096 (2.4)	0.112 (2.8)	0.146 (3.7) 0.140 (3.6)	0.222 (5.64) 0.219 (5.56)	0.156 (4.0)	0.0205 (0.52) 0.0195 (0.50)	0.035 (0.9) 0.033 (0.8)	0.027 (0.7) 0.025 (0.6)	0.058 (1.5) 0.055 (1.4)	0.127 (3.2)

Table III

Inner Contact		Outer Contact		Insertion Tool	Extraction Tool
Basic Crimping Tool	Positioner	Basic Crimping Tool	Positioner		
M22520/2-01	M22520/2-34	M22520/31-01	M22520/31-02	M81969/8-09 or M81969/14-04	M81969/8-10 or M81969/14-04

D38999
 Ser. I, III, IV

Size #12 Coaxial Socket Contacts for MIL-DTL-38999 Series I, III and IV Connectors

These #12 socket contacts accept 50 ohm and 75 ohm coaxial cable. Inner contact is rated at 1 amp, the outer contact 12 amps. DWV rating is 1000 Vac rms sea level, 250 Vac at 50,000 feet. Contacts are packaged individually and shipped unassembled with instruction sheet. One contact consists of outer contact, fluorocarbon dielectric, inner contact and shield crimp sleeve. Inner and outer contacts are gold-plated copper alloy. Approved to SAE AS39029. 5000 megohm insulation resistance. Mates with: M39029/28.

Type	Cable Accommodation	Part Number	Military Part Number	Color Band		
				1st	2nd	3rd
Socket	M17/119-RG174, M17/113-RG316, M17/094-RG179, Times AA3248, Teledyne 11299, Haveg 8100207, Thermax 75-738-BCCWXE, Tensolite 3088/L707YX-1	852-003-12-416	M39029/75-416	Yellow	Brown	Blue
	M17/095-RG, Raychem 9527D1514-2L, Raychem 9528A1318, Microdot 293-3922	852-003-12-417	M39029/75-417	Yellow	Brown	Violet
	Microdot 250-4070	852-003-12-418	M39029/75-418	Yellow	Brown	Gray
	Raychem 48-502, 5022E5111	852-003-12-419	M39029/75-419	Yellow	Brown	White
	Raychem 48-950, 9530D5117	852-003-12-420	M39029/75-420	Yellow	Red	Black
	Raychem 7624D1311, 9527A1318	852-003-12-421	M39029/75-421	Yellow	Red	Brown
	Gore GWN1159A, M17/152-00001	852-003-12-422	M39029/75-422	Yellow	Red	Red
	1550MU-16, -20, -40, -70 (D24643/28)	852-003-12-423	M39029/75-423	Yellow	Red	Orange

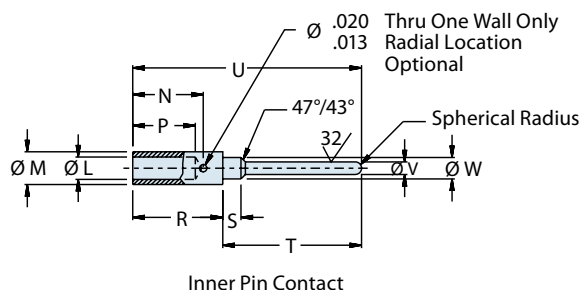
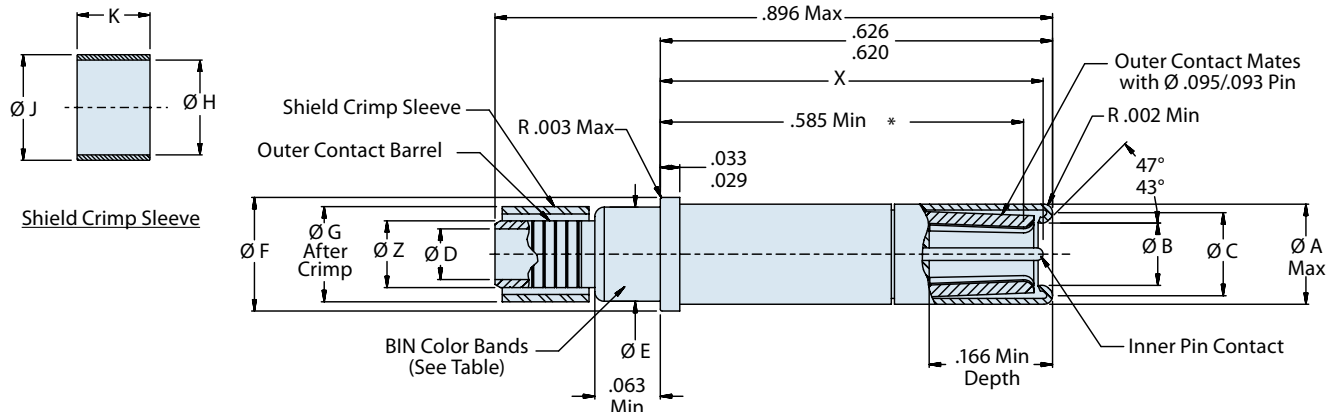
Material and Finish

Contact Body: Copper Alloy/Gold Plated
 Hood: Stainless Steel/Passivated
 Center Contact: Copper Alloy/Gold Plated
 Crimp Sleeve: Copper Alloy/Gold Plated
 Insulator: Teflon

* Indicates point at which a square ended pin of the same basic diameter as the mating contact first engages the outer contact spring

M39029/75
852-003
Size 12 Coaxial Socket



Table I

BIN Code	ØA Max	ØB	ØC	ØD Max	ØE	ØF	ØG Max	ØH Min	ØJ Max	K	ØL Min
416	0.161 (4.1)	.100 (2.54) .097 (2.46)	.123 (3.1) .118 (3.0)	.090 (2.3)	.151 (3.84) .148 (3.76)	.182 (4.6) .179 (4.5)	.156 (4.0)	.127 (3.2)	.169 (4.3)	.125 (3.2) .115 (2.9)	.0225 (.57)
417	0.161 (4.1)	.100 (2.54) .097 (2.46)	.123 (3.1) .118 (3.0)	.108 (2.7)	.151 (3.84) .148 (3.76)	.182 (4.6) .179 (4.5)	.156 (4.0)	.144 (3.7)	.169 (4.3)	.125 (3.2) .115 (2.9)	.0225 (.57)
418	0.161 (4.1)	.100 (2.54) .097 (2.46)	.123 (3.1) .118 (3.0)	.108 (2.7)	.151 (3.84) .148 (3.76)	.182 (4.6) .179 (4.5)	.156 (4.0)	.144 (3.7)	.169 (4.3)	.125 (3.2) .115 (2.9)	.0355 (.90)
419	0.161 (4.1)	.100 (2.54) .097 (2.46)	.123 (3.1) .118 (3.0)	.090 (2.3)	.151 (3.84) .148 (3.76)	.182 (4.6) .179 (4.5)	.156 (4.0)	.127 (3.2)	.169 (4.3)	.125 (3.2) .115 (2.9)	.0355 (.90)
420	0.161 (4.1)	.100 (2.54) .097 (2.46)	.123 (3.1) .118 (3.0)	.090 (2.3)	.151 (3.84) .148 (3.76)	.182 (4.6) .179 (4.5)	.156 (4.0)	.127 (3.2)	.169 (4.3)	.125 (3.2) .115 (2.9)	.0225 (.57)
421	0.161 (4.1)	.100 (2.54) .097 (2.46)	.123 (3.1) .118 (3.0)	0.117 (3.0)	.151 (3.84) .148 (3.76)	.182 (4.6) .179 (4.5)	.156 (4.0)	.156 (4.0)	0.174 (4.4)	.125 (3.2) .115 (2.9)	.0270 (.70)
422	0.161 (4.1)	.100 (2.54) .097 (2.46)	.123 (3.1) .118 (3.0)	.090 (2.3)	.151 (3.84) .148 (3.76)	.182 (4.6) .179 (4.5)	.156 (4.0)	.138 (3.5)	0.174 (4.4)	.125 (3.2) .115 (2.9)	.0225 (.57)
423	0.161 (4.1)	.100 (2.54) .097 (2.46)	.123 (3.1) .118 (3.0)	.108 (2.7)	.151 (3.84) .148 (3.76)	.182 (4.6) .179 (4.5)	.156 (4.0)	.156 (4.0)	0.174 (4.4)	.125 (3.2) .115 (2.9)	.0355 (.90)

Table I (Continued)

BIN Code	ØM Max	N Min	P	R	S	T	U Ref	ØV	ØW	X	ØZ Max
416	.052 (1.3)	.112 (2.8)	.103 (2.6) .096 (2.4)	.146 (3.7) .140 (3.6)	.039 (1.0) .033 (0.8)	.222 (5.64) .219 (5.56)	.3635 (9.2)	.0205 (.52) .0195 (.50)	.035 (0.9) .033 (0.8)	.613 (15.6) .603 (15.3)	.110 (2.8)
417	.052 (1.3)	.112 (2.8)	.103 (2.6) .096 (2.4)	.146 (3.7) .140 (3.6)	.039 (1.0) .033 (0.8)	.222 (5.64) .219 (5.56)	.3635 (9.2)	.0205 (.52) .0195 (.50)	.035 (0.9) .033 (0.8)	.613 (15.6) .603 (15.3)	.127 (3.2)
418	.052 (1.3)	.112 (2.8)	.103 (2.6) .096 (2.4)	.146 (3.7) .140 (3.6)	.039 (1.0) .033 (0.8)	.222 (5.64) .219 (5.56)	.3635 (9.2)	.0205 (.52) .0195 (.50)	.035 (0.9) .033 (0.8)	.613 (15.6) .603 (15.3)	.127 (3.2)
419	.052 (1.3)	.112 (2.8)	.103 (2.6) .096 (2.4)	.146 (3.7) .140 (3.6)	.039 (1.0) .033 (0.8)	.222 (5.64) .219 (5.56)	.3635 (9.2)	.0205 (.52) .0195 (.50)	.035 (0.9) .033 (0.8)	.613 (15.6) .603 (15.3)	.110 (2.8)
420	.052 (1.3)	.112 (2.8)	.103 (2.6) .096 (2.4)	.146 (3.7) .140 (3.6)	.039 (1.0) .033 (0.8)	.222 (5.64) .219 (5.56)	.3635 (9.2)	.0205 (.52) .0195 (.50)	.035 (0.9) .033 (0.8)	.613 (15.6) .603 (15.3)	.110 (2.8)
421	.052 (1.3)	.112 (2.8)	.103 (2.6) .096 (2.4)	.146 (3.7) .140 (3.6)	.039 (1.0) .033 (0.8)	.222 (5.64) .219 (5.56)	.3635 (9.2)	.0205 (.52) .0195 (.50)	.035 (0.9) .033 (0.8)	.613 (15.6) .603 (15.3)	.136 (3.5)
422	.052 (1.3)	.112 (2.8)	.103 (2.6) .096 (2.4)	.146 (3.7) .140 (3.6)	.039 (1.0) .033 (0.8)	.222 (5.64) .219 (5.56)	.3635 (9.2)	.0205 (.52) .0195 (.50)	.035 (0.9) .033 (0.8)	.613 (15.6) .603 (15.3)	.110 (2.8)
423	.052 (1.3)	0.355 (9.0)	.103 (2.6) .096 (2.4)	.146 (3.7) .140 (3.6)	.039 (1.0) .033 (0.8)	.222 (5.64) .219 (5.56)	.3635 (9.2)	.0205 (.52) .0195 (.50)	.035 (0.9) .033 (0.8)	.613 (15.6) .603 (15.3)	.127 (3.2)

Table III

Inner Contact		Outer Contact		Insertion Tool	Extraction Tool
Basic Crimping Tool	Positioner	Basic Crimping Tool	Positioner		
M22520/2-01	M22520/2-34	M22520/31-01	M22520/31-02	M81969/8-09 or M81969/14-04; DAK95-12B or DAK264-12	M81969/8-10 or M81969/14-04; DRK95-12B or DRK264-12

D38999

Ser. I, II, III, IV

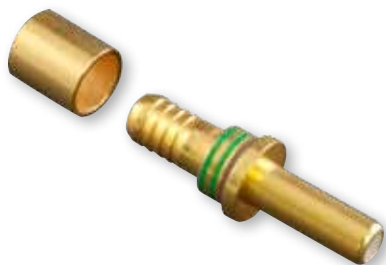
Size #12 Coaxial Pin Contacts for MIL-DTL-38999 Series I, II, III and IV Connectors

These contacts offer improved frequency response compared to standard coaxial contacts. VSWR is 1.32:1 at 3GHz. Nominal impedance is 50 ohms. Insertion loss at 3GHz is 0.20 dB maximum. Inner contact is rated at 1 amp, the outer contact 12 amps. DWV voltage rating is 1000 Vac rms sea level, 250 Vac at 50,000 feet. Contacts are packaged individually and shipped unassembled with instruction sheet. Inner and outer contacts are gold-plated copper alloy. 5000 megohm insulation resistance.

B

Type	Cable Accommodation	Part Number	Military Part Number	Color Band		
				1st	2nd	3rd
Pin	M17/113-RG316	852-004-12-558	M39029/102-558	Green	Green	Gray
	M17/094-RG179					

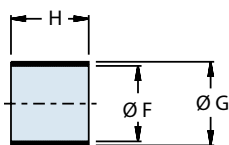
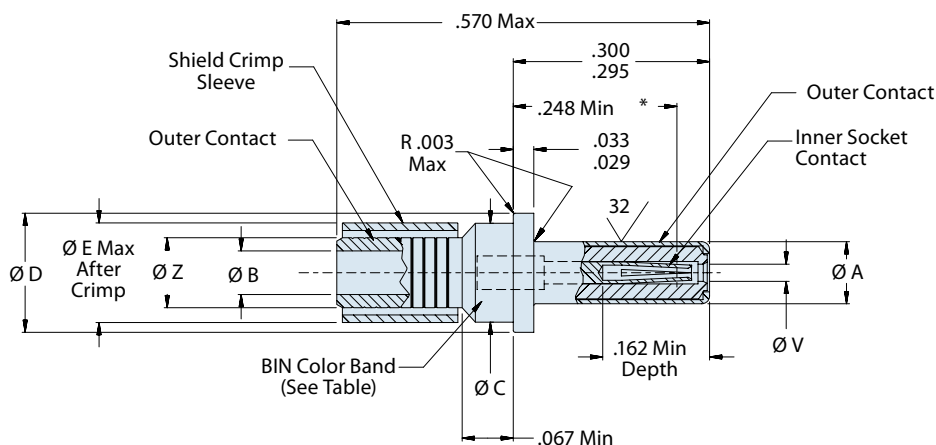

Shield Crimp Sleeve

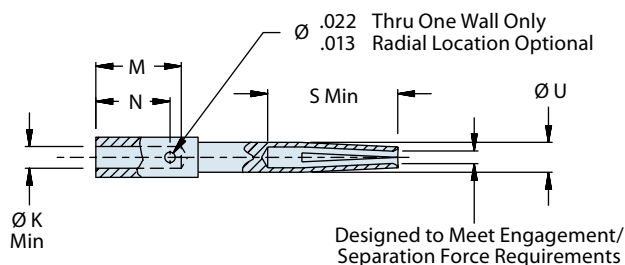

Inner Socket Contact

M39029/102
852-004
Size 12 Coaxial Pin



Table I

BIN Code	ØA	ØB Min	ØC	ØD	ØE Max	ØF Min	ØG Max
558	.095 (2.41) .093 (2.39)	.066 (1.7)	.151 (3.84) .148 (3.76)	.182 (4.62) .179 (4.55)	.156 (4.0)	.127 (3.2)	.169 (4.3)

Table I (continued)

BIN Code	H	ØK Min	M	N	S Min	U	ØV	ØZ Max
558	.180 (4.6) .170 (4.3)	.022 (.6)	.088 (2.2) .063 (1.6)	.100 (2.5) .084 (2.1)	.135 (3.4)	.035 (.9) .031 (.8)	.027 (.7) .025 (.6)	.110 (2.8)

Table III

Inner Contact		Outer Contact		Insertion Tool	Extraction Tool
Basic Crimping Tool	Positioner	Basic Crimping Tool	Die		
Daniels MH992	Glenair 859-006 or K1721	M22520/5-01	M22520/5-03	M81969/8-09 or M81969/14-04	M81969/8-10 or M81969/14-04

Material and Finish

Contact Body: Copper Alloy/Gold Plated
Hood: Stainless Steel/Passivated
Center Contact: Copper Alloy/Gold Plated
Crimp Sleeve: Copper Alloy/Gold Plated
Insulator: Teflon

* Indicates point at which a square ended pin of the same basic diameter as the mating contact first engages the outer contact spring

D38999
 Ser. I, III, IV

Size #12 Coaxial Socket Contacts for MIL-DTL-38999 Series I, III and IV Connectors



These contacts offer improved frequency response compared to standard coaxial contacts. VSWR is 1.32:1 at 3GHz. Nominal impedance is 50 ohms. Insertion loss at 3GHz is 0.20 dB maximum. Inner contact is rated at 1 amp, the outer contact 12 amps. DWV voltage rating is 1000 Vac rms sea level, 250 Vac at 50,000 feet. Contacts are packaged individually and shipped unassembled with instruction sheet. Inner and outer contacts are gold-plated copper alloy. 5000 megohm insulation resistance.

B

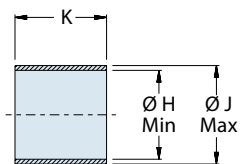
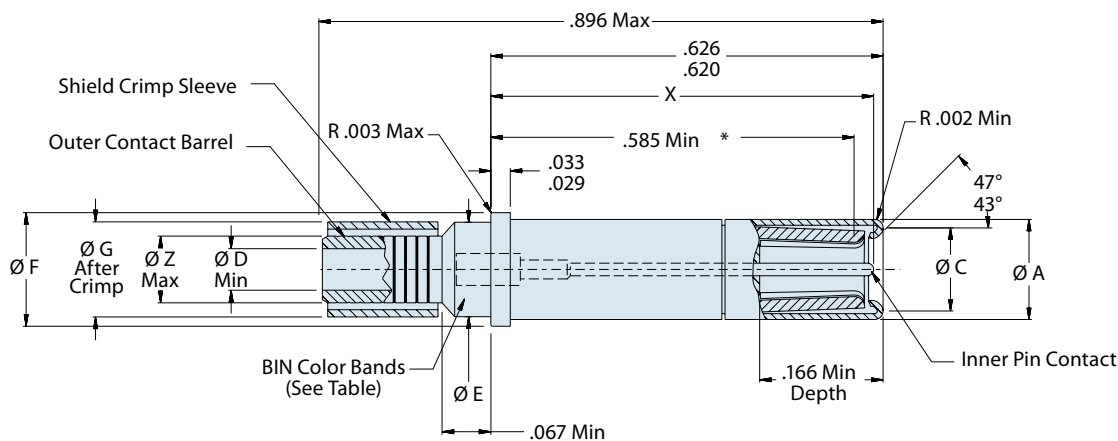
Type	Cable Accommodation	Part Number	Military Part Number	Color Band		
				1st	2nd	3rd
Socket	M17/113-RG316	852-005-12-559	M39029/103-559	Green	Green	White
	M17/094-RG179					

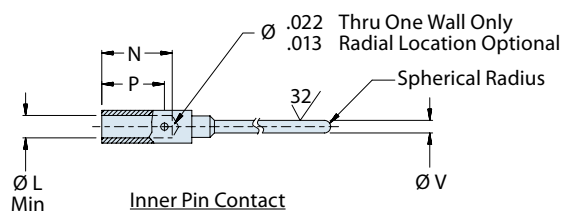

Shield Crimp Sleeve



Inner Pin Contact

M39029/103
852-005
Size 12 Coaxial Socket



Table I

BIN Code	ØA	ØC	ØD	ØE	ØF	ØG Max	ØH Max	ØJ Max
559	.160 (4.06) .158 (4.01)	.123 (3.1) .118 (3.0)	.069 (1.8) .066 (1.7)	.151 (3.84) .148 (3.76)	.182 (4.62) .179 (4.55)	.156 (4.0)	.127 (3.2)	.169 (4.3)

Table I (continued)

BIN Code	K	ØL Min	N	P	ØV	X	ØZ Max
559	.180 (4.6) .170 (4.3)	.022 (.6)	.100 (2.5) .084 (2.1)	.088 (2.2) .063 (1.6)	.0205 (.52) .0195 (.50)	.613 (15.6) .603 (15.3)	.110 (2.8)

Table III

Inner Contact		Outer Contact		Insertion Tool	Extraction Tool
Basic Crimping Tool	Positioner	Basic Crimping Tool	Die		
Daniels MH992	M22520/2-34	M22520/5-01	M22520/5-03	M81969/8-09 or M81969/14-04	M81969/8-10 or M81969/14-04

Note: May be crimped or soldered

Material and Finish

Contact Body: Copper Alloy/Gold Plated
Hood: Stainless Steel/Passivated
Center Contact: Copper Alloy/Gold Plated
Crimp Sleeve: Copper Alloy/Gold Plated
Insulator: Teflon

* Indicates point at which a square ended pin of the same basic diameter as the mating contact first engages the outer contact spring



M39029/59
852-006
Size 8 Coaxial Socket

D38999
Ser. I, III, IV

Size #8 Coaxial Socket Contacts for MIL-DTL-38999 Series I, III and IV Connectors



These #8 socket contacts accept 95 ohm coaxial cable. Inner contact is rated at 1 amp, the outer contact 12 amps. DWV rating is 1,300 Vac rms sea level, 250 Vac at 50,000 feet. Contacts are packaged individually and shipped unassembled with instruction sheet. One contact consists of outer contact, fluorocarbon dielectric, inner contact and shield crimp sleeve. Inner and outer contacts are gold-plated copper alloy. Approved to SAE AS39029. 5000 megohm insulation resistance. Mates with: M39029/60.

B

Type	Cable Accommodation	Part Number	Military Part Number	Color Band		
				1st	2nd	3rd
Socket	M17/095-RG180	852-006-08-366	M39029/59-366	Orange	Blue	Blue

Insertion Tool	Extraction Tool	Insulator Expander Tool (crimp only)
None Required - Hand Installed	MIL-I-81969/14-06	11-10134

Center Contact Tooling		Shield Crimp Sleeve Tooling	
Basic Crimping Tool	Contact Positioner	Basic Crimping Tool	Die Part or Identifying No.
M22520/2-01	M22520/2-31	M22520/5-01 M22520/10-1	M22520/5-05 Die Closure B M22520/10-07 Die Closure B

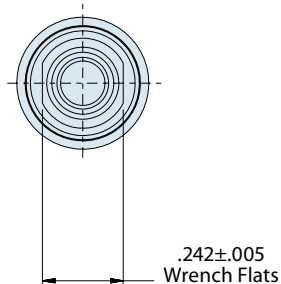
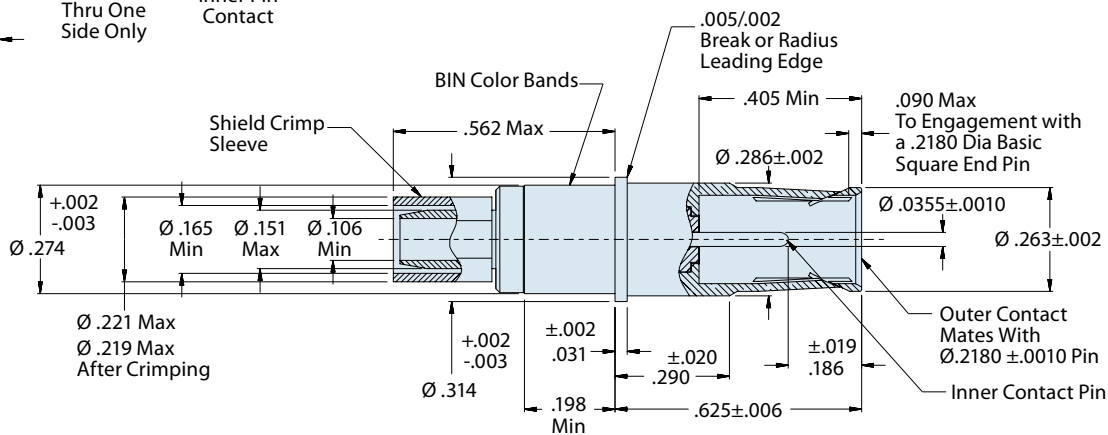
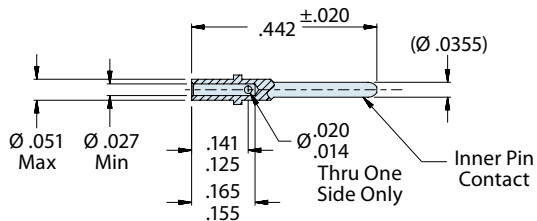

Material and Finish

Contact Body: Copper Alloy/Gold Plated
Center Contact: Copper Alloy/Gold Plated
Ferrule: Copper Alloy/Gold Plated
Insulator: Teflon

M39029/60
852-007
Size 8 Coaxial Pin



D38999
 Ser. I, III, IV

Size #8 Coaxial Pin Contacts for MIL-DTL-38999 Series I, III and IV Connectors



These #8 pin contacts accept 95 ohm coaxial cable. Inner contact is rated at 1 amp, the outer contact 12 amps. DWV rating is 1,300 Vac rms sea level, 250 Vac at 50,000 feet. Contacts are packaged individually and shipped unassembled with instruction sheet. One contact consists of outer contact, fluorocarbon dielectric, inner contact and shield crimp sleeve. Inner and outer contacts are gold-plated copper alloy. Approved to SAE AS39029. 5000 megohm insulation resistance. Mates with: M39029/60.

Type	Cable Accommodation	Part Number	Military Part Number	Color Band		
				1st	2nd	3rd
Socket	M17/095-RG180	852-007-08-367	M39029/60-367	Orange	Blue	Violet

B

Insertion Tool	Extraction Tool	Insulator Expander Tool (crimp only)
None Required - Hand Installed	MIL-I-81969/14-06	11-10134

Center Contact Tooling		Shield Crimp Sleeve Tooling	
Basic Crimping Tool	Contact Positioner	Basic Crimping Tool	Die Part or Identifying No.
M22520/2-01	M22520/2-31	M22520/5-01 M22520/10-1	M22520/5-05 Die Closure B M22520/10-07 Die Closure B

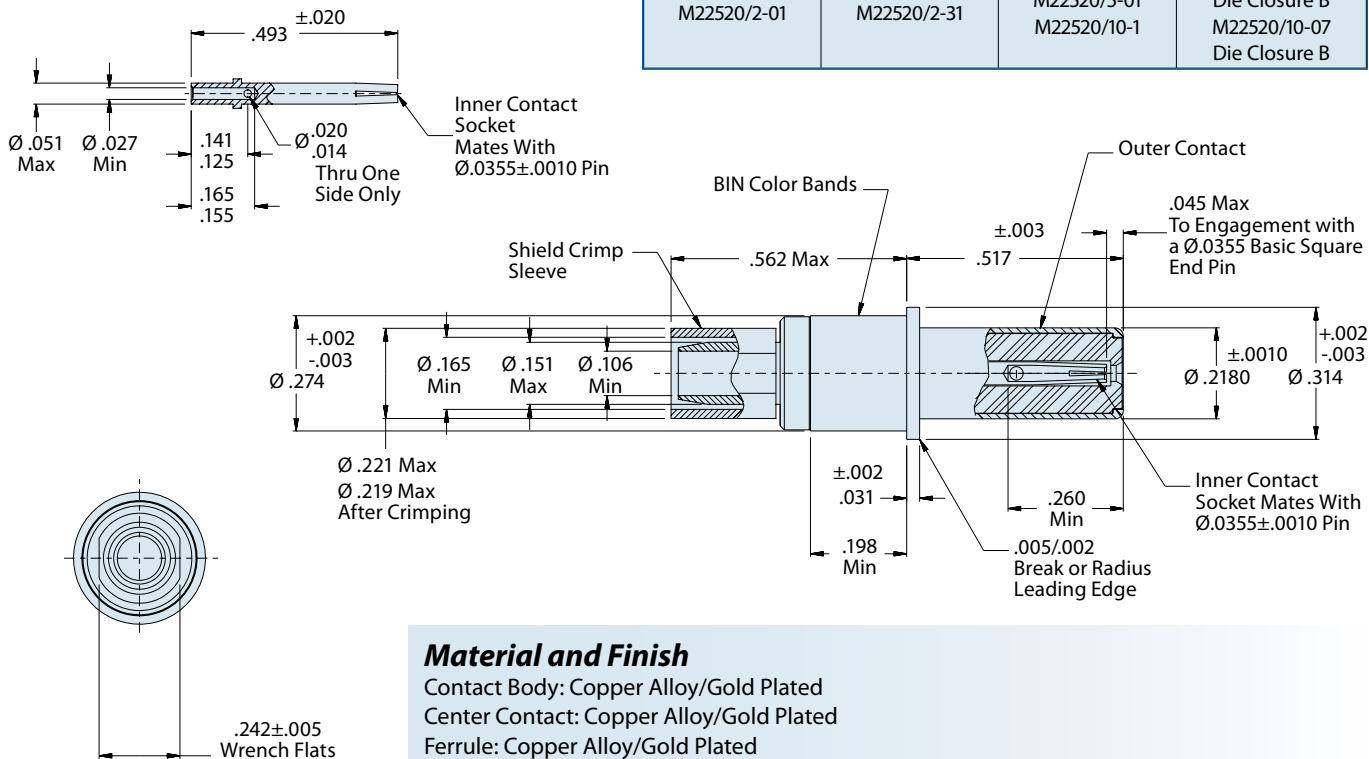

Material and Finish

Contact Body: Copper Alloy/Gold Plated
 Center Contact: Copper Alloy/Gold Plated
 Ferrule: Copper Alloy/Gold Plated
 Insulator: Teflon

D38999

Ser. I, II, III, IV

Size #16 Coaxial Pin Contacts for MIL-DTL-38999 Series I, II, III and IV Connectors

These #16 pin contacts accept 50 ohm and 75 ohm coaxial cable. Inner contact is rated at 1 amp, the outer contact 12 amps. DWV rating is 800 Vac rms sea level, 250 Vac at 50,000 feet. Contacts are packaged individually and are unassembled with instruction sheet. One contact consists of outer contact, fluorocarbon dielectric, inner contact and shield crimp sleeve. Inner and outer contacts are gold-plated copper alloy. Approved to SAE AS39029. VSWR rating 1.5:1 maximum up to 700 MHz. 5000 megohm insulation resistance. Mates with: M39029/77 and /78.

B

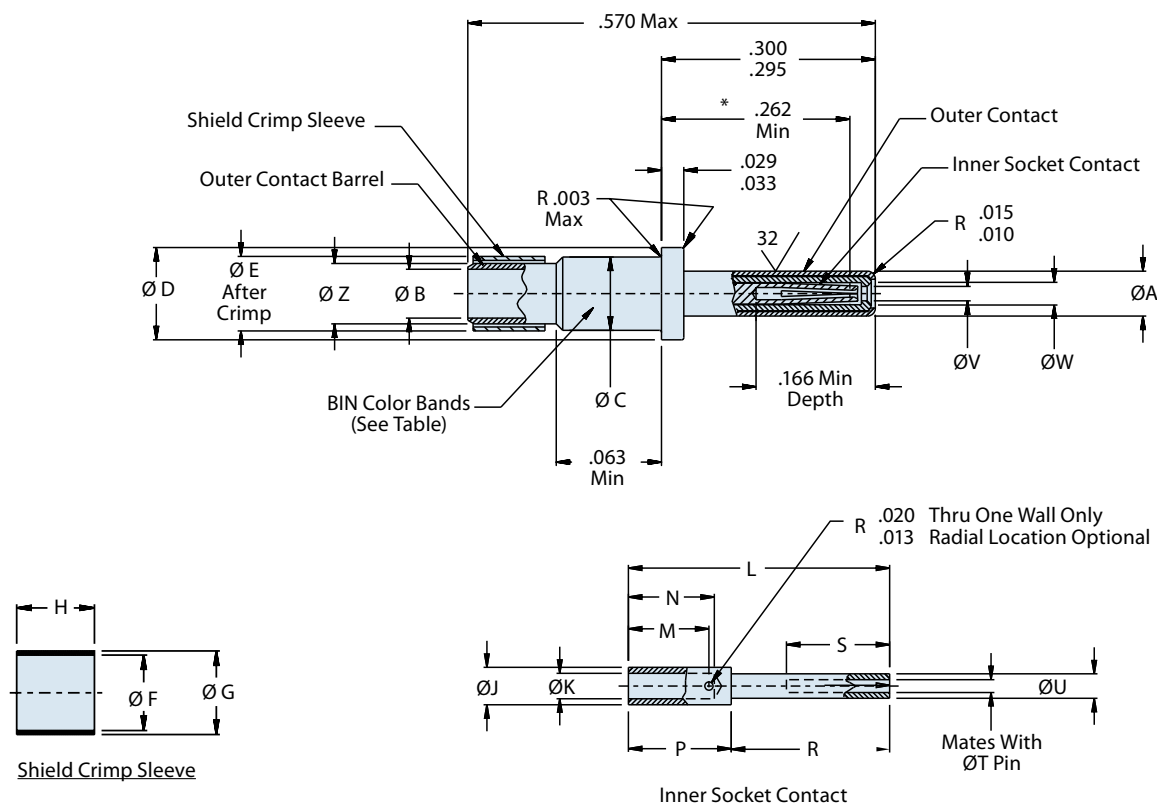
Material and Finish

Contact Body: Copper Alloy/Gold Plated
 Center Contact: Copper Alloy/Gold Plated
 Crimp Sleeve: Copper Alloy/Gold Plated
 Insulator: Teflon

* Indicates point at which a square ended pin of the same basic diameter as the mating contact first engages the outer contact spring

M39029/76
852-008
Size 16 Coaxial Pin



Type	Cable Accommodation	Part Number	Military Part Number	Color Band		
				1st	2nd	3rd
Pin	M17/119-RG174, M17/113-RG316, M17/094-RG179, Times AA3248, Teledyne 11299, Haveg 8100207, Thermax 75-738-BCCWXE, Tensolite 3088/L707YX-1	852-008-16-424	M39029/76-424	Yellow	Red	Yellow
	M19/093-RG178	852-008-16-425	M39029/76-425	Yellow	Red	Green
	Haveg 61-02051, Revere WH95623	852-008-16-426	M39029/76-426	Yellow	Red	Blue
	Haveg 30-00761, Haveg 30-02024, Haveg 30-02033, Tensolite 24713/A955KK1, Tensolite 26723/A955KK1	852-008-16-427	M39029/76-427	Yellow	Red	Violet

Table I											
BIN Code	ØA	ØB Min	ØC	ØD	ØE Max	ØF Min	ØG Max	H	ØJ Max	ØK Min	ØL Ref
424	.0635 (1.61) .0615 (1.56)	.0670 (1.7018)	.103 (2.62) .101 (2.57)	.130 (3.3) .127 (3.2)	0.108 (2.7)	0.105 (2.7)	0.120 (3.0)	.105 (2.7) .095 (2.4)	0.046 (1.2)	.0210 (0.5)	.392 (10.0)
425	.0635 (1.61) .0615 (1.56)	.0575 (1.4605)	.103 (2.62) .101 (2.57)	.130 (3.3) .127 (3.2)	0.108 (2.7)	0.094 (2.4)	0.120 (3.0)	.105 (2.7) .095 (2.4)	0.046 (1.2)	.0210 (0.5)	.392 (10.0)
426	.0635 (1.61) .0615 (1.56)	.0670 (1.7018)	.103 (2.62) .101 (2.57)	.130 (3.3) .127 (3.2)	0.108 (2.7)	0.105 (2.7)	0.120 (3.0)	.105 (2.7) .095 (2.4)	0.052 (1.3)	.0355 (0.9)	.392 (10.0)
427	.0635 (1.61) .0615 (1.56)	.0575 (1.4605)	.103 (2.62) .101 (2.57)	.130 (3.3) .127 (3.2)	0.108 (2.7)	0.094 (2.4)	0.120 (3.0)	.105 (2.7) .095 (2.4)	0.046 (1.2)	.0270 (0.7)	.392 (10.0)

Table I (continued)										
BIN Code	M	N Min	P	R	S Min	T	U	ØV	ØW	ØZ Max
424	.094 (2.4) .087 (2.2)	0.103 (2.6)	.125 (3.2) .119 (3.0)	.271 (6.9) .269 (6.8)	0.156 (4.0)	.0155 (.39) .0145 (.37)	.030 (.8) .028 (.7)	.022 (.6) .018 (.5)	.041 (1.04) .038 (.097)	0.085 2.2
425	.094 (2.4) .087 (2.2)	0.103 (2.6)	.125 (3.2) .119 (3.0)	.271 (6.9) .269 (6.8)	0.156 (4.0)	.0155 (.39) .0145 (.37)	.030 (.8) .028 (.7)	.022 (.6) .018 (.5)	.041 (1.04) .038 (.097)	0.076 1.9
426	.094 (2.4) .087 (2.2)	0.103 (2.6)	.125 (3.2) .119 (3.0)	.271 (6.9) .269 (6.8)	0.156 (4.0)	.0155 (.39) .0145 (.37)	.030 (.8) .028 (.7)	.022 (.6) .018 (.5)	.041 (1.04) .038 (.097)	0.085 2.2
427	.094 (2.4) .087 (2.2)	0.103 (2.6)	.125 (3.2) .119 (3.0)	.271 (6.9) .269 (6.8)	0.156 (4.0)	.0155 (.39) .0145 (.37)	.030 (.8) .028 (.7)	.022 (.6) .018 (.5)	.041 (1.04) .038 (.097)	0.076 1.9

Table III					
Inner Contact		Outer Contact		Insertion Tool	Extraction Tool
Basic Crimping Tool	Positioner	Basic Crimping Tool	Positioner		
M22520/2-01	M22520/2-35	M22520/4-01	M22520/4-02	M81969/8-07 or M81969/14-03	M81969/8-08 or M81969/14-03

D38999
 Ser. I, III, IV

Size #16 Coaxial Socket Contacts for MIL-DTL-38999 Series I, III and IV Connectors

These #16 socket contacts accept 50 ohm and 75 ohm coaxial cable. Inner contact is rated at 1 amp, the outer contact 12 amps. DWV rating is 800 Vac rms sea level, 250 Vac at 50,000 feet. Contacts are packaged individually and are unassembled with instruction sheet. One contact consists of outer contact, fluorocarbon dielectric, inner contact and shield crimp sleeve. Inner and outer contacts are gold-plated copper alloy. Approved to SAE AS39029. VSWR rating 1.5:1 maximum up to 700 MHz. 5000 megohm insulation resistance. Mates with: M39029/76.

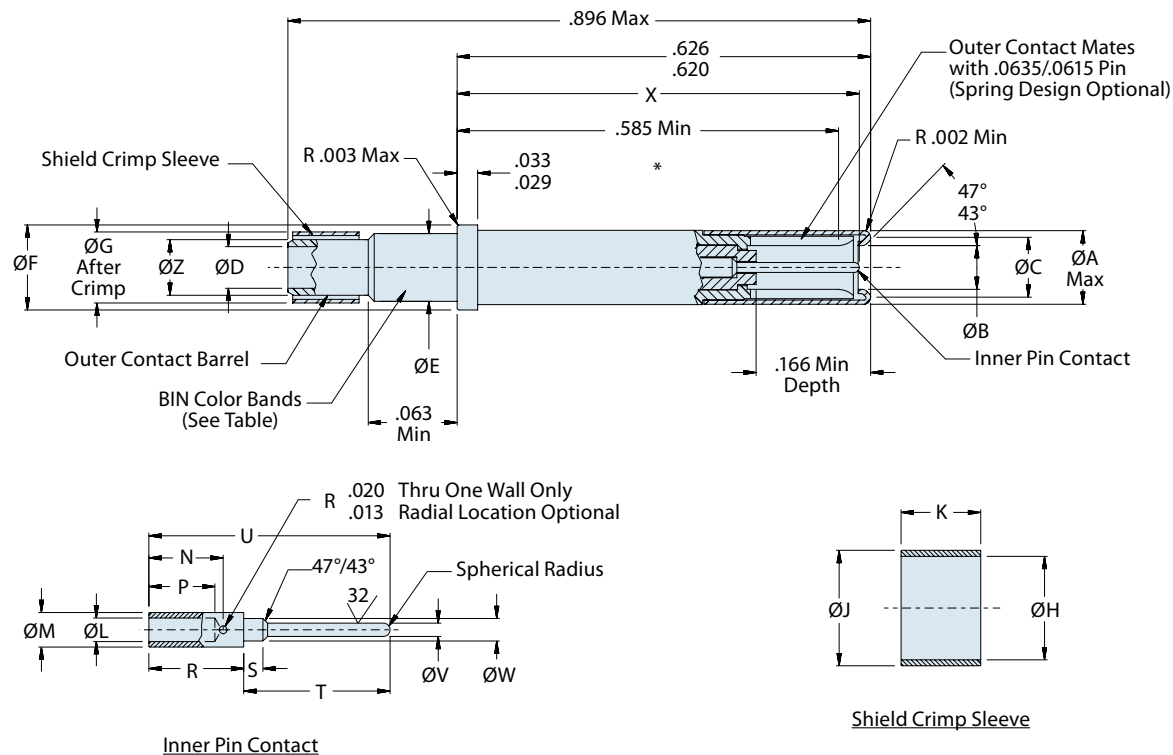
Material and Finish

Contact Body: Copper Alloy/Gold Plated
 Hood: Stainless Steel/Passivated
 Center Contact: Copper Alloy/Gold Plated
 Crimp Sleeve: Copper Alloy/Gold Plated
 Insulator: Teflon

* Indicates point at which a square ended pin of the same basic diameter as the mating contact first engages the outer contact spring

M39029/77
852-009
Size 16 Coaxial Socket



Type	Cable Accommodation	Part Number	Military Part Number	Color Band		
				1st	2nd	3rd
Socket	M17/119-RG174, M17/113-RG316, M17/094-RG179, Times AA3248, Teledyne 11299, Haveg 8100207, Thermax 75-738-BCCWXE, Tensolite 30888/L707YX-1	852-009-16-428	M39029/77-428	Yellow	Red	Gray
	M17/093-RG178	852-009-16-429	M39029/77-429	Yellow	Red	White
	Haveg 61-02051, Revere WH95623	852-009-16-430	M39029/77-430	Yellow	Orange	Black
	Haveg 30-00761, Haveg 30-02024, Haveg 30-02033, Tensolite 24713/A955KK1, Tensolite 26723/A955KK1	852-009-16-431	M39029/77-431	Yellow	Orange	Brown

BIN Code	ØA Max	ØB	ØC	ØD Min	ØE	ØF	ØG Max	ØH Min	ØJ Max	K	ØL Min
428	.113 (2.9)	.068 (1.73) .065 (1.65)	.089 (2.3) .084 (2.1)	.670 (17.0)	.103 (2.62) .101 (2.57)	.130 (3.3) .127 (3.2)	.108 (2.7)	.105 (2.7)	.120 (3.0)	.105 (2.7) .095 (2.4)	.0210 (0.5)
429	.113 (2.9)	.068 (1.73) .065 (1.65)	.089 (2.3) .084 (2.1)	0.575 (14.6)	.103 (2.62) .101 (2.57)	.130 (3.3) .127 (3.2)	.108 (2.7)	.094 (2.4)	.120 (3.0)	.105 (2.7) .095 (2.4)	.0210 (0.5)
430	.113 (2.9)	.068 (1.73) .065 (1.65)	.089 (2.3) .084 (2.1)	.670 (17.0)	.103 (2.62) .101 (2.57)	.130 (3.3) .127 (3.2)	.108 (2.7)	.105 (2.7)	.120 (3.0)	.105 (2.7) .095 (2.4)	.0355 (0.9)
431	.113 (2.9)	.068 (1.73) .065 (1.65)	.089 (2.3) .084 (2.1)	0.575 (14.6)	.103 (2.62) .101 (2.57)	.130 (3.3) .127 (3.2)	.108 (2.7)	.094 (2.4)	.120 (3.0)	.105 (2.7) .095 (2.4)	.0270 (0.7)

BIN Code	ØM Max	N Min	P	R	S	T	U Ref	ØV	ØW	X	ØZ Max
428	.046 (1.2)	.103 (2.6)	.094 (2.4) .087 (2.2)	.125 (3.2) .119 (3.0)	.079 (2.0) .073 (1.9)	.269 (6.83) .266 (6.76)	.3895 (9.9)	.0155 (.39) .0145 (.37)	.030 (0.8) .028 (0.7)	.611 (15.5) .601 (15.3)	.085 (2.2)
429	.046 (1.2)	.103 (2.6)	.094 (2.4) .087 (2.2)	.125 (3.2) .119 (3.0)	.079 (2.0) .073 (1.9)	.269 (6.83) .266 (6.76)	.3895 (9.9)	.0155 (.39) .0145 (.37)	.030 (0.8) .028 (0.7)	.611 (15.5) .601 (15.3)	.076 (1.9)
430	0.052 (1.3)	.103 (2.6)	.094 (2.4) .087 (2.2)	.125 (3.2) .119 (3.0)	.079 (2.0) .073 (1.9)	.269 (6.83) .266 (6.76)	.3895 (9.9)	.0155 (.39) .0145 (.37)	.030 (0.8) .028 (0.7)	.611 (15.5) .601 (15.3)	.085 (2.2)
431	.046 (1.2)	.103 (2.6)	.094 (2.4) .087 (2.2)	.125 (3.2) .119 (3.0)	.079 (2.0) .073 (1.9)	.269 (6.83) .266 (6.76)	.3895 (9.9)	.0155 (.39) .0145 (.37)	.030 (0.8) .028 (0.7)	.611 (15.5) .601 (15.3)	.076 (1.9)

Inner Contact		Outer Contact		Insertion Tool	Extraction Tool
Basic Crimping Tool	Positioner	Basic Crimping Tool	Positioner		
M22520/2-01	M22520/2-35	M22520/4-01	M22520/4-02	M81969/8-07 or M81969/14-03	M81969/8-08 or M81969/14-03

D38999
 Series II

Size #16 Coaxial Socket Contacts for MIL-DTL-38999 Series II Connectors

These #16 socket contacts accept 50 ohm and 75 ohm coaxial cable. Inner contact is rated at 1 amp, the outer contact 12 amps. DWV rating is 800 Vac rms sea level, 250 Vac at 50,000 feet. Contacts are packaged individually and are unassembled with instruction sheet. One contact consists of outer contact, fluorocarbon dielectric, inner contact and shield crimp sleeve. Inner and outer contacts are gold-plated copper alloy. Approved to SAE AS39029. VSWR rating 1.5:1 maximum up to 700 MHz. 5000 megohm insulation resistance. Mates with: M39029/76.

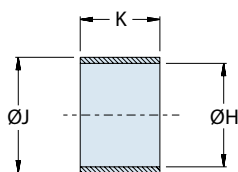
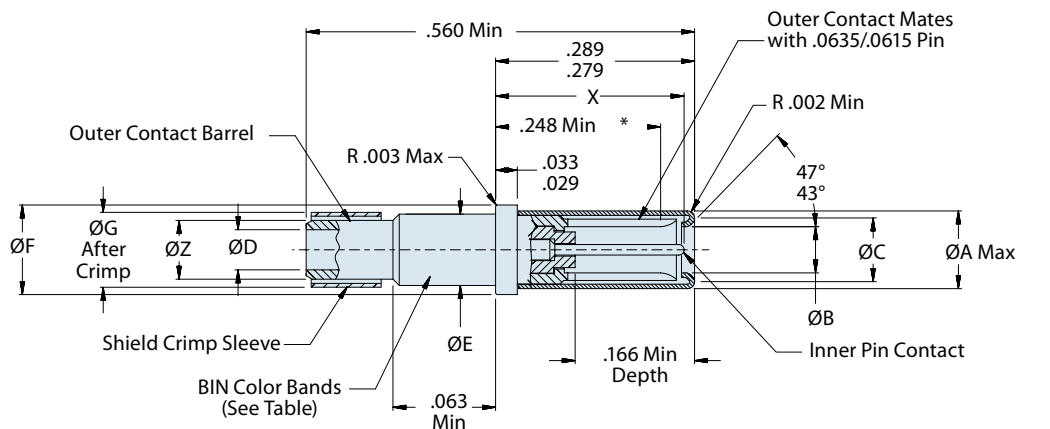
B

Shield Crimp Sleeve

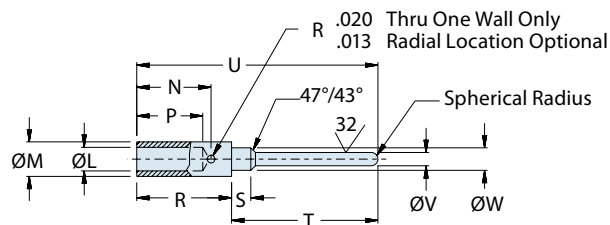

Inner Pin Contact

Material and Finish

Contact Body: Copper Alloy/Gold Plated
 Hood: Stainless Steel/Passivated
 Center Contact: Copper Alloy/Gold Plated
 Crimp Sleeve: Copper Alloy/Gold Plated
 Insulator: Teflon

* Indicates point at which a square ended pin of the same basic diameter as the mating contact first engages the outer contact spring

M39029/78
852-010
Size 16 Coaxial Socket



Type	Cable Accommodation	Part Number	Military Part Number	Color Band		
				1st	2nd	3rd
Socket	M17/119-RG174, M17/113-RG316, M17/094-RG179, Times AA3248, Teledyne 11299, Haveg 8100207, Thermax 75-738-BCCWXE, Tensolite 3088/L707YX-1	852-010-16-432	M39029/78-432	Yellow	Orange	Red
	M17/093-RG178	852-010-16-433	M39029/78-433	Yellow	Orange	Orange
	Haveg 61-02051, Revere WH95623	852-010-16-434	M39029/78-434	Yellow	Orange	Yellow
	Haveg 30-00761, Haveg 30-02024, Haveg 30-02033, Tensolite 24713/A955KK1, Tensolite 26723/A955K1	852-010-16-435	M39029/78-435	Yellow	Orange	Green

BIN Code	ØA Max	ØB	ØC	ØD Min	ØE	ØF	ØG Max	ØH Min	ØJ Max	K	ØL Min
432	.113 (2.9)	.068 (1.73) .065 (1.65)	.089 (2.3) .084 (2.1)	.670 (17.0)	.103 (2.62) .101 (2.57)	.130 (3.3) .127 (3.2)	.108 (2.7)	.105 (2.7)	.120 (3.0)	.105 (2.7) .095 (2.4)	.0210 (0.5)
433	.113 (2.9)	.068 (1.73) .065 (1.65)	.089 (2.3) .084 (2.1)	0.575 (14.6)	.103 (2.62) .101 (2.57)	.130 (3.3) .127 (3.2)	.108 (2.7)	.094 (2.4)	.120 (3.0)	.105 (2.7) .095 (2.4)	.0210 (0.5)
434	.113 (2.9)	.068 (1.73) .065 (1.65)	.089 (2.3) .084 (2.1)	.670 (17.0)	.103 (2.62) .101 (2.57)	.130 (3.3) .127 (3.2)	.108 (2.7)	.105 (2.7)	.120 (3.0)	.105 (2.7) .095 (2.4)	.0355 (0.9)
435	.113 (2.9)	.068 (1.73) .065 (1.65)	.089 (2.3) .084 (2.1)	0.575 (14.6)	.103 (2.62) .101 (2.57)	.130 (3.3) .127 (3.2)	.108 (2.7)	.094 (2.4)	.120 (3.0)	.105 (2.7) .095 (2.4)	.0270 (0.7)

BIN Code	ØM Max	N Min	P	R	S	T	U Ref	ØV	ØW	X	ØZ Max
432	.046 (1.2)	.103 (2.6)	.094 (2.4) .087 (2.2)	.125 (3.2) .119 (3.0)	.079 (2.0) .073 (1.9)	.269 (6.83) .266 (6.76)	.3895 (9.9)	.0155 (.39) .0145 (.37)	.030 (0.8) .028 (0.7)	.274 (7.0) .264 (6.7)	.085 (2.2)
433	.046 (1.2)	.103 (2.6)	.094 (2.4) .087 (2.2)	.125 (3.2) .119 (3.0)	.079 (2.0) .073 (1.9)	.269 (6.83) .266 (6.76)	.3895 (9.9)	.0155 (.39) .0145 (.37)	.030 (0.8) .028 (0.7)	.274 (7.0) .264 (6.7)	.076 (1.9)
434	0.052 (1.3)	.103 (2.6)	.094 (2.4) .087 (2.2)	.125 (3.2) .119 (3.0)	.079 (2.0) .073 (1.9)	.269 (6.83) .266 (6.76)	.3895 (9.9)	.0155 (.39) .0145 (.37)	.030 (0.8) .028 (0.7)	.274 (7.0) .264 (6.7)	.085 (2.2)
435	.046 (1.2)	.103 (2.6)	.094 (2.4) .087 (2.2)	.125 (3.2) .119 (3.0)	.079 (2.0) .073 (1.9)	.269 (6.83) .266 (6.76)	.3895 (9.9)	.0155 (.39) .0145 (.37)	.030 (0.8) .028 (0.7)	.274 (7.0) .264 (6.7)	.076 (1.9)

Inner Contact		Outer Contact		Insertion Tool	Extraction Tool
Basic Crimping Tool	Positioner	Basic Crimping Tool	Positioner		
M22520/2-01	M22520/2-35	M22520/4-01	M22520/4-02	M81969/8-07 or M81969/14-03	M81969/8-08 or M81969/14-03



M39029/90
853-001
Size 8 Concentric Twinax Pin

D38999

Ser. I, II, III, IV

**Size #8 Concentric Twinax Pin for MIL-DTL-38999 Series I, II, III and IV Connectors
(Inactive for New Design—Replaced by M39029/113)**



These #8 concentric twinax pin contacts accept MIL-STD-1553 data bus twinax cable. Center and intermediate contacts are rated at 1 amp, the outer contact 12 amps. DWV rating is 500 Vac rms sea level, 125 Vac at 70,000 feet. Operating frequency is 0-20 MHz. Contacts are packaged individually and shipped unassembled with instruction sheet. One contact consists of outer contact, fluorocarbon dielectric, inner contact, intermediate contact and shield crimp bushing. All contacts are gold-plated copper alloy. Approved to SAE AS39029. 5000 megohm insulation resistance. Mates with: M39029/91.

B

Type	Cable Accommodation	Part Number	Military Part Number	Color Band		
				1st	2nd	3rd
Pin	M17/176-00002	853-001-08-529	M39029/90-529	Green	Red	White

M39029/91
853-002
Size 8 Concentric Twinax Socket



D38999
Ser. I, III, IV

**Size #8 Concentric Twinax Socket for MIL-DTL-38999 Series I, III and IV Connectors
(Inactive for New Design—Replaced by M39029/114)**



These #8 concentric twinax socket contacts accept MIL-STD-1553 data bus twinax cable. Center and intermediate contacts are rated at 1 amp, the outer contact 12 amps. DWV rating is 500 Vac rms sea level, 125 Vac at 70,000 feet. Operating frequency is 0-20MHz. Contacts are packaged individually and shipped unassembled with instruction sheet. One contact consists of outer contact, fluorocarbon dielectric, inner contact, intermediate contact and shield crimp bushing. All contacts are gold-plated copper alloy. Approved to SAE AS39029. 5000 megohm insulation resistance. Mates with: M39029/90.

B

Type	Cable Accommodation	Part Number	Military Part Number	Color Band		
				1st	2nd	3rd
Socket	M17/176-00002	853-002-08-530	M39029/91-530	Green	Orange	Black

D38999
 Ser. I, III, IV

Size #8 Concentric Twinax Pin for MIL-DTL-38999 Series I, III and IV Connectors

These #8 concentric twinax pin contacts accept MIL-STD-1553 data bus twinax cable. Center and intermediate contacts are rated at 1 amp, the outer contact 12 amps. DWV rating is 500 Vac rms sea level, 125 Vac at 70,000 feet. Operating frequency is 0-20 MHz. Contacts are packaged individually and shipped unassembled with instruction sheet. One contact consists of outer contact, fluorocarbon dielectric, inner contact, intermediate contact and shield crimp bushing. All contacts are gold-plated copper alloy. Approved to SAE AS39029. 5000 megohm insulation resistance. Mates with: M39029/114.

Type	Cable Accommodation	Part Number	Military Part Number	Color Band		
				1st	2nd	3rd
Pin	M17/176-00002	853-003-08-625	M39029/113-625	Blue	Red	Green

Table II - Tool
 (Insertion and Extraction)

M81969/14-12

Table III Tools (Crimping)

Center Contact Tooling		Intermediate Contact Tooling		Outer Crimp Sleeve Tooling	
Basic Crimping Tool	Contact Positioner	Basic Crimping Tool	Die Part No.	Basic Crimping	Die Part No.
M22520/2-01	M22520/2-37	M22520/5-01	M22520/5-105 Cavity B	M22520/5-01	M22520/5-105 Cavity A

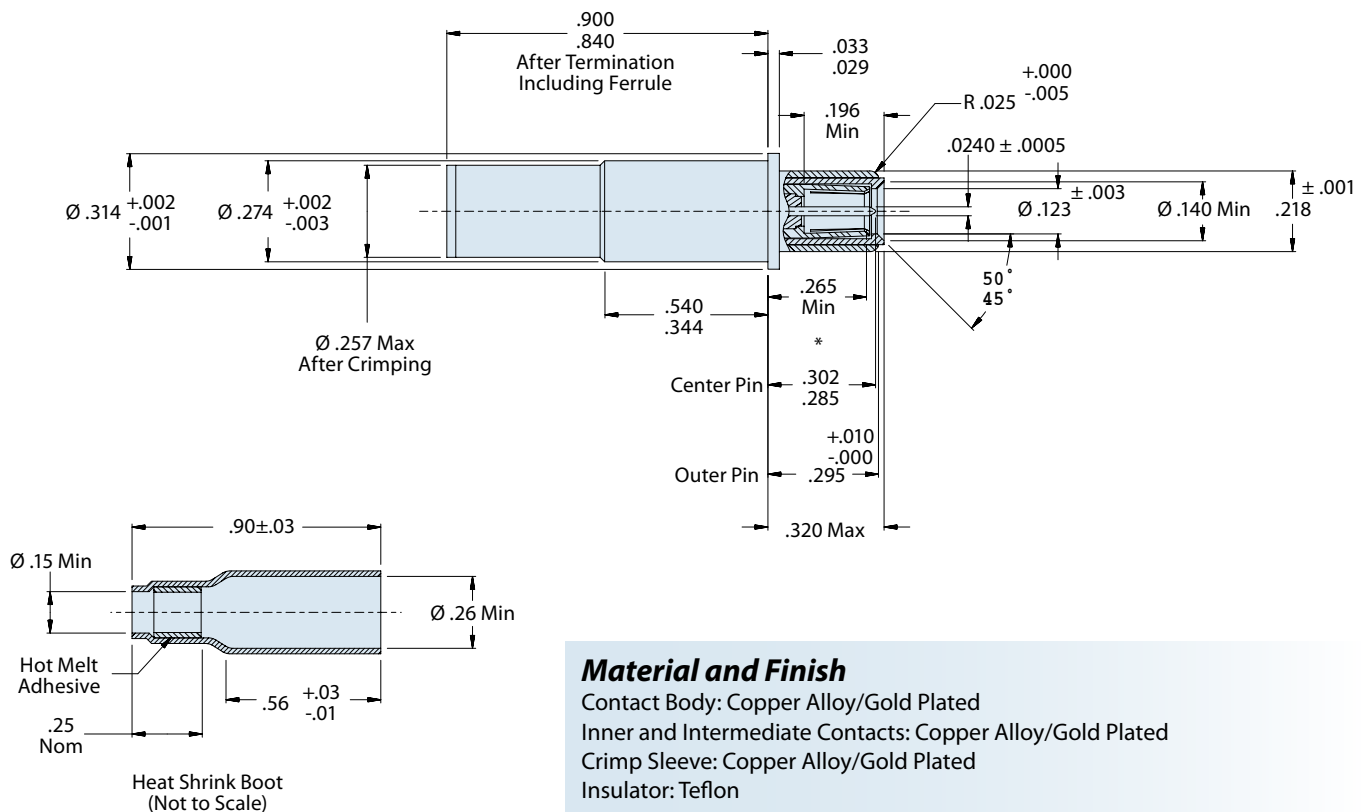

M39029/114
853-004
Size 8 Concentric Twinax Socket



D38999
 Ser. I, III, IV

Size #8 Concentric Twinax Socket for MIL-DTL-38999 Series I, III and IV Connectors



These #8 concentric twinax socket contacts accept MIL-STD-1553 data bus twinax cable. Center and intermediate contacts are rated at 1 amp, the outer contact 12 amps. DWV rating is 500 Vac rms sea level, 125 Vac at 70,000 feet. Operating frequency is 0-20 MHz. Contacts are packaged individually and shipped unassembled with instruction sheet. One contact consists of outer contact, fluorocarbon dielectric, inner contact, intermediate contact and shield crimp bushing. All contacts are gold-plated copper alloy. Approved to SAE AS39029. 5000 megohm insulation resistance. Mates with: M39029/113.

Type	Cable Accommodation	Part Number	Military Part Number	Color Band		
				1st	2nd	3rd
Socket	M17/176-00002	853-004-08-628	M39029/114-628	Blue	Red	Violet

B

Table II - Tool (Insertion and Extraction)
M81969/14-12

Table III Tools (Crimping)					
Center Contact Tooling		Intermediate Contact Tooling		Outer Crimp Sleeve Tooling	
Basic Crimping Tool	Contact Positioner	Basic Crimping Tool	Die Part No.	Basic Crimping	Die Part No.
M22520/2-01	M22520/2-37	M22520/5-01	M22520/5-105	M22520/5-01	M22520/5-105

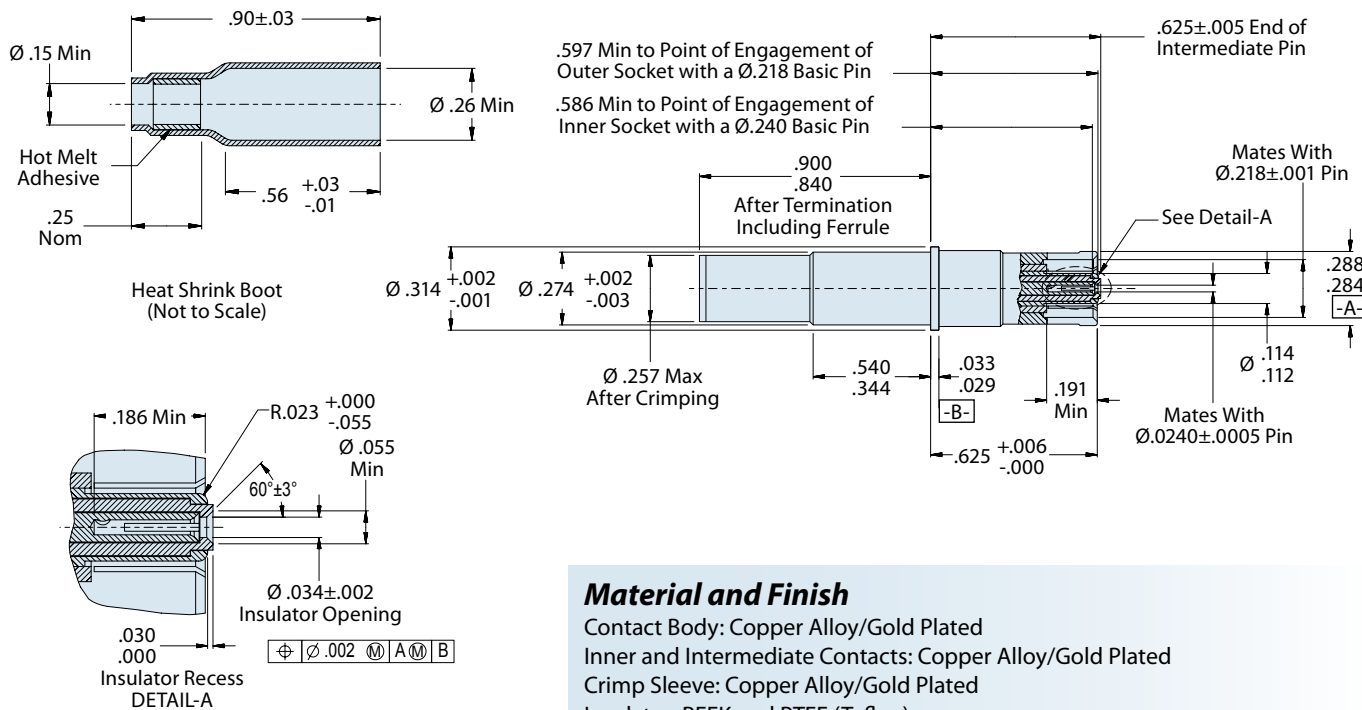



854-001

Crimp Quadrax Pin Contact MIL-DTL-38999 Series III Type

D38999
Series III

Size #8 Quadrax Pin Contact for Glenair 257-606 Connectors (D38999 Ser. III Type)



These #8 quadrax pin contacts accept 100 ohm quadrax cable. Center contacts are rated at 1 amp, the outer contact 12 amps. DWV rating is 500 Vac rms sea level, 125 Vac at 70,000 feet. Contacts are packaged individually and shipped unassembled with instruction sheet. One contact consists of outer contact, fluorocarbon dielectric, inner contacts and shield crimp bushing. All contacts are gold-plated copper alloy. 5000 megohm insulation resistance at 200Vdc. Mates with: 854-002. Ideally suited for up to 1000 Base-T gigabit ethernet.

B

Type	Glenair Part Number	Military Part Number	Cable Accommodation	Grommet Follower	Cable O.D.	"A" Hex	Wire Size
Pin	854-001-01	N/A	Tensolite NF26Q100	687-754-8-1	.137	.218	26 AWG
	854-001-02	N/A	Tensolite NF24Q100	687-754-8-2	.163	.218	24 AWG
	854-001-03	N/A	Draka Fileca F-4704-6	687-754-8-3	.153	.218	26 AWG
	854-001-04	N/A	Draka Fileca F-4704-4	687-754-8-4	.175	.218	24 AWG
	854-001-05	N/A	Tensolite NF22Q100	687-754-8-5	.190	.231	22 AWG

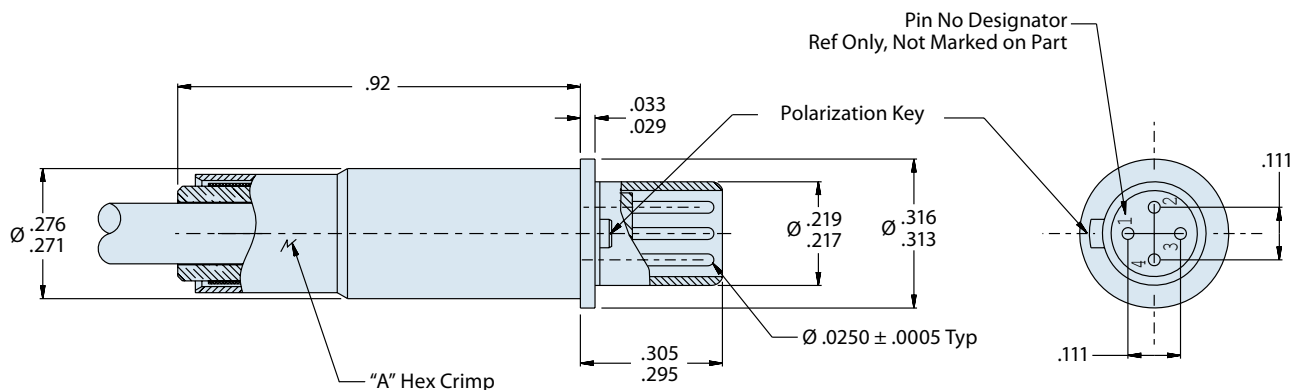

Material and Finish

Contact Body: Copper Alloy/Gold Plated
 Inner Contact: Copper Alloy/Gold Plated
 Crimp Bushing: Brass or equivalent/Gold Plated
 Insulator: Teflon, Ultem Series 1000 or equivalent
 Grommet/Follower: Fluorosilicone/Ultem 1000 or equivalent

854-002
Crimp Quadrax Socket Contact
 MIL-DTL-38999 Series III Type



Size #8 Quadrax Socket Contact for Glenair 257-606 Connectors (D38999 Ser. III Type)



These #8 quadrax socket contacts accept 100 ohm quadrax cable. Center contacts are rated at 1 amp, the outer contact 12 amps. DWV rating is 500 Vac rms sea level, 125 Vac at 70,000 feet. Contacts are packaged individually and shipped unassembled with instruction sheet. One contact consists of outer contact, fluorocarbon dielectric, inner contacts and shield crimp bushing. All contacts are gold-plated copper alloy. 5000 megohm insulation resistance at 200Vdc. Mates with: 854-001. Ideally suited for up to 1000 Base-T gigabit ethernet.

Type	Glenair Part Number	Military Part Number	Cable Accommodation	Grommet Follower	Ref Cable O.D.	"A" Hex	Wire Size
Socket	854-002-01	N/A	Tensolite NF26Q100	687-754-8-1	.137	.218	26 AWG
	854-002-02	N/A	Tensolite NF24Q100	687-754-8-2	.163	.218	24 AWG
	854-002-03	N/A	Draka Fileca F-4704-6	687-754-8-3	.153	.218	26 AWG
	854-002-04	N/A	Draka Fileca F-4704-4	687-754-7-4	.175	.218	24 AWG
	854-002-05	N/A	Tensolite NF22Q100	687-754-8-5	.190	.231	22 AWG

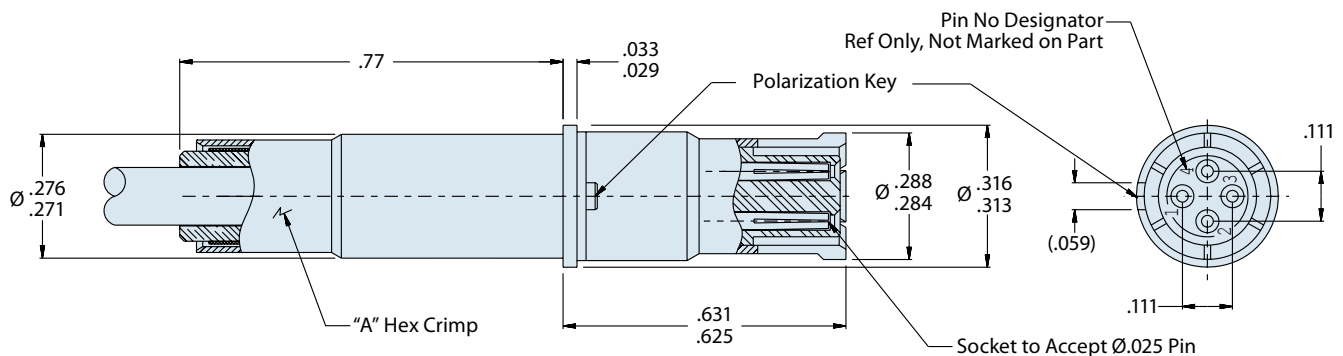

Material and Finish

Contact Body: Copper Alloy/Gold Plated
 Inner Contact: Copper Alloy/Gold Plated
 Crimp Bushing: Brass or equivalent/Gold Plated
 Insulator: Teflon, Ultem Series 1000 or equivalent
 Grommet/Follower: Fluorosilicone/Ultem 1000 or equivalent

Size #12 Differential Twinax Socket Contact for Multi-Gigabit Data Rate Applications

These solder terminated #12 twinax socket contacts accept 100 ohm twinax cable. Current rating is 1 Amp. DWV rating is 500 Vac rms sea level, 125 Vac at 70,000 feet. Contacts are packaged individually and shipped unassembled with instruction sheet. One contact consists of outer contact and center contact. All contacts are gold-plated copper alloy. 5000 megohm insulation resistance at 200Vdc. Mates with: 853-016. Ideally suited for multi-gigabit data rate applications such as 1000 Base-T gigabit ethernet.

Type	Glenair Part No.	Military Part No.	AWG Wire Size	Cable Accommodation	Impedance	Frequency Range	VSWR	Insertion Loss
Socket	853-015-01	N/A	30	963-102-30	100-Ohms Nominal	DC to 10 GHz	1.1 + (.03 * F GHz)	1/3 * F GHz

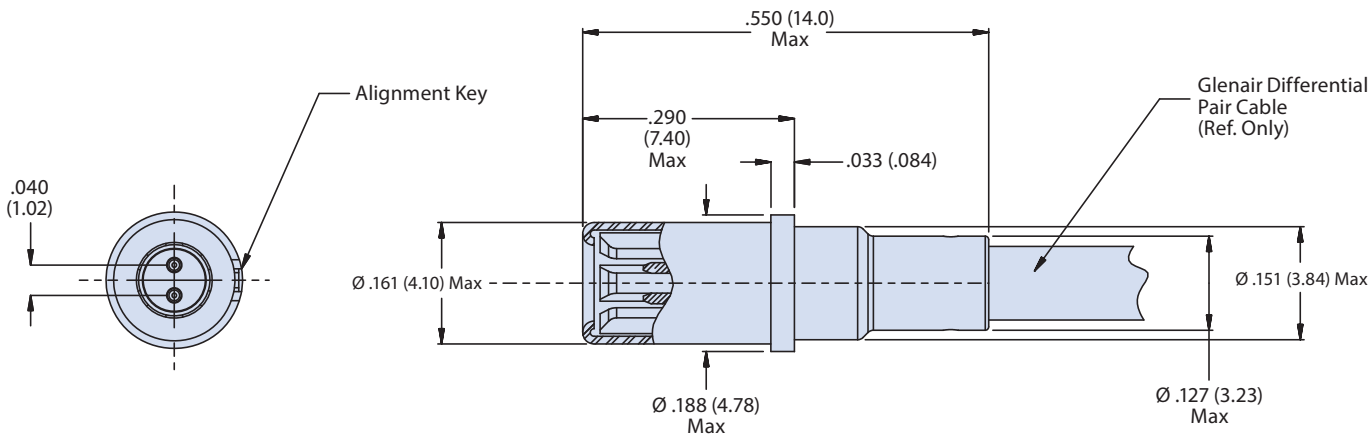
Material and Finish

Contact Body: Copper Alloy/Gold Plated
 Center Contact: Copper Alloy/Gold Plated

Electrical Parameters

Differential Impedance: 100-ohms nominal
 Frequency Range: DC to 10 GHz
 VSWR: 1.1+(.03* F GHz)
 Insertion Loss: 1/3* F GHz
 Dielectric Withstanding Voltage: 500 Vrms
 Insulation Resistance: 5000 Megohms minimum

Notes

Contact is designed to accommodate Glenair P/N 963-102-30 cable.
 For assembly instructions, see AI85014.
 Socket contact shall mate with Glenair Pin Contact P/N 853-016-XX.
 For use in Glenair Mighty Mouse and Series 79 Micro-Crimp connectors only.
 PCB Tail-equipped contacts also available. Consult factory.

Designed for use with 853-015-01

963-102-30

Differential Pair Cable



853-016

Size #12 Differential Twinax Pin Contact
For Use with Mighty Mouse and Series 79 Micro-Crimp



Shielded
Contacts

Size #12 Differential Twinax Pin Contact for Multi-Gigabit Data Rate Applications

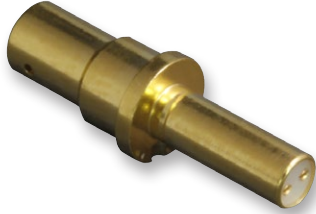

These solder terminated #12 twinax pin contacts accept 100 ohm twinax cable. Current rating is 1 Amp. DWV rating is 500 Vac rms sea level, 125 Vac at 70,000 feet. Contacts are packaged individually and shipped unassembled with instruction sheet. One contact consists of outer contact and center contact. All contacts are gold-plated copper alloy. 5000 megohm insulation resistance at 200Vdc. Mates with: 853-015. Ideally suited for multi-gigabit data rate applications such as 1000 Base-T gigabit ethernet.

Type	Glenair Part No.	Military Part No.	AWG Wire Size	Cable Accommodation	Impedence	Frequency Range	VSWR	Insertion Loss
Pin	853-016-01	N/A	30	963-102-30	100-Ohms Nominal	DC to 10 GHz	1.1 + (.03 * F GHz)	1/3 *F GHz

B

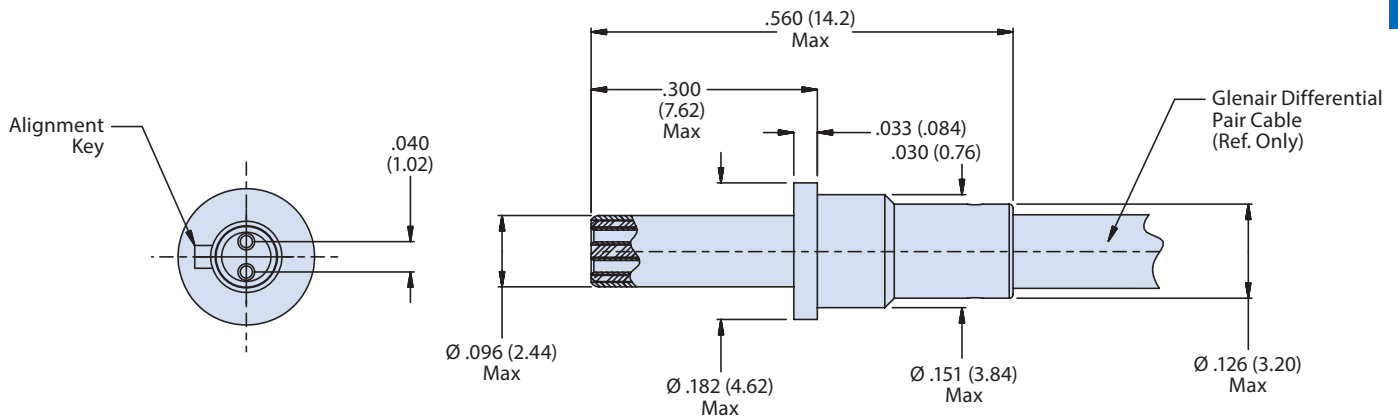

Material and Finish

Contact Body: Copper Alloy/Gold Plated
 Center Contact: Copper Alloy/Gold Plated

Electrical Parameters

Differential Impedence: 100-ohms nominal
 Frequency Range: DC to 10 Ghz
 VSWR: 1.1+(.03* F Ghz)
 Insertion Loss: 1/3* F Ghz
 Dielectric Withstanding Voltage: 500 Vrms
 Insulation Resistance: 5000 Megohms minimum

Notes

Contact is designed to accommodate Glenair P/N 963-102-30 cable.
 For assembly instructions, see AI85014.
 Pin contact shall mate with Glenair Socket Contact P/N 853-015-XX.
 For use in Glenair Mighty Mouse and Series 79 Micro-Crimp connectors only.
 PCB Tail-equipped contacts also available. Consult factory.

Designed for use with 853-016-01
963-102-30
Differential Pair Cable





AI85014 Twinax Socket Contact Assembly Instructions

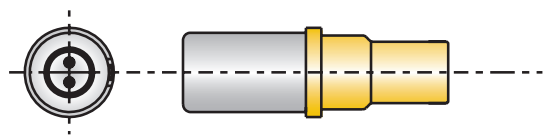

Socket Contact

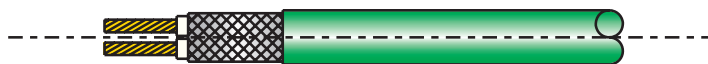

100 Ohm Parallel Cable

B

STEP 1

1. Strip cable to dimensions shown.
Be careful not to flare braid open.
2. Pre-tin conductor and braid shield.
3. Clean the solder joint with alcohol.

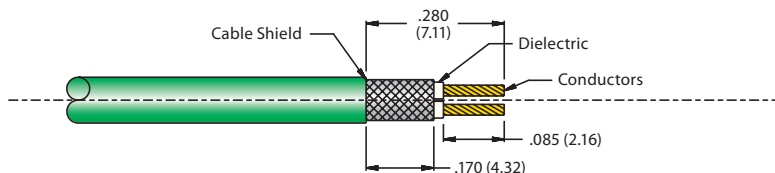

STEP 2

1. Insert cable into socket contact.
Make sure center conductor lines up to the center socket.



STEP 3

1. Install center conductors until they bottom-out in the contact cavity.
Inspect to ensure cable shield is visible through the inspection hole.
2. Apply flux and solder through the inspection hole; remove residues and contamination with alcohol after soldering.

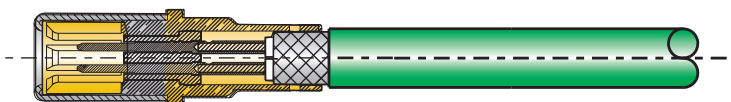

STEP 4

1. Install M23053/5-204 or M23053/6-204 shrink tubing; cover solder area and extend insulation by minimum of one wire diameter.

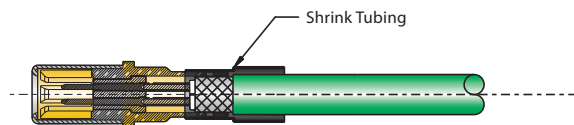

STEP 5

1. Illustrates final assembly.

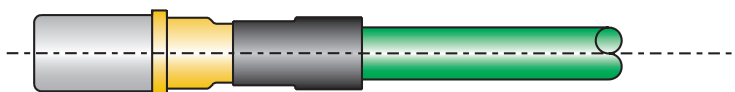

AI85015
Twinax Pin Contact
Assembly Instructions

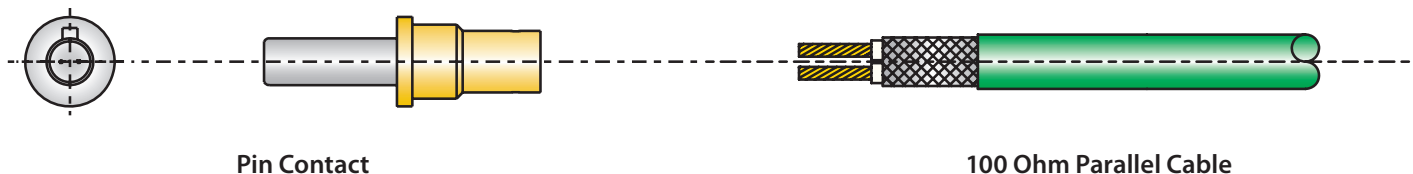

STEP 1	
<ol style="list-style-type: none"> Strip cable to dimensions shown. Be careful not to flare braid open. Pre-tin conductor and braid shield. Clean the solder joint with alcohol. 	
STEP 2	
<ol style="list-style-type: none"> Insert cable into pin contact. Make sure center conductor lines up to the center pin. 	
STEP 3	
<ol style="list-style-type: none"> Install center conductors until they bottom-out in the contact cavity. Inspect to ensure cable shield is visible through the inspection hole. Apply flux and solder through the inspection hole; remove residues and contamination with alcohol after soldering. 	
STEP 4	
<ol style="list-style-type: none"> Install M23053/5-204 or M23053/6-204 shrink tubing; cover solder area and extend insulation by minimum of one wire diameter. 	
STEP 5	
<ol style="list-style-type: none"> Illustrates final assembly. 	

B

SERIES 18

FIBER OPTICS

**Mission-Critical Interconnect Systems
for Commercial and Military Applications**



From our MIL-PRF-28876 type fiber optic connectors to our MIL-DTL-38999 type solutions, Glenair produces advanced performance fiber optic interconnection systems for every military and commercial standard. Fiber optic connectors, termini and cabling offer reduced weight, reduced size, huge bandwidth and EMI immunity— and Glenair manufactures a solution for every branch of the military and every mission-critical commercial application. For complete order information please see our fiber optic catalog or visit our website at www.glenair.com



QPL and Commercial High Performance Fiber Optic Termini

Industry Leading Fiber Optic Technology

Glenair Fiber Optic connection systems are well known throughout the aerospace and tactical military applications arena. Our fiber optic contacts are universally recognized to provide consistent performance with extremely low dB loss. We are the supplier of choice for some of the world's most advanced fiber optic systems, including the revolutionary F-35 Joint Strike Fighter.

Glenair offers the industry's widest range of contacts for both Mil-Spec and proprietary fiber optic connection systems. These highly-available contact termini are guaranteed to deliver outstanding interconnection compatibility. Glenair manufactures fiber optic termini for every popular Mil-Spec and commercial high-performance interconnection system, including the multi-channel MIL-DTL-38999 Series III. Our fiber optic termini deliver optimal performance in both our own connectors as well as those produced by other manufacturers. In fact, our MIL-PRF-29504 qualified fiber optic termini are often selected as much for their outstanding interconnection compatibility as for their ability to boost the optical performance of third party connectors.

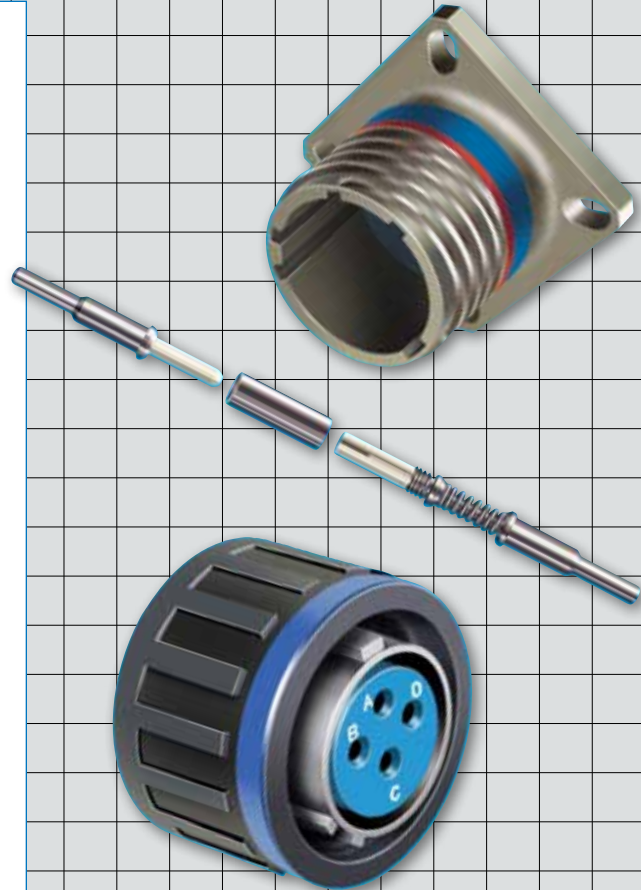

C

- ◆ Qualified and Commercial High-Performance, Low dB Loss Termini
- ◆ Same Day Inventory for Hundreds of Part Numbers
- ◆ Broadest Range of Mission-Critical Termini in the Mil-Aero Industry
- ◆ Myriad Material and Design Advantages



Fiber Optic Termini Selection Guide

Glenair Part Number	Part Description	Contact Size	Pin / Socket	Connector Series	Product Page
MIL-DTL-38999 Fiber Optic Contacts					
181-001	M29504/5 Socket Terminus	16	Socket	D38999 Series III	C-4
181-002	M29504/4 Pin Terminus	16	Pin	D38999 Series III	C-6
181-035	Socket, Large Core Fiber	16	Socket	D38999 Series III	C-8
181-036	Pin, Large Core Fiber	16	Pin	D38999 Series III	C-9
181-052	Jewel Pin Terminus	16	Pin	D38999 Series III	C-10
181-053	Jewel Socket Terminus	16	Socket	D38999 Series III	C-11
181-048	Sealing Plug	16	Pin	D38999 Series III	C-12
181-065	#20 Pin Terminus	20	Pin	D38999 Series III	C-13
181-066	#20 Socket Terminus	20	Socket	D38999 Series III	C-14
MIL-PRF-28876 Fiber Optic Contacts					
181-039	M29504/14 Pin Terminus	16	Pin	M28876	C-15
181-040	M29504/15 Socket Terminus	16	Socket	M28876	C-16
181-051	M29504/3 Dummy Terminus	16	Dummy	M28876	C-33
Series 80 Mighty Mouse Fiber Optic Contacts					
181-057	Mighty Mouse Pin Terminus	16	Pin	Series 80 Mighty Mouse	C-18
181-075	Mighty Mouse Socket Terminus	16	Socket	Series 80 Mighty Mouse	C-19

Fiber Optic Termini Selection Guide



Glenair Part Number	Part Description	Contact Size	Pin / Socket	Connector Series	Product Page
Special Fiber Optic COTS Contacts Size 16 Front Release					
181-011	Front Release Socket with Pressure Sealing O-Ring(s)	16	Socket	COTS	C-20
181-012	Front Release Pin	16	Pin	COTS	C-22
181-051	Dummy Terminus	16	Dummy	COTS	C-33
ARINC Type Fiber Optic Contacts					
181-076	ARINC 801 Terminus	16	Genderless Pin	ARINC 801	C-24
187-079	M29504/6 Pin Terminus	16	Pin	ARINC 404, 600	C-25
187-080	M29504/7 Socket Terminus	16	Socket	ARINC 404, 600	C-26
Glenair High Density (GHD) Fiber Optic Contacts					
181-056	GHD Terminus, Non-keyed	18	Genderless Pin	GHD	C-28
181-047	GHD Terminus, Keyed	18	Genderless Pin	GHD	C-30
181-058	Dummy Terminus	18	Dummy	GHD	C-32
Glenair GFOCA Fiber Optic Contacts					
181-050	GFOCA Terminus		Genderless Pin	GFOCA	C-34
181-059	Dummy Terminus		Dummy	GFOCA	C-36
Next Generation Fiber Optic (NGCON) Contacts					
181-043	M29504/18	16	Genderless Pin	M64266	C-37

Ultra low dB loss QPL'd Socket Terminus for MIL-DTL-38999



Glenair's unique alignment techniques maximize optical performance and provide reliable, repeatable interconnection of optical fibers. Ferrule design, critical to the performance of the termini, has traditionally relied on a machined stainless steel ferrule incorporating a precision micro drilled hole. Glenair's unique precision ceramic ferrules, with concentricity and diametric tolerances controlled within a micron (.00004 of an inch) meet the needs of high bandwidth and low allowable insertion loss applications. In fact, Glenair's ferrules are approximately 10 times more accurate than alternative designs, and have reduced insertion loss values from 1.5dB to less than .5dB (typical loss for Glenair termini is .3 dB).

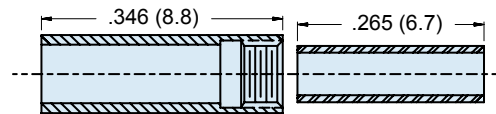

**Protective Cover Alignment Sleeve
(Included with Terminus)**

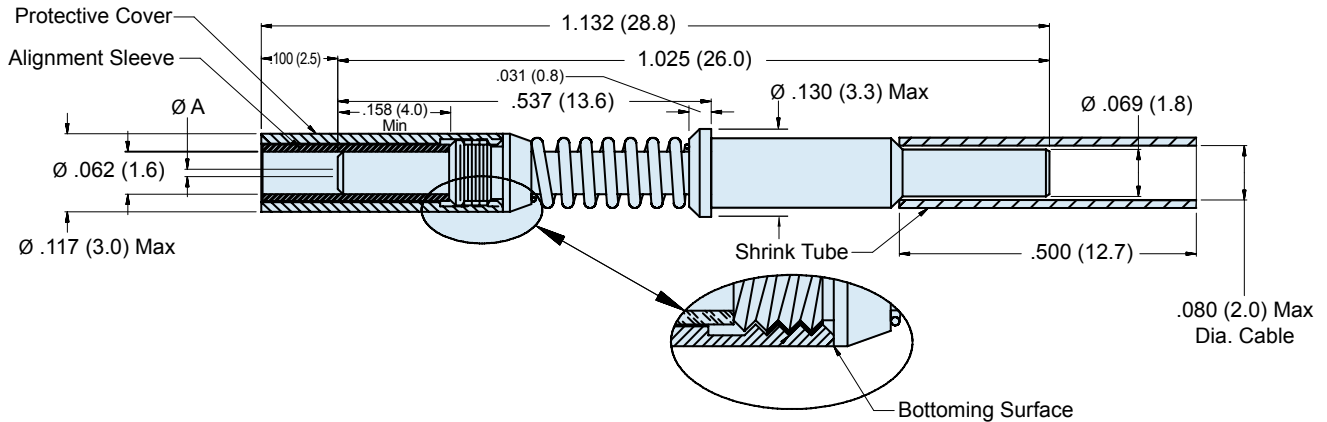

Material and Finish

Ferrule: Zirconia Ceramic
 Alignment Sleeve: Zirconia Ceramic or Stainless Steel/Passivate.
 Terminus Assembly: Stainless Steel/Passivate
 Spacer, Spring, and Cover: Stainless Steel/Passivate
 Shrink Tube: Kynar

Accessories

Alignment Sleeve & Protective Cover can also be ordered separately (Table II).

Assembly

See assembly procedure GAP-015 for complete termination instructions.
 Recommended insertion/Extraction tool: P/N: M81969/14-03 or equivalent

**M29504/5
181-001**
Size 16 MIL-DTL-38999 Type Fiber Optic Socket Terminus



Fiber Optic

Part Number	Fiber Size Core/Cladding*	A Dia. (Microns)	Reference Only M29504/5-XXXX
181-001-125	9/125 (Single Mode)	125.5	M29504/5-4237
181-001-126S	9/125 (Single Mode)	126.0	M29504/5-4238
181-001-126	50/125 & 62.5/125	126.0	M29504/5-4239
181-001-127	50/125 & 62.5/125	127.0	M29504/5-4046
181-001-142	100/140	142.0	M29504/5-4049
181-001-144	100/140	144.0	N/A
181-001-145	100/140	145.0	M29504/5-4050
181-001-156	62.5/125/155 (Polyimide)	156.0	M29504/5-4240
181-001-157	62.5/125/155 (Polyimide)	157.0	M29504/5-4241
181-001-173	100/140/172 (Polyimide)	173.0	M29504/5-4088
181-001-175	100/140/172 (Polyimide)	175.0	M29504/5-4242
181-001-231	200/230	231.0	N/A
181-001-236	200/233	236.0	M29504/5-4243
181-001-286	200/280	286.0	M29504/5-4244
181-001-448	400/440	448.0	M29504/5-4245
181-001-533	486/500	533.0	N/A

Ceramic alignment sleeve supplied with terminus. Add **K** to the end of part number development to supply with optional stainless steel alignment sleeve e.g. 181-001-126K.

C

Accessories	
Part Number	Description
181-001-S	Ceramic Alignment Sleeve
181-001-K	Stainless Steel Alignment Sleeve
181-001-C	Protective cover

D38999
Series III

Ultra Low dB loss QPL'd Pin Terminus for MIL-DTL-38999



Glenair's unique alignment techniques maximize optical performance and provide reliable, repeatable interconnection of optical fibers. Ferrule design, critical to the performance of the termini, has traditionally relied on a machined stainless steel ferrule incorporating a precision micro drilled hole. Glenair's unique precision ceramic ferrules, with concentricity and diametric tolerances controlled within a micron (.00004 of an inch) meet the needs of high bandwidth and low allowable insertion loss applications. In fact, Glenair's ferrules are approximately 10 times more accurate than alternative designs, and have reduced insertion loss values from 1.5dB to less than .5dB (typical loss for Glenair termini is .3 dB).

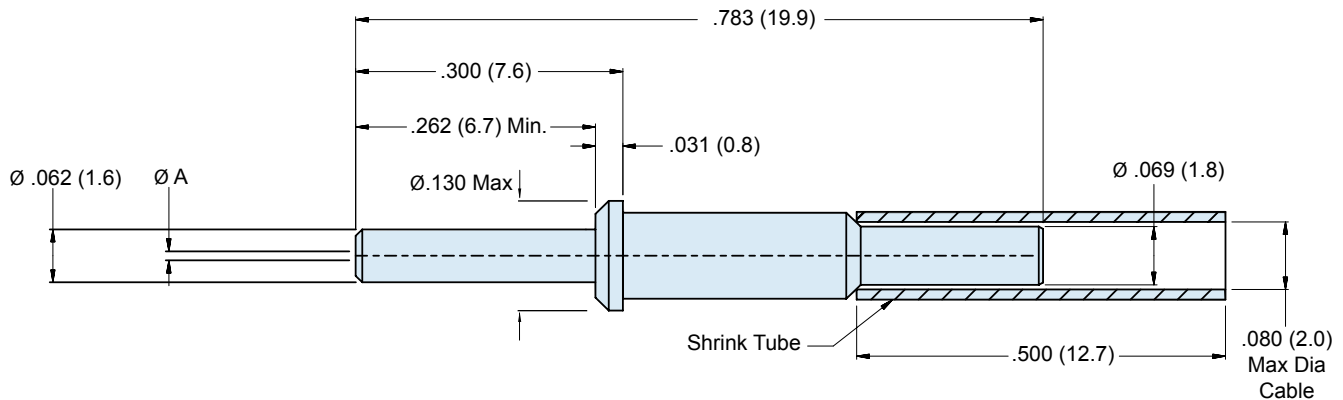

Material and Finish

Ferrule: Zirconia Ceramic

Terminus Assembly: Stainless Steel/Passivate

Shrink Tube: Kynar

Assembly

Recommended insertion/Extraction tool: P/N: M81969/14-03 or equivalent

See Glenair assembly procedure GAP-015 for complete termination instructions.

M29504/4
181-002
Size 16 MIL-DTL-38999 Type Fiber Optic Pin Terminus



Part Number	Fiber Size Core/Cladding*	A Dia. (Microns)	Reference Only M29504/4-XXXX
181-002-125	9/125 (Single Mode)	125.5	M29504/4-4208
181-002-126S	9/125 (Single Mode)	126.0	M29504/4-4209
181-002-126	50/125 & 62.5/125	126.0	M29504/4-4210
181-002-127	50/125 & 62.5/125	127.0	M29504/4-4040
181-002-142	100/140	142.0	M29504/4-4043
181-002-144	100/140	144.0	N/A
181-002-145	100/140	145.0	M29504/4-4044
181-002-156	62.5/125/155 (Polyimide)	156.0	M29504/4-4211
181-002-157	62.5/125/155 (Polyimide)	157.0	M29504/4-4212
181-002-173	100/140/172 (Polyimide)	173.0	M29504/4-4087
181-002-175	100/140/172 (Polyimide)	175.0	M29504/4-4213
181-002-231	200/230	231.0	N/A
181-002-236	200/233	236.0	M29504/4-4214
181-002-286	200/280	286.0	M29504/4-4215
181-002-448	400/440	448.0	M29504/4-4216
181-002-533	486/500	533.0	N/A

D38999
 Series III

Large Core Fiber Optic MIL-DTL-38999 Type Size 16 Socket Terminus



Part Number	Fiber Size Core/Cladding (Microns)	ØA (Microns)
181-035-600	600 Micron	610.0
181-035-1000	1000 Micron (Plastic)	1117.0

Ceramic alignment sleeve supplied with terminus. Add **K** to the end of part number development to supply with optional stainless steel alignment sleeve e.g. 181-035-1000K.

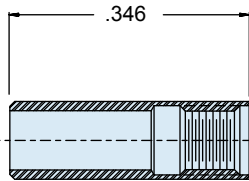
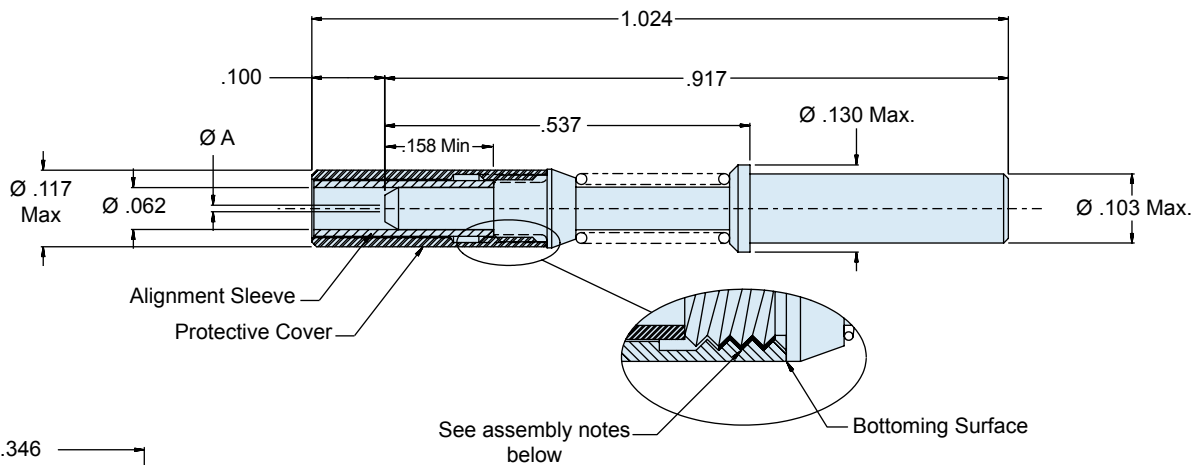
Accessories	
Part Number	Terminus Accessory
181-001-S	Ceramic Alignment Sleeve
181-001-K	Stainless Steel Alignment Sleeve
181-001-C	Protective Cover

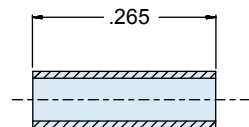

Protective Cover



Alignment Sleeve

Material and Finish

Ferrule: Stainless Steel/Passivate

Alignment Sleeve: Zirconia Ceramic or Stainless Steel/Passivate

Terminus Assembly: Stainless Steel/Passivate

Spacer, Spring, and Cover: Stainless Steel/Passivate

Tools and Accessories/Assembly Notes

Alignment sleeve and protective cover can also be ordered separately (see Table II)

Threaded Protective cover must be retained using Threadlocker "Loctite 222" prior to insertion and fully seated against terminus body as shown. See Glennair assembly procedure GAP-015 for complete termination instruction.

Recommended Insertion/Extraction Tool: P/N M81969/14-03 or equivalent

181-036
Large Core Optical Fiber Pin Terminus
MIL-DTL-38999 Type



Large Core Fiber Optic MIL-DTL-38999 Type Size 16 Pin Terminus



Part Number	Fiber Size Core/Cladding	ØA (Microns)
181-036-600	600 Micron	610.0
181-036-1000	1000 Micron (Plastic)	1117.0

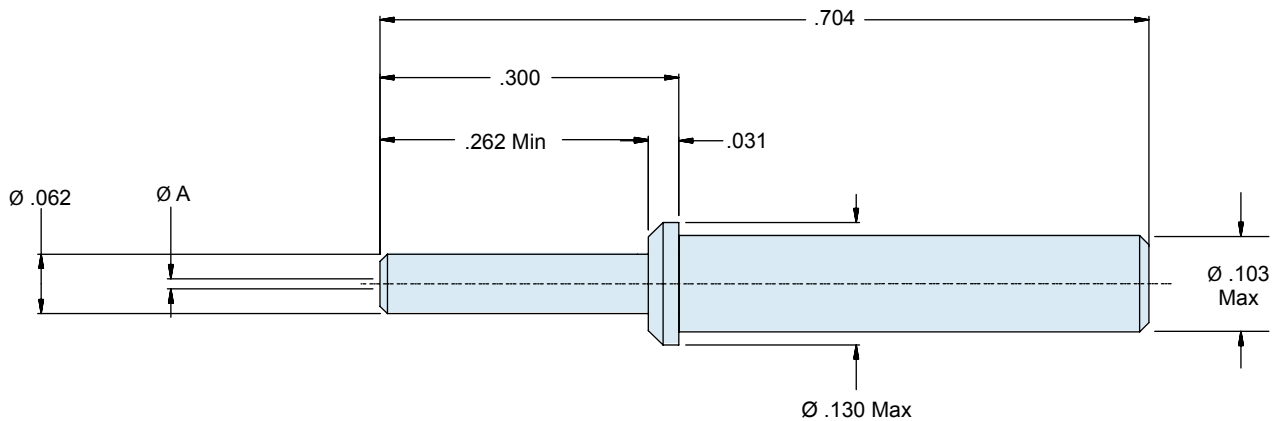

Material and Finish

Ferrule and Terminus Body: Stainless Steel/Passivate

Tools and Assembly Notes

Recommended Insertion/Extraction Tool: P/N M81969/14-03 or equivalent
 See Glenair Assembly Procedure GAP-015 for complete termination instruction.

D38999
 Series III

MIL-DTL-38999 Type Fiber Optic Jewel Pin Terminus

Part Number	Ferrule Hole Ø A (Microns)	Typical Fiber Size Core/Cladding/Coating (Microns)
181-052-125	125.0	9/125 (Single Mode)
181-052-127	127.0	50/125, 62.5/125
181-052-142	142.0	100/140
181-052-157	157.0	62.5/125/155
181-052-175	175.0	100/140/172
181-052-236	236.0	200/230

Add L to the end of part number development to supply less epoxy preforms e.g. 181-052-127L. Omit to include preforms.

Terminus Accessories

Part Number	Terminus Accessory
189-070-6	Reducing Sleeve Ø1.90mm Max Cable Jacket

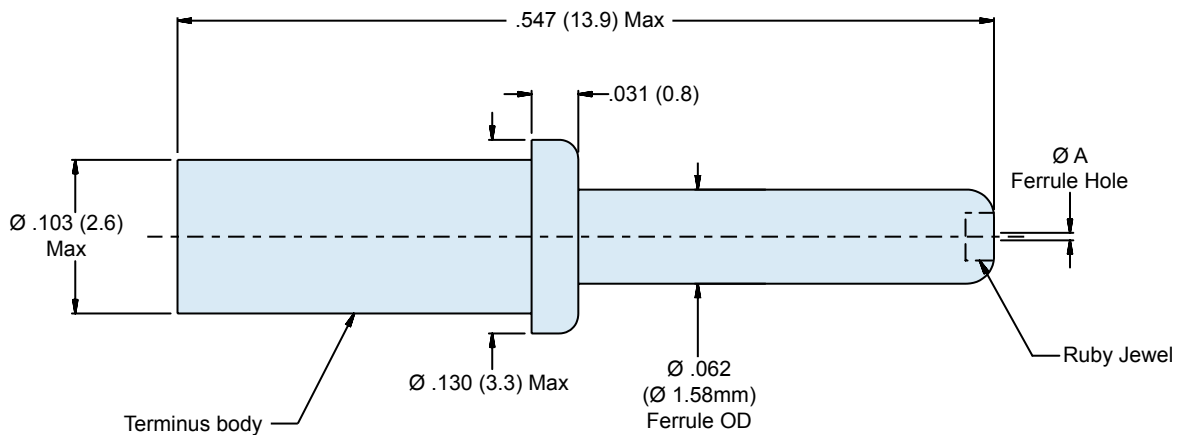
Material and Finish

Terminus Body: Stainless steel/passivate
 Jewel, Ruby: Synthetic ruby or sapphire

Assembly

Recommended insertion/extraction tool: M81969/14-03 or equivalent

181-053
Size 16 Fiber Optic Jewel Socket Terminus
MIL-DTL-38999 Type



Fiber Optic Jewel Socket Terminus for MIL-DTL-38999 Type Connectors



Part Number	Ferrule Hole Ø A (Microns)	Typical Fiber Size Core/Cladding/ Coating (Microns)
181-053-125	125.0	9/125 (Single Mode)
181-053-127	127.0	50/125, 62.5/125
181-053-142	142.0	100/140
181-053-157	157.0	62.5/125/155
181-053-175	175.0	100/140/172
181-053-236	236.0	200/230

Add **L** to the end of part number development to supply less epoxy preforms e.g. [181-053-127L](#). Omit to include preforms.

Terminus Accessories	
Part Number	Terminus Accessory
189-070-6	Reducing Sleeve Ø1.90mm Max Cable Jacket
189-075	Alignment Sleeve
182-031	Alignment Sleeve Installation Tool
182-032	Alignment Sleeve Extraction Tool

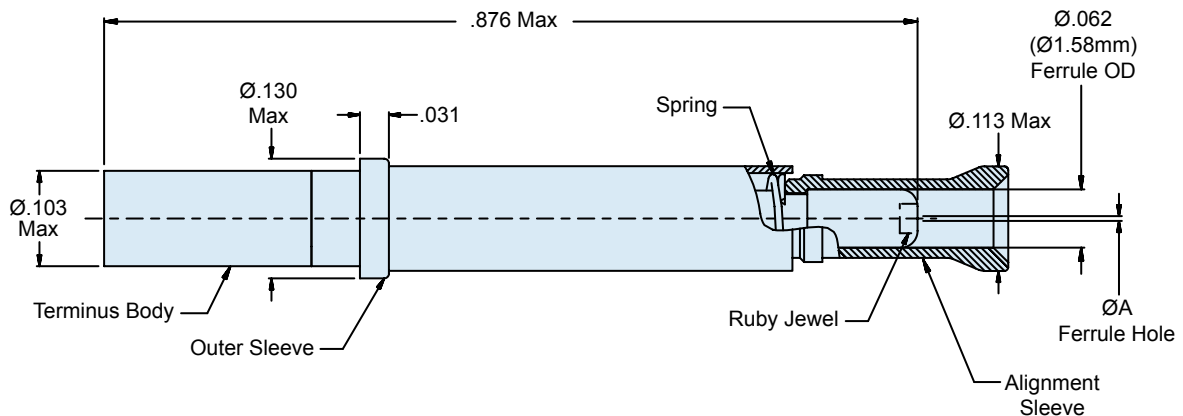

Material and Finish

Terminus Body: Stainless Steel/Passivate
 Jewel/Ruby: Synthetic Ruby or Sapphire
 Alignment Sleeve: Stainless Steel/Passivate
 Outer Sleeve: Stainless Steel/Passivate
 Spring: Stainless Steel/Passivate.

Accessories and Assembly Notes

Alignment Sleeve, Outer Sleeve, and Spring packaged loose with assembly.
 Recommended insertion/extraction tool: M81969/14-03 or equivalent.

181-048

Size 16 Fiber Optic Sealing Plug

For use with MIL-DTL-38999 Series III Type Connectors

D38999
Series III

Dummy Terminus designed to seal against the rear grommet and interfacial seal of MIL-DTL-38999 connectors.



Part Number	Description
181-048-16	Dummy Terminus, size 16

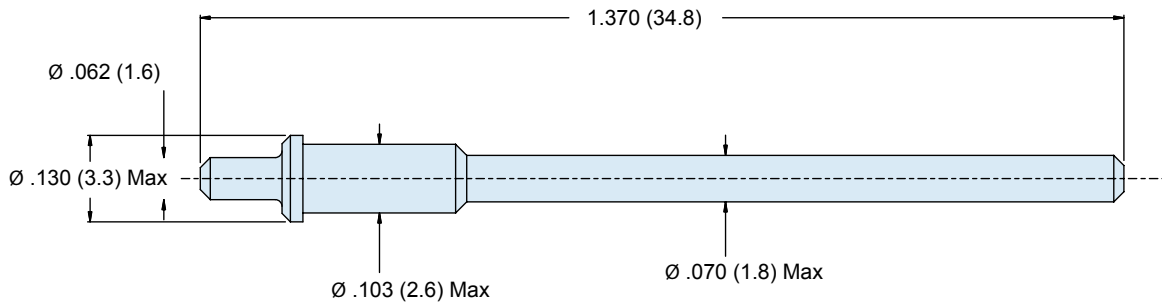

Material and Finish

Terminus: High Grade Engineering Thermoplastic

Assembly

Recommended insertion/extraction tool: P/N: M81969/14-03 or equivalent

181-065
Size 20 Pin Terminus
MIL-DTL-38999 Type



MIL-DTL-38999 Type Size 20 Pin Terminus



Part Number	Fiber Size Core/Cladding (Microns)	Typ. Fiber Type	ØA (Microns)
181-065-1255	9/125	Single Mode	125.5
181-065-126	50/125 62.5/125	Multi Mode	126.0

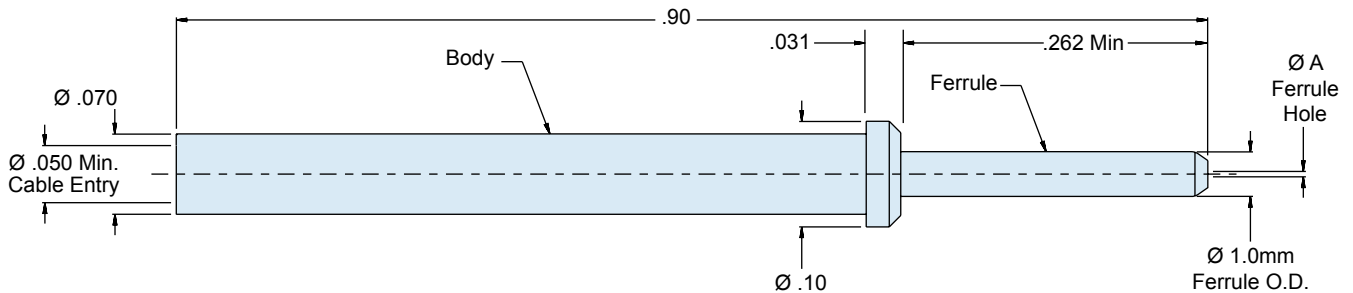

Material and Finish

Ferrule: Zirconia Ceramic
 Body: Stainless Steel/Passivate

Assembly Notes

Consult factory for appropriate termination and assembly tools/procedures.

D38999
 Series III

MIL-DTL-38999 Type Size 20 Socket Terminus

Part Number	Fiber Size Core/Cladding	Ø A (Microns)	Typ. Fiber Type
181-066-1255	9/125	125.5	Single Mode
181-066-126	50/125 & 62.5/125	126.0	Multi Mode

Terminus Accessories

Part Number	Terminus Accessory
181-066-S	Ceramic Alignment Sleeve
181-066-C	Protective Cover

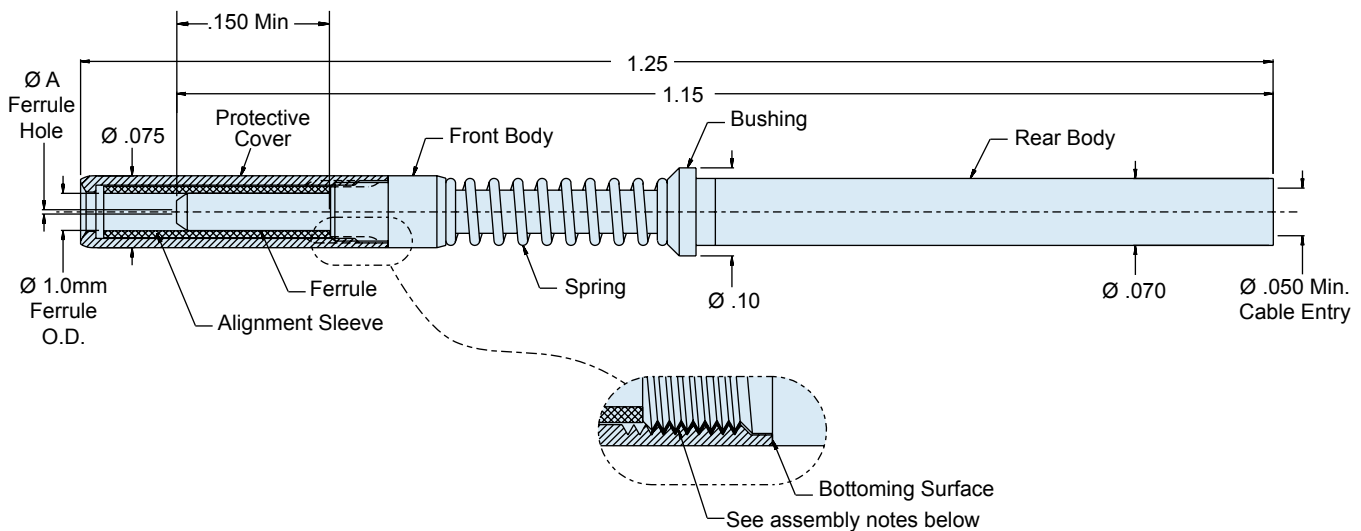
Material and Finish

Material / Finish:

Ferrule: Zirconia Ceramic

Alignment Sleeve: Zirconia Ceramic

Body (Front and Rear): Stainless Steel/Passivate

Protective Cover: Stainless Steel/Passivate

Bushing: Stainless Steel/Passivate

Spring: Stainless Steel/Passivate

Assembly Notes

Protective cover must be retained using Threadlocker "Loctite 222" prior to insertion and fully seated against terminus body as shown.

181-039
M29504/14
Size 16 MIL-PRF-28876 Type Fiber Optic Pin Terminus



Size 16 M29504/14 Fiber Optic Pin Terminus for MIL-PRF-28876 Connectors



Part Number	ØA (Microns)	Fiber Type	Fiber Size Core/Cladding (Microns)	Mil-Spec Part Number (Reference)
181-039-1250C	125.0	Single Mode	9/125	M29504/14-4140C
181-039-1255C	125.5	Single Mode	9/125	N/A
181-039-1260C	126.0	Single Mode	9/125	M29504/14-4141C
		Multi Mode	50/125, 62.5/125	M29504/14-4131C
181-039-1270C	127.0	Multi Mode	50/125, 62.5/125	M29504/14-4132C
181-039-1420C	142.0	Multi Mode	100/140	M29504/14-4135C
Consult factory for additional sizes				

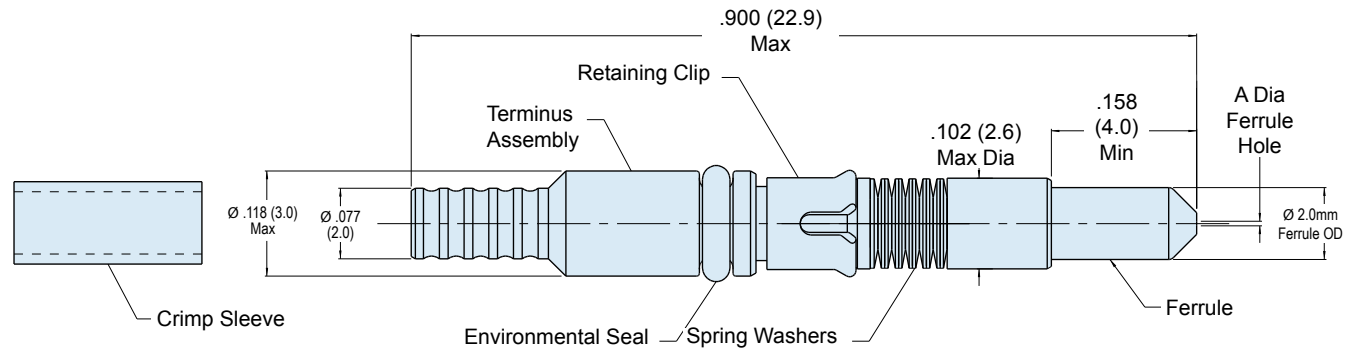

Tools and Accessories	
Part Number	Terminus Accessory
265-008	Crimp Sleeve Ø2.4mm Max Jacket (Mil-Spec Type)

Material and Finish

Ferrule: Zirconia Ceramic
 Terminus Assembly: Stainless Steel/ Passivate
 Retaining Clip, Spring Washers: Spring Alloy
 Seal: Fluorosilicone
 Crimp Sleeve: Brass Alloy/Nickel

Notes

Crimp sleeve is supplied with terminus assembly and may be ordered separately (see Table II). For terminus less crimp sleeve, omit **C** from end of part number.

Assembly

See Glenair GAP-036 for termination procedure and assembly tools.
 Dummy terminus part number: 181-051

M28876

**Size 16 M29504/15 Fiber Optic Socket Terminus
for MIL-PRF-28876 Connectors**

The use of fiber optics in shipboard and ship-to-shore data transmissions is growing rapidly, and the tight-tolerance MIL-PRF-28876 interconnect has become the universal standard for Navy shipboard applications. Glenair's qualified offering—including QPL'd MIL-PRF-29504/14 and /15 contacts—delivers all the necessary performance from precise optical alignment, to environmental protection, corrosion resistance and weight reduction. The Glenair MIL-PRF-28876 terminus is specifically geared for upgrade and retrofit applications where extending system life-cycles and reducing cost of ownership are principle requirements.

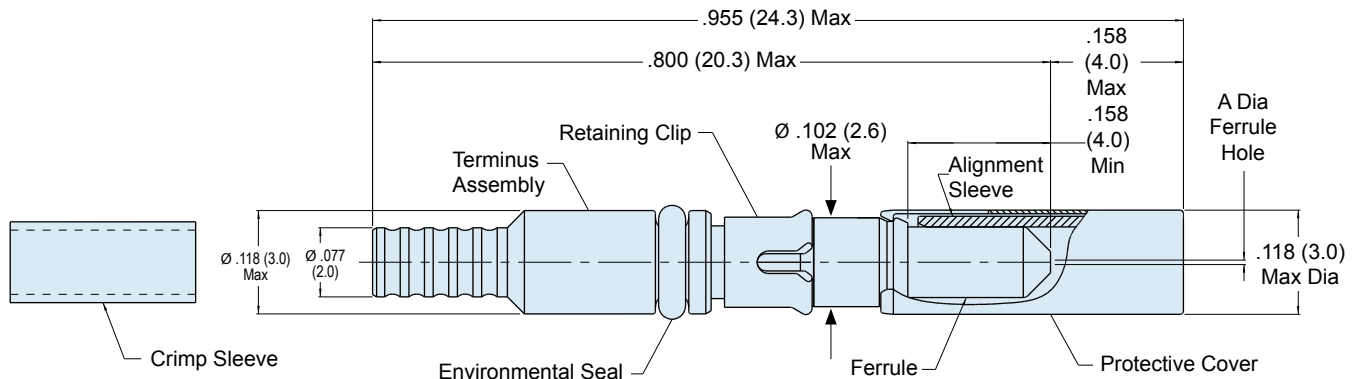
Material and Finish

Alignment Sleeve, Ferrule: Zirconia Ceramic
 Protective cover: Spring Alloy / Nickel
 Terminus Assembly: Stainless Steel / Passivate
 Retaining Clip: Spring Alloy
 Seal: Fluorosilicone
 Crimp Sleeve: Brass Alloy / Nickel

Tools and Accessories/Assembly Notes

Dummy Terminus: Part Number 181-051
 Crimp sleeve is supplied with terminus assembly and may be ordered separately (see Table II). For terminus less crimp sleeve omit **C** from end of part number.
 Alignment sleeve assembly is supplied with terminus assembly (packaged loose) and may be ordered separately (see Table II).
 See Glenair GAP-036 for termination procedure and assembly tools.

181-040
M29504/15
Size 16 Fiber Optic Socket Terminus
For MIL-PRF-28876 Connectors



Part Number	ØA (Microns)	Fiber Type	Fiber Size Core/Cladding (Microns)	Mil-Spec Part Number (Reference)
181-040-1250C	125.0	Single Mode	9/125	M29504/15-4180C
181-040-1255C	125.5	Single Mode	9/125	N/A
181-040-1260C	126.0	Single Mode	9/125	M29504/15-4181C
		Multi Mode	50/125, 62.5/125	M29504/15-4171C
181-040-1270C	127.0	Multi Mode	50/125, 62.5/125	M29504/15-4172C
181-040-1420C	142.0	Multi Mode	100/140	M29504/15-4175C
Consult factory for additional sizes				



Accessories	
Part Number	Terminus Accessory
265-010	Alignment Sleeve Assembly
265-008	Crimp Sleeve Ø2.4mm Max Jacket (Mil-Spec type)

Mighty
Mouse

Size 16 Fiber Optic Pin Terminus for Series 80 Mighty Mouse Connectors



Part Number	ØA (Microns)	Fiber Size: Core/ Cladding (Microns)	Typ. Fiber Type
181-057-125	125.5	9/125 (Single Mode)	Single Mode
181-057-126	126.0	50/125 and 62.5/125	Multi Mode

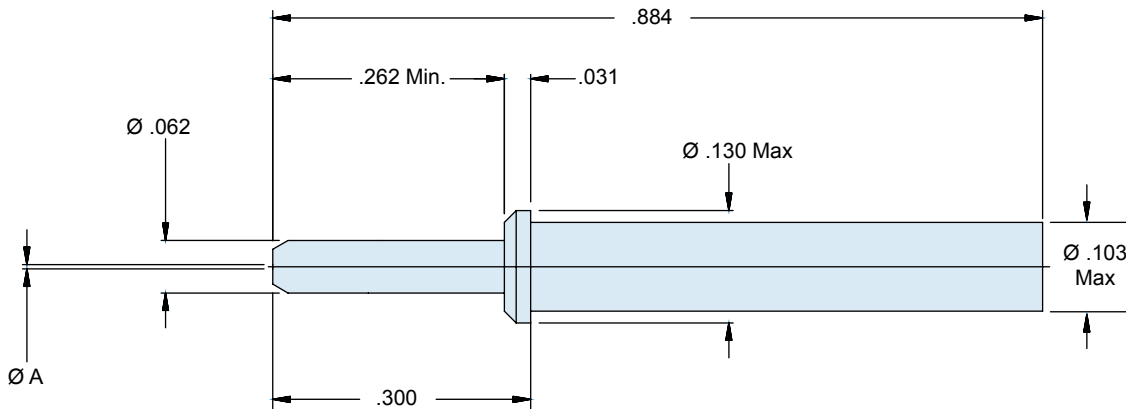

Material and Finish

Ferrule: Zirconia Ceramic

Terminus Assembly: Stainless Steel / Passivate

Assembly Notes

See Glenair GAP-039 for termination procedure and assembly tools.

Recommended insertion/extraction tool: P/N M81969/14-03

181-075
Size 16 Fiber Optic Socket Terminus
For Series 80 Mighty Mouse



Size 16 Fiber Optic Socket Terminus for Series 80 Mighty Mouse Connectors



Part Number	ØA (Microns)	Fiber Size: Core/Cladding (Microns)	Typ. Fiber Type
181-075-125	125.5	9/125	Single Mode
181-075-126	126.0	50/125, 62.5/125	Multi Mode

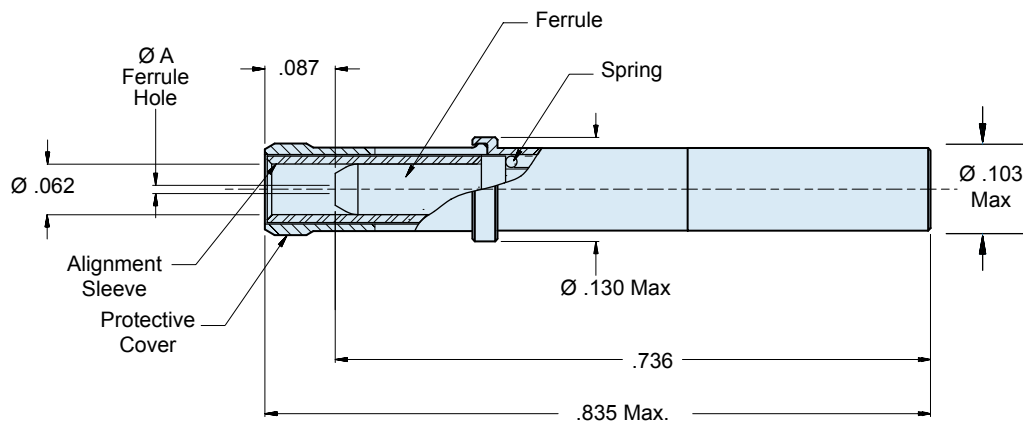

Accessories	
Part Number	Terminus Accessory
181-001-S	Ceramic Alignment Sleeve
181-075-C	Protective Cover

Material and Finish

Ferrule: Zirconia Ceramic
 Terminus Assembly: Stainless Steel / Passivate
 Spring: Stainless Steel / Passivate
 Protective Cover: Spring Alloy / Nickel

Assembly Notes

See Glenair GAP-039 for termination procedure and assembly tools.
 Recommended insertion/extraction tool: P/N M81969/14-03
 Ceramic alignment sleeve and protective cover are supplied with terminus assembly and may be ordered separately (See Table II).

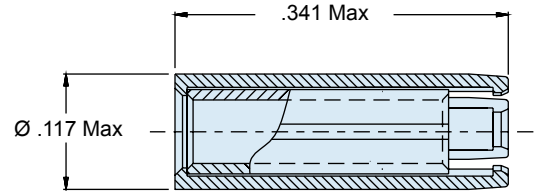
Size 16 COTS Front Release Fiber Optic Socket Terminus

Protective cover with captive alignment sleeve

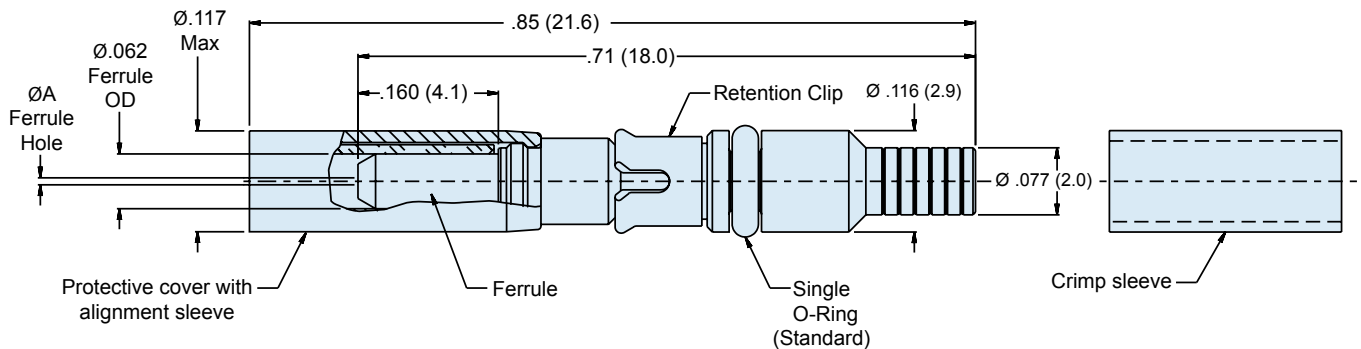
Material and Finish

Ferrule, Alignment Sleeve: Zirconia Ceramic
 Protective Cover: Spring Alloy
 Terminus Assembly: Stainless Steel/Passivate
 Retention Clip: Spring Alloy
 O-Ring: Fluorosilicone
 Crimp Sleeve: Brass Alloy/Nickel

Tools and Accessories/Assembly Notes

See Glenair GAP-031 and GAP-031B for complete assembly instructions.
 Alignment sleeve assembly (protective cover and alignment sleeve) and crimp sleeve are supplied with assembly. Spares may be ordered separately (See Table II).
 See 181-051 for dummy terminus.

181-011
COTS Fiber Optic Socket Terminus
Size 16 Front Release



Part Number	Fiber Size: Core/Cladding/Coating (Microns)	Ø A (Microns)
181-011-125	9/125 (Single Mode)	125.5
181-011-126S	9/125 (Single Mode)	126.0
181-011-126	50/125, 62.5/125	126.0
181-011-142	100/140	142.0
181-011-156	62.5/125/155 (Polyimide)	156.0
181-011-173	100/140/172 (Polyimide)	173.0
181-011-175	100/140/172 (Polyimide)	175.0
181-011-231	200/225	231.0
181-011-236	200/230	236.0
181-011-286	200/280	286.0
181-011-448	400/440	448.0

Ceramic alignment sleeve supplied with terminus. Add **K** to the end of part number development to supply with optional stainless steel alignment sleeve e.g. 181-011-126**K**.

For dual O-ring design, add **D** to end of part number development (e.g. 181-011-126**KD**)



Accessories	
Part No.	Terminus Accessories
181-011-S	Protective Cover with Ceramic Alignment Sleeve
181-011-K	Protective Cover with Stainless Steel Alignment Sleeve
265-002	Crimp Sleeve, Ø2.2mm Max Jacket

Size 16 COTS Front Release Fiber Optic Pin Terminus

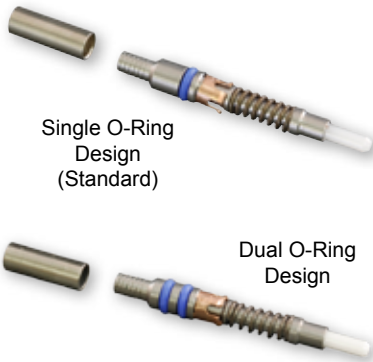

The unique design of the Glenair 181-011 and 181-012 series fiber optic contact allows for rapid integration of optical media in a broad range of cylindrical and rectangular connector packages and systems. By placing the retention and environmental sealing components directly on the termini, Glenair is able to fabricate unique fiber optic connector shell packages without costly tooling and engineering. The secret is the integrated retention clip and environmental O-ring located directly on the contact. Glenair's in-house expertise and capacity for machining connector shells to the precise tolerances required in optical connection systems is the other half of the story. Finished connector systems perform at insertion-loss levels equivalent to other high-performance, tactical fiber optic systems such as MIL-DTL-38999 and MIL-PRF-28876.

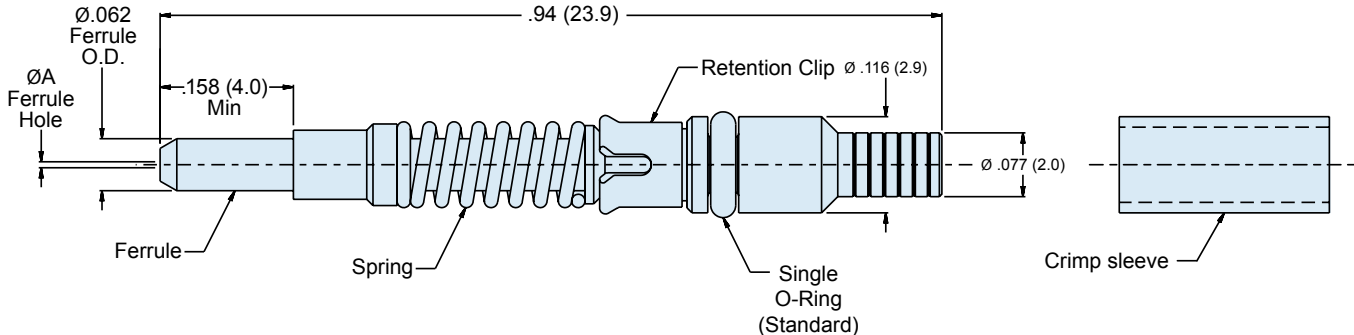

Material and Finish

Ferrule: Zirconia Ceramic

Terminus Assembly: Stainless Steel/Passivate

Spring: Stainless Steel/Passivate

Retention Clip: Spring Alloy

O-Ring: Fluorosilicone

Crimp Sleeve: Brass Alloy/Nickel

Tools and Accessories/Assembly Notes

Crimp sleeve supplied with assembly. Spares may be ordered separately (see Table II).

See Glenair GAP-031 and GAP-031B for complete assembly instructions.

See 181-051 for dummy terminus.

181-012
COTS Fiber Optic Pin Terminus
Size 16 Front Release



Part Number	Fiber Size Core/Cladding/Coating (Microns)	Ø A (Microns)
181-012-125	9/125 (Single Mode)	125.5
181-012-126S	9/125 (Single Mode)	126.0
181-012-126	50/125, 62.5/125	126.0
181-012-142	100/140	142.0
181-012-156	62.5/125/155 (Polyimide)	156.0
181-012-173	100/140/172 (Polyimide)	173.0
181-012-175	100/140/172 (Polyimide)	175.0
181-012-231	200/225	231.0
181-012-236	200/230	236.0
181-012-286	200/280	286.0
181-012-448	400/440	448.0
For dual O-ring design, add D to end of part number development (e.g. 181-012-126 D)		



Terminus Tools and Accessories	
Part No.	Terminus Accessories
265-002	Crimp Sleeve, Ø 2.2mm Max Jacket

Genderless Fiber Optic Terminus for ARINC 801 Connectors, Keyed, Rear Release

Part Number	ØA (Microns)	Typ. Fiber Type	Pull-Proof
181-076-N-1255	125.5	Single Mode	no
181-076-N-1265	126.0	Single Mode	no
181-076-N-126	126.0	Multi Mode	no
181-076-P-1255	125.5	Single Mode	yes
181-076-P-1265	126.0	Single Mode	yes
181-076-P-126	126.0	Multi Mode	yes

Consult factory for additional sizes.

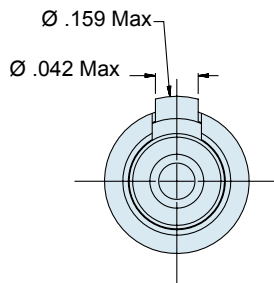
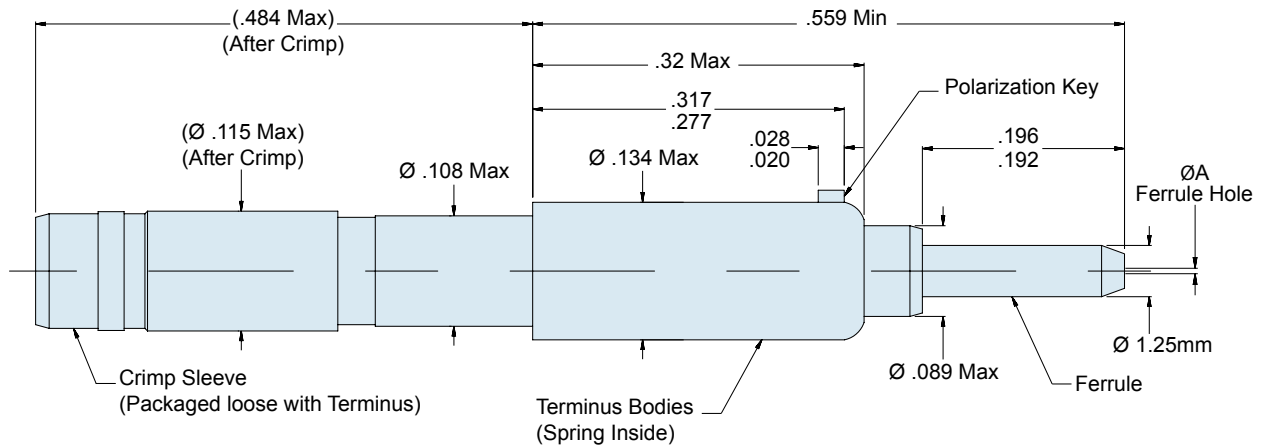
Material and Finish

Ferrule: Zirconia Ceramic
 Terminus Bodies: Brass Alloy/Nickel
 Crimp Sleeve: Brass Alloy/Nickel
 Spring: Stainless Steel/Passivate

Specifications

Terminus Accommodates cable diameter 1.73mm (.068) minimum and 2.00mm (.079) maximum.
 Pull-proof termini are for use with loose structure cable.

187-079

Size 16 M29504/6 Type Pin Terminus
For ARINC 600 and 404 Connectors



Size 16 Fiber Optic M29504/6 Type Pin Terminus



Part Number	Fiber Size Core/Cladding/Coating (Microns)	ØA (Microns)
187-079-125	9/125 (Single Mode)	125.5
187-079-126	50/125 & 62.5/125	126.0
187-079-142	100/140	142.0
187-079-156	62.5/125/155 (Polyimide)	156.0
187-079-175	100/140/172 (Polyimide)	175.0
187-079-231	200/230	231.0
187-079-236	200/233	236.0
187-079-286	200/280	286.0
187-079-448	400/440	448.0

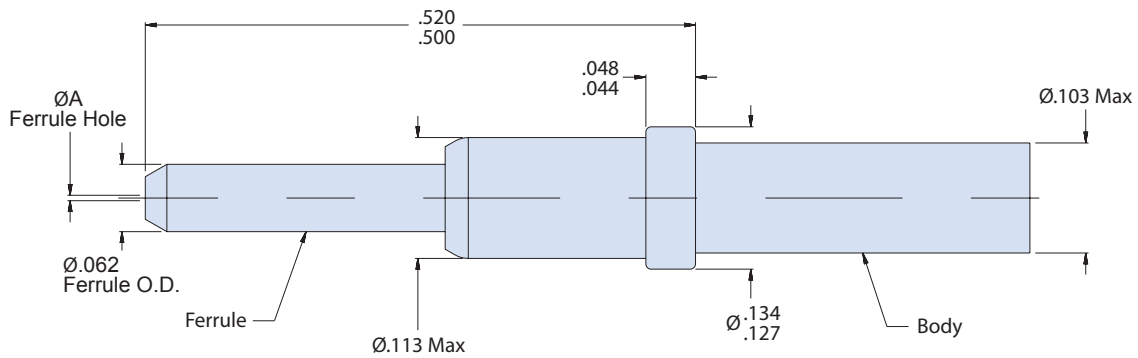

Material and Finish

Ferrule: Zirconia Ceramic
Body: Stainless Steel/Passivate

Specifications

Terminus is also designed for use with Glenair 187-100 Combo D-Sub Receptacle connector.

Size 16 Fiber Optic M29504/7 Type Socket Terminus



The precision design of the Glenair 187-080 and 187-079 series fiber optic contacts for ARINC type connectors enables reliable and repeatable integration of optical media into industry-standard ARINC connector systems. The Glenair M29504/7 Type socket terminus and M29504/6 Type pin terminus provide low dB loss performance. The precision ceramic ferrule and alignment sleeve ensure precise optical alignment of fiber media. Available for singlemode and multimode glass fiber as well as 155.0 and 172.0 micron polyimide media.

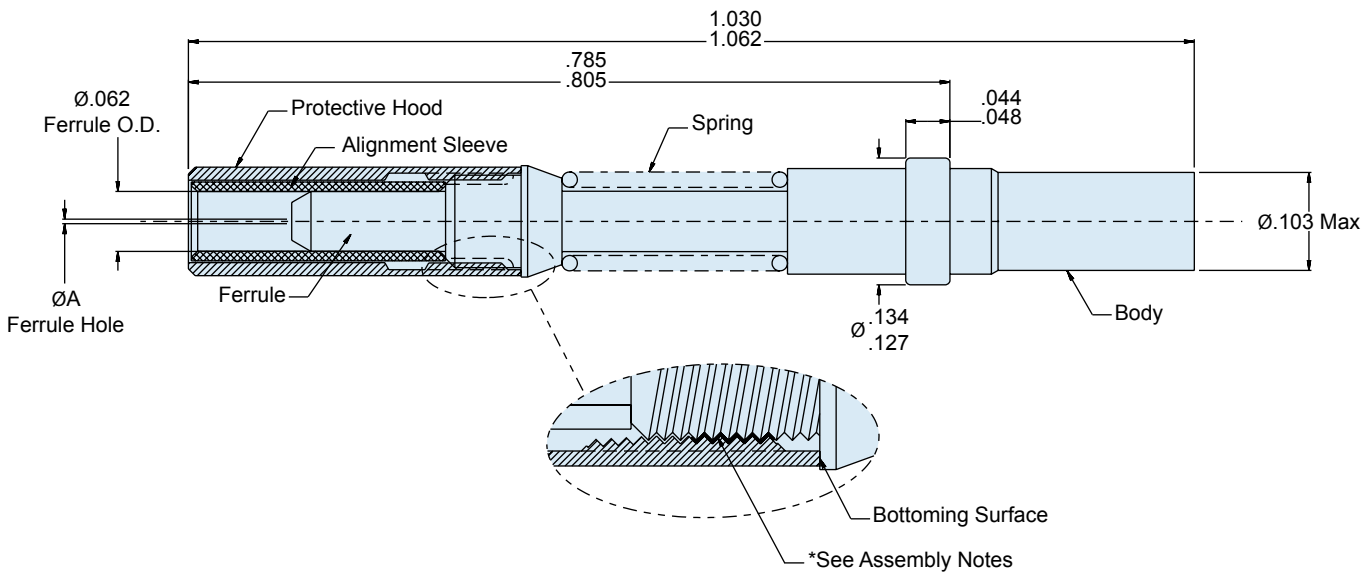

Material and Finish

Ferrule, Alignment Sleeve: Zirconia Ceramic
 Body, Spring and Protective Hood: Stainless Steel/Passivate

Tools and Accessories/Assembly Notes

Alignment Sleeve and Protective Cover can also be ordered separately (Table II)
 *Threaded Protective cover must be retained using Threadlocker "Loctite 222" prior to insertion and fully seated against terminus body as shown.

187-080
Size 16 M29504/7 Type Socket Terminus
For ARINC 600 and 404 Connectors



Part Number	Fiber Size Core/Cladding/Coating (Microns)	ØA (Microns)
187-080-125	9/125 (Single Mode)	125.5
187-080-126	50/125 & 62.5/125	126.0
187-080-142	100/140	142.0
187-080-156	62.5/125/155 (Polyimide)	156.0
187-080-175	100/140/172 (Polyimide)	175.0
187-080-231	200/230	231.0
187-080-236	200/233	236.0
187-080-286	200/280	286.0
187-080-448	400/440	448.0

Terminus Accessories	
Part Number	Terminus Accessory
181-001-S	Ceramic Alignment Sleeve
181-001-C	Protective Cover



Size 18 Non-Keyed Front Release Glenair High Density (GHD) Genderless Terminus

The Glenair High Density Fiber Optic Connector System is designed for applications that require reduced size and weight as well as outstanding optical and environmental performance. The System offers insertion loss values less than .5dB (typical loss for Glenair terminus is .3 dB). Dense cavity spacing is achieved with an innovative front release terminus design and accommodation for M85045/16 cable. The genderless 18 gauge GHD contact delivers nearly double the density of M28876 and D38999 with superior optical performance.

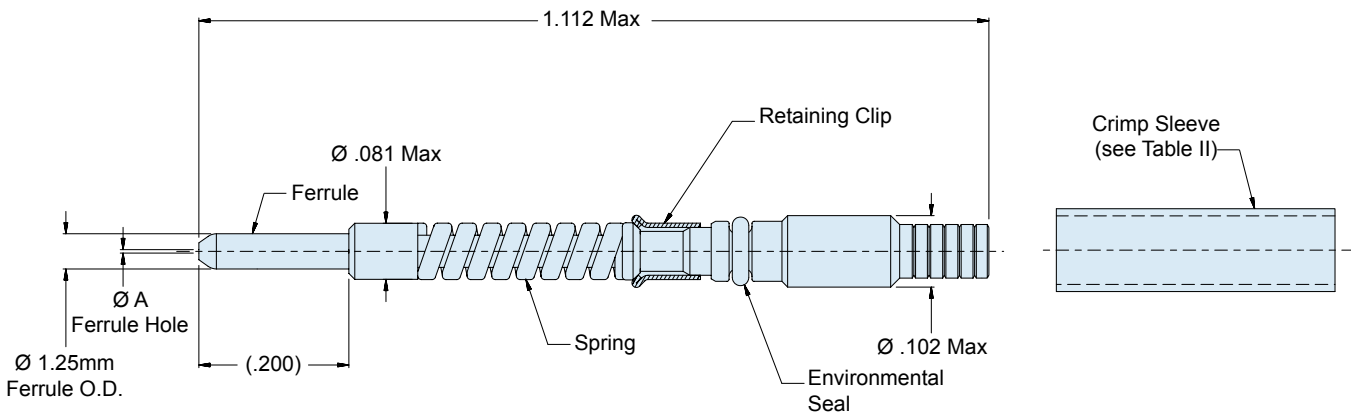
Material and Finish

Ferrule: Zirconia Ceramic
Terminus Assembly: Stainless Steel/Passivate
Retaining Clip: Spring Alloy
Spring: Stainless Steel/Passivate
Seal: Fluorosilicone
Crimp Sleeve: Brass Alloy/Nickel

Tools and Accessories/Assembly Notes

Crimp Sleeve is supplied with Terminus Assembly, and may be ordered separately (see Table II).
For terminus less crimp sleeve, omit **C** from end of part number (e.g. **181-056-1260**)
See Glenair assembly procedure GAP-032 for complete termination instructions.

181-056
GHD • Glenair High Density
Fiber Optic Genderless Terminus
Size 18 Non-Keyed Terminus



Part Number	ØA (Microns)	Typ. Fiber Type
181-056-1250C	125.0	Single Mode
181-056-1255C	125.5	Single Mode
181-056-1260C	126.0	Single Mode OR Multi Mode
181-056-1270C	127.0	Multi Mode
181-056-1420C	142.0	Multi Mode
181-056-1450C	145.0	Multi Mode
181-056-1560C	156.0	Multi Mode
181-056-1570C	157.0	Multi Mode
181-056-1730C	173.0	Multi Mode
181-056-1750C	175.0	Multi Mode
181-056-2360C	236.0	Multi Mode
181-056-2860C	286.0	Multi Mode
181-056-4480C	448.0	Multi Mode

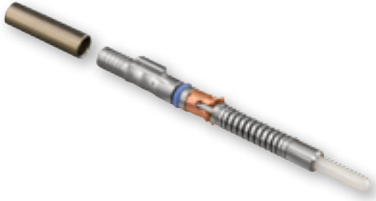

CRIMP SLEEVE	
Part Number	Description
265-002	Crimp Sleeve Ø2.2mm Max Jacket

**Size 18 Glenair High Density (GHD) Fiber Optic Genderless Terminus,
Keyed for APC Polish**

The Glenair High Density Fiber Optic Connector System is designed for applications that require reduced size and weight as well as outstanding optical and environmental performance. The System offers insertion loss values less than .5dB (typical loss for Glenair termini is .3 dB). Dense cavity spacing is achieved with an innovative front release terminus design and accommodation for M85045/16 cable. The 181-047 version is equipped with a single keying feature for APC polish.

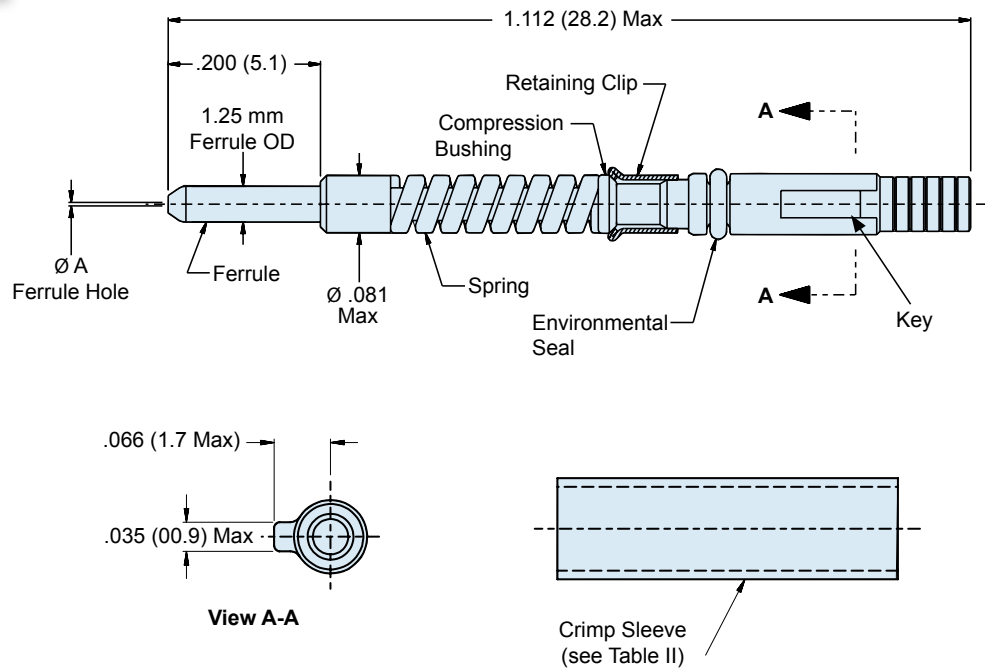
Material and Finish

Ferrule: Zirconia Ceramic
Terminus Assembly: Stainless Steel/ Passivate
Retaining Clip: Spring Alloy
Spring: High Tensile Stainless Steel/ Passivate
O-Ring: Fluorosilicone
Crimp Sleeve: Brass Alloy/Nickel

Tools and Accessories

Crimp Sleeve is supplied with Terminus Assembly, and may be ordered separately (see Table II). For terminus less crimp sleeve, omit **C** from end of part number (e.g. **181-047-1260**) See Glenair assembly procedure GAP-032 for complete termination instructions.

181-047
GHD • Glenair High Density
Fiber Optic Genderless Terminus
Size 18 Keyed Terminus for APC Polish



Part Number	ØA (Microns)	Typ. Fiber Type
181-047-1250C	125.0	Single Mode
181-047-1255C	125.5	Single Mode
181-047-1260C	126.0	Single Mode OR Multi Mode
181-047-1270C	127.0	Multi Mode
181-047-1420C	142.0	Multi Mode
181-047-1450C	145.0	Multi Mode
181-047-1560C	156.0	Multi Mode
181-047-1570C	157.0	Multi Mode
181-047-1730C	173.0	Multi Mode
181-047-1750C	175.0	Multi Mode
181-047-2360C	236.0	Multi Mode
181-047-2860C	286.0	Multi Mode
181-047-4480C	448.0	Multi Mode



CRIMP SLEEVE	
Part Number	Description
265-002	Crimp Sleeve Ø2.2mm Max Jacket

Glenair High Density (GHD) Size 18 Fiber Optic Dummy Terminus

Description	Part Number
Dummy Terminus, size 18	181-058

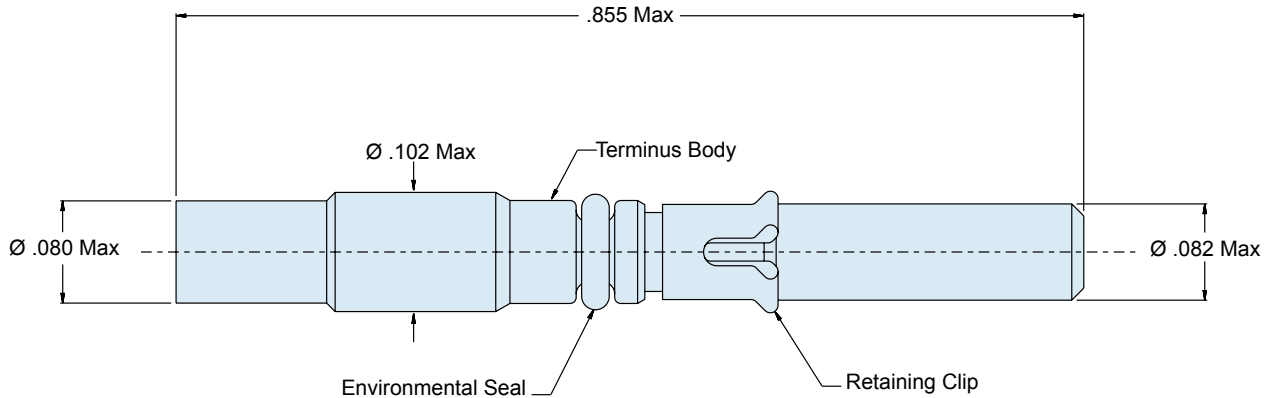
Material and Finish

Terminus Body: Stainless Steel/Passivate
 Retaining Clip: Spring Alloy
 Environmental Seal: Fluorosilicone

181-051
M29504/3-4038
MIL-PRF-28876 Type Size 16 Dummy Terminus



M28876

MIL-PRF-28876 Size 16 Dummy Terminus



Description	Part Number
Dummy Terminus, size 16	181-051

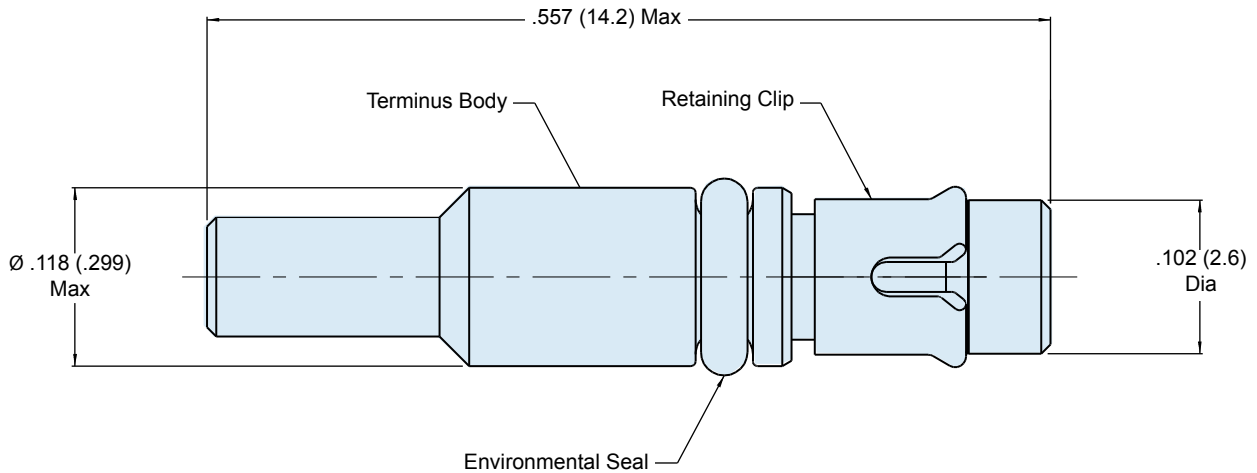

Material and Finish

Terminus Body: Stainless Steel/Passivate
Retaining Clip: Spring Alloy/Nickel
Seal: Fluorosilicone

Tools and Accessories/Assembly Notes

See Glenair GAP-036 for assembly tools and procedures.

GFOCA

M29504/16 Type Genderless GFOCA Fiber Optic Terminus



Most commonly used by the army for long-run battlefield communications, the GFOCA Connection System is also well suited to dockside naval communications, down-hole drilling and other harsh environment applications. The hermaphroditic system utilizes low insertion loss butt-joint termini and a ruggedized coupling mechanism for reliable, repeatable mating. The genderless mating system is rated to 1000-2000 cycles depending on fiber media selection.

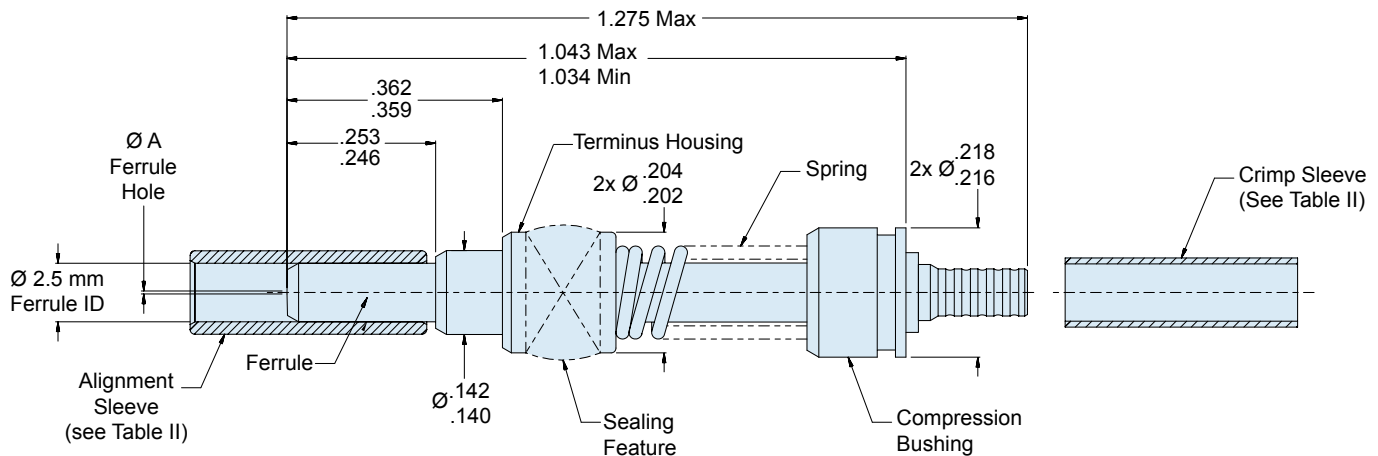

Material and Finish

Ferrule: Ceramic
Terminus Housing: Stainless Steel/Passivate
Spring: Stainless Steel/Passivate
Compression Bushing: Stainless Steel/Passivate
Crimp Sleeve: Brass Alloy/Nickel
Seal(s): Elastomeric Rubber

Specifications

Terminus is designed to meet the general requirements of MIL-PRF-29504/16
Terminus is intended for use with the following connectors:
180-116: Plug, Hermaphroditic
180-117: Recp, Jam Nut Mount
180-125: Recp, Flange Mount

Tools and Accessories/Assembly Notes

Alignment Sleeve (not supplied with Terminus) may be ordered separately (see table II)
Crimp sleeve is supplied with terminus assembly, and may be ordered separately. For terminus less crimp sleeve, omit **C** from end of part number (e.g. **181-050-1260**)

181-050
M29504/16 Type
Genderless GFOCA Fiber Optic Terminus



Part Number	ØA (Microns)	Fiber Type (Typical)
181-050-1250C	125.0	Single Mode
181-050-1255C	125.5	Single Mode
181-050-1260C	126.0	Single Mode AND Multi Mode
181-050-1270C	127.0	Multi Mode
181-050-1420C	142.0	Multi Mode
181-050-2300C	230.0	Multi Mode

Accessories	
Part Number	Terminus Accessory
181-050-S	Split Ceramic Alignment Sleeve
265-008	Crimp Sleeve, Ø2.4mm Max Cable Jacket



GFOCA

GFOCA Fiber Optic Dummy Terminus

Description	Part Number
GFOCA Dummy Terminus	181-059

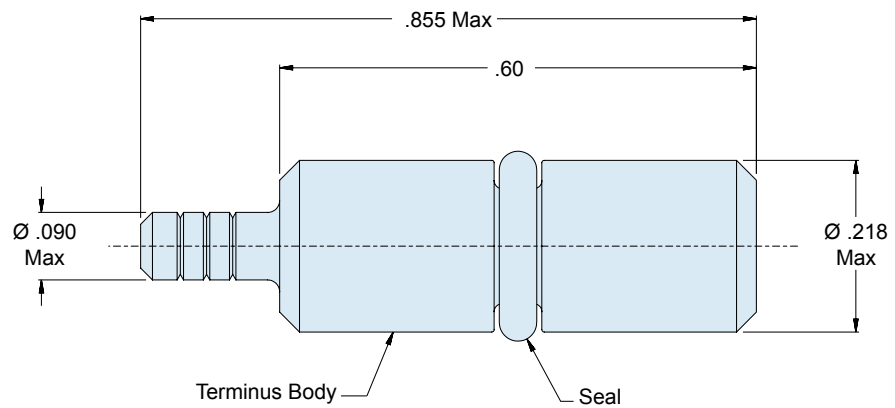
Material and Finish

Terminus Body: Stainless Steel/Passivate
 Seal: Elastomer

Specifications

Terminus is intended for use with the following connectors:

- 180-116: Plug, Hermaphroditic
- 180-117: Receptacle, Jam Nut Mount
- 180-125: Receptacle, Flange Mount

181-043
MIL-PRF-29504/18 Type
NGCON Fiber Optic Terminus



M29504/18 (NGCON) Genderless Rear Release Pin with Integrated Retention Clip



Part Number	ØA (Microns)	Fiber Type (Typical)		Mil-Spec Style M29504/18-XXX (Reference)
		Typical Fiber Type	Size Core/Cladding/Coating (Microns)	
181-043-1250C	125.0	SM	9/125	-101, -201, -204
181-043-1255C	125.5	SM	9/125	-102, -202, -205
181-043-1265C	126.0	SM	9/125	-103, -203, -206
181-043-126C	126.0	MM	50/125, 62.5/125	-126, -226
181-043-127C	127.0	MM	50/125, 62.5/125	-127, -227
181-043-142C	142.0	MM	100/140	-242
181-043-145C	145.0	MM	100/140	-245
181-043-156C	156.0	MM	62.5/125/155	-256
181-043-157C	157.0	MM	62.5/125/155	-257
181-043-173C	173.0	MM	100/140/172	-273
181-043-175C	175.0	MM	100/140/172	-275

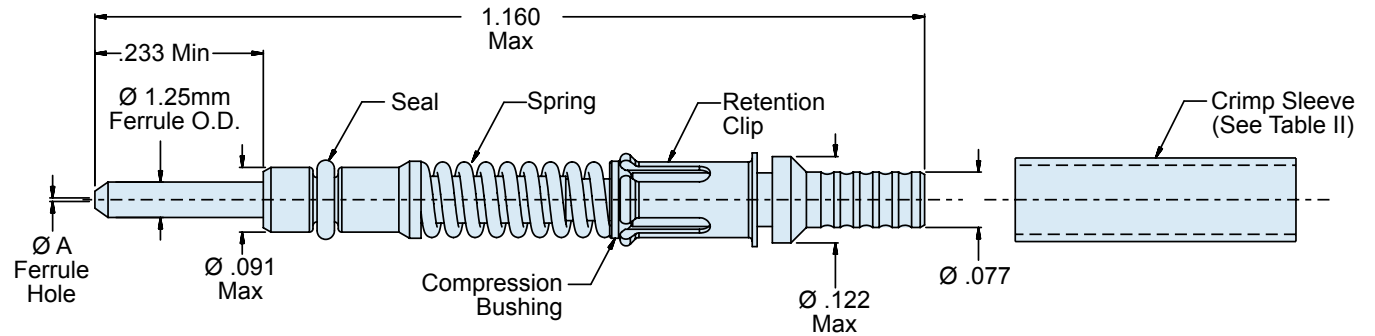

Crimp Sleeve	
Part No.	Description
265-008	Crimp Sleeve, Ø2.4mm Max Jacket (MIL-SPEC Type)

Material and Finish

Ferrule: Zirconia Ceramic
 Terminus Assembly: Stainless Steel/Passivate
 Retention Clip: Spring Alloy
 Spring: Stainless Steel/Passivate
 Seal: Elastomeric Rubber
 Crimp Sleeve: Brass Alloy/Nickel

Accessories

See Glenair GAP-044 for termination assembly instructions and appropriate tools.
 Crimp sleeve is supplied with terminus assembly and may be ordered separately (see Table II).
 For terminus less crimp sleeve, omit C from part number (e.g. **181-043-126**)

SERIES 80

MIGHTY MOUSE

- ◆ **Up To 71% Weight Savings and 52% Size Savings Compared to MIL-DTL-38999**
- ◆ **The World's Best Availability—Thousands of Part Numbers In Stock and Ready for Immediate Same-Day Shipment**



Series 801
Mighty Mouse
7 Contacts



MIL-DTL-38999
6 Contacts



Special Purpose

High Performance Contacts: Thermocouple, Pneumatic, PC Tail, High Power, Solder Cup and More

A Solution for Every Challenge

Glenair produces a wide range of special purpose contacts including high power and high ampacity contacts, pneumatic contacts, PC Tail contacts for board terminations and thermocouple contacts for use in temperature measuring applications. We also produce all the small accessory items, such as sealing plugs, that make us a convenient one-stop-shopping destination for users of high-performance Mil-Spec and commercial connectors and contacts.

We invite our customers to take advantage of the breadth and depth of our contact product line, especially its high-availability and our willingness to engineer unique and special-purpose contact solutions for virtually any interconnect challenge.

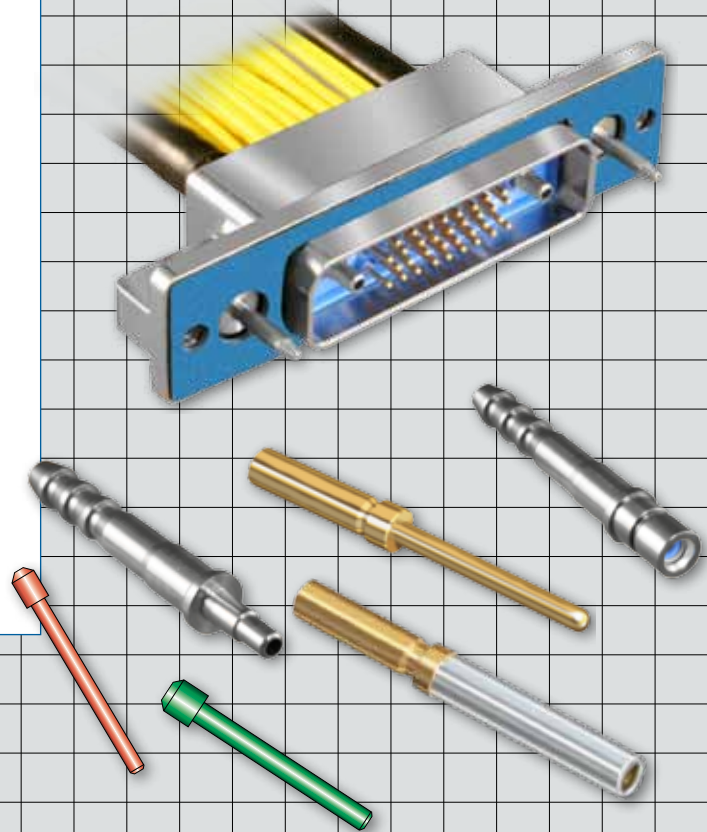

D

- ◆ SAE-AS39029 QPL'd and Commercial Contacts
- ◆ Same Day Inventory on Popular and Hard-to-Find Styles
- ◆ Highest Quality Materials Including Enhanced Durability Plating
- ◆ Unique and Hard-to-Find Contacts



Special Purpose Contacts Selection Guide

Glenair Part Number	Part Description	Contact Size	Type	Product Page
859-012	Grommet Sealing Plugs (MS27488 Type)	0-23	Sealing Plug	D-3
809-001	Series 80 Mighty Mouse Pin Contact	23	Crimp Contact	D-4
809-002	Series 80 Mighty Mouse Socket Contact	23	Crimp Contact	D-5
830-004	Pneumatic Socket Contact for Series 79, Series 80 and D38999 Series II	12	Pneumatic	D-6
830-005	Pneumatic Socket Contact for Series 79, Series 80 and D38999 Series I, III, IV	12	Pneumatic	D-6
830-003	Pneumatic Pin Contact for Series 79, Series 80 and D38999 Series I, II, III, IV	12	Pneumatic	D-7
850-010	PCB Pin Contact to fit D38999/20 and /24	12-22	PCB Pin	D-8
850-011	PCB Socket Contact to fit D38999/20 and /24	12-22	PCB Socket	D-9
850-013	High Power Socket Contact	8	Power Socket	D-10
850-014	High Power Pin Contact	8	Power Pin	D-11
850-015	M39029/56 Type Socket Contact with Solder Cup	10-22	Solder Cup	D-12
850-016	Pin Contact with Solder Cup	10-22	Solder Cup	D-14
850-017	M39029/58 Type Pin Contact with Solder Cup	12-22	Solder Cup	D-16
850-018	M39029/56-348 Type Socket Contact	22	Crimp Contact	D-18
850-019	M39029/58-360 Type Pin Contact	22	Crimp Contact	D-19
850-020	M39029/57 Type Socket Contact	22	Crimp Contact	D-20
857-027	M39029/58 Type High Power Pin with PC Tails	8	PCB Power	D-21
857-028	M39029/56 Type High Power Socket with PC Tails	8	PCB Power	D-22
687-348	Wire to Contact Crimp Adapter	4-22	Crimp Adapter	D-23
850-023	M39029/87 Thermocouple Pin Contact	16-22	Thermocouple	D-24
850-024	M39029/88 Thermocouple Socket Contact; Series I, II, IV	16-22	Thermocouple	D-26
850-025	M39029/89 Thermocouple Socket Contact; Series II	16-22	Thermocouple	D-28

Grommet Sealing Plugs

MS27488 Type

Size 0 Through 23



Special Purpose

Grommet Sealing Plugs

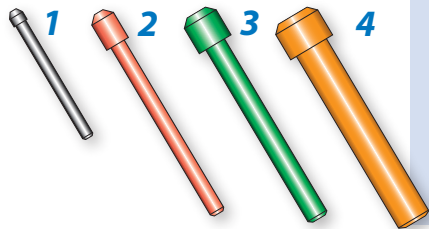

Grommet sealing plugs are used to seal unwired contact cavities. The size #23 sealing plug is specially designed to fit Glenair Series 80 Mighty Mouse grommets. Sizes 20 through 0 plugs conform to MS27488 requirements. After installing unwired contacts into unused cavities, insert knob end of sealing plug into grommet until it bottoms against the unwired contact per illustration. Install sealing plugs with standard contact insertion/extraction tools. Size #23 plug is polyphenylsulfone, other sizes are per MS27488 requirements.

Fig.	Size	Color	Part Number	Military Part Number	Insertion/Extraction Tool	A Ref.		B Ref.		C Ref.		D Ref.	
						in.	mm.	in.	mm.	in.	mm.	in.	mm.
1	#23	Black	809-155	(None)	M81969/14-01	.040	1.02	.51	13.0	.052	1.32	.050	1.27
2	#20	Red	859-012	MS27488-20-2	M81969/14-11	.053	1.35	.81	20.8	.085	2.16	.125	3.18
3	#16	Green	859-013	MS27488-16-2	M81969/14-03	.074	1.88	.87	22.1	.125	3.18	.125	3.18
4	#12	Orange	859-014	MS27488-12-2	M81969/14-04	.120	3.05	.84	21.3	.165	4.19	.125	3.18
N/A	#8	Red		MS27488-8-3	Not Recommended	.170	4.32	1.19	30.2	.310	7.87	.125	3.18
N/A	#4	Blue		MS27488-4-3	Not Recommended	.278	7.06	1.19	30.2	.409	10.39	.125	3.18
N/A	#0	Yellow		MS27488-0-3	Not Recommended	.423	10.74	1.07	27.2	.601	15.27	.125	3.18

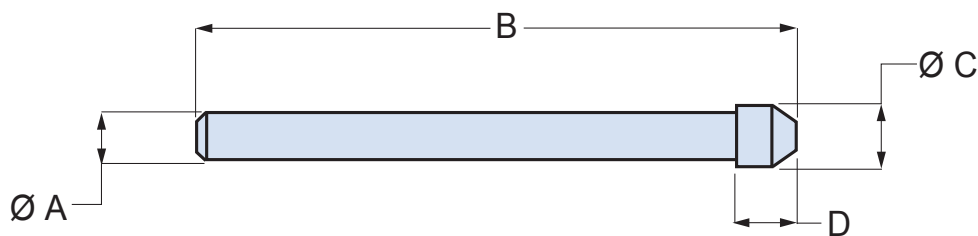

D



Installation of Sealing Plugs

"It is recommended to install unwired contacts in unused holes. Insert sealing plug behind each unwired contact. Push sealing plug (large end first) until seated."

(NAVAIR 01-1A-505-1 Installation manual)

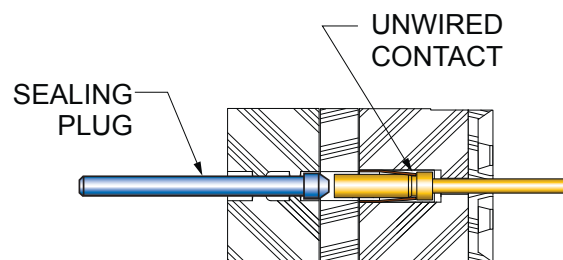



809-001
#23 Electrical Pin Contact
 For Series 79 Micro-Crimp and Series 80 Mighty Mouse

Size #23 Crimp Pin Contact for Micro-Crimp and Mighty Mouse Connectors



Contact Type	Wire Size	Material	Part Number	Ø A		Color Band
				In.	mm.	
Pin	#22 – #28	BeCu	809-001	.0335-.0355	0.851-0.902	None
Pin	#26 – #30	BeCu	809-042	.0229-.0245	0.582-0.622	Blue
Pin	#22 – #28	Alumel	809-065A	.0335-.0355	0.851-0.902	None
Pin	#22 – #28	Chromel	809-065C	.0335-.0355	0.851-0.902	None

Standard size #23 contacts accept #22 to #28 AWG wire. Choose "small bore" versions for #26 to #30 AWG wire. For thermocouple applications, specify alumel or chromel contacts. Contacts are bulk packaged. Terminate with standard M22520 crimper with special positioner.

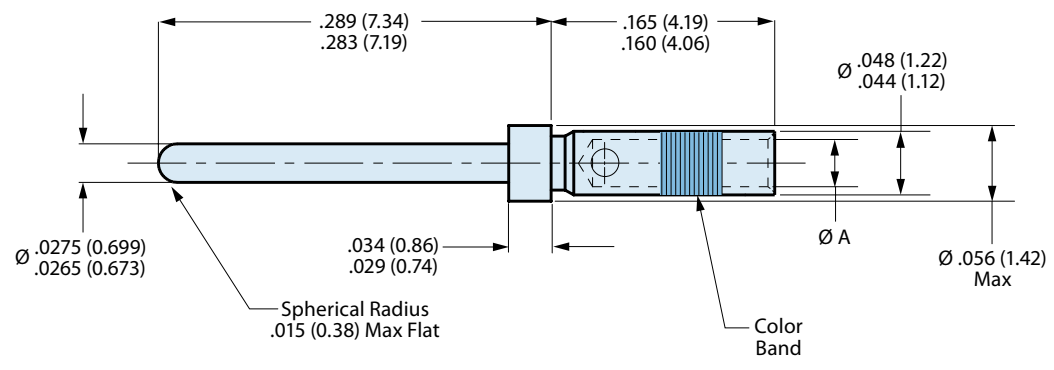

D

CRIMP TENSILE STRENGTH		
Values are in pounds and are minimums.		
Wire Gage	Silver or Tin Coated Copper Wire	Nickel Coated Copper Wire
#22	12	8
#24	8	6
#26	5	3
#28	3	2
#30	1.5	1.5

Material and Finish
 Beryllium copper alloy per ASTM B196 or B197, 50 microinches gold plated per ASTM B488 Type 3 Code C Class 1,27 over nickel plate per QQ-N-290 Class 2, 50-100 microinches.
 Thermocouple contacts: alumel or chromel alloy, unplated, per ANSI 96.1
 Socket contact hood: stainless steel, passivated per AMS-QQ-P-35.

Specifications
 Current Rating: 5 Amps maximum
 Voltage Drop (at 5 Amps and 25° C): 70 millivolts maximum
 Temperature Range: -65° to + 200° C
 Socket Contact Minimum Separation Force: 0.5 ounces

Crimp Tools and Insertion/Extraction Tools
 Crimper: 809-015 or AFM8
 Positioner: 809-005 (std). Use P/N 809-057 for small bore contacts 809-065 and 809-066
 Standard Insertion/Extraction Tool: 809-088

809-002

#23 Electrical Socket Contact
For Series 79 Micro-Crimp and Series 80 Mighty Mouse



Special Purpose

Size #23 Crimp Socket Contact for Micro-Crimp and Mighty Mouse Connectors



Contact Type	Wire Size	Material	Part Number	Ø A		Color Band
				In.	mm.	
Socket	#22 – #28	BeCu	809-002	.0335-.0355	0.851-0.902	None
Socket	#26 – #30	BeCu	809-043	.0229-.0245	0.582-0.622	Blue
Socket	#22 – #28	Alumel	809-066A	.0335-.0355	0.851-0.902	None
Socket	#22 – #28	Chromel	809-066C	.0335-.0355	0.851-0.902	None

Standard size #23 contacts accept #22 to #28 AWG wire. Choose "small bore" versions for #26 to #30 AWG wire. For thermocouple applications, specify alumel or chromel contacts. Contacts are bulk packaged. Terminate with standard M22520 crimper with special positioner.

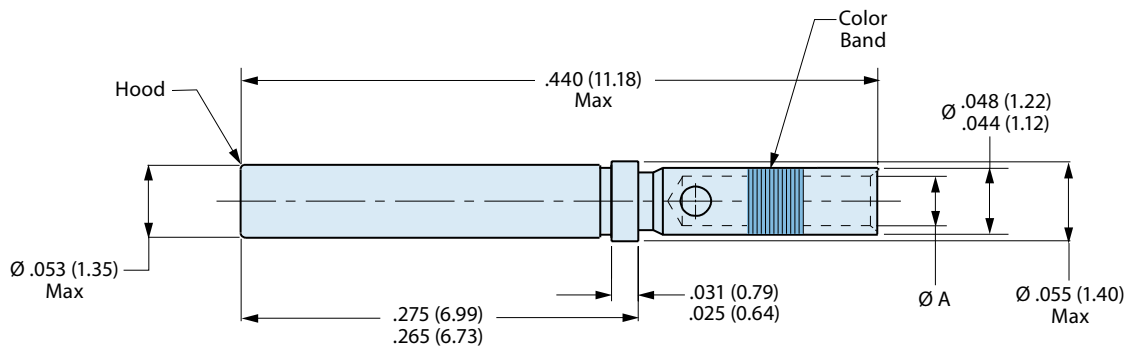

D

CRIMP TENSILE STRENGTH

Values are in pounds and are minimums.

Wire Gage	Silver or Tin Coated Copper Wire	Nickel Coated Copper Wire
#22	12	8
#24	8	6
#26	5	3
#28	3	2
#30	1.5	1.5

Material and Finish

Beryllium copper alloy per ASTM B196 or B197, 50 microinches gold plated per ASTM B488 Type 3 Code C Class 1,27 over nickel plate per QQ-N-290 Class 2, 50-100 microinches. Thermocouple contacts: alumel or chromel alloy, unplated, per ANSI 96.1 Socket contact hood: stainless steel, passivated per AMS-QQ-P-35.

Specifications

Current Rating: 5 Amps maximum
Voltage Drop (at 5 Amps and 25° C): 70 millivolts maximum
Temperature Range: -65° to + 200° C
Socket Contact Minimum Separation Force: 0.5 ounces

Crimp Tools and Insertion/Extraction Tools

Crimper: 809-015 or AFM8
Positioner: 809-005 (std). Use P/N 809-057 for small bore contacts 809-065 and 809-066
Standard Insertion/Extraction Tool: 809-088



830-004 and 830-005 Size #12 Pneumatic Socket Contacts

Size #12 Pneumatic Contacts



Contact Type	For Use With	Tube I.D.	Part Number
Socket	D38999 Series II, Series 79 and Series 80	.094 (2.38)	830-004
Socket	D38999 Series I, III, IV	.094 (2.38)	830-005

830-004 supercedes 857-010

830-005

830-004

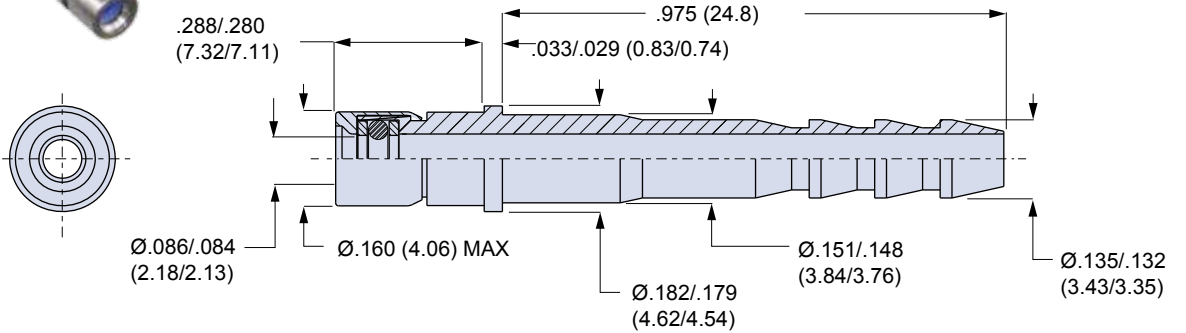

830-005

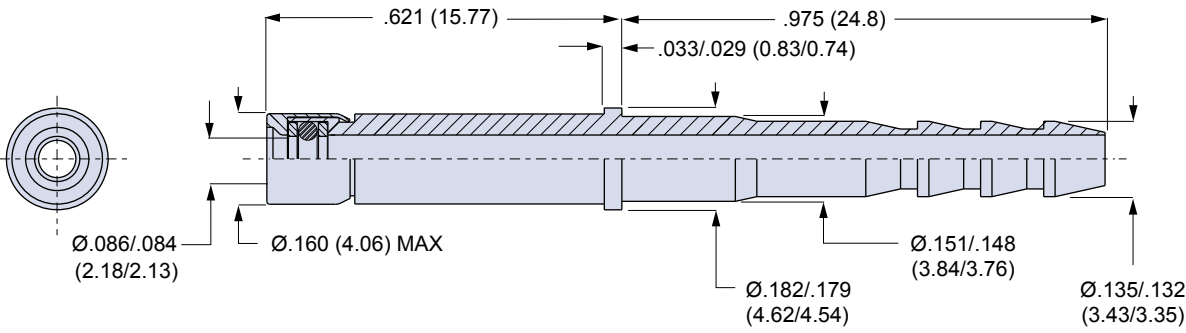

Stainless steel pneumatic contacts attach to 3/32 inch (2.38) diameter tubing. Socket contact has o-ring and PTFE backup washers. Contacts snap into size #12 connector cavities. These pneumatic contacts are rated for 100 PSI maximum air pressure. No installation tool is required. Remove contacts with plastic extraction tool 809-132.

Material and Finish

Body and Cap: stainless steel, passivated
O-ring: fluorosilicone
Washers: PTFE

Specifications

Contact may be used for air pressures up to 100±10% PSIG
Fits #12 socket contact cavities (see description for details)

Notes

High pressure pneumatic contacts available. Consult factory for more information.

830-003
Size #12 Pneumatic Pin Contact



Special Purpose

Size #12 Pneumatic Contacts



Contact Type	For Use With	Tube I.D.	Part Number
Pin	D38999 All Series, Series 79 and Series 80	.094 (2.38)	830-003

830-003 supercedes 857-011

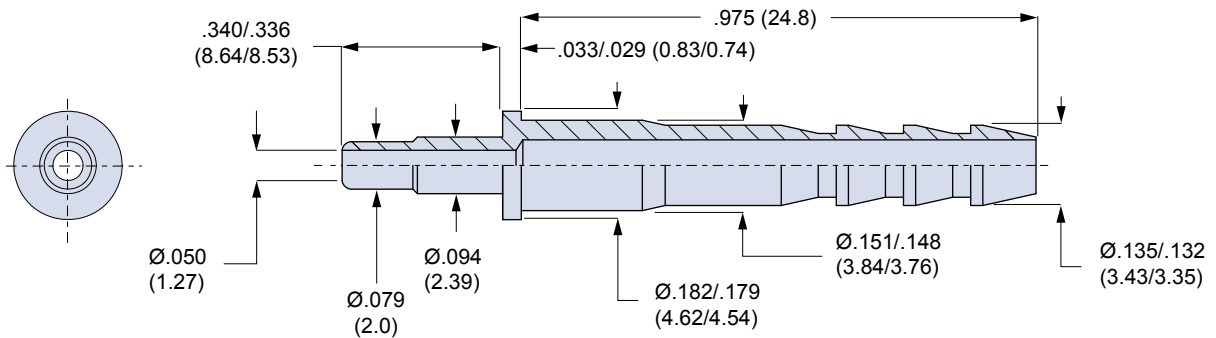

Stainless steel pneumatic contacts attach to 3/32 inch (2.38) diameter tubing. Contacts snap into size #12 connector cavities. These pneumatic contacts are rated for 100 PSI maximum air pressure. No installation tool is required. Remove contacts with plastic extraction tool 809-132.

Material and Finish

Body and Cap: stainless steel, passivated
 O-ring: fluorosilicone
 Washers: PTFE

Specifications

Contact may be used for air pressures up to 100±10% PSIG
 Fits #12 socket contact cavities in Series 79 connectors

Notes

High pressure pneumatic contacts available. Consult factory for more information.



857-010
Size #12 Pneumatic Socket Contact

Size #12 Pneumatic Contacts



Contact Type	Tube I.D.	Part Number
Socket	.094 (2.38)	857-010

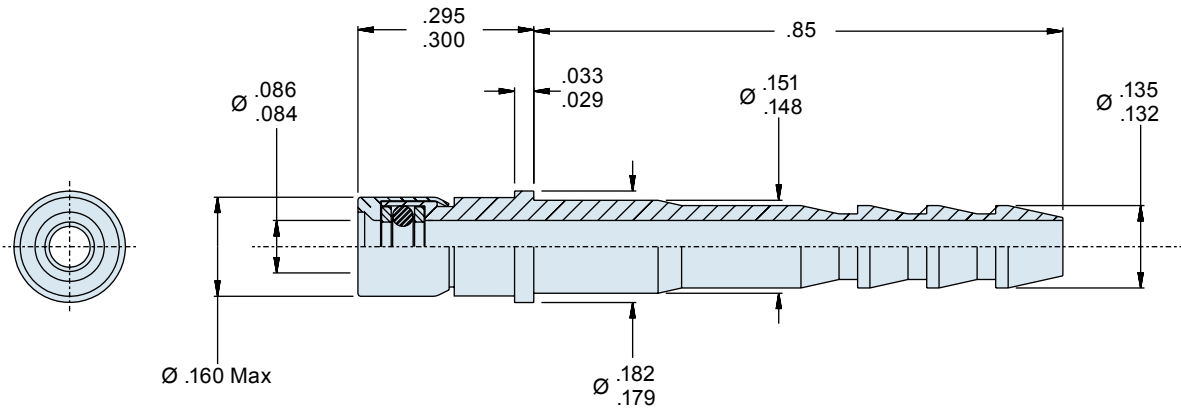

D

Stainless steel pneumatic contacts attach to 3/32 inch (2.38) diameter tubing. Socket contact has o-ring and PTFE backup washers. Contacts snap into size #12 connector cavities. These pneumatic contacts are rated for 200 PSI maximum air pressure. No installation tool is required. Remove contacts with plastic extraction tool 809-132.

Material and Finish

Body and Cap: stainless steel, passivated
O-ring: fluorosilicone
Washers: PTFE

Specifications

Contact may be used for air pressures up to 200±10% PSIG
Fits #12 socket contact cavities in Series 79 connectors

Notes

High pressure pneumatic contacts available. Consult factory for more information.

857-011
Size #12 Pneumatic Pin Contact



Special Purpose

Size #12 Pneumatic Contacts



Contact Type	Tube I.D.	Part Number
Pin	.094 (2.38)	857-011

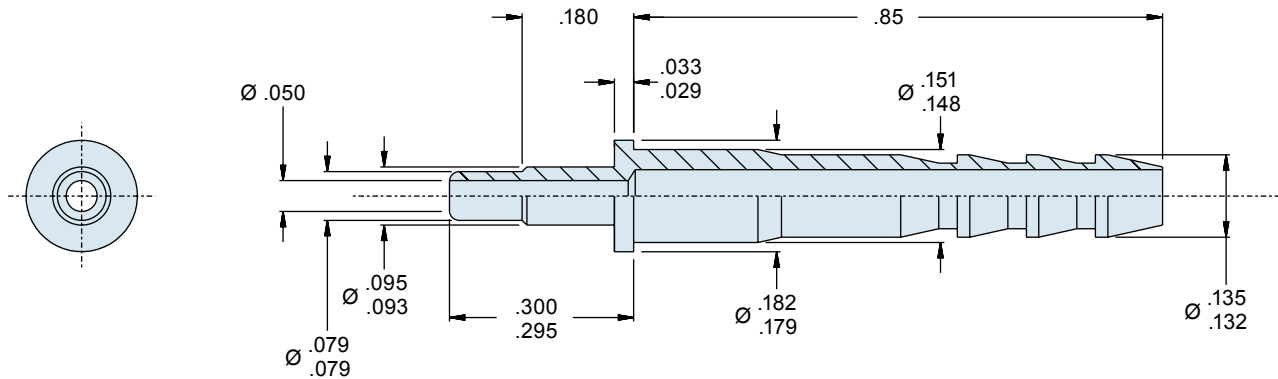

Stainless steel pneumatic contacts attach to 3/32 inch (2.38) diameter tubing. Contacts snap into size #12 connector cavities. These pneumatic contacts are rated for 200 PSI maximum air pressure. No installation tool is required. Remove contacts with plastic extraction tool 809-132.

Material and Finish

Body and Cap: stainless steel, passivated
 O-ring: fluorosilicone
 Washers: PTFE

Specifications

Contact may be used for air pressures up to 200±10% PSIG
 Fits #12 socket contact cavities in Series 79 connectors

Notes

High pressure pneumatic contacts available. Consult factory for more information.



PCB Pin Contact to Fit MIL-DTL-38999/20 and /24 Connectors



Mating End Size	Glenair Part Number
22	850-010-22
20	850-010-20
16	850-010-16
12	850-010-12

TABLE I				
Size	Ø A	Ø B	Ø C	Ø D
22	.0305	.062	.046	.020
	.0295	.060	.044	.018
20	.041	.094	.070	.028
	.039	.091	.068	.024
16	.0635	.130	.101	.0635
	.0615	.127	.097	.0615
12	.095	.182	.134	.095
	.093	.179	.130	.093

D

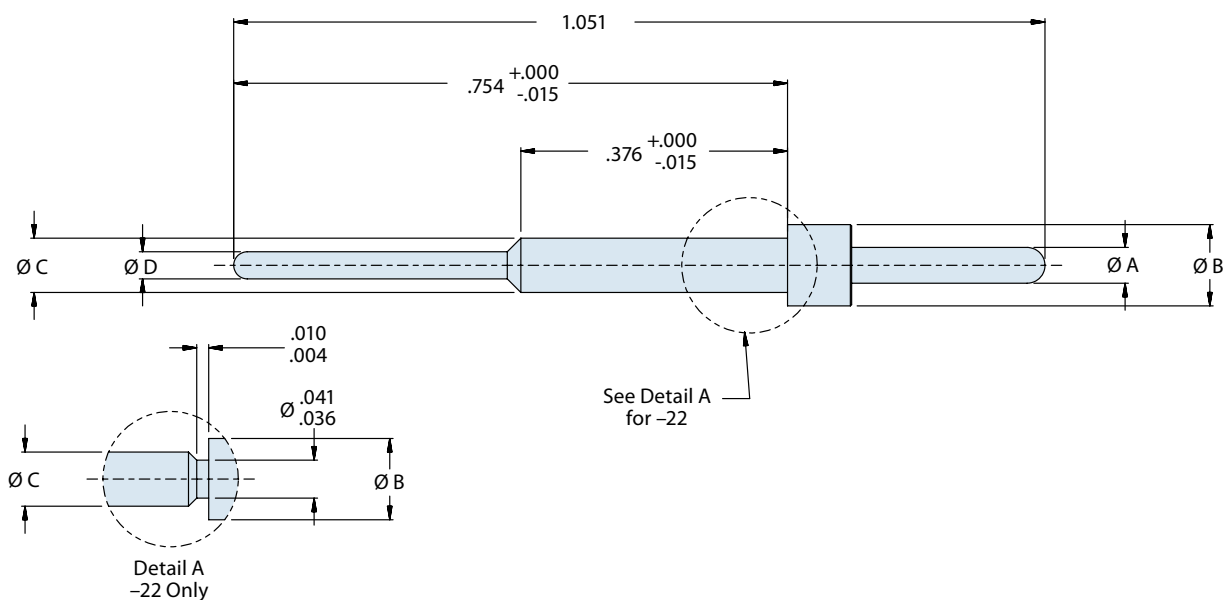

Material and Finish

Copper alloy, plated with 50 microinches gold per ASTM B488 Type II code C over 50–100 micro inches nickel IAW SAE AMS-QQ-N-290, class II

850-011
M39029/56 Type
PCB Socket Contact for D38999/20 and /24



Special Purpose

PCB Socket Contact to Fit MIL-DTL-38999/20 and /24 Connectors



Mating End Size	Glenair Part Number
22	850-011-22
20	850-011-20
16	850-011-16
12	850-011-12

TABLE I				
Size	Ø A Max	Ø B	Ø C	Ø D
22	.062	.062 .060	.046 .044	.020 .018
20	.078	.094 .091	.070 .068	.028 .024
16	.113	.130 .127	.101 .097	.0635 .0615
12	.161	.182 .179	.134 .130	.095 .093

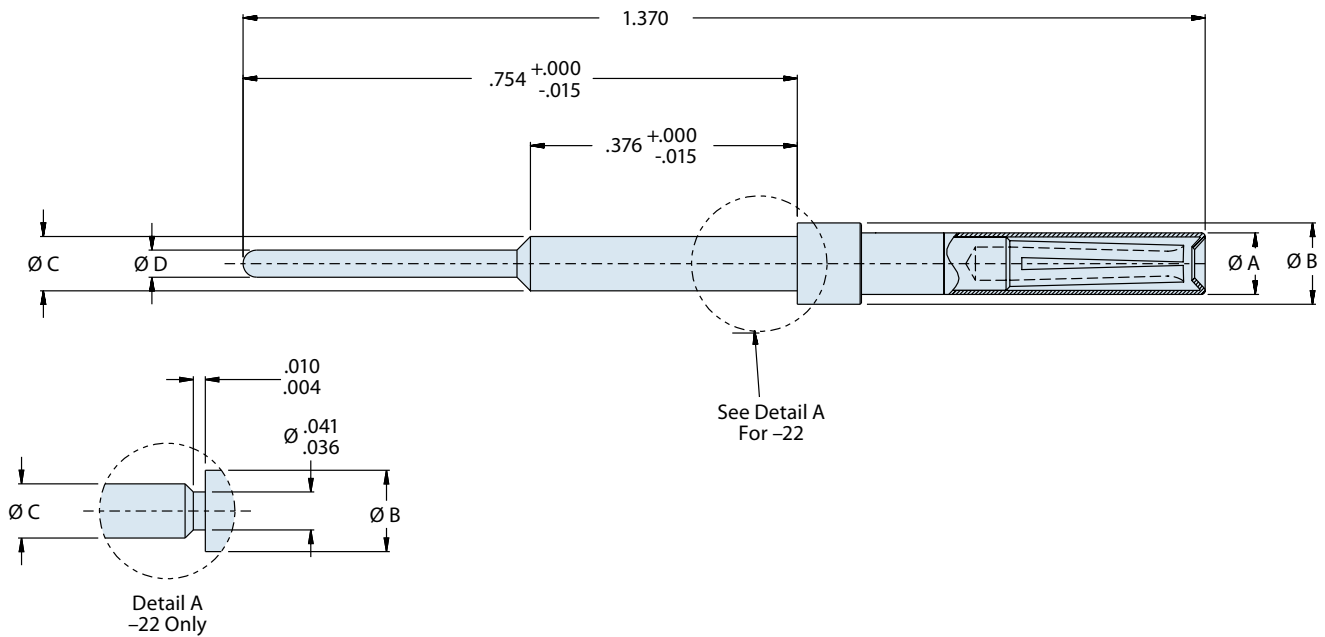

Material and Finish

Copper alloy, plated with 50 microinches gold per ASTM B488 Type II code C over 50–100 microinches nickel IAW SAE AMS-QQ-N-290, class II

850-014
Size 8 Pin Contact
High Power



Special Purpose

#8 High Power Pin Contact



Mating End Size	Wire Accommodations	Glenair Part Number
8	8 AWG	850-014

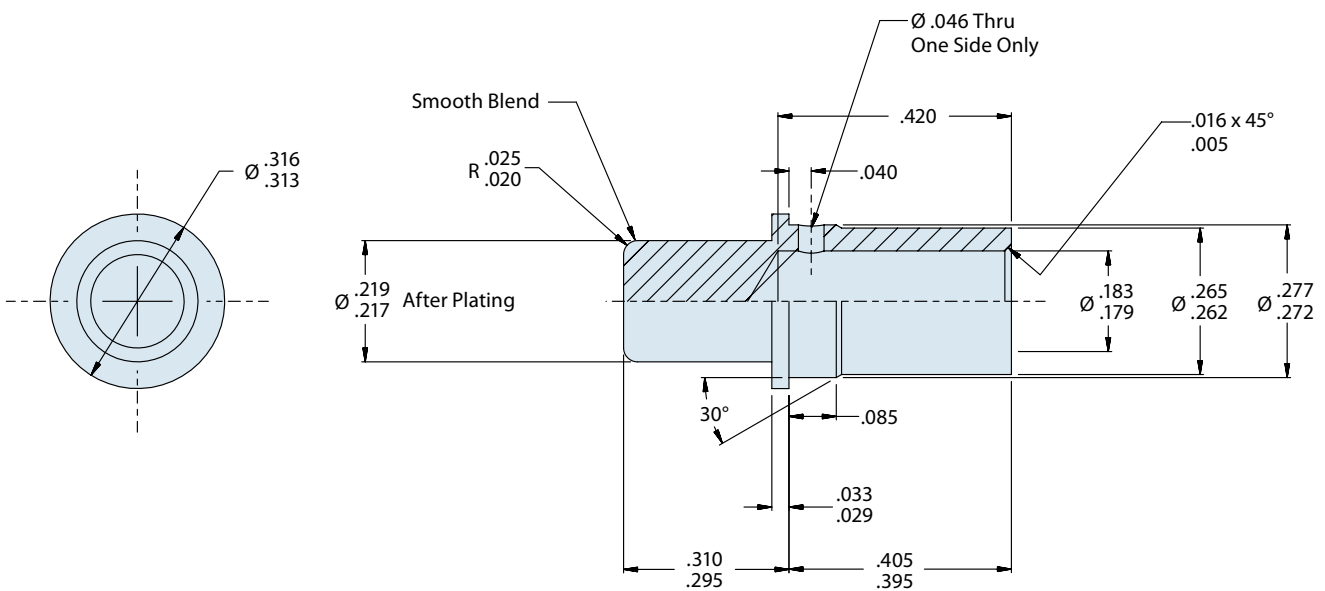

Material and Finish

Contact Body: Copper alloy, plated with 50 microinches gold per ASTM B488 Type II code C over 50–100 microinches nickel IAW SAE AMS-QQ-N-290, class II

Crimp Tools and Insertion/Extraction Tools

From Pico Corporation
 Crimp Tool: 500-D-1
 Crimp Die: 514DA-8N
 Consult factory for cable accommodation and respective tool compatibility.

Notes

For use with Glenair 257-722 series power connectors.





Socket Contact with Solder Cup For D38999 Series I, III and IV Connectors



Mating End Size	Glenair Part Number
22	850-015-22
20	850-015-20
16	850-015-16
12	850-015-12
10	850-015-10

D

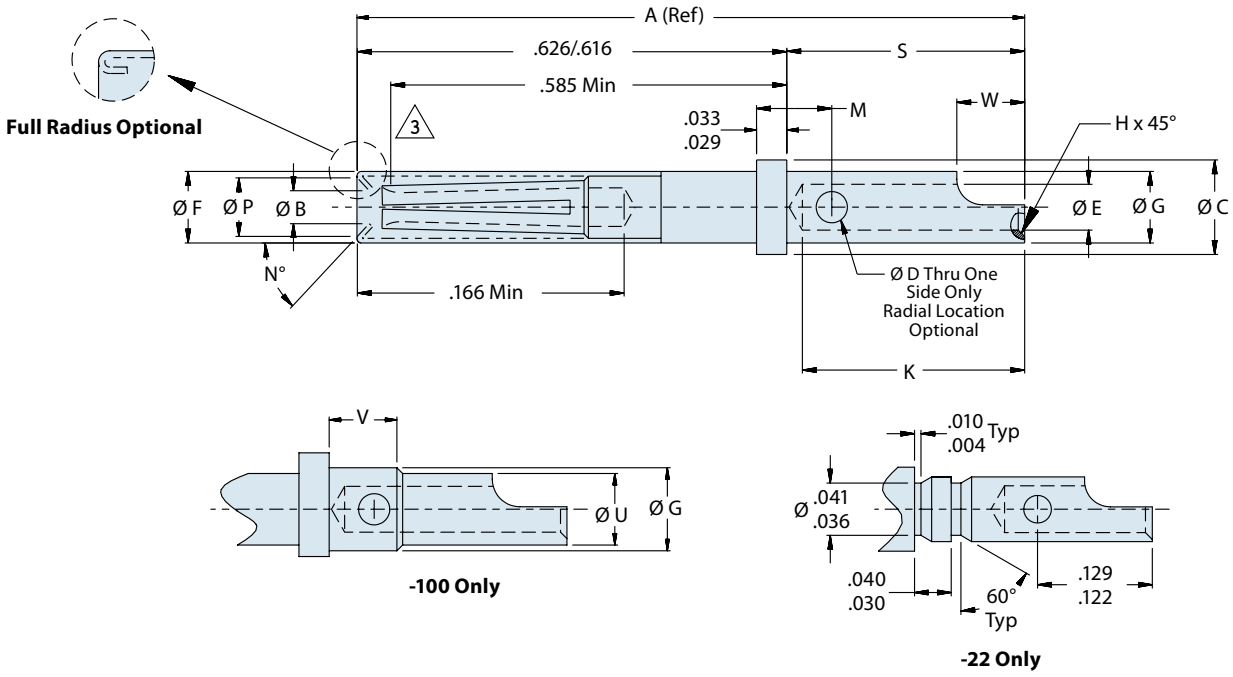

Material and Finish

Contact Body: Copper alloy, plated with 50 microinches gold per ASTM B488 Type II code C over 50–100 microinches nickel IAW SAE AMS-QQ-N-290, class II
Hood: 305 CRES, passivated

850-015
M39029/56 Type
Socket Contact With Solder Cup



Special
Purpose

TABLE I: CONNECTOR DIMENSIONS

Size	Part Number	A Ref	Ø B Min	Ø C	Ø D	Ø E	Ø F Max	Ø G	Ø H
22	850-015-22	.855	.031	.062 .060	.022 .018	.036 .034	.062	.048 .046	.005 .003
20	850-015-20	.855	.0415	.094 .091	.032 .026	.048 .042	.078	.070 .068	.010 .005
16	850-015-16	.855	.064	.130 .127	.042 .036	.080 .070	.113	.103 .101	.010 .005
12	850-015-12	.855	.0955	.182 .179	.042 .036	.120 .112	.161	.151 .148	.016 .005
10	850-015-10	1.021	.1265	.242 .238	.052 .046	.146 .138	.215	.213 .207	.016 .005

TABLE I: (Continued) CONNECTOR DIMENSIONS

Size	Part Number	K	M	N°	Ø P Min	S	Ø U	V	W
22	850-015-22	.160 .130	—	50° 44°	.047	.237 .231	—	—	.080 .050
20	850-015-20	.230 .200	.078 .072	47° 40°	.053	.237 .231	—	—	.105 .075
16	850-015-16	.230 .200	.088 .082	47° 40°	.084	.237 .231	—	—	.105 .075
12	850-015-12	.230 .200	.088 .082	47° 40°	.118	.237 .231	—	—	.115 .085
10	850-015-10	.385 .355	.115 .108	Full Radius	.146	.405 .395	.183 .177	.121 .111	.140 .110

D



Pin Contact with Solder Cup for D38999 Series I, III and IV Connectors



Mating End Size	Glenair Part Number
22	850-016-22
20	850-016-20
16	850-016-16
12	850-016-12
10	850-016-10

D

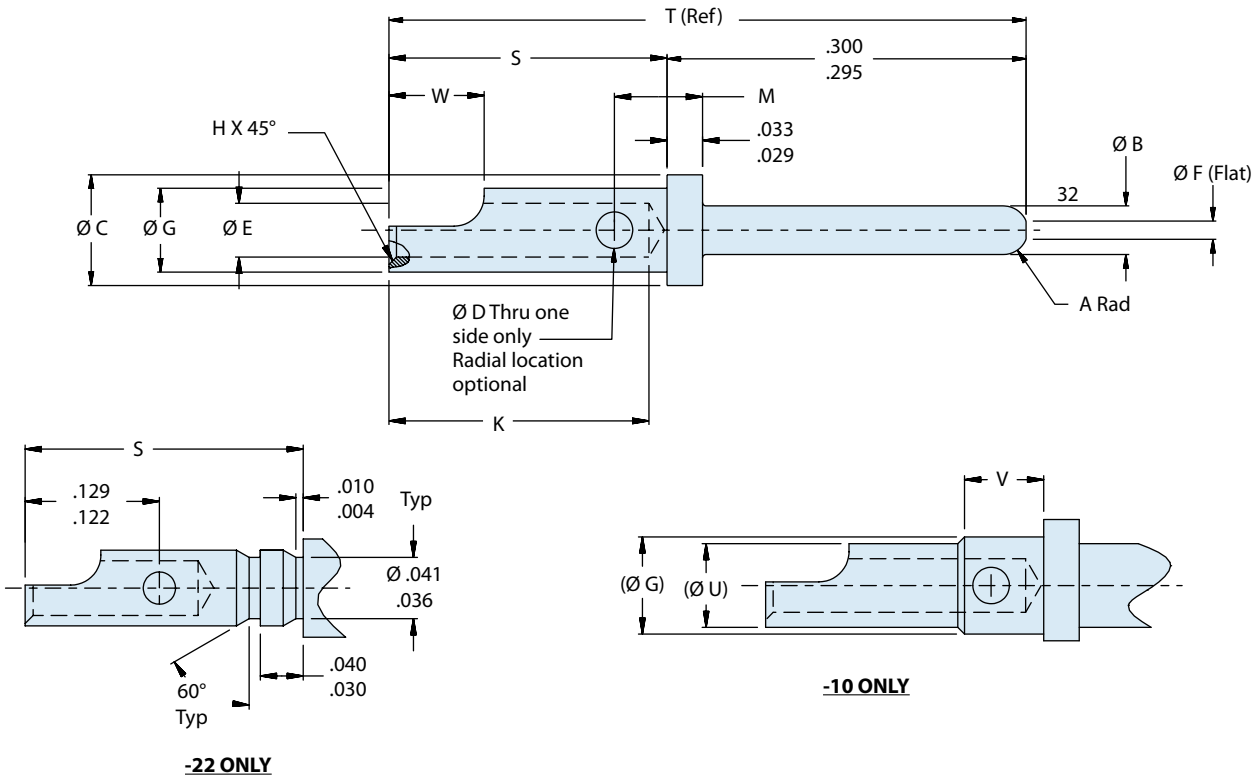

Material and Finish

Contact Body: Copper alloy, plated with 50 microinches gold per ASTM B488 Type II code C over 50-100 microinches nickel IAW SAE AMS-QQ-N-290, class II

850-016
M39029/58 Type
Pin Contact With Solder Cup



Special
Purpose

TABLE I: CONNECTOR DIMENSIONS

Size	Part Number	A Rad	Ø B	Ø C	Ø D	Ø E	Ø F	Ø G	H
22	850-016-22	.020 .010	.0305 .0295	.062 .060	.022 .018	.036 .034	.011 max	.048 .046	.005 .003
20	850-016-20	.025 .020	.041 .039	.094 .091	.032 .026	.048 .042	.015 max	.070 .068	.010 .005
16	850-016-16	.025 .020	.0635 .0616	.130 .127	.042 .036	.080 .070	.030 .011	.103 .101	.010 .005
12	850-016-12	.025 .020	.095 .093	.182 .179	.042 .036	.120 .112	.062 .043	.151 .148	.016 .005
10	850-016-10	.025 .020	.126 .124	.242 .238	.052 .046	.146 .138	.094 .074	.213 .207	.016 .005

TABLE I: (Continued) CONNECTOR DIMENSIONS

Size	Part Number	K	M	S	T (Ref)	Ø U	V	W
22	850-016-22	.160 .130	—	.237 .231	.531	—	—	.080 .050
20	850-016-20	.230 .200	.078 .072	.237 .231	.531	—	—	.105 .075
16	850-016-16	.230 .200	.088 .082	.237 .231	.531	—	—	.105 .075
12	850-016-12	.230 .200	.088 .082	.237 .231	.531	—	—	.115 .085
10	850-016-10	.385 .355	.115 .108	.405 .395	.698	.183 .177	.121 .111	.140 .110

D



Pin Contact with Extended Rear Solder Cup



Mating End Size	Military Part Number	Glenair Part Number
22	N/A	850-017-22
20	N/A	850-017-20
16	N/A	850-017-16
12	N/A	850-017-12

D

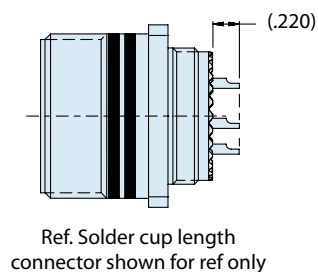
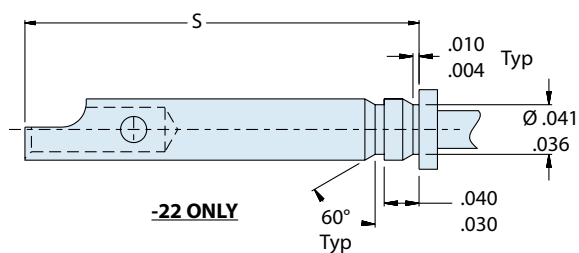
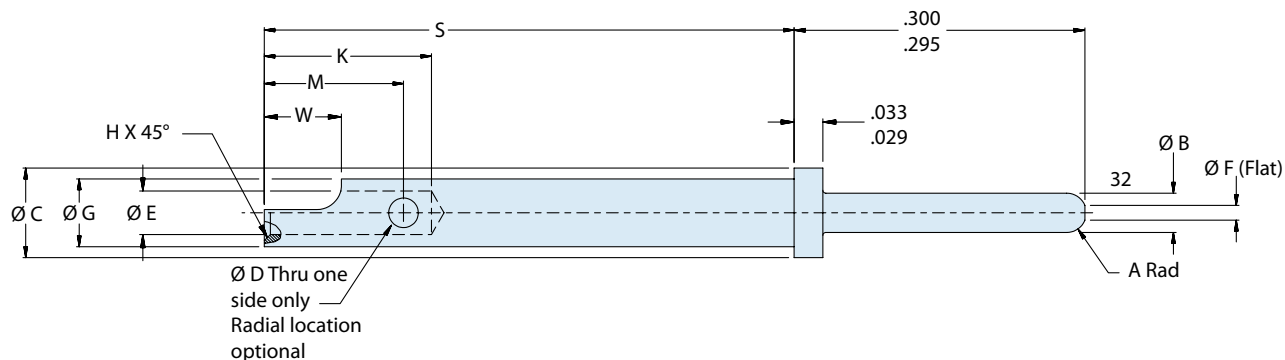

850-017
M39029/58 Type
Pin Contact With Extended Rear Solder Cup



Special
Purpose

TABLE I: CONNECTOR DIMENSIONS

Size	Part Number	A Rad	Ø B	Ø C	Ø D	Ø E	Ø F	Ø G	H	K	M	S	W
22	850-017-22	.020	.0305	.062	.022	.036	.011	.048	.005	.160	.125	.780	.080
		.010	.0295	.060	.018	.034	max	.046	.003	.130			.050
20	850-017-20	.025	.041	.094	.032	.048	.015	.070	.010	.230	.185	.780	.105
		.020	.039	.091	.026	.042	max	.068	.005	.200			.075
16	850-017-16	.025	.0635	.130	.042	.080	.030	.103	.010	.230	.180	.780	.105
		.020	.0616	.127	.036	.070	.011	.101	.005	.200			.075
12	850-017-12	.025	.095	.182	.042	.120	.062	.151	.016	.230	.180	.780	.115
		.020	.093	.179	.036	.112	.043	.148	.005	.200			.085

D

Material and Finish

Contact Body: Copper alloy, plated with 50 microinches gold per ASTM B488 Type II code C over 50–100 microinches nickel IAW SAE AMS-QQ-N-290, class II



850-018-22
M39029/56-348 Type
Size 22 Socket Contact with Expanded Wire Accommodation



Mating End Size	Glenair Part Number
22	850-018-22

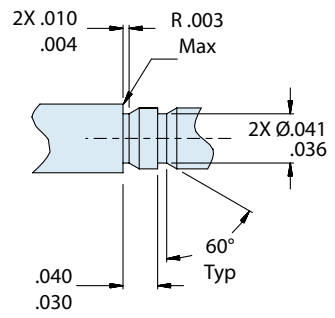
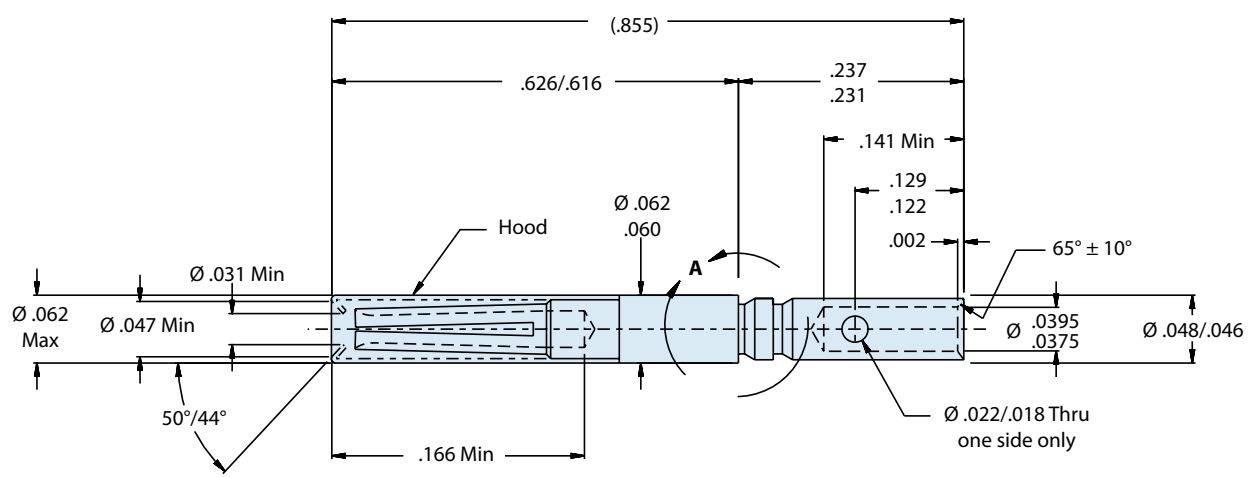

Material and Finish

Contact Body: Copper alloy, plated with 50 microinches gold per ASTM B488 Type II code C over 50–100 microinches nickel IAW SAE AMS-QQ-N-290, class II
 Hood: 305 CRES, passivated

Notes

May be used with up to 20AWG wire

D

850-019-22
M39029/58-360 Type
Size 22 Pin Contact with Expanded Wire Accommodation



Special Purpose



Mating End Size	Glenair Part Number
22	850-019-22

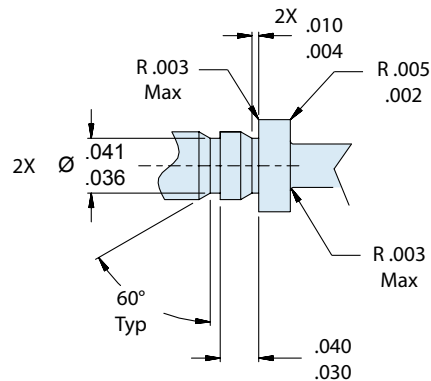
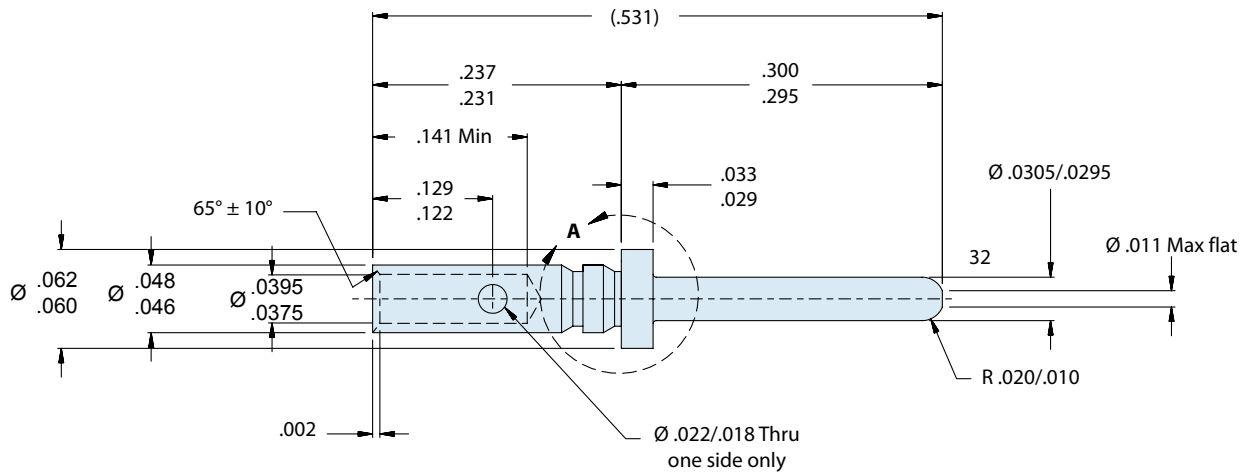

Material and Finish

Contact Body: Copper alloy, plated with 50 microinches gold per ASTM B488 Type II code C over 50-100 microinches nickel IAW SAE AMS-QQ-N-290, class II

Notes

May be used with up to 20AWG wire

D



850-020-22
M39029/57 Type
Socket Contact with Expanded Wire Accommodation



Mating End Size	Glenair Part Number
22	850-020-22

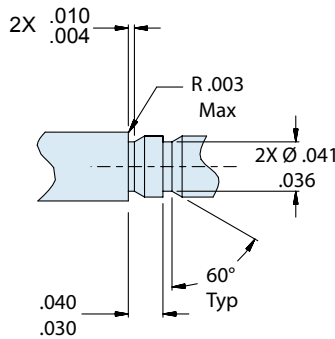
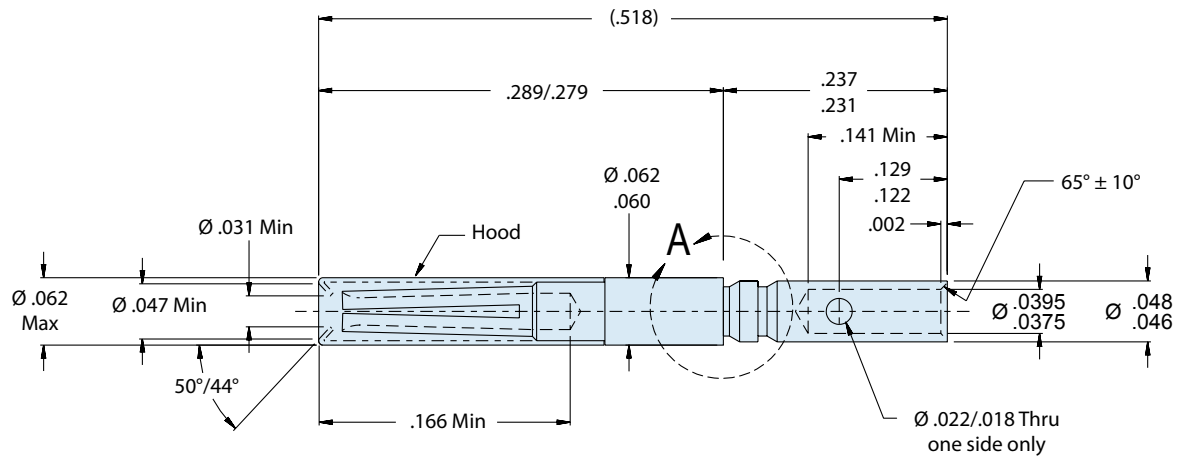

DETAIL A

Material and Finish

Contact Body: Copper alloy, plated with 50 microinches gold per ASTM B488 Type II code C over 50–100 microinches nickel IAW SAE AMS-QQ-N-290, class II
 Hood: 305 CRES, passivated

Notes

May be used with up to 20AWG wire

D

857-027
M39029/58 Type
8 Gauge Pin Contact with PC Tails



Special Purpose



Mating End Size	PC Tail Length (A Dim.)	Overall Length (B Ref)	Glenair Part Number
	.150 (3.8)	1.400 (35.6)	857-027-08-1
8	.225 (5.7)	1.475 (37.5)	857-027-08-2
	.325 (8.3)	1.575 (40.0)	857-027-08-3

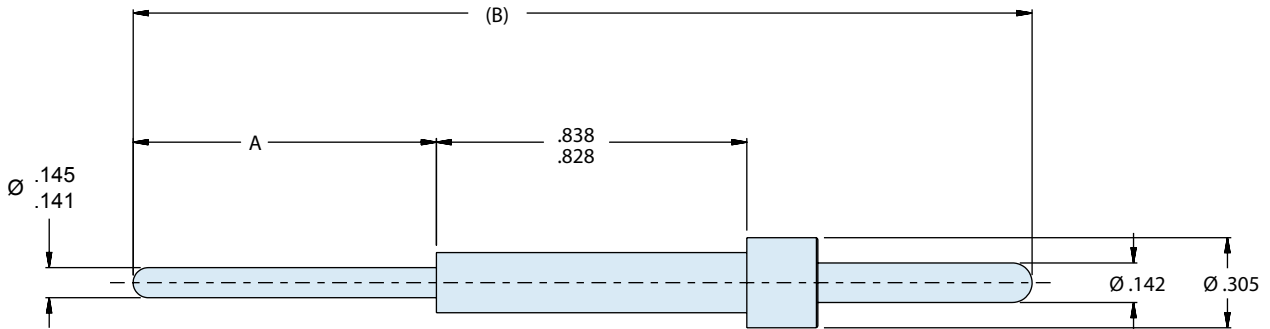

D

Material and Finish

Contact Body: Copper alloy, plated with 50 microinches gold per ASTM B488 Type II code C over 50–100 microinches nickel IAW SAE AMS-QQ-N-290

Notes

This contact is designed IAW M39029/58 and is for use in special MIL-DTL-38999 Series III rear release contact retention systems using 8 gauge power contacts.

Shoulder on PC tail to protrude .030 (nominally) past the grommet seal or end of connector (jam nut type).



857-028
M39029/56 Type
8 Gauge Socket Contact with PC Tails



Mating End Size	PC Tail Length (A Dim.)	Overall Length (B Ref)	Glenair Part Number
8	.150 (3.8)	1.773 (45.0)	857-028-08-1
	.225 (5.7)	1.848 (46.9)	857-028-08-2
	.325 (8.3)	1.948 (49.5)	857-028-08-3

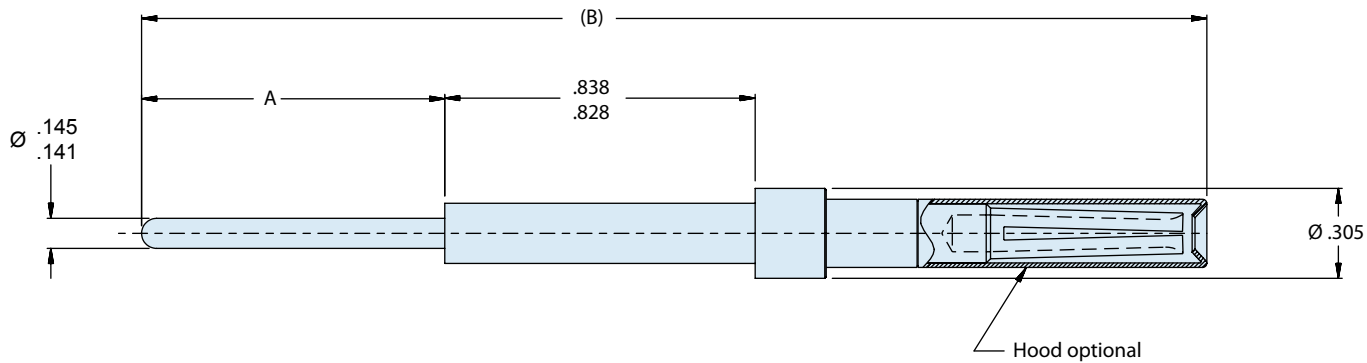

D

Material and Finish

Contact Body: Copper alloy, plated with 50 microinches gold per ASTM B488 Type II code C over 50–100 microinches nickel IAW SAE AMS-QQ-N-290

Notes

This contact is designed IAW M39029/56 and is for use in special MIL-DTL-38999 Series III rear release contact retention systems using 8 gauge power contacts.
 Shoulder on PC tail to protrude .030 (nominally) past the grommet seal or end of connector (jam nut type).

687-348 Wire to Contact Adapter



Special Purpose



687-348 - Basic Part Number	Wire Accommodation	
	6 - 6-8 AWG 10 - 8-10 AWG 12 - 12-14 AWG 16 - 16-18 AWG	20 - 20-22 AWG 22 - 22-24 AWG 0 - 0-4 AWG
687-348	Z2	20
Available Finishes		Contact Wire Barrel Size
Z2 - Gold Plate Z3 - Silver Plate Z4 - Tin Plate		4, 8, 12, 16, 20, 22

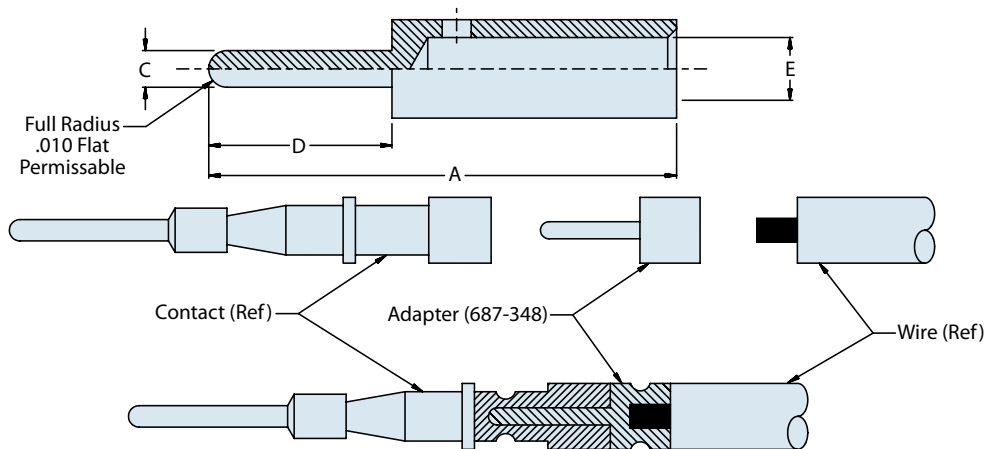

Material and Finish

Contact Body: Tellurium copper alloy with gold, silver or tin plate (see part number development)

Notes

Wire must be crimped or soldered to adapter prior to crimping or soldering electrical contact to adapter. For dimensional data, please consult factory.

Outside diameter may exceed contact crimp-pot diameter, and is therefore not recommended for use in rear release contact style connectors.





Thermocouple Pin Contact to Fit D38999 Series I, II, III and IV Connectors



Mating End Size	Wire Accomodation	Military Part Number	Glenair Part Number
22	22-28 AWG	M39029/87-470	850-023-22-470
22	22-28 AWG	M39029/87-471	850-023-22-471
22	22-28 AWG	M39029/87-472	850-023-22-472
22	22-28 AWG	M39029/87-473	850-023-22-473
20	20-24 AWG	M39029/87-474	850-023-20-474
20	20-24 AWG	M39029/87-475	850-023-20-475
20	20-24 AWG	M39029/87-476	850-023-20-476
20	20-24 AWG	M39029/87-477	850-023-20-477
16	16-20 AWG	M39029/87-478	850-023-16-478
16	16-20 AWG	M39029/87-479	850-023-16-479
16	16-20 AWG	M39029/87-480	850-023-16-480
16	16-20 AWG	M39029/87-481	850-023-16-481

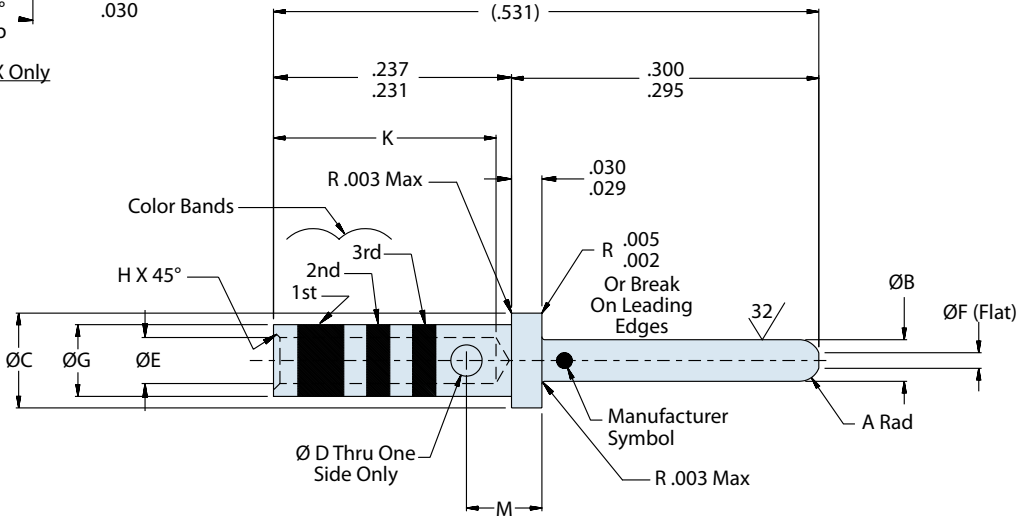
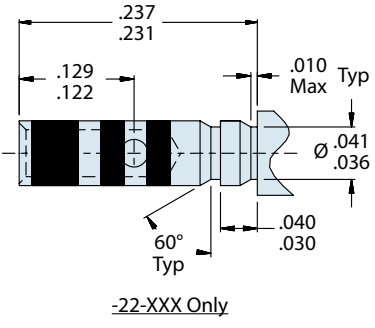

850-023
AS39029/87 Type
Thermocouple Pin Contact



Special Purpose

TABLE I: CONTACT DIMENSIONS

Size	Glenair Part Number	Military Number	A (rad)	ø B Min.	ø C	ø D	ø E	ø F	ø G	H
22	850-023-22-470	M39029/87-470	.020 .010	.0305 .0295	.062 .060	.022 .018	.0355 .0335	.011 max	.048 .046	.005 .003
	850-023-22-471	M39029/87-471								
	850-023-22-472	M39029/87-472								
	850-023-22-473	M39029/87-473								
20	850-023-20-474	M39029/87-474	.025 .015	.041 .039	.094 .091	.032 .026	.048 .046	.015 max	.070 .068	.010 .005
	850-023-20-475	M39029/87-475								
	850-023-20-476	M39029/87-476								
	850-023-20-477	M39029/87-477								
16	850-023-16-478	M39029/87-478	.025 .020	.0635 .0616	.130 .127	.042 .036	.068 .066	.030 .011	.103 .101	.010 .005
	850-023-16-479	M39029/87-479								
	850-023-16-480	M39029/87-480								
	850-023-16-481	M39029/87-481								

TABLE I (Continued): CONTACT DIMENSIONS

Size	Glenair Part Number	Military Number	K	M	Color Bands			Material	Plating
					1st	2nd	3rd		
22	850-023-22-470	M39029/87-470	.157 .141	-	Yellow	Violet	Black	Constantan	None
	850-023-22-471	M39029/87-471			Yellow	Violet	Brown	Alumel	None
	850-023-22-472	M39029/87-472			Yellow	Violet	Red	Chromel	None
	850-023-22-473	M39029/87-473			Yellow	Violet	Orange	Iron	Cadmium Plate*
20	850-023-20-474	M39029/87-474	.229 .209	.078 .072	Yellow	Violet	Yellow	Constantan	None
	850-023-20-475	M39029/87-475			Yellow	Violet	Green	Alumel	None
	850-023-20-476	M39029/87-476			Yellow	Violet	Blue	Chromel	None
	850-023-20-477	M39029/87-477			Yellow	Violet	Violet	Iron	Cadmium Plate*
16	850-023-16-478	M39029/87-478	.229 .209	.088 .082	Yellow	Violet	Gray	Constantan	None
	850-023-16-479	M39029/87-479			Yellow	Violet	White	Alumel	None
	850-023-16-480	M39029/87-480			Yellow	Gray	Black	Chromel	None
	850-023-16-481	M39029/87-481			Yellow	Gray	Brown	Iron	Cadmium Plate*

*Chromate Clear Coat.

TABLE II: TOOL COMPATIBILITY

Size	Glenair Part Number	Military Number	AWG Handling	Crimp Tool	Positioner	Insertion Tool	Extraction Tool
22	850-023-22-470	M39029/87-470	22, 24, 26	M22520/2-01 M22520/7-01	M22520/2-09 M22520/7-07	M81969/14-01 M81969/8-01	M81969/14-01 M81969/8-02
	850-023-22-471	M39029/87-471					
	850-023-22-472	M39029/87-472					
	850-023-22-473	M39029/87-473					
20	850-023-20-474	M39029/87-474	20, 22, 24	M22520/7-01 M22520/2-01 M22520/1-01	M22520/7-08 M22520/2-10 M22520/1-04 (Red)	M81969/8-05 M81969/14-02	M81969/8-06 M81969/14-02
	850-023-20-475	M39029/87-475					
	850-023-20-476	M39029/87-476					
	850-023-20-477	M39029/87-477					
16	850-023-16-478	M39029/87-478	16, 18, 20	M22520/1-01 M22520/7-01	M22520/1-04 (Blue) M22520/7-04	M81969/8-07 M81969/14-03	M81969/8-08 M81969/14-03
	850-023-16-479	M39029/87-479					
	850-023-16-480	M39029/87-480					
	850-023-16-481	M39029/87-481					



850-024
AS39029/88 Type
Thermocouple Socket Contact

D38999
Ser. I, III, IV

Thermocouple Socket Contact to Fit D38999 Series I, III and IV Connectors



Mating End Size	Wire Accomodation	Military Part Number	Glenair Part Number
22	22-28 AWG	M39029/88-482	850-024-22-482
22	22-28 AWG	M39029/88-483	850-024-22-483
22	22-28 AWG	M39029/88-484	850-024-22-484
22	22-28 AWG	M39029/88-485	850-024-22-485
20	20-24 AWG	M39029/88-486	850-024-20-486
20	20-24 AWG	M39029/88-487	850-024-20-487
20	20-24 AWG	M39029/88-488	850-024-20-488
20	20-24 AWG	M39029/88-489	850-024-20-489
16	16-20 AWG	M39029/88-490	850-024-16-490
16	16-20 AWG	M39029/88-491	850-024-16-491
16	16-20 AWG	M39029/88-492	850-024-16-492
16	16-20 AWG	M39029/88-493	850-024-16-493

D

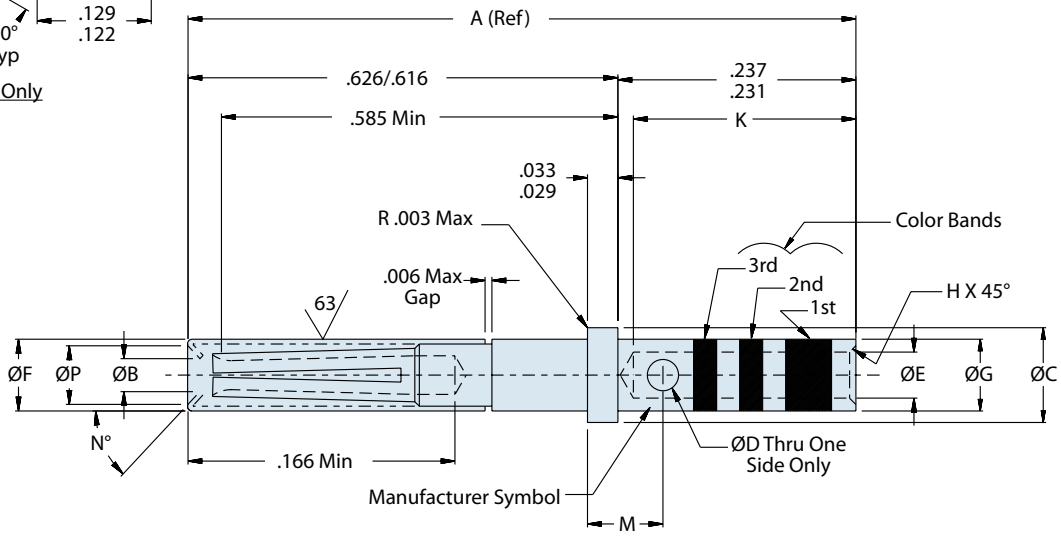
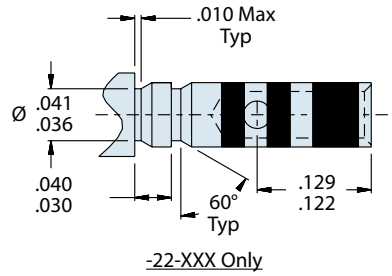

850-024
AS39029/88 Type
Thermocouple Socket Contact



Special Purpose

TABLE I: CONTACT DIMENSIONS

Size	Military Number	Glenair Part Number	A (ref)	ø B	ø C	ø D	ø E	ø F Max	ø G	ø H
22	M39029/88-482	850-024-22-482	.855	.031 Min	.062 .060	.022 .018	.0355 .0335	.062	.048 .046	.005 .003
	M39029/88-483	850-024-22-483								
	M39029/88-484	850-024-22-484								
	M39029/88-485	850-024-22-485								
20	M39029/88-486	850-024-20-486	.855	.044 .042	.094 .091	.032 .026	.048 .046	.078	.070 .068	.010 .005
	M39029/88-487	850-024-20-487								
	M39029/88-488	850-024-20-488								
	M39029/88-489	850-024-20-489								
16	M39029/88-490	850-024-16-490	.855	.064 Min	.130 .127	.042 .036	.068 .066	.113	.103 .101	.010 .005
	M39029/88-491	850-024-16-491								
	M39029/88-492	850-024-16-492								
	M39029/88-493	850-024-16-493								

TABLE I (Continued): CONTACT DIMENSIONS

Size	Military Number	Glenair Part Number	K	M	Color Bands			Material	Plating
					1st	2nd	3rd		
22	M39029/88-482	850-024-22-482	.141 Min	-	Yellow	Gray	Red	Constantan	None
	M39029/88-483	850-024-22-483			Yellow	Gray	Orange	Alumel	None
	M39029/88-484	850-024-22-484			Yellow	Gray	Yellow	Chromel	None
	M39029/88-485	850-024-22-485			Yellow	Gray	Green	Iron	Cadmium Plate*
20	M39029/88-486	850-024-20-486	.229 .209	.078 .072	Yellow	Gray	Blue	Constantan	None
	M39029/88-487	850-024-20-487			Yellow	Gray	Violet	Alumel	None
	M39029/88-488	850-024-20-488			Yellow	Gray	Gray	Chromel	None
	M39029/88-489	850-024-20-489			Yellow	Gray	White	Iron	Cadmium Plate*
16	M39029/88-490	850-024-16-490	.229 .209	.088 .082	Yellow	White	Black	Constantan	None
	M39029/88-491	850-024-16-491			Yellow	White	Brown	Alumel	None
	M39029/88-492	850-024-16-492			Yellow	White	Red	Chromel	None
	M39029/88-493	850-024-16-493			Yellow	White	Orange	Iron	Cadmium Plate*

*Chromate Clear Coat.

TABLE II: TOOL COMPATIBILITY

Size	Military Number	Glenair Part Number	AWG Handling	Crimp Tool	Positioner	Insertion Tool	Extraction Tool
22	M39029/88-482	850-024-22-482	22, 24, 26	M22520/2-01 M22520/7-01	M22520/2-07 M22520//7-05	M81969/14-01 M81969/8-01	M81969/14-01 M81969/8-02
	M39029/88-483	850-024-22-483					
	M39029/88-484	850-024-22-484					
	M39029/88-485	850-024-22-485					
20	M39029/88-486	850-024-20-486	20, 22, 24	M22520/7-01 M22520/2-01 M22520/1-01	M22520/7-08 M22520/2-10 M22520/1-04 (Red)	M81969/8-05 M81969/14-02	M81969/8-06 M81969/14-02
	M39029/88-487	850-024-20-487					
	M39029/88-488	850-024-20-488					
	M39029/88-489	850-024-20-489					
16	M39029/88-490	850-024-16-490	16, 18, 20	M22520/1-01 M22520/7-01	M22520/1-04 (Blue) M22520/7-04	M81969/8-07 M81969/14-03	M81969/8-08 M81969/14-03
	M39029/88-491	850-024-16-491					
	M39029/88-492	850-024-16-492					
	M39029/88-493	850-024-16-493					

D



Thermocouple Socket Contact to Fit D38999 Series II Connectors

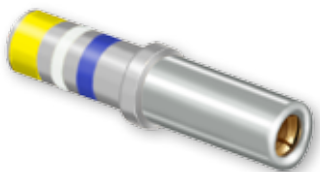

Mating End Size	Wire Accomodation	Military Part Number	Glenair Part Number
22	22-28 AWG	M39029/89-494	850-025-22-494
22	22-28 AWG	M39029/89-495	850-025-22-495
22	22-28 AWG	M39029/89-496	850-025-22-496
22	22-28 AWG	M39029/89-497	850-025-22-497
20	20-24 AWG	M39029/89-498	850-025-20-498
20	20-24 AWG	M39029/89-499	850-025-20-499
20	20-24 AWG	M39029/89-500	850-025-20-500
20	20-24 AWG	M39029/89-501	850-025-20-501
16	16-20 AWG	M39029/89-502	850-025-16-502
16	16-20 AWG	M39029/89-503	850-025-16-503
16	16-20 AWG	M39029/89-504	850-025-16-504
16	16-20 AWG	M39029/89-505	850-025-16-505

D

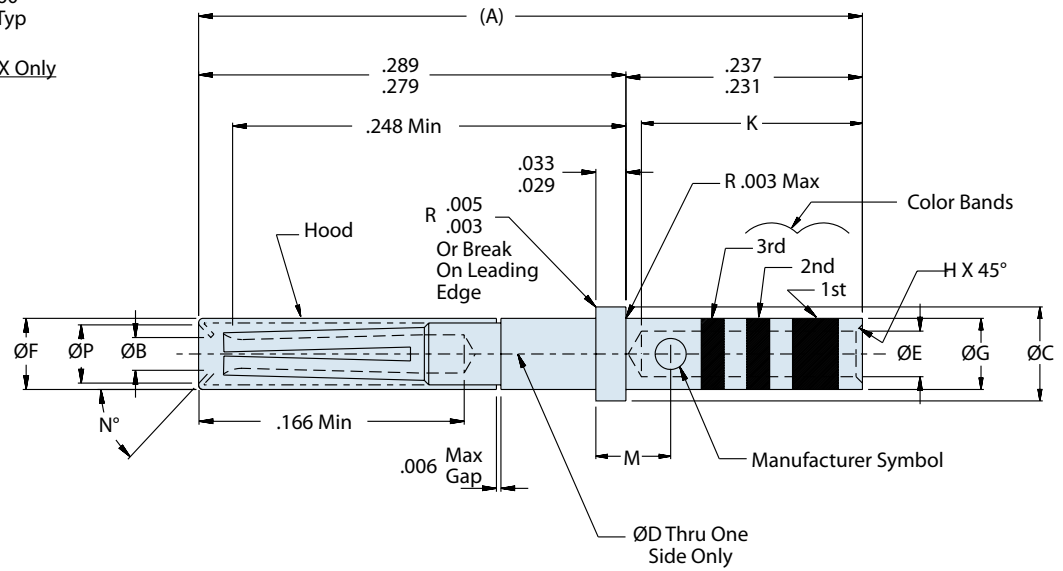
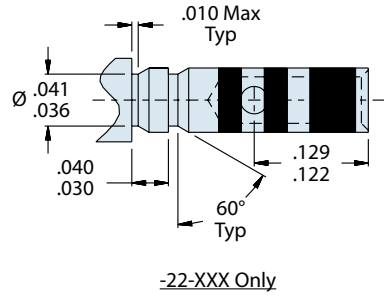

850-025
AS39029/89 Type
Thermocouple Socket Contact



Special Purpose

TABLE I: CONTACT DIMENSIONS

Size	Military Number	Glenair Part Number	A (ref)	ø B Min	ø C	ø D	ø E	ø F Max	ø G	H
22	M39029/89-494	850-025-22-494	.518	.031	.062 .060	.022 .018	.0355 .0335	.062	.048 .046	.005 .003
	M39029/89-495	850-025-22-495								
	M39029/89-496	850-025-22-496								
	M39029/89-497	850-025-22-497								
20	M39029/89-498	850-025-20-498	.518	.0415	.094 .091	.032 .026	.048 .046	.078	.070 .068	.010 .005
	M39029/89-499	850-025-20-499								
	M39029/89-500	850-025-20-500								
	M39029/89-501	850-025-20-501								
16	M39029/89-502	850-025-16-502	.518	.064	.130 .127	.042 .036	.068 .066	.113	.103 .101	.010 .005
	M39029/89-503	850-025-16-503								
	M39029/89-504	850-025-16-504								
	M39029/89-505	850-025-16-505								

TABLE I (Continued): CONTACT DIMENSIONS

Size	Military Number	Glenair Part Number	K Min	M	N°	øP Min	Color Bands			Material	Plating
							1st	2nd	3rd		
22	M39029/89-494	850-025-22-494	.141	-	50° 44°	.047	Yellow	White	Yellow	Constantan	None
	M39029/89-495	850-025-22-495					Yellow	White	Green	Alumel	None
	M39029/89-496	850-025-22-496					Yellow	White	Blue	Chromel	None
	M39029/89-497	850-025-22-497					Yellow	White	Violet	Iron	Cadmium Plate*
20	M39029/89-498	850-025-20-498	.209	.078 .072	47° 28°	.053	Yellow	White	Gray	Constantan	None
	M39029/89-499	850-025-20-499					Yellow	White	White	Alumel	None
	M39029/89-500	850-025-20-500					Green	Black	Black	Chromel	None
	M39029/89-501	850-025-20-501					Green	Black	Brown	Iron	Cadmium Plate*
16	M39029/89-502	850-025-16-502	.209	.088 .082	47° 28°	.084	Green	Black	Red	Constantan	None
	M39029/89-503	850-025-16-503					Green	Black	Orange	Alumel	None
	M39029/89-504	850-025-16-504					Green	Black	Yellow	Chromel	None
	M39029/89-505	850-025-16-505					Green	Black	Green	Iron	Cadmium Plate*

*Chromate Clear Coat.

TABLE II: TOOL COMPATIBILITY

Size	Military Number	Glenair Part Number	AWG Handling	Crimp Tool	Positioner	Insertion Tool	Extraction Tool
22	M39029/89-494	850-025-22-494	22, 24, 26	M22520/2-01 M22520/7-01	M22520/2-06 M22520//7-06	M81969/14-01 M81969/8-01	M81969/14-01 M81969/8-02
	M39029/89-495	850-025-22-495					
	M39029/89-496	850-025-22-496					
	M39029/89-497	850-025-22-497					
20	M39029/89-498	850-025-20-498	20, 22, 24	M22520/7-01 M22520/2-01 M22520/1-01	M22520/7-08 M22520/2-10 M22520/1-04 (Red)	M81969/8-05 M81969/14-02	M81969/8-06 M81969/14-02
	M39029/89-499	850-025-20-499					
	M39029/89-500	850-025-20-500					
	M39029/89-501	850-025-20-501					
16	M39029/89-502	850-025-16-502	16, 18, 20	M22520/1-01 M22520/7-01	M22520/1-04 (Blue) M22520/7-04	M81969/8-07 M81969/14-03	M81969/8-08 M81969/14-03
	M39029/89-503	850-025-16-503					
	M39029/89-504	850-025-16-504					
	M39029/89-505	850-025-16-505					

D



Wire Barrel Reducer Bushing

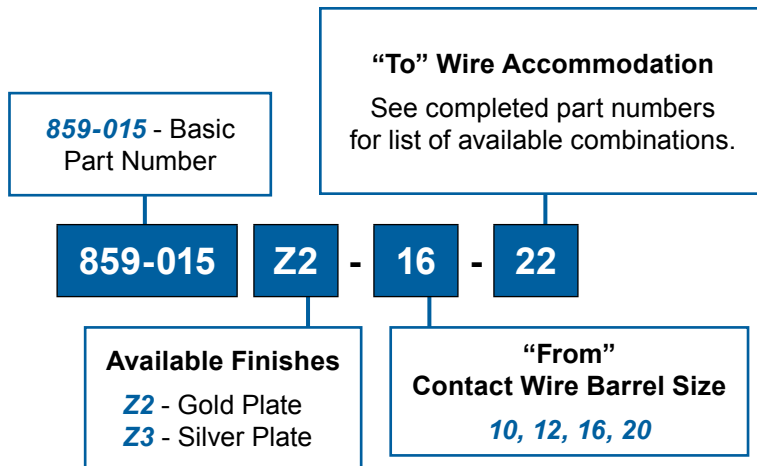

Material and Finish

Copper alloy with gold or silver plate (see part number development)

Notes

Bushings are designed to reduce the barrel size of crimp contacts to accommodate smaller wire gages than specified in M39029.

Bushing must be pressed into contact by hand before crimping.

For proper environmental sealing against the rear connector grommet, use of shrink sleeve or potting may be required.

859-015
Wire Barrel Reducer Bushing
For Use with Crimp Contacts



Special Purpose

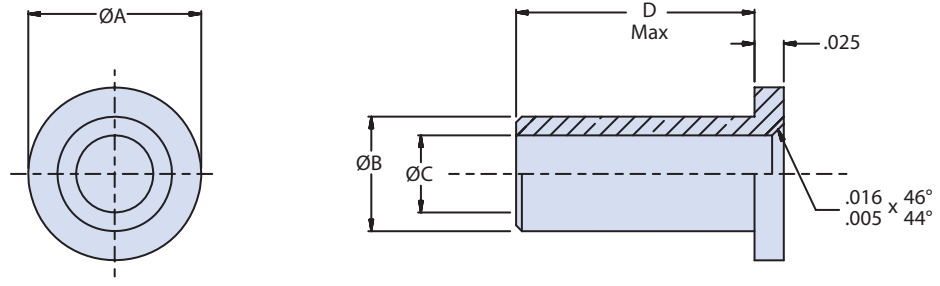

Part Number	Ø A	Ø B	Ø C	D Max
859-015Z2-20-26	.066	.046	.024	.204
859-015Z2-20-28	.066	.046	.019	.204
859-015Z2-16-22	.099	.066	.034	.204
859-015Z2-16-24	.099	.066	.029	.204
859-015Z2-16-26	.099	.066	.024	.204
859-015Z2-16-28	.099	.066	.019	.204
859-015Z2-12-16	.146	.098	.067	.204
859-015Z2-12-18	.146	.098	.056	.204
859-015Z2-12-20	.146	.098	.047	.204
859-015Z2-12-22	.146	.098	.034	.204
859-015Z2-10-12	.177 / .173	.134	.100	.350
859-015Z2-10-16	.177 / .173	.134	.067	.350
859-015Z2-10-20	.177 / .173	.134	.047	.350

D

Contact Size	Standard Wire Accommodation (AWG) Without Bushing
10	10
12	12-14
16	16-20
20	20-24
22	22-28

SERIES 77

FULL NELSON

Heat Shrink Boots

Outstanding Environmental and Mechanical Protection

*“Think he’ll ever break that hold?
Nope. He’s got him in a Full Nelson!”*

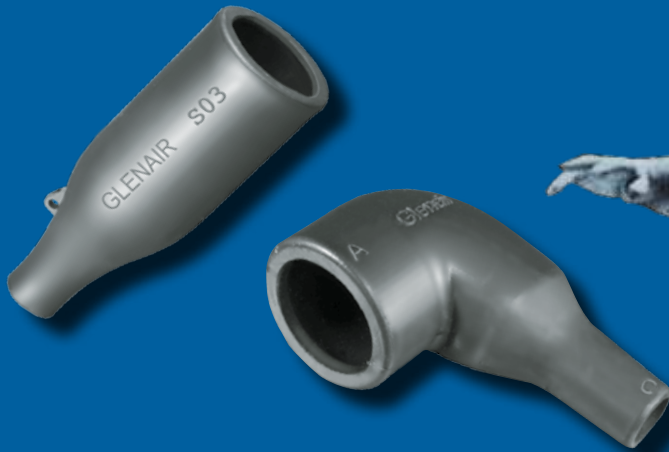

Nothing conjures up the image of an unbreakable hold like a Standing Full Nelson. Properly applied, this classic Greco-Roman wrestling move is simply unbeatable. We’d like to think the same holds true for our Series 77 *Full Nelson* Environmental Shrink Boots. Properly applied, Series 77 boots provide a dependable, leak-proof seal for interconnect cable assemblies. Optional adhesive coatings on the inside of the boot provide a watertight, high-strength bond to the cable jacket and the connector or adapter. And the Glenair shape-memory boot material formula works every time. So if you’re worried about sealing effectiveness, if you want long-lasting environmental protection, if you want an ingress prevention solution that won’t lose its grip after years and years of service, get a Series 77 *Full Nelson*—the environmental shrink boot with the iron grip of a championship wrestler.



Tools and Accessories

Crimp Tools, Positioners, Insertion and Extraction Tools and More

Outstanding Product Availability

Many of the contacts in this book utilize crimping technology to effect contact to wire termination. The non-mating end of a crimp contact (the wire barrel) is a hollow cylinder into which a stripped wire (conductor) is inserted. The sidewalls of the wire barrel are then mechanically compressed (uniformly deformed) using a crimping tool to captivate the stripped wire.

The crimped wire to contact termination can then be manually, or with the assistance of a hand-held tool, clipped into place in the connector. The physical compression (deformation) of a contact barrel around a conductor in order to make an electrical connection must be accomplished in a proscribed and precise manner using the exact tools and accessories to achieve the desired gas tight crimp. This section of the book presents an organized inventory for all the tools and accessories necessary, including contact insertion and extraction tools, for the reliable termination and use of SAE-AS39029 and other industry standard crimp type contacts.



E

- ◆ Industry Standard Crimp Tools and Accessories
- ◆ One-Stop-Tool-Shopping for All Glenair Contact Types and Sizes
- ◆ Outstanding Technical Support and Assembly Procedures
- ◆ Same-Day Availability on Most Popular Tools and Accessories

Miniature Adjustable Crimp Tools



These crimp tools perform precision eight indent crimps for gas tight wire terminations and excellent tensile strength. Adjustment wheel has 8 settings. Ratchet mechanism prevents improper crimps. Use with bayonet type positioners. Check calibration with M22520/3 gages. Length is 6.75 inches, weight is approx. 10 oz.

A Standard M22520/2-01 crimper. Use with standard #23, #22D and #20HD contacts, and with M39029/76 and /78 coaxial center contacts. Requires positioner, ordered separately.

B Special MH992 crimper used with 50 ohm matched impedance coaxial inner contacts. Requires positioner, ordered separately.



Figure	Part Number	Military Part Number	Daniels Part Number
A	809-015	M22520/2-01	AFM8
B	809-128	(none)	MH992

Positioners For Use With Miniature Adjustable Crimp Tools



These bayonet-type positioners hold contacts at correct height for crimping with M22520/2 type miniature step adjustable tools, above. Face plate shows correct tool settings.



Figure	Part Number	Military Part Number	Daniels Part Number	For Use With
C	809-005	(none)	K1461	Size #23 contacts for #22-#28 AWG wire
D	809-057	(none)	(none)	Small bore #23 for #26-#30 AWG wire
E	809-125	M22520/2-35	K532-1	M39029/76 and /78 coax inner contact
F	809-124	(none)	K1360	Matched impedance #12 coax inner contact
G	809-135	M22520/2-34	K323	M39029/27 and /28 coax inner contact
H	859-006	(none)	K1721	Matched impedance #12 coax inner contact. (Use with 809-128 crimp tool)
I	809-206	(none)	(none)	#20HD contacts
Not Shown		M22520/2-10	K43	#20 contact, series I, II, III and IV
		M22520/2-09	K42	#22D contact, series I, II, III and IV Pin
		M22520/2-07	K40	#22D contact, series I, III and IV Socket
		M22520/2-06	K41	#22D contact, series II Socket
		M22520/2-35	K532-1	#16 contact, series I, II, III and IV
	M22520/2-37	K709	Quadrax Inner Contact	

Contact Tools Crimp Tools and Positioners for Coaxial Contacts



Crimp Tool And Positioner For #12, #16 and #20 Power Contacts, Crimp Adapters



J Crimp tool for use with size #20, #16 and #12 power pins. 9.75 inches OAL, 1.25 pounds. Use with M39029/57 and /58 contacts and 809-093 adapters.

K Positioner for use with size #20, #12 and #16 Power contacts.

L Positioner for use with 809-093 Mighty Mouse and Micro Crimp wire adapters.

Figure	Part Number	Military Part Number	Daniels Part Number
J	809-136	M22520/1-01	AF8
K	809-137	M22520/1-04	TH163
L	809-138	(none)	TH653

Crimp Tool And Positioner For #16 Coaxial Outer Contact



For crimping size #16 shield sleeves. These mil spec approved tools feature a ratchet mechanism to prevent damage from over crimping. Check calibration with M22520/3 gage.

M Crimp tool for use with size #16 coaxial contacts. Blue handles. 9.75 inches OAL, 1.25 pounds.

N Positioner for use with size #16 coaxial contacts. Use with 809-127 (M22520/4-01) crimp tool.

Figure	Part Number	Military Part Number	Daniels Part Number
M	809-127	M22520/4-01	GS100-1
N	809-126	M22520/4-02	GP295

Crimp Tool And Positioner For #12 Coaxial Outer Contact



For crimping size #12 shield sleeves. These mil spec approved tools feature a ratchet mechanism to prevent damage from over crimping. Check calibration with M22520/3 gage.

O Crimp tool for use with size #12 coaxial contacts. Black handles. 9.75 inches OAL, 1.25 pounds.

P Positioner for use with size #12 coaxial contacts. Use with 809-133 (M22520/31-01) crimp tool.

Figure	Part Number	Military Part Number	Daniels Part Number
O	809-133	M22520/31-01	GS200-1
P	809-134	M22520/31-02	G2P330

Parallel Action Crimp Tool and Hex Die Set for 50 Ohm Matched Impedance #12 Coax

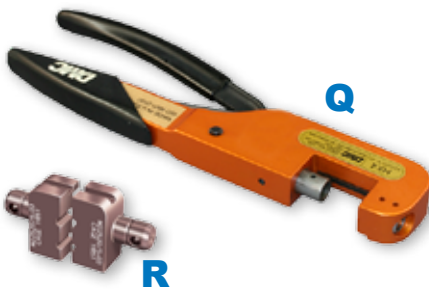

Q Parallel action tool for use with hex crimp dies. 11 inches OAL, 2.0 pounds. Anodized aluminum frame, steel mechanism, plastic handles. Includes tool for die set extraction. Accepts all M22520/5 die sets.

R Die set for terminating coaxial shield to outer contact. Use with size #12 matched impedance M39029/102 and 103 type coaxial contacts. Set consists of upper and lower halves. Made of hardened steel with black oxide finish. Die set has two closures.

Figure	Part Number	Military Part Number	Daniels Part Number
Q	809-129	M22520/5-01	HX4
R	809-130	M22520/5-03	Y196

Contact Insertion and Extraction Tools

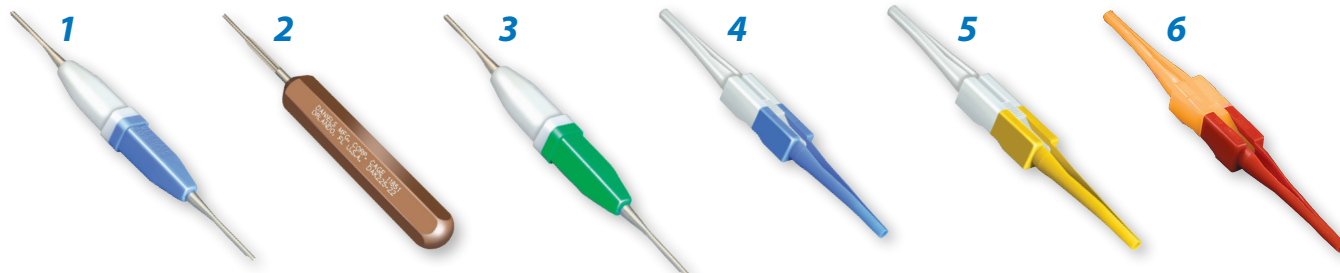

1 Insertion/Extraction Tool for #23 Contacts. This tool features molded plastic grips and sturdy stainless steel tips. Blue/White molded handle.

2 Insertion Tool for #23 Contacts. This tool features anodized aluminum handle and stainless steel insertion tip.

3 Insertion/Extraction Tool for #20HD Contacts. This tool features molded plastic grips and sturdy stainless steel tips. Green/White molded handle.

4 Insertion/Extraction Tool for #16 Contacts. Use with size #16 coaxial or power contacts. Economical molded plastic. White extraction tip, blue insertion tip.

5 Insertion/Extraction Tool for #12 Contacts. Use with size #12 coaxial or power contacts. Molded plastic. White extraction tip, yellow insertion tip.

6 Insertion/Extraction Tool for #20 Contacts. Molded plastic. Orange extraction tip, red insertion tip.

Figure	Size	Type	Part Number	Military Part Number	Daniels Part Number
1	#23	Insertion/Extraction	809-088	(None)	(None)
2	#23	Insertion Only	809-013	(None)	DAK225-22
3	#20HD	Insertion/Extraction	809-203D	(None)	(None)
4	#16	Insertion/Extraction	809-131	M81969/14-03	(None)
5	#12	Insertion/Extraction	809-132	M81969/14-04	(None)
6	#20	Insertion/Extraction	809-207	M81969/14-10	(None)
	#22	Insertion/Extraction	(None)	M81969/14-01	(None)

Contact Retention Tester for Size #23 Contacts



Check for properly seated contacts with this spring-loaded tester. Apply the tool tip to the mating end of a contact. Push on the handle until the spring compresses to the recommended force. A visual indicator shows full compression. The contact is properly retained if it is not displaced.

The adjustable handle should be set to 3.2 pounds (14.2 N). The pin tip is used with #23 pin contacts. The socket tip is used with #23 socket contacts.

Order the complete kit, or order the tips and handle separately.

Figure	Description	Part Number	Daniels Part Number
1	Handle	809-107-1	HT250-2
2	Pin Tip	809-107-2	68-023-01
	Socket Tip (not shown)	809-107-3	67-023-01
	Complete Kit	809-107-4	(None)

182-012
Fiber Optic Crimp Tool



Fiber Optic Terminus Crimping Tool for M29504, GHD, GFOCA and NGCON

The Glenair fiber optic crimping tool enables users to quickly and effectively terminate the crimp sleeve to the cable strength member for a secure mechanical junction. The tool is compatible with many common termini styles, including M29504, Glenair High Density (GHD), GFOCA and NGCON.

Part Number	Compatible Termini
182-012	181-039 M29504/14 Pin
	181-040 M29504/15 Socket
	181-011 #16 Socket
	181-012 #16 Pin
	181-047 Genderless GHD, Keyed
	181-056 Genderless GHD, Non-Keyed
	181-050 Genderless GFOCA
	181-043 Genderless NGCON

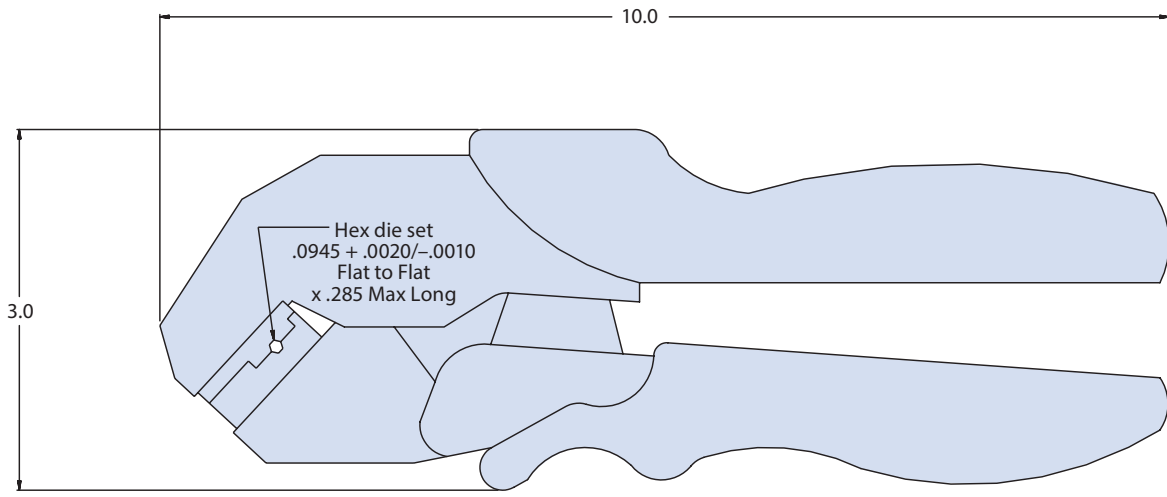



182-013 Straight Insertion Tool For Fiber Optic Termini

Straight Insertion Tool for Fiber Optic Termini

The preferred tool of seasoned fiber optic technicians, the Glenair straight insertion tool is designed to aid users in populating connectors with fiber optic termini. Gone are the days of damaged fibers and sore fingers—this convenient tool features a comfortable handle and specially designed insertion tip for use with M29504, GHD and many other termini available from Glenair.

Part Number	Compatible Termini
182-013	181-039 M29504/14 Pin
	181-040 M29504/15 Socket
	181-051 M29504/03 Dummy
	181-011 #16 Socket
	181-012 #16 Pin
	181-021 #16 Socket
	181-022 #16 Pin
	181-056 Genderless GHD, Non-Keyed

Ø .850
Max

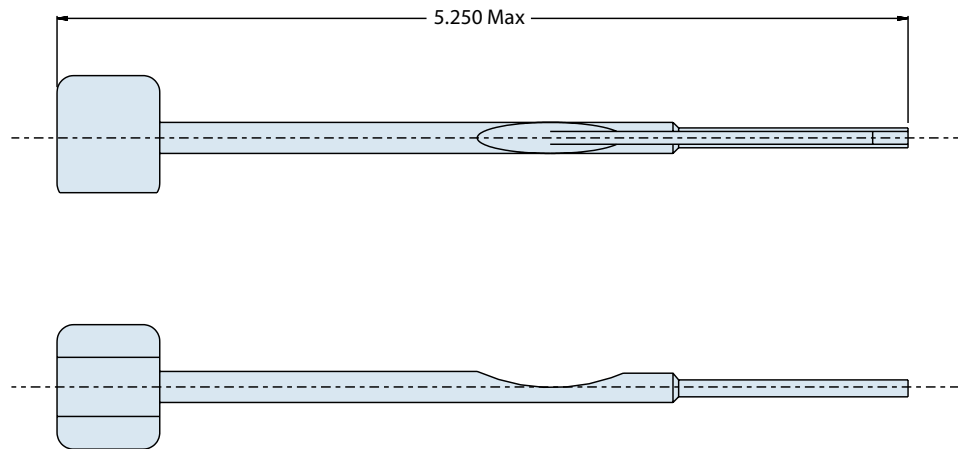
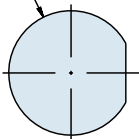

182-014
90° Insertion Tool
For Fiber Optic Termini



Right Angle (90°) Insertion Tool for Fiber Optic Termini

The Glenair 90° terminus insertion tool is designed to help populate connectors with fiber termini in situations where space is limited—while offering users the same easy insertion as with our straight 182-013 tool. Ideal for use in boxes and on connectors with backshells that inhibit normal rear insertion. Designed for use with M29504, GHD and many other termini available from Glenair.

Part Number	Compatible Termini
182-014	181-039 M29504/14 Pin
	181-040 M29504/15 Socket
	181-051 M29504/03 Dummy
	181-011 #16 Socket
	181-012 #16 Pin

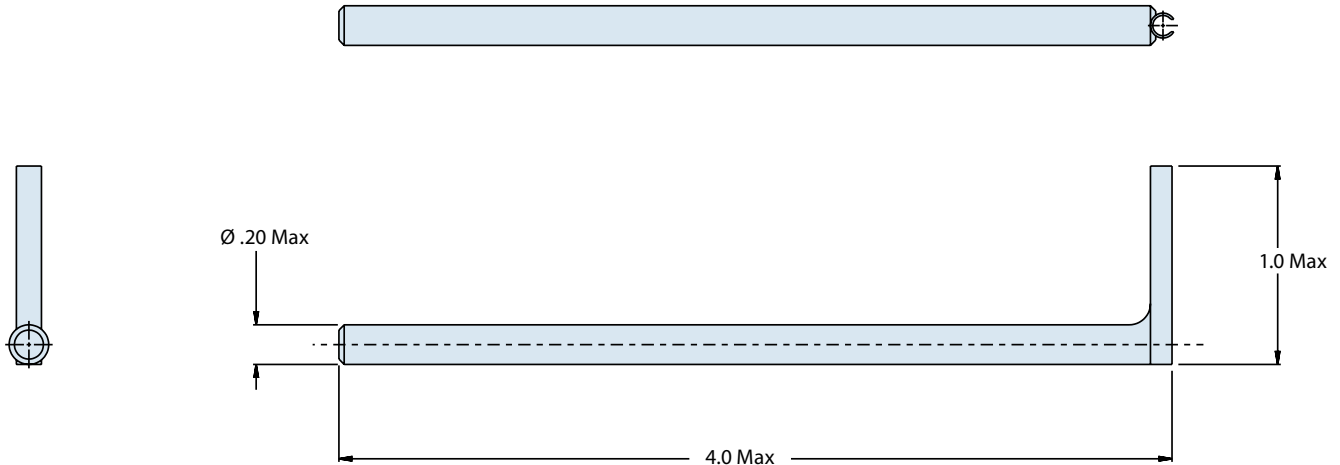

Extraction Tool for Fiber Optic Termini

The Glenair fiber optic terminus extraction tool is designed for use with front release/rear entry termini. Sliding the tool into the face of the insulator and depressing the plunger—after first removing the alignment sleeve with an 182-016 tool—enables users to quickly and easily remove the fiber terminus from the rear of the insert. Compatible with Glenair front release fiber optic termini.

Part Number	Compatible Termini	
182-015	181-039	M29504/14 Pin
	181-040	M29504/15 Socket
	181-051	M29504/03 Dummy
	181-011	#16 Socket
	181-012	#16 Pin

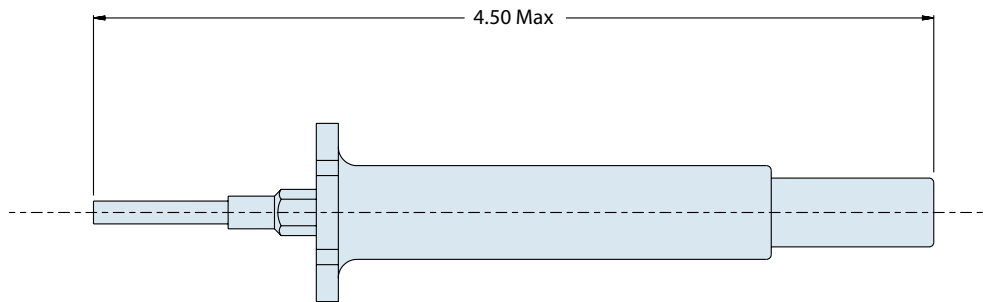
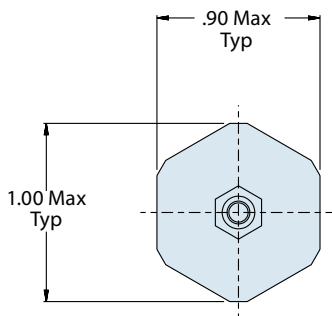

182-016
Alignment Sleeve Insertion/Extraction Tool
For Fiber Optic Termini



Alignment Sleeve Insertion/Extraction Tool for Fiber Optic Termini

The Glenair alignment sleeve extraction tool utilizes a special claw to extract alignment sleeves from the face of front-release fiber optic inserts. Users are afforded easy serviceability of front release termini by sliding the tool's tip into the front of the insert, depressing the plunger, allowing the claws to purchase on the alignment sleeve, then gently pulling away from the face of the connector. Used in conjunction with 182-015 terminus extraction tool.

Part Number	Compatible Termini	
182-016	181-040	M29504/15 Socket
	181-011	#16 Socket

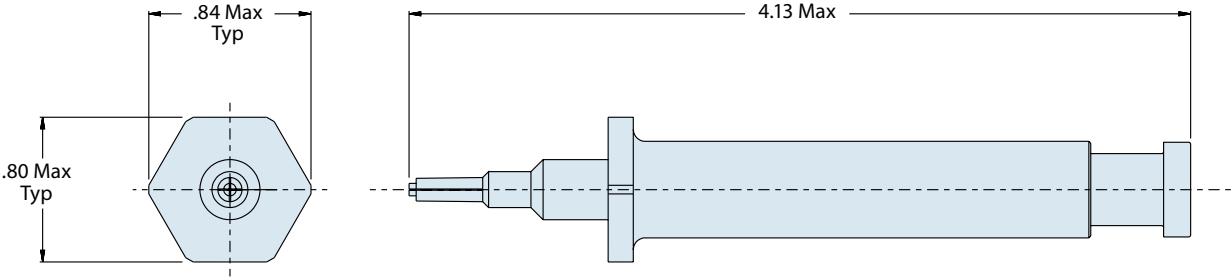

BAND-IT

THE EMI/RFI BRAID BANDING SOLUTION

**High-Speed Termination of EMI/RFI
Cable Shielding (Screening) with Easy to
Use *BAND-IT*® Tools and Bands.**

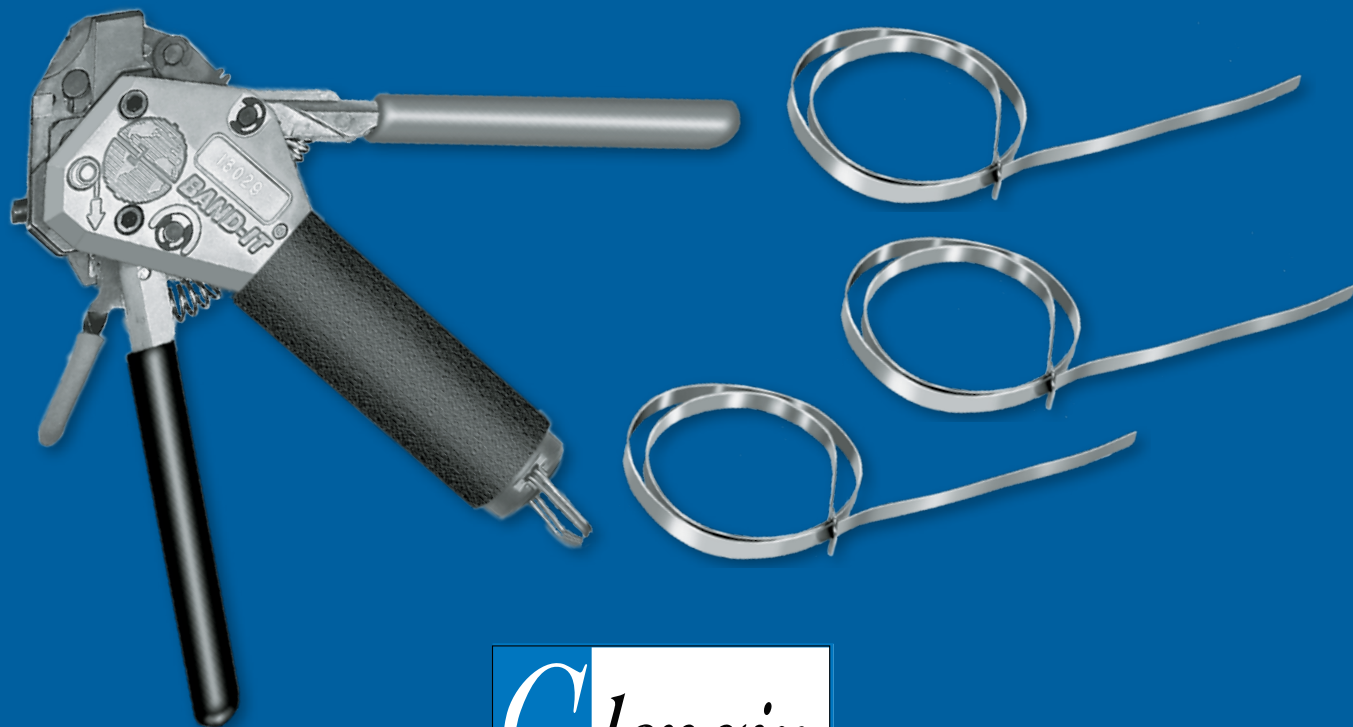

Glencair®

Chapter A: SAE-AS39029 Crimp Contacts Part Number Index



Military Part Number	Glenair Part Number	Contact Size	Wire Accommodation	Pin / Socket	BIN Color Striping			Product Page
M39029/56-348	850-001-22-348	22	22-28 AWG	Socket	Orange	Yellow	Grey	A-6
M39029/56-351	850-001-20-351	20	20-24 AWG	Socket	Orange	Green	Brown	
M39029/56-352	850-001-16-352	16	16-20 AWG	Socket	Orange	Green	Red	
M39029/56-353	850-001-12-353	12	12-14 AWG	Socket	Orange	Green	Orange	
M39029/56-527	850-001-10-527	10	10 AWG	Socket	Green	Red	Violet	
M39029/57-354	850-003-22-354	22	22-28 AWG	Socket	Orange	Green	Yellow	A-8
M39029/57-357	850-003-20-357	20	20-24 AWG	Socket	Orange	Green	Violet	
M39029/57-358	850-003-16-358	16	16-20 AWG	Socket	Orange	Green	Grey	
M39029/57-359	850-003-12-359	12	12-14 AWG	Socket	Orange	Green	White	
M39029/58-360	850-002-22-360	22	22-28 AWG	Pin	Orange	Blue	Black	A-10
M39029/58-363	850-002-20-363	20	20-24 AWG	Pin	Orange	Blue	Orange	
M39029/58-364	850-002-16-364	16	16-20 AWG	Pin	Orange	Blue	Yellow	
M39029/58-365	850-002-12-365	12	12-14 AWG	Pin	Orange	Blue	Green	
M39029/58-528	850-002-10-528	10	10 AWG	Pin	Green	Red	Grey	
M39029/63-368	850-021-20-368	20	20-24 AWG	Socket	Orange	Blue	Grey	A-12
M39029/64-369	850-022-20-369	20	20-24 AWG	Pin	Orange	Blue	White	A-13
M39029/83-450	850-004-20-450	20	22-26 AWG	Pin	Yellow	Green	Black	A-14
M39029/83-451	850-004-20-451	20	28-32 AWG	Pin	Yellow	Green	Brown	
M39029/83-508	850-004-20-508	20	20-24 AWG	Pin	Green	Black	Grey	
M39029/84-452	850-005-20-452	20	22-26 AWG	Socket	Yellow	Green	Red	A-16
M39029/84-453	850-005-20-453	20	28-32 AWG	Socket	Yellow	Green	Orange	
M39029/84-509	850-005-20-509	20	20-24 AWG	Socket	Green	Black	White	
M39029/106-614	850-006-22-614	22	22-28 AWG	Socket	Blue	Brown	Yellow	A-18
M39029/106-615	850-006-20-615	20	20-24 AWG	Socket	Blue	Brown	Green	
M39029/106-616	850-006-16-616	16	16-20 AWG	Socket	Blue	Brown	Blue	
M39029/106-617	850-006-12-617	12	12-14 AWG	Socket	Blue	Brown	Violet	
M39029/106-618	850-006-10-618	10	10 AWG	Socket	Blue	Brown	Grey	
M39029/107-620	850-007-22-620	22	22-28 AWG	Pin	Blue	Red	Black	A-20
M39029/107-621	850-007-20-621	20	20-24 AWG	Pin	Blue	Black	Brown	
M39029/107-622	850-007-16-622	16	16-20 AWG	Pin	Blue	Red	Red	
M39029/107-623	850-007-12-623	12	12-14 AWG	Pin	Blue	Red	Orange	
M39029/107-624	850-007-10-624	10	10 AWG	Pin	Blue	Red	Yellow	



Chapter B: High-Performance Shielded Contacts Part Number Index

Military Part Number	Glenair Part Number	Contact Size	Pin / Socket	Contact Type	BIN Color Striping			Product Page
M39029/27-210	852-001-12-210	12	Socket	Coaxial	Red	Brown	Black	B-4
M39029/27-402	852-001-12-402	12	Socket	Coaxial	Yellow	Black	Red	
M39029/27-403	852-001-12-403	12	Socket	Coaxial	Yellow	Black	Orange	
M39029/27-404	852-001-12-404	12	Socket	Coaxial	Yellow	Black	Yellow	
M39029/27-405	852-001-12-405	12	Socket	Coaxial	Yellow	Black	Green	
M39029/27-406	852-001-12-406	12	Socket	Coaxial	Yellow	Black	Blue	
M39029/27-407	852-001-12-407	12	Socket	Coaxial	Yellow	Black	Violet	
M39029/27-408	852-001-12-408	12	Socket	Coaxial	Yellow	Black	Gray	
M39029/28-211	852-002-12-211	12	Pin	Coaxial	Red	Brown	Brown	B-6
M39029/28-409	852-002-12-409	12	Pin	Coaxial	Yellow	Black	White	
M39029/28-410	852-002-12-410	12	Pin	Coaxial	Yellow	Brown	Black	
M39029/28-411	852-002-12-411	12	Pin	Coaxial	Yellow	Brown	Brown	
M39029/28-412	852-002-12-412	12	Pin	Coaxial	Yellow	Brown	Red	
M39029/28-413	852-002-12-413	12	Pin	Coaxial	Yellow	Brown	Orange	
M39029/28-414	852-002-12-414	12	Pin	Coaxial	Yellow	Brown	Yellow	
M39029/28-415	852-002-12-415	12	Pin	Coaxial	Yellow	Brown	Green	
M39029/59-366	852-006-08-366	08	Socket	Coaxial	Orange	Blue	Blue	B-14
M39029/60-367	852-007-08-367	08	Pin	Coaxial	Orange	Blue	Violet	B-15
M39029/75-416	852-003-12-416	12	Socket	Coaxial	Yellow	Brown	Blue	B-8
M39029/75-417	852-003-12-417	12	Socket	Coaxial	Yellow	Brown	Violet	
M39029/75-418	852-003-12-418	12	Socket	Coaxial	Yellow	Brown	Gray	
M39029/75-419	852-003-12-419	12	Socket	Coaxial	Yellow	Brown	White	
M39029/75-420	852-003-12-420	12	Socket	Coaxial	Yellow	Red	Black	
M39029/75-421	852-003-12-421	12	Socket	Coaxial	Yellow	Red	Brown	
M39029/75-422	852-003-12-422	12	Socket	Coaxial	Yellow	Red	Red	
M39029/75-423	852-003-12-423	12	Socket	Coaxial	Yellow	Red	Orange	
M39029/76-424	852-008-16-424	16	Pin	Coaxial	Yellow	Red	Yellow	B-16
M39029/76-425	852-008-16-425	16	Pin	Coaxial	Yellow	Red	Green	

Chapter B: High-Performance Shielded Contacts Part Number Index



Military Part Number	Glenair Part Number	Contact Size	Pin / Socket	Contact Type	BIN Color Striping			Product Page
M39029/76-426	852-008-16-426	16	Pin	Coaxial	Yellow	Red	Blue	B-16
M39029/76-427	852-008-16-427	16	Pin	Coaxial	Yellow	Red	Violet	
M39029/77-428	852-009-16-428	16	Socket	Coaxial	Yellow	Red	Gray	B-18
M39029/77-429	852-009-16-429	16	Socket	Coaxial	Yellow	Red	White	
M39029/77-430	852-009-16-430	16	Socket	Coaxial	Yellow	Orange	Black	
M39029/77-431	852-009-16-431	16	Socket	Coaxial	Yellow	Orange	Brown	
M39029/78-432	852-010-16-432	16	Socket	Coaxial	Yellow	Orange	Red	
M39029/78-433	852-010-16-433	16	Socket	Coaxial	Yellow	Orange	Orange	B-20
M39029/78-434	852-010-16-434	16	Socket	Coaxial	Yellow	Orange	Yellow	
M39029/78-435	852-010-16-435	16	Socket	Coaxial	Yellow	Orange	Green	
M39029/90-529	853-001-08-529	8	Pin	Concentric Twinax	Green	Red	White	B-22
M39029/91-530	853-002-08-530	8	Socket	Concentric Twinax	Green	Orange	Black	B-23
M39029/102-558	852-004-12-558	12	Pin	Coaxial	Green	Green	Gray	B-10
M39029/103-559	852-005-12-559	12	Socket	Coaxial	Green	Green	White	B-12
M39029/113-625	853-003-08-625	8	Pin	Concentric Twinax	Blue	Red	Green	B-24
M39029/113-626	853-003-08-626	8	Pin	Concentric Twinax	Blue	Red	Blue	
M39029/114-628	853-004-08-628	8	Socket	Concentric Twinax	Blue	Red	Gray	B-25
M39029/114-629	853-004-08-629	8	Socket	Concentric Twinax	Blue	Red	White	
N/A	854-001-01	8	Pin	Quadrax	N/A	N/A	N/A	B-26
	854-001-02	8	Pin	Quadrax				
	854-001-03	8	Pin	Quadrax				
	854-001-04	8	Pin	Quadrax				
	854-001-05	8	Pin	Quadrax				
	854-002-01	8	Socket	Quadrax				B-27
	854-002-02	8	Socket	Quadrax				
	854-002-03	8	Socket	Quadrax				
	854-002-04	8	Socket	Quadrax				
	854-002-05	8	Socket	Quadrax				



Chapter C: Fiber Optic Termini Part Number Index

Glenair Part Number	Part Description	Contact Size	Pin / Socket	Connector Series	Product Page
MIL-DTL-38999 Fiber Optic Contacts					
181-001	M29504/5 Socket Terminus	16	Socket	D38999 Series III	C-4
181-002	M29504/4 Pin Terminus	16	Pin	D38999 Series III	C-6
181-035	Socket, Large Core Fiber	16	Socket	D38999 Series III	C-8
181-036	Pin, Large Core Fiber	16	Pin	D38999 Series III	C-9
181-052	Jewel Pin Terminus	16	Pin	D38999 Series III	C-10
181-053	Jewel Socket Terminus	16	Socket	D38999 Series III	C-11
181-048	Sealing Plug	16	Pin	D38999 Series III	C-12
181-065	#20 Pin Terminus	20	Pin	D38999 Series III	C-13
181-066	#20 Socket Terminus	20	Socket	D38999 Series III	C-14
MIL-PRF-28876 Fiber Optic Contacts					
181-039	M29504/14 Pin Terminus	16	Pin	M28876	C-15
181-040	M29504/15 Socket Terminus	16	Socket	M28876	C-16
181-051	M29504/3 Dummy Terminus	16	Dummy	M28876	C-33
Series 80 Mighty Mouse Fiber Optic Contacts					
181-057	Mighty Mouse Pin Terminus	16	Pin	Series 80 Mighty Mouse	C-18
181-075	Mighty Mouse Socket Terminus	16	Socket	Series 80 Mighty Mouse	C-19
Special Fiber Optic COTS Contacts Size 16 Front Release					
181-011	Front Release Socket with Pressure Sealing O-Ring(s)	16	Socket	COTS	C-20
181-012	Front Release Pin	16	Pin	COTS	C-22
181-051	M29504/3 Dummy Terminus	16	Dummy	COTS	C-33
ARINC Type Fiber Optic Contacts					
181-076	ARINC 801 Terminus	16	Genderless Pin	ARINC 801	C-24
187-079	M29504/6 Pin Terminus	16	Pin	ARINC 404, 600	C-25
187-080	M29504/7 Socket Terminus	16	Socket	ARINC 404, 600	C-26
Glenair High Density (GHD) Fiber Optic Contacts					
181-056	GHD Terminus, Non-keyed	18	Genderless Pin	GHD	C-28
181-047	GHD Terminus, Keyed	18	Genderless Pin	GHD	C-30
181-058	Dummy Terminus	18	Dummy	GHD	C-32
Glenair GFOCA Fiber Optic Contacts					
181-050	GFOCA Terminus		Genderless Pin	GFOCA	C-34
181-059	Dummy Terminus		Dummy	GFOCA	C-36
Next Generation Fiber Optic (NGCON) Contacts					
181-043	M29504/18	16	Genderless Pin	M64266	C-37

Chapter D: Special Purpose Contacts Part Number Index



Glenair Part Number	Part Description	Contact Size	Type	Product Page
859-xxx	Grommet Sealing Plugs (MS27488 Type)	0-23	Sealing Plug	D-3
809-001	Series 80 Mighty Mouse Pin Contact	23	Crimp Contact	D-4
809-002	Series 80 Mighty Mouse Socket Contact	23	Crimp Contact	D-5
857-010	Pneumatic Socket Contact for Series 79	12	Pneumatic	D-6
857-011	Pneumatic Pin Contact for Series 79	12	Pneumatic	D-7
850-010	PCB Pin Contact to fit D38999/20 and /24	12-22	PCB Pin	D-8
850-011	PCB Socket Contact to fit D38999/20 and /24	12-22	PCB Socket	D-9
850-013	High Power Socket Contact	8	Power Socket	D-10
850-014	High Power Pin Contact	8	Power pin	D-11
850-015	M39029/56 Type Socket Contact with Solder Cup	10-22	Solder Cup	D-12
850-016	Pin Contact with Solder Cup	10-22	Solder Cup	D-14
850-017	M39029/58 Type Pin Contact with Solder Cup	12-22	Solder Cup	D-16
850-018	M39029/56-348 Type Socket Contact	22	Crimp Contact	D-18
850-019	M39029/58-360 Type Pin Contact	22	Crimp Contact	D-19
850-020	M39029/57 Type Socket Contact	22	Crimp Contact	D-20
857-027	M39029/58 Type High Power Pin with PC Tails	8	PCB Power	D-21
857-028	M39029/56 Type High Power Socket with PC Tails	8	PCB Power	D-22
687-348	Wire to Contact Crimp Adapter		Crimp Adapter	D-23
850-023	M39029/87 Thermocouple Pin Contact	16, 20, 22	Thermocouple	D-24
850-024	M39029/88 Thermocouple Socket Contact; Series I, II, IV	16, 20, 22	Thermocouple	D-26
850-025	M39029/89 Thermocouple Socket Contact; Series II	16, 20, 22	Thermocouple	D-28



Chapter E: Tools and Accessories Part Number Index

Glenair Part Number	Military Part Number	Part Description	Product Page
Miniature Adjustable Crimp Tools			
809-015	M22520/2-01	Standard miniature hand crimp tool	E-2
809-128	N/A	Special miniature hand crimp tool for use with 50ohm matched impedance contacts	
Positioners For Use With M22520/2 Miniature Adjustable Crimp Tool			
809-005	N/A	Size #23 contacts for #22-#28 AWG wire	E-2
809-057	N/A	Small bore #23 for #26-#30 AWG wire	
809-125	M22520/2-35	M39029/76 and /78 coax inner contact	
809-124	N/A	Matched impedance #12 coax inner contact	
809-135	M22520/2-34	M39029/27 and /28 coax inner contact	
859-006	N/A	Matched impedance #12 coax inner contact. (Use with 809-128 crimp tool)	
809-206	N/A	#20HD contacts	
N/A	M22520/2-10	#20 contact, series I, II, III and IV	
N/A	M22520/2-09	#22D contact, series I, II, III and IV Pin	
N/A	M22520/2-07	#22D contact, series I, III and IV Socket	
N/A	M22520/2-06	#22D contact, series II Socket	
N/A	M22520/2-35	#16 contact, series I, II, III and IV	
N/A	M22520/2-34	#12 contact, series I, II, III and IV	
N/A	M22520/2-37	Quadrax Inner Contact	
Crimp Tool And Positioner For #12, #16 And #20 Power Contacts			
809-136	M22520/1-01	Crimp tool for use with size #20, #16 and #12 power pins	E-3
809-137	M22520/1-04	Positioner for use with size #20, #12 and #16 Power contacts	
809-138	N/A	Positioner for use with 809-093 adapters	
Crimp Tool And Positioner For #16 Coaxial Outer Contact			
809-127	M22520/4-01	Crimp tool for use with size #16 coaxial contacts.	E-3
809-126	M22520/4-02	Positioner for use with size #16 coaxial contacts	

Chapter E: Tools and Accessories Part Number Index



Glenair Part Number	Military Part Number	Part Description	Product Page
Crimp Tool And Positioner For #12 Coaxial Outer Contact			
809-133	M22520/31-01	Crimp tool for use with size #12 coaxial contacts.	E-3
809-134	M22520/31-02	Positioner for use with size #12 coaxial contacts	
Parallel Action Crimp Tool And Hex Die Set For 50 Ohm Matched Impedance #12 Contacts			
809-129	M22520/5-01	Parallel action tool for use with hex crimp dies	E-3
809-130	M22520/5-03	Die set for terminating coaxial shield to outer contact	
Contact Insertion and Extraction Tools			
809-088	N/A	#23 Insertion/Extraction	E-4
809-013	N/A	#23 Insertion Only	
809-203	N/A	#20HD Insertion/Extraction	
809-131	M81969/14-03	#16 Insertion/Extraction	
809-132	M81969/14-04	#12 Insertion/extraction	
809-207	M81969/14-10	#20 Insertion/extraction	
Contact Retention Tester For #23 Contacts			
809-107-1	N/A	Tester Handle	E-4
809-107-2	N/A	Pin Tip	
809-107-3	N/A	Socket Tip	
809-107-4	N/A	Complete Kit	
Fiber Optic Assembly Tools			
182-012	N/A	Fiber optic terminus crimping tool	E-5
182-013	N/A	Straight insertion tool for fiber optic termini	E-6
182-014	N/A	Right angle 90° insertion tool for fiber optic termini	E-7
182-015	N/A	Extraction tool for fiber optic termini	E-8
182-016	N/A	Alignment sleeve insertion/extraction tool for fiber optic termini	E-9

WHY CHOOSE GLENAIR?



Plenty of Raw Materials!



Outstanding
Customer Service!



Abundant Machining Capacity!



In-House Assembly!



Huge "Same-Day" Inventory!

Glenair®



A World of Interconnect Solutions

Glenair, Inc.

1211 Air Way • Glendale, California • 91201-2497

Telephone: 818-247-6000 • Fax: 818-500-9912 • sales@glenair.com

www.glenair.com

Glenair Power Products Group

860 N. Main Street Extension
Wallingford, CT
06492

Telephone:
203-741-1115
Facsimile:
203-741-0053
sales@glenair.com

Glenair UK Ltd

40 Lower Oakham Way
Oakham Business Park
P.O. Box 37, Mansfield
Notts, NG18 5BY England

Telephone:
44-1623-638100
Facsimile:
44-1623-638111
sales@glenair.co.uk

Glenair Microway Systems

7000 North Lawndale Avenue
Lincolnwood, IL
60712

Telephone:
847-679-8833
Facsimile:
847-679-8849

Glenair Nordic AB

Gustav III : S Boulevard 46
S - 169 27 Solna
Sweden

Telephone:
46-8-50550000
Facsimile:
46-8-50550001
sales@glenair.se

Glenair Electric GmbH

Siemensstrasse 9
D-61449 Steinbach
Germany

Telephone:
49-6171-5905-0
Facsimile:
49-6171-5905-90
germany@glenair.com

Glenair Iberica

C/ La Vega, 16
45612 Velada
Spain

Telephone:
34-925-89-29-88
Facsimile:
34-925-89-29-87
sales@glenair.es

Glenair Italia S.R.L.

Via Santi, 1
20037 Paderno Dugnano
Milano, Italy

Telephone:
39-02-9108-2121
Facsimile:
39-02-9904-3565
sales-italia@glenair.it

Glenair France SARL

7, Avenue Parmentier
Immeuble Central Parc #2
31200 Toulouse
France

Telephone:
33-5-34-40-97-40
Facsimile:
33-5-61-47-86-10
sales@glenair.fr

Held Hostage to Long Lead Times?
Need a Contact Now?
M39029 Contacts In Stock!

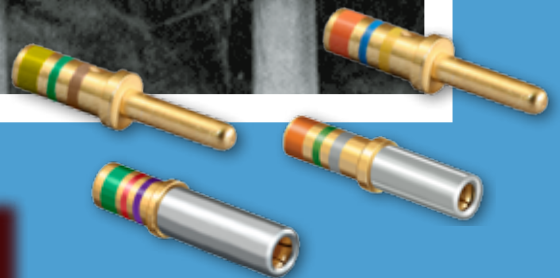

1211 Air Way
Glendale, California 91201-2497

Telephone: 818-247-6000 · Facsimile: 818-500-9912 · E-mail: sales@glenair.com

United States · United Kingdom · Germany · Nordic · France · Italy · Spain · Japan

www.glenair.com



SERIES 85

RF, MICROWAVE AND DATALINK CONTACTS

**for MIL-DTL-38999, Series 23 SuperNine®, Series 80 Mighty Mouse,
and Series 79 Micro-Crimp® connectors**



High Speed High Reliability High Availability

No more long lead times —
Glenair high-performance RF,
microwave and datalink contacts are
in stock and ready to ship

Glenair's growing portfolio of high-speed solutions now includes a wide selection of RF, microwave and datalink contacts. Compatible with MIL-DTL-38999 connectors, these contacts also fit Glenair Series 80 Mighty Mouse, Series 79 Micro-Crimp® and Series 23 SuperNine® connectors. Designed in accordance with SAE AS39029 requirements, these contacts are suitable for aerospace and defense equipment subjected to high-vibration and temperature extremes.

Glenair's complete high-speed solution also includes a wide variety of standard and modified connectors, cordsets, fiber optic and opto-electronic technologies. Our rapid-response engineering and manufacturing capabilities allow us to quickly design and build customized interconnects and systems.

- 50 and 75 ohm coax contacts
- Spring-loaded microwave contacts
- Twinax contacts
- Quadrax contacts
- El Ochito® octaxial contacts

CUSTOM PACKAGING—OUR SPECIALTY



El Ochito® 10GBase-T Ethernet contacts installed in a custom Micro-Crimp connector

Quadrax contacts installed in a HiPer-D connector



Custom right angle board mount twinax connector

RF, Microwave and Datalink Contacts

for MIL-DTL-38999, SuperNine®, Mighty Mouse, and
Micro-Crimp Connectors



Table of Contents

Product Selection Guide	2
AS39029 Coaxial Contacts	
Size #8 AS39029 Coaxial Contacts <i>852-006, 852-007, M39029/59, M39029/60</i>	6
Size #12 AS39029 Coaxial Contacts <i>852-001, -002, -003, -004, -005 M39029/27, /28, /102, /103</i>	7
Size #16 AS39029 Coaxial Contacts <i>852-008, 852-009, 852-010, M39029/76, /77, /78</i>	8
Low-Loss Matched-Impedance Contacts	
Selection Guide	9
Size #8 50 Ohm Matched-Impedance Contacts <i>852-030, 852-031, 852-042, 852-043</i>	10
Size #12 50 Ohm Matched-Impedance Contacts <i>852-015, -016, -017, -018, -019, -037</i>	12
Size #8 75 Ohm Matched-Impedance Contacts <i>852-056, 852-057, 852-082, 852-083</i>	14
Size #12 75 Ohm Matched-Impedance Contacts <i>852-103, 852-104, 852-106</i>	16
High Performance 75 Ohm Coaxial Cable <i>960-130, 960-131, 960-132</i>	18
Spring-Loaded Microwave Coaxial Contacts	
Size #8 BMB Style Spring-Loaded 18 GHz Contacts <i>852-070, 852-071</i>	22
Size #12 SMPM Style Spring-Loaded 40 GHz Contacts <i>852-024, 852-025, 852-032</i>	24
Twinax Contacts	
Size #8 AS39029 Concentric Twinax Contacts <i>853-003, -004, M39029/113, /114</i>	26
Size #8 100 Ohm Concentric Twinax Contacts <i>853-011, 853-012</i>	28
Size #12 Concentric Twinax Contacts <i>853-008, 853-009</i>	30
Size #8 100 Ohm Differential Twinax Contacts <i>853-013, 853-014, 853-024, 853-025</i>	32
Size #12 100 Ohm Differential Ultra-Twinax Contacts <i>853-015, 853-016</i>	35
Quadrax Contacts	
Size #8 100 Ohm and 150 Ohm Quadrax Contacts <i>854-001, 854-002, 854-014, 854-015</i>	37
Aerospace-Grade Star Quad Cable	39
El Ochito® Octaxial Contacts for Gigabit and 10G Ethernet	
Size #8 El Ochito® Contacts <i>858-003, 858-004, 858-009, 858-010, 858-016, 858-017</i>	40
Aerospace-Grade Category 6a Ethernet Cable <i>963-003, 963-033</i>	46
Pre-Wired El Ochito® Contacts <i>858-022</i>	47
El Ochito® Test Adapters and Jumpers <i>858-020, 859-117, -118, -132, -133</i>	49
Part Number Index	51

RF, Microwave and Datalink Contacts

for MIL-DTL-38999, SuperNine®, Mighty Mouse, and Micro-Crimp Connectors



Product Selection Guide

AS39029 RF Contacts



Size #8 AS39029 Coaxial Contacts for RG-180..... 6 *dc – 700 MHz*

Size #8 coaxial contacts accept RG-180 cable. Maximum frequency is 700 MHz. Crimp termination. Snap-in, rear release. Compatible with MIL-DTL-38999 Series I, III, and IV, Series 23 SuperNine, and Series 80 Mighty Mouse connectors with size 8 cavities. AS39029 qualified.



Size #12 AS39029 Coaxial Contacts 7 *dc – 3 GHz*

Size #12 coaxial contacts accept RG-174, RG-179, RG-180 and RG-316 cable. Crimp termination. Snap-in, rear release. Compatible with MIL-DTL-38999 Series I, II, III, and IV, Series 23 SuperNine, Series 79 MicroCrimp and Series 80 Mighty Mouse connectors with size 12 cavities. AS39029 qualified.



Size #16 AS39029 Coaxial Contacts 8 *dc – 500 MHz*

Size #16 coaxial contacts accept RG-174, RG-178, RG-179 and RG-316 cable. Crimp termination. Snap-in, rear release. Compatible with MIL-DTL-38999 Series I, II, III, and IV, Series 23 SuperNine, Series 79 MicroCrimp and Series 80 Mighty Mouse connectors with size 16 cavities. AS39029 qualified.

50 Ohm Low-Loss Matched-Impedance Coaxial Contacts



Size #8 50 Ohm Matched-Impedance Contacts..... 10 *dc – 6 GHz*

High-frequency matched-impedance #8 contacts accept RG-316 single and double shielded cable along with M17/220-0001 cable. Compatible with MIL-DTL-38999, Series 23 SuperNine and Series 80 Mighty Mouse connectors. Crimp termination. Snap-in, rear-release. 50 ohm impedance.



Size #12 50 Ohm Matched-Impedance Contacts 12 *dc – 3 GHz*

High-frequency matched-impedance contacts accept RG-178, RG-316, and RG-405 flex cable. Compatible with MIL-DTL-38999 Series I, II, III and IV, Series 23 SuperNine, Series 79 MicroCrimp and Series 80 Mighty Mouse connectors. Crimp termination. Snap-in, rear-release. 50 ohm impedance.

RF, Microwave and Datalink Contacts

for MIL-DTL-38999, SuperNine®, Mighty Mouse, and Micro-Crimp Connectors



Product Selection Guide

75 Ohm Low-Loss Matched-Impedance Coaxial Contacts



Size #8 75 Ohm Matched-Impedance Contacts 14 *dc – 4 GHz*

High-frequency 75 ohm #8 contacts accept RG-179 cable along with high performance RS170, SMPTE 292M, SMPTE 424M and other video cables. Compatible with MIL-DTL-38999 Series I, III, and IV, Series 23 SuperNine and Series 80 Mighty Mouse connectors. Crimp termination. Snap-in, rear-release.



Size #12 75 Ohm Matched-Impedance Contacts 16 *dc – 3 GHz*

75 ohm size #12 matched-impedance contacts accept high performance RS170, SMPTE 292M and other video cables. Compatible with MIL-DTL-38999 Series I, II, III, and IV, Series 23 SuperNine, Series 79 MicroCrimp and Series 80 Mighty Mouse connectors. Crimp termination. Snap-in, rear-release.



75 Ohm High-Performance Video Cable 18

Cable is specially designed and manufactured for reliable performance in aircraft systems and other harsh environments involving high temperature, EMI and corrosive materials.

50 Ohm Spring-Loaded Microwave Coaxial Contacts



Size #8 Spring-Loaded BMB Coaxial Contacts 22 *dc – 18 GHz*

These size 8 contacts conform to the MIL-STD-348 BMB interface standard. These contacts accept RG-402-FLEX and RG-405-FLEX cables along with other low loss flexible cables. Compatible with MIL-DTL-38999 Series I, III, and IV, Series 23 SuperNine and Series 80 Mighty Mouse connectors. Solder termination.



Size 12 Spring-Loaded SMPM Coaxial Contacts 24 *dc – 40 GHz*

These size 12 contacts accept RG-405-FLEX cable and are compatible with MIL-DTL-38999, Series 23 SuperNine, Series 79 MicroCrimp and Series 80 Mighty Mouse connectors. Solder termination. .

RF, Microwave and Datalink Contacts

for MIL-DTL-38999, SuperNine®, Mighty Mouse, and Micro-Crimp Connectors



Product Selection Guide

Twinax Contacts



Size #8 77 Ohm Concentric Twinax Contacts 26

M39029 concentric twinax contacts accommodate 77 ohm shielded twisted pair cable. These size 8 contacts meet the requirements of M39029/113 and /114. Compatible with MIL-DTL-38999, Series 23 SuperNine and Series 80 Mighty Mouse connectors. Use with M17/176-00002 databus cable, 10 MHz maximum operating frequency.



Size #8 100 Ohm Concentric Twinax Contacts 28

These concentric twinax contacts accommodate 24 AWG 100 ohm shielded twisted pair data cable. Compatible with MIL-DTL-38999 Series I, III, and IV, Series 23 SuperNine and Series 80 Mighty Mouse connectors. Accepts TE/Raychem 0024A0024 and Gore GSC-03-81416-00 cables.



Size #12 77 Ohm Concentric Twinax Contacts 30

M39029 concentric twinax contacts accommodate 77 ohm shielded twisted pair data cable. Typically used for MIL-STD-1553 databus applications, these size 12 contacts meet the requirements of JN1104, DSCC 02003 and DSCC 02004. Compatible with MIL-DTL-38999 Series I, III, and IV connectors. Snap-in, rear release, crimp termination.



Size #8 Differential Twinax Contacts 32

Rated for dc – 3 GHz frequency, these contacts accept 68, 75, 77 and 100 ohm shielded twisted pair cable including with M17/176-00002 databus cable. Compatible with Series 80 Mighty Mouse connectors and Glenair 233-217 MIL-DTL-38999-type Series III connectors with keyed #8 cavities. **Not for use in standard MIL-DTL-38999 connectors with unkeyed inserts.**



Size #12 Differential Ultra-Twinax Contacts 35

These 100 Ohm differential twinax contacts are suited for multi-gigabit data rate applications such as CML, LVDS and other advanced digital communications protocols. Use with high-speed #30 AWG twisted pair cable. These contacts are compatible with Glenair Series 80 Mighty Mouse connectors with size #12 cavities. Size #12 100 ohm contacts feature DC – 10 GHz frequency range. Solder termination.

RF, Microwave and Datalink Contacts

for MIL-DTL-38999, SuperNine®, Mighty Mouse, and Micro-Crimp Connectors



Product Selection Guide

Quadrax Contacts



Quadrax Contacts 37

100 ohm Ethernet and 150 ohm Fibre Channel differential quadrax contacts are compatible with standard Series 80 Mighty Mouse connectors and Glenair 233-217 MIL-DTL-38999-type Series III connectors with keyed #8 inserts. These contacts accept aerospace grade quad cable.

Not for use with standard MIL-DTL-38999 connectors with unkeyed inserts.

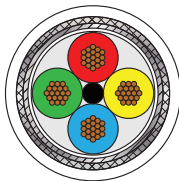

Quad Cable..... 39

Aerospace-grade four-conductor 100 ohm quad cable is available in wire sizes 22, 24 and 26. These high-performance cables feature inner and outer shields for excellent EMI protection. High-temperature fluoropolymer insulation provides up to 150°C or 200°C temperature rating.

El Ochito® Octaxial Contacts



El Ochito® Octaxial Contacts 40

El Ochito, “the Little 8”, brings 1000BASE-T and 10GBASE-T capability to a size #8 snap-in contact with eight inner contacts. Data pair isolation technology reduces crosstalk between pairs. This contact accepts flight-grade Cat6a cable with #26AWG conductors.

Not for use with standard MIL-DTL-38999 connectors with unkeyed inserts.

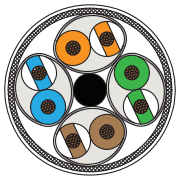

Aerospace Cat6a Cable..... 46

Lightweight, shielded flight-grade Ethernet cable is available in two styles: S/UTP (unshielded pairs) and S/FTP (foil-wrapped pairs). These 26 AWG cables are 200°C rated and meet ANSI/TIA 568-C.2 Category 6a requirements.



Pre-Wired El Ochito® Contacts 47

Pre-wired El Ochito® assemblies are 100% tested and ready for use. These assemblies are available with three termination options: single-ended, El Ochito® contacts on both ends, or with an RJ45 plug on one end.

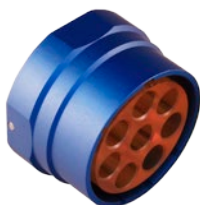

El Ochito® Test Adapters and Jumpers 49

Prevent damage to expensive cables with El Ochito® test adapters and jumper cables. These test adapters properly align mating test contacts without the added expense and time-consuming labor of mating connectors. Jumper cables have shielded Cat6a RJ45 plugs.

RF, Microwave and Datalink Contacts

for MIL-DTL-38999, SuperNine[®], Mighty Mouse and Micro-Crimp[®] Connectors



AS39029 Coaxial Contacts

Size #8 AS39029 Coaxial Contacts



These snap-in, rear-release contacts fit Glenair Series 80 Mighty Mouse, Series 23 SuperNine[®], and MIL-DTL-38999 Series I, III and IV connectors with size #8 cavities. Crimp termination. SAE AS39029 qualified. Shipped unassembled with assembly instruction sheet, expander tool and push-rod tool.

Technical Data	
Specifications	Construction
Operating temperature: -65°C to +200°C Dielectric withstanding voltage: 1300 Vac rms at sea level, 250 Vac at 50,000 feet Current rating: 1 ampere Durability: 500 mating cycles Shock: EIA-364-27 condition D Vibration: MIL-DTL-38999 Max operating frequency: 700 MHz	Inner contact, body, outer sleeve: copper alloy, gold over nickel underplate per AS39029 Type D Insulator: fluoroplastic

Size #8 AS39029 Coaxial Contacts								
RG Cable	Size	Pin Contact M38999 Series I, III, IV Series 80	Socket Contact M38999 Series I, III, IV Series 80	Crimp Tools				Removal Tool
				Inner Contact Crimper	Positioner	Shield Crimp Sleeve Crimper	Die Set	
RG180	8	852-007-08-367 (M39029/60-367)	852-006-08-366 (M39029/59-366)	809-015 (M22520/2-01)	859-050 (M22520/2-31)	809-129 (M22520/5-01)	859-051 (M22520/5-05)	859-022 (M81969/14-06)

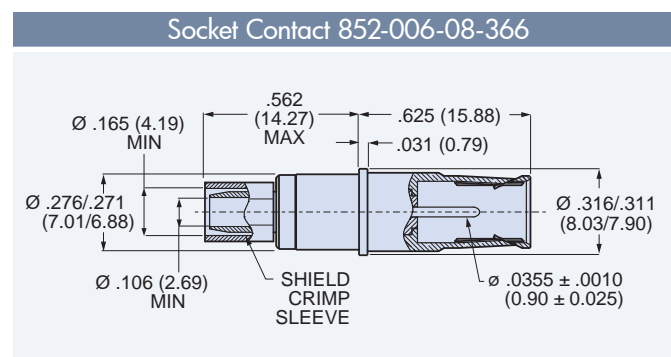
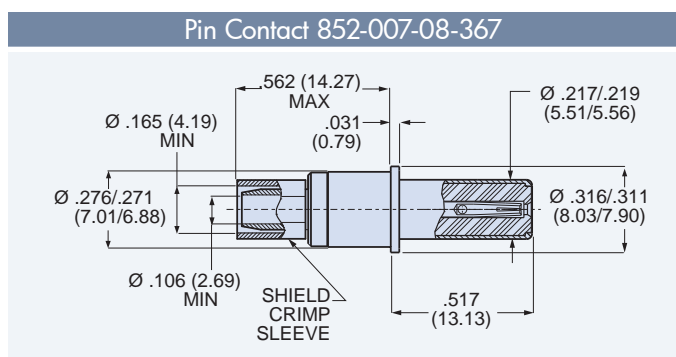

#8 Sealing Boot

Optional sealing boot fits RG180 cable. Slide boot onto cable before terminating contact. Fluorosilicone grommet, Ultem follower.

Technical drawing of #8 Sealing Boot. Dimensions include: overall length .985 (25.02) MAX, outer diameter .350 (8.89), and inner diameter .326 (8.28).

Cable Range (In.)	Part Number
.130-.170	859-042-02

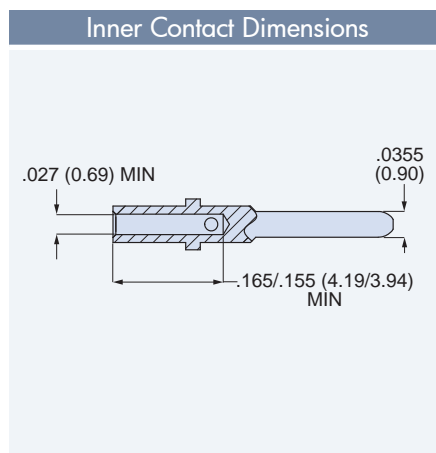

AS39029 Color Stripes

Part Number	AS39029 Part No.	Color Bands		
		1st	2nd	3rd
852-006-08-366	M39029/59-366	ORANGE	BLUE	BLUE
852-007-08-367	M39029/60-367	ORANGE	BLUE	VIOLET

RF, Microwave and Datalink Contacts

for MIL-DTL-38999, SuperNine®, Mighty Mouse and Micro-Crimp® Connectors



AS39029 Coaxial Contacts

Size #12 AS39029 Coaxial Contacts



These snap-in, rear-release contacts fit Glenair Series 80 Mighty Mouse, Series 23 SuperNine®, Series 79 Micro-Crimp® and MIL-DTL-38999 connectors with size #12 cavities. Crimp termination. SAE AS39029 qualified.

Technical Data	
Specifications	Construction
<ul style="list-style-type: none"> Operating temperature: -65°C. to +200°C. Dielectric withstanding voltage: 1000 Vac rms at sea level, 250 Vac at 50,000 feet Current rating: 1 ampere Durability: 500 mating cycles 50 ohm nominal impedance* VSWR: 1.32 max., 500 MHz to 3 GHz* Insertion loss: 0.20 dB max. @ 3 GHz* 	<ul style="list-style-type: none"> Inner contact, body, outer sleeve: copper alloy, gold over nickel underplate per AS39029 Type D Socket contact hood: stainless steel Insulator: fluoroplastic
* Applies to 852-004 and 852-005 only	

Size #12 AS39029 Coaxial Contacts

RG Cable	Size	Freq.	Pin Contact M38999 I-IV Ser. 79, 80	Socket Contact		Crimp Tools				Insertion/ Removal Tool
				M38999 Series I, III, IV	M38999 Ser. II Series 79, 80	Inner Contact Crimper	Positioner	Shield Crimp Sleeve Crimper	Die Set	
RG174	12	700 MHz	852-002-12-211 (M39029/28-211)	852-003-12-416 (M39029/75-416)	852-001-12-210 (M39029/27-210)	809-015 (M22520/2-01)	809-135 (M22520/2-34)	809-133 (M22520/31-01)	809-134 (M22520/31-02)	809-132 (M81969/14-04)
RG179	12	200 MHz	852-002-12-211 (M39029/28-211)	852-003-12-416 (M39029/75-416)	852-001-12-210 (M39029/27-210)	809-015 (M22520/2-01)	809-135 (M22520/2-34)	809-133 (M22520/31-01)	809-134 (M22520/31-02)	809-132 (M81969/14-04)
RG180	12	700 MHz	852-002-12-409 (M39029/28-409)	852-003-12-417 (M39029/75-417)	852-001-12-402 (M39029/27-402)	809-015 (M22520/2-01)	809-135 (M22520/2-34)	809-133 (M22520/31-01)	809-134 (M22520/31-02)	809-132 (M81969/14-04)
RG316	12	700 MHz	852-002-12-211 (M39029/28-211)	852-003-12-416 (M39029/75-416)	852-001-12-210 (M39029/27-210)	809-015 (M22520/2-01)	809-135 (M22520/2-34)	809-133 (M22520/31-01)	809-134 (M22520/31-02)	809-132 (M81969/14-04)
		3 GHz	852-004-12-558 (M39029/102-558)	852-005-12-559 (M39029/103-559)	(N/A)	809-128 (MH992)	859-006 (K1721)	809-129 (M22520/5-01)	809-130 (M22520/5-03)	809-132 (M81969/14-04)

Pin Contact 852-002, 852-004

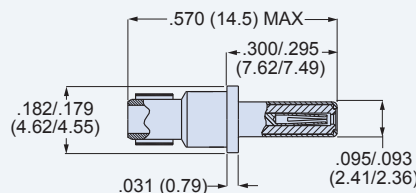

Socket Contact 852-001

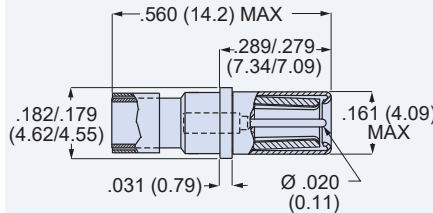

Cable Entry

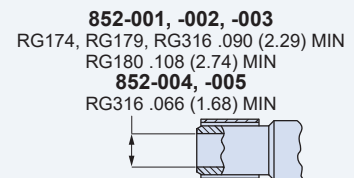

Socket Contact 852-003, 852-005

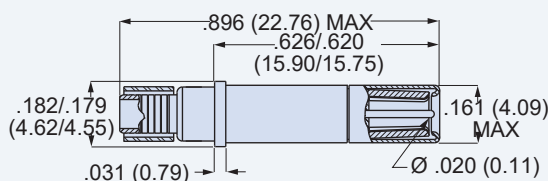

AS39029 Color Stripes

AS39029 Part No.	Color Bands		
	1st	2nd	3rd
M39029/27-210	RED	BROWN	BLACK
M39029/27-402	YELLOW	BLACK	RED
M39029/28-211	RED	BROWN	BROWN
M39029/28-409	YELLOW	BLACK	WHITE
M39029/75-416	YELLOW	BROWN	BLUE
M39029/75-417	YELLOW	BROWN	VIOLET
M39029/102-558	GREEN	GREEN	GRAY
M39029/103-559	GREEN	GREEN	WHITE

Inner Contact Crimp Barrel

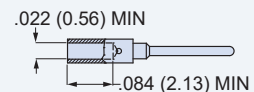

RF, Microwave and Datalink Contacts

for MIL-DTL-38999, SuperNine[®], Mighty Mouse and Micro-Crimp[®] Connectors



AS39029 Coaxial Contacts

Size #16 AS39029 Coaxial Contacts



These snap-in, rear-release contacts fit Glenair Series 80 Mighty Mouse, Series 23 SuperNine[®], Series 79 Micro-Crimp[®] and MIL-DTL-38999 connectors with size #16 cavities. Crimp termination. SAE AS39029 qualified.

Technical Data	
Specifications	Construction
Operating temperature: -65°C. to +200°C. Dielectric withstanding voltage: 800 Vac rms at sea level, 250 Vac at 50,000 feet Current rating: 1 ampere Durability: 500 mating cycles VSWR: 1.50 max. @ 500 MHz	Inner contact, body, outer sleeve: copper alloy, gold over nickel underplate per AS39029 Type D Socket contact hood: stainless steel Insulator: fluoroplastic

Size #16 AS39029 Coaxial Contacts										
RG Cable	Size	Max. Freq.	Pin Contact M38999 I-IV Ser. 79, 80	Socket Contact		Crimp Tools				Insertion/Removal Tool
				M38999 Series I, III, IV	M38999 Ser. II Series 79, 80	Inner Contact Crimper	Positioner	Shield Crimp Sleeve Crimper	Die Set	
RG174 RG179 RG316	16	500 MHz	852-008-16-424 (M39029/76-424)	852-009-16-428 (M39029/77-428)	852-010-16-432 (M39029/78-432)	809-015 (M22520/2-01)	809-125 (M22520/2-35)	809-127 (M22520/4-01)	809-126 (M22520/4-02)	809-131 (M81969/14-03)
RG178	16	500 MHz	852-008-16-425 (M39029/76-425)	852-009-16-429 (M39029/77-429)	852-010-16-433 (M39029/78-433)					

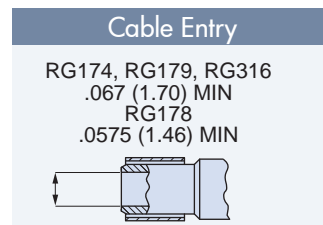
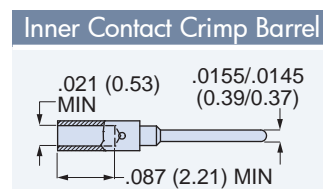
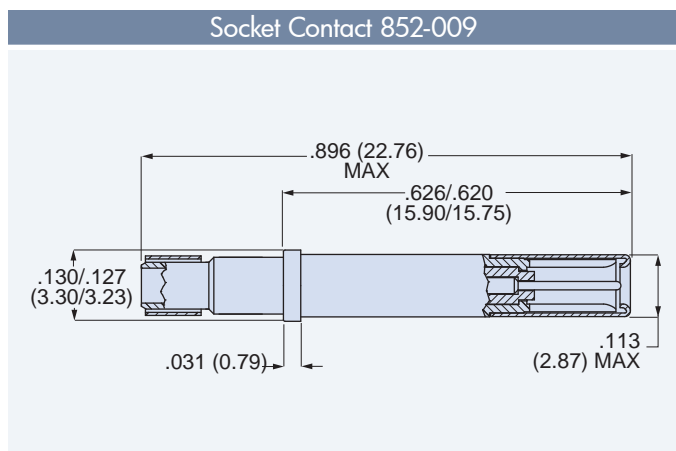
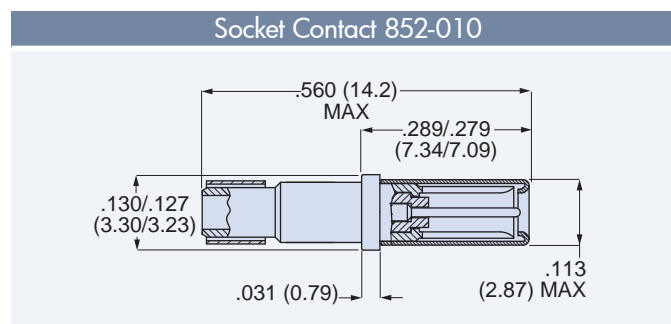
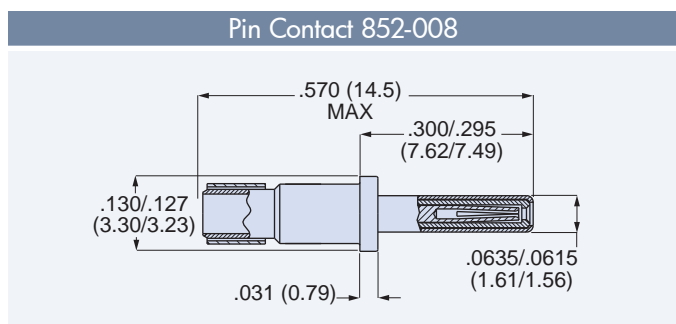

AS39029 Color Stripes

AS39029 Part No.	Color Bands		
	1st	2nd	3rd
M39029/76-424	YELLOW	RED	YELLOW
M39029/76-425	YELLOW	RED	GREEN
M39029/77-428	YELLOW	RED	GRAY
M39029/77-429	YELLOW	RED	WHITE
M39029/78-432	YELLOW	ORANGE	RED
M39029/78-433	YELLOW	ORANGE	ORANGE

RF, Microwave and Datalink Contacts

for MIL-DTL-38999, SuperNine®, Mighty Mouse and Micro-Crimp® Connectors



Low-Loss Matched-Impedance Coaxial Contacts

Selection Guide

50 Ohm Matched-Impedance Contacts

These 50 ohm high frequency contacts provide low insertion loss and improved VSWR compared to AS39029 coaxial contacts. These snap-in, rear-release contacts are compatible with MIL-DTL-38999 connectors and Glenair Series 79 Micro-Crimp®, Series 80 Mighty Mouse and Series 23 SuperNine® connectors.



50 Ohm Matched-Impedance Coaxial Contacts						
Cable	Size	Max. Freq.	Pin Contact M38999 I-IV Ser. 79, 80	Socket Contact		Page
				M38999 Series I, III, IV Series 80	M38999 Series II Series 79, 80	
RG178	12	3 GHz	852-016-03	852-019-03	852-015-03	12
RG316	8	3 GHz	852-031-02F	852-030-02F	(N/A)	10
RG316	12	3 GHz	852-016-01	852-019-01	852-015-01	12
RG316DS	8	6 GHz	852-031-01F	852-030-01F	(N/A)	10
RG316DS	12	3 GHz	852-016-02	852-019-02	852-015-02	12
RG405-FLEX	12	3 GHz	852-018	852-037	852-017	12
M17/220-0001	8	2.5 GHz	852-043F	852-042F	(N/A)	10

75 Ohm Matched-Impedance Contacts

These 75 ohm high frequency contacts for up to 4 GHz frequency range accept aerospace grade digital video cable. These snap-in, rear-release contacts are compatible with MIL-DTL-38999 connectors, Glenair Series 79 Micro-Crimp®, Series 80 Mighty Mouse and Series 23 SuperNine® connectors.



75 Ohm Matched-Impedance Coaxial Contacts						
Cable	Size	Max. Freq.	Pin Contact M38999 I-IV Ser. 79, 80	Socket Contact		Page
				M38999 Series I, III, IV Series 80	M38999 Series II Series 79, 80	
RG179	8	4 GHz	852-056-02F	852-057-02F	(N/A)	14
RG179	12	3 GHz	852-103-02	852-106-02	852-104-02	16
PIC V73263, V75268, V76261	8	4 GHz	852-056-01F	852-057-01F	(N/A)	14
PIC V73263, V75268, V76261	12	4 GHz	852-103-01	852-106-01	852-104-01	16
PIC V78209	8	4 GHz	852-082-01F	852-083-01F	(N/A)	14
LMR-240-75	8	4 GHz	852-082-02F	852-083-02F	(N/A)	14

RF, Microwave and Datalink Contacts

for MIL-DTL-38999, SuperNine®, Mighty Mouse and Micro-Crimp® Connectors



Low-Loss Matched-Impedance Coaxial Contacts

Size #8 50 Ohm Matched-Impedance Coaxial Contacts

Coax contacts fit Glenair Series 80 Mighty Mouse connectors and MIL-DTL-38999 Series I, III and IV connectors with size 8 contact cavities. 50 ohm nominal impedance. DC – 6 GHz frequency range. Inner contact is solder type, shield termination is crimp type. Supplied as unassembled kit with contact body, center contact, front and rear dielectric, retainer, clamp nut, crimp sleeve, sealing boot and instruction sheet. Contacts are snap-in, rear-release.



Pin Contact

DC – 6 GHz frequency range
50 ohm nominal impedance
50 microinches gold over nickel plating

Crimp termination
VSWR 1.25:1 max. @ 6 GHz
AS39029 design, construction and performance



Socket Contact

Size #8 50 Ohm Matched-Impedance Coaxial Contacts						
RG Cable	Size	Max. Freq.	Pin Contact	Socket Contact	"A" Hex In.	mm.
RG316 (M17/113-RG316)	8	3 GHz	852-031-02F	852-030-02F	.128	3.25
RG316DS (M17/152-00001)	8	6 GHz	852-031-01F	852-030-01F	.128	3.25
LLSB-200 (M17/220-0001)	8	2.5 GHz	852-043F	852-042F	.213	5.41

Technical Data		
Specifications	Construction	Connector Compatibility
Operating temperature: -65°C. to +200°C. VSWR: 1.25:1 max. @ 6 GHz 50 ohm nominal impedance Dielectric withstanding voltage: 1300 Vac rms at sea level, 250 Vac at 50,000 feet Current rating: 1 ampere Durability: 500 mating cycles Shock: EIA-364-27 condition D Vibration: EIA-364-28 condition VI, letter J	Center contact, body, retainer, clamp nut: copper alloy, 50 microinches gold over nickel plating Front and rear dielectric: fluoroplastic Sealing Boot: fluorosilicone rubber, glass-filled PEI	MIL-DTL-38999 Series I, III and IV Glenair Series 23 SuperNine® Glenair Series 80 Mighty Mouse

Pin Contact 852-031, 852-043

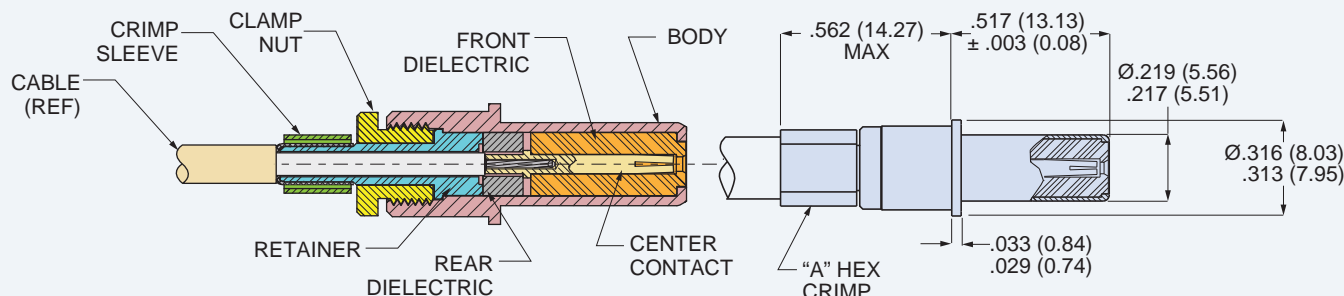

RF, Microwave and Datalink Contacts

for MIL-DTL-38999, SuperNine®, Mighty Mouse and Micro-Crimp® Connectors



Low-Loss Matched-Impedance Coaxial Contacts

Size #8 50 Ohm Matched-Impedance Coaxial Contacts

Socket Contact 852-030, 852-042

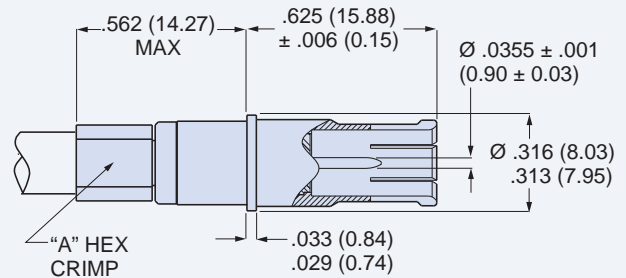
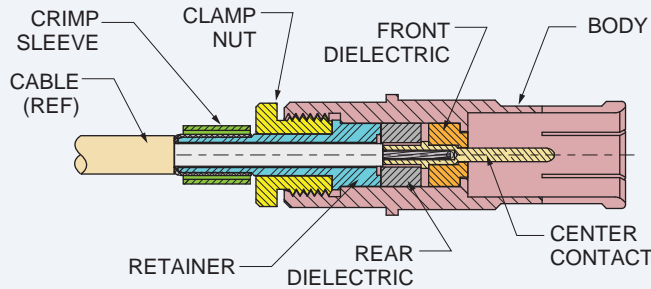

Crimp Tools, Removal Tool, Assembly Instruction Sheet

Contact Part Number	Crimp Tools				Removal Tool	Assembly Instruction Sheet
	Inner Contact Crimper	Positioner	Shield Crimper	Hex Die		
852-030	(Solder termination)	(Solder termination)	809-129 (M22520/5-01)	809-130 (M22520/5-03)	859-049 (M81969/14-12)	AI85011
852-031	(Solder termination)	(Solder termination)	809-129 (M22520/5-01)	809-130 (M22520/5-03)	859-049 (M81969/14-12)	AI85012
852-042	(Solder termination)	(Solder termination)	809-129 (M22520/5-01)	859-051 (M22520/5-05)	859-049 (M81969/14-12)	AI85040
852-043	(Solder termination)	(Solder termination)	809-129 (M22520/5-01)	859-051 (M22520/5-05)	859-049 (M81969/14-12)	AI85040

Crimp Tools

Tool terminates cable shield to contact ferrule. Use with M22520/5 die sets.



Hex Dies

Hex die for crimping ferrule to cable braid. Hardened steel, black oxide finish.



Removal Tool



Reference Coax Cable Data

	LLSB-200	RG316	RG316DS
Manufacturer	Times Microwave	(mil spec)	(mil spec)
Military Part Number	M17/220-0001	M17-113-RG316	M17/152-00001
Impedance	50 ± 2	50 ± 2	50 ± 2
Operating Frequency (Max)	2.5 GHz	3 GHz	12.4 GHz
Temperature Range	-30° to +85°C	-55° to +200°C	-55° to +200°C
Continuous Working Voltage	750 V rms, max.	900 V rms, max.	900 V rms, max.
Jacket Material	LSZH*	FEP	FEP
Jacket Diameter	.195 (4.95)	.098 (2.49)	.114 (2.90)

*Low Smoke Zero Halogen cross-linked polyolefin

Sealing Boot

Sealing boots are supplied with contacts. To order contacts less the sealing boot, remove the "F" suffix from the part number.

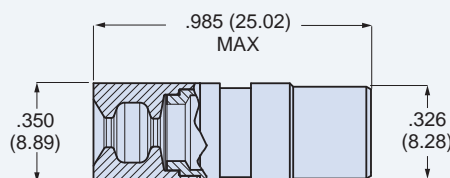
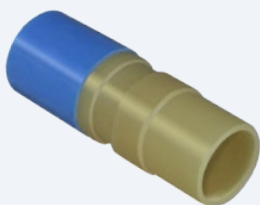

Wire Dia. (in.)	Wire Dia. (mm.)	Part Number
.090 - .130	2.3 - 3.3	859-042-01
.130 - .170	3.3 - 4.3	859-042-02
.170 - .205	4.3 - 5.2	859-042-03

RF, Microwave and Datalink Contacts

for MIL-DTL-38999, SuperNine®, Mighty Mouse and Micro-Crimp® Connectors



Low-Loss Matched-Impedance Coaxial Contacts

Size #12 50 Ohm Matched-Impedance Coaxial Contacts



Pin Contact



Socket Contact

(MIL-DTL-38999 Series II, Glenair Series 79 and Series 80)



Socket Contact

(MIL-DTL-38999 Series I, III, and IV)

Coax contacts fit Glenair Series 79 Micro-Crimp, Series 80 Mighty Mouse, and MIL-DTL-38999 Series I, II, III and IV connectors with size 12 contact cavities. 50 ohm nominal impedance. DC – 3 GHz frequency range. Contacts are snap-in, rear-release. Gold plated copper alloy, fluoroplastic insulator.

DC – 3 GHz frequency range
50 ohm nominal impedance
50 microinches gold over nickel plating

Crimp termination
AS39029 performance
Accepts RG-405-Flex low-loss microwave cable

Size 12 50 Ohm Matched-Impedance Coaxial Contacts				
RG Cable	Max. Freq.	Pin Contact	Socket Contact	
			M38999 Series I, III, IV	M38999 Series II Series 79, 80
RG178 (M17/93-RG178)	3 GHz	852-016-03	852-019-03	852-015-03
RG316 (M17/113-RG316)	3 GHz	852-016-01	852-019-01	852-015-01
RG316DS (M17/152-00001)	3 GHz	852-016-02	852-019-02	852-015-02
RG405-FLEX	3 GHz	852-018	852-037	852-017

Technical Data		
Specifications	Construction	Connector Compatibility
Operating temperature: -65°C. to +200°C. VSWR: 1.32:1 max. @ 3 GHz Nominal impedance: 50 ohms Insertion loss: 0.20 dB maximum at 3 GHz Dielectric withstanding voltage: 1000 Vac rms at sea level Current rating: 1 ampere Durability: 500 mating cycles Shock: EIA-364-27 condition D Vibration: EIA-364-28 condition VI, letter J	Center contact, body, crimp sleeve: copper alloy, 50 microinches gold over nickel plating Insulator: fluoroplastic	MIL-DTL-38999 Series I, II, III and IV Glenair Series 23 SuperNine® Glenair Series 79 Micro-Crimp® Glenair Series 80 Mighty Mouse

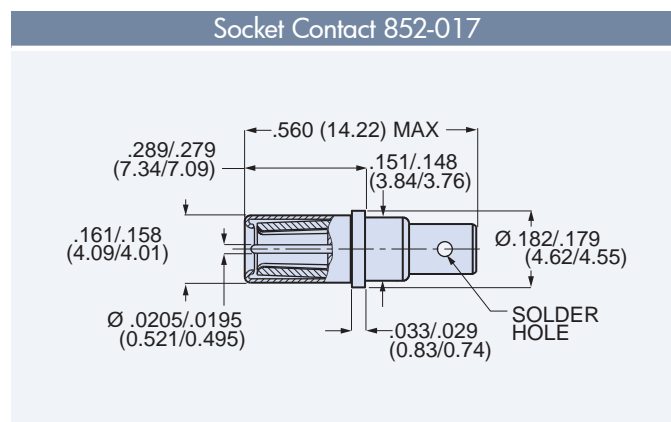
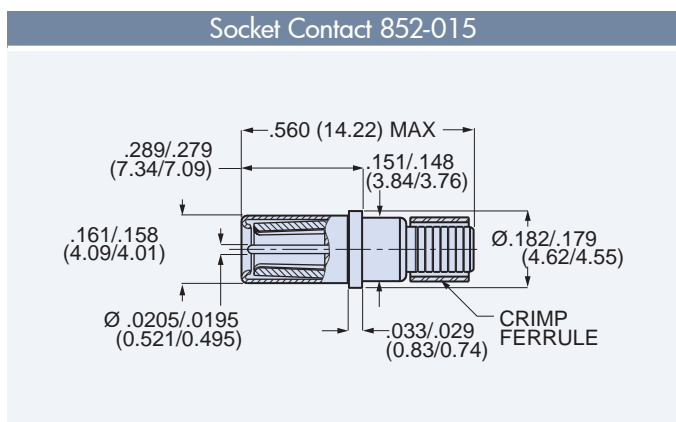

RF, Microwave and Datalink Contacts

for MIL-DTL-38999, SuperNine®, Mighty Mouse and Micro-Crimp® Connectors



Low-Loss Matched-Impedance Coaxial Contacts

Size #12 50 Ohm Matched-Impedance Coaxial Contacts

Pin Contact 852-016

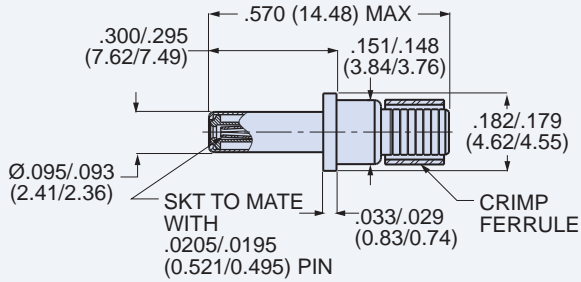

Pin Contact 852-018

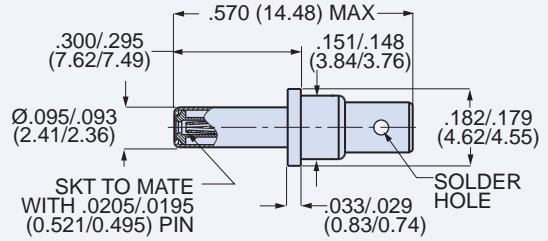

Socket Contact 852-019

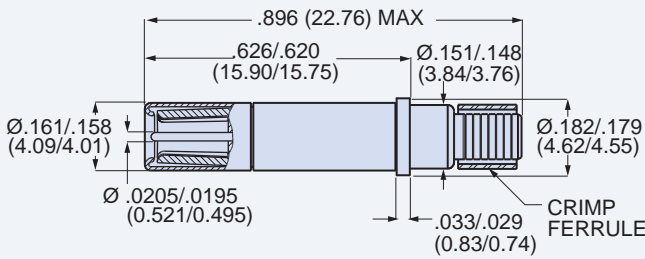

Socket Contact 852-037

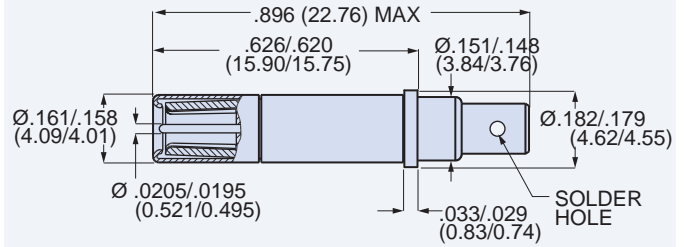

Crimp Tools, Installation/Removal Tool, Assembly Instruction Sheet

Contact Part Number	Crimp Tools				Installation/Removal Tool	Assembly Instruction Sheet
	Inner Contact		Shield Crimp Sleeve			
	Crimper	Positioner	Crimper	Hex Die		
852-015	809-128 (MH992)	859-006 (K1721)	809-129 (M22520/5-01)	809-130 (M22520/5-03)	809-132 (M81969/14-04)	AI85001
852-016	809-128 (MH992)	859-006 (K1721)	809-129 (M22520/5-01)	809-130 (M22520/5-03)	809-132 (M81969/14-04)	AI85001
852-017	(Solder termination)	(Solder termination)	(Solder termination)	(Solder termination)	809-132 (M81969/14-04)	AI85002
852-018	(Solder termination)	(Solder termination)	(Solder termination)	(Solder termination)	809-132 (M81969/14-04)	AI85002
852-019	809-015 (M22520/2-01)	859-123 (K1457)	809-129 (M22520/5-01)	809-130 (M22520/5-03)	809-132 (M81969/14-04)	AI85047
852-037	(Solder termination)	(Solder termination)	(Solder termination)	(Solder termination)	809-132 (M81969/14-04)	AI85081

Inner Contact Crimp Tools



Shield Crimp Tool



Installation/Removal Tool



RF, Microwave and Datalink Contacts

for MIL-DTL-38999, SuperNine®, Mighty Mouse and Micro-Crimp® Connectors



Low-Loss Matched-Impedance Coaxial Contacts

Size #8 75 Ohm Matched-Impedance Coaxial Contacts



Pin Contact



Socket Contact

Size 8 coax contacts fit aerospace-grade digital video cable. 75 ohm nominal impedance. 0-4 GHz frequency range. Crimp termination. Supplied as unassembled kit with contact body, center contact, outer ferrule and sealing boot. These snap-in, rear-release contacts fit Glenair Series 80 Mighty Mouse connectors and MIL-DTL-38999 Series I, III and IV connectors with size 8 contact cavities. Gold-plated copper alloy, fluoroplastic insulators.

Size 8 75 Ohm Matched-Impedance Coaxial Contacts				
Cable	Pin Contact	Socket Contact	A Hex Crimp In.	mm.
V75268, V76261, V73263 (PIC™ Wire and Cable)	852-056-01F	852-057-01F	.218	5.54
RG179 (M17/94-RG179)	852-056-02F	852-057-02F	.128	3.25
V78209 (PIC™ Wire and Cable)	852-082-01F	852-083-01F	.231	5.87
LMR-240-75 (Times Microwave)	852-082-02F	852-083-02F	.231	5.87

Technical Data		
Specifications	Construction	Connector Compatibility
Operating temperature: -65°C. to +200°C. Dielectric withstanding voltage: 500 Vac rms at sea level Current rating: 1 ampere VSWR: 1.25:1 max. @ 4 GHz 75 ohm nominal impedance Durability: 500 mating cycles Shock: EIA-364-27 condition D Vibration: EIA-364-28 condition VI, letter J	Center contact, body, retainer, clamp nut, ferrule: copper alloy, 50 microinches gold over nickel plating Front and rear insulator: fluoropolymer Sealing boot: fluorosilicone rubber, glass-filled PEI	MIL-DTL-38999 Series I, III and IV Glenair Series 23 SuperNine® Glenair Series 80 Mighty Mouse

Pin Contact 852-056

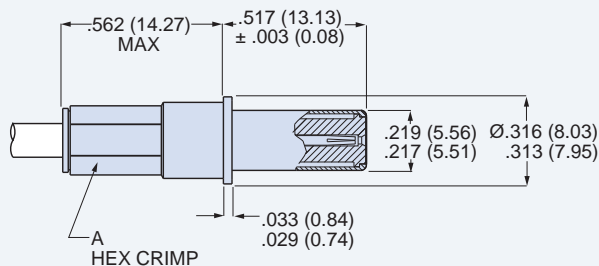
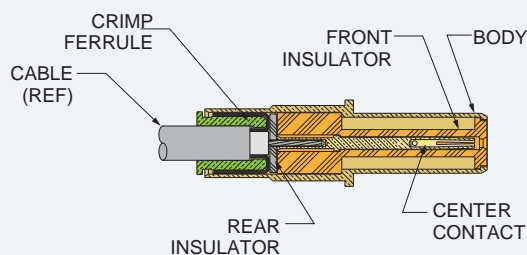

Socket Contact 852-057

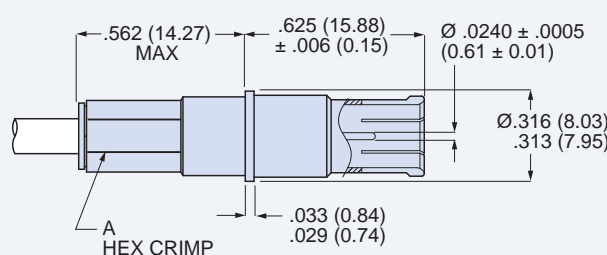
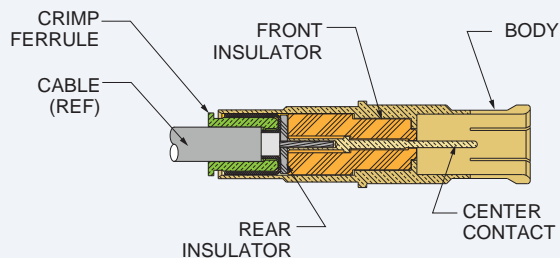

RF, Microwave and Datalink Contacts

for MIL-DTL-38999, SuperNine®, Mighty Mouse and Micro-Crimp® Connectors



Low-Loss Matched-Impedance Coaxial Contacts

Size #8 75 Ohm Matched-Impedance Coaxial Contacts

Pin Contact 852-082

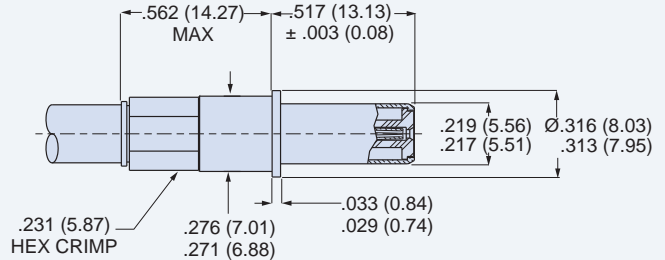
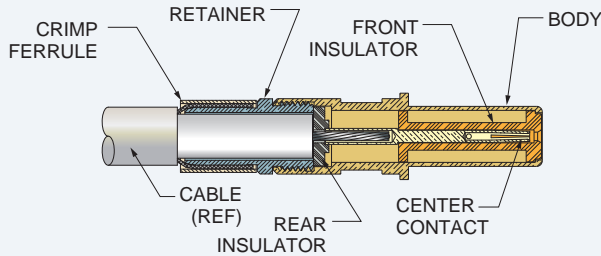

Socket Contact 852-083

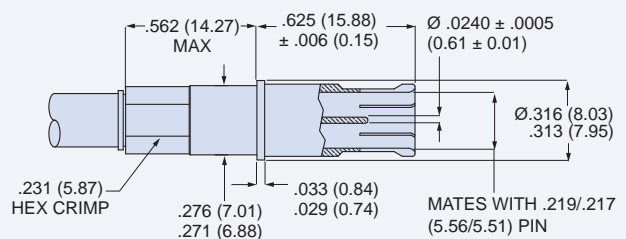
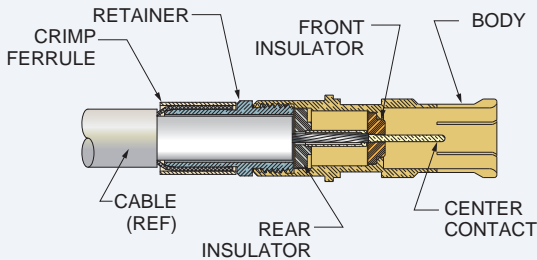

Crimp Tools, Removal Tool, Assembly Instruction Sheet

Contact Part Number	Crimp Tools				Removal Tool	Assembly Instruction Sheet
	Inner Crimper	Contact Positioner	Shield Crimp Crimper	Hex Die		
852-056-01F	809-015 (M22520/2-01)	809-240 (M22520/2-37)	809-129 (M22520/5-01)	859-047 (M22520/5-45)	859-049 (M81969/14-12)	AI85028
852-056-02F	809-015 (M22520/2-01)	809-240 (M22520/2-37)	809-129 (M22520/5-01)	809-130 (M22520/5-03)	859-049 (M81969/14-12)	AI85059
852-057-01F	809-015 (M22520/2-01)	809-240 (M22520/2-37)	809-129 (M22520/5-01)	859-047 (M22520/5-45)	859-049 (M81969/14-12)	AI85028
852-057-02F	809-015 (M22520/2-01)	809-240 (M22520/2-37)	809-129 (M22520/5-01)	809-130 (M22520/5-03)	859-049 (M81969/14-12)	AI85059
852-082	809-015 (M22520/2-01)	809-240 (M22520/2-37)	809-129 (M22520/5-01)	859-047 (M22520/5-45)	859-049 (M81969/14-12)	AI85060
852-083	809-015 (M22520/2-01)	809-240 (M22520/2-37)	809-129 (M22520/5-01)	859-047 (M22520/5-45)	859-049 (M81969/14-12)	AI85036

Inner Contact Crimp Tools



Shield Crimp Tool



Hex Die



Removal Tool



Sealing Boot

Sealing boots are supplied with contacts. To order contacts less the sealing boot, remove the "F" suffix from the part number.

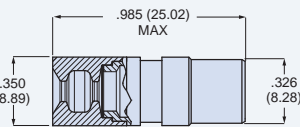
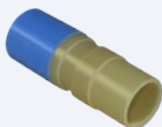

Wire Dia. (in.)	Wire Dia. (mm.)	Part Number
.090 – .130	2.3 – 3.3	859-042-01
.130 – .170	3.3 – 4.3	859-042-02
.170 – .205	4.3 – 5.2	859-042-03

RF, Microwave and Datalink Contacts

for MIL-DTL-38999, SuperNine®, Mighty Mouse and Micro-Crimp® Connectors



Low-Loss Matched-Impedance Coaxial Contacts

Size #12 75 Ohm Matched-Impedance Coaxial Contacts



75 ohm coax contacts provide DC – 3 GHz frequency range. Crimp termination. Supplied as unassembled kit with contact body, center contact and outer ferrule. These snap-in, rear-release contacts fit Glenair Series 80 Mighty Mouse, Series 79 Micro-Crimp® and MIL-DTL-38999 connectors with size 12 contact cavities. Gold-plated copper alloy, fluoroplastic insulator.

Size 12 75 Ohm Matched-Impedance Coaxial Contacts			
RG Cable	Pin Contact	Socket Contact	
		M38999 Series I, III, IV	M38999 Series II Series 79, 80
RG179 (M17/94-RG179)	852-103-02	852-106-02	852-104-02
V75268, V76261, V73263 (PIC™ Wire and Cable)	852-103-01	852-106-01	852-104-01

Technical Data		
Specifications	Construction	Connector Compatibility
<ul style="list-style-type: none"> Operating temperature: -65°C. to +200°C. Dielectric withstanding voltage: 500 Vac Current rating: 1 ampere VSWR: 1.25:1 max. @ 3 GHz 75 ohm nominal impedance Durability: 500 mating cycles Shock: EIA-364-27 condition D Vibration: EIA-364-28 condition VI, letter J 	<ul style="list-style-type: none"> Center contact, body, crimp sleeve: copper alloy, 50 microinches gold over nickel plating Insulator: fluoroplastic Hood: stainless steel, passivated 	<ul style="list-style-type: none"> MIL-DTL-38999 Series I, II, III and IV Glenair Series 23 SuperNine® Glenair Series 80 Mighty Mouse Glenair Series 79 Micro-Crimp®

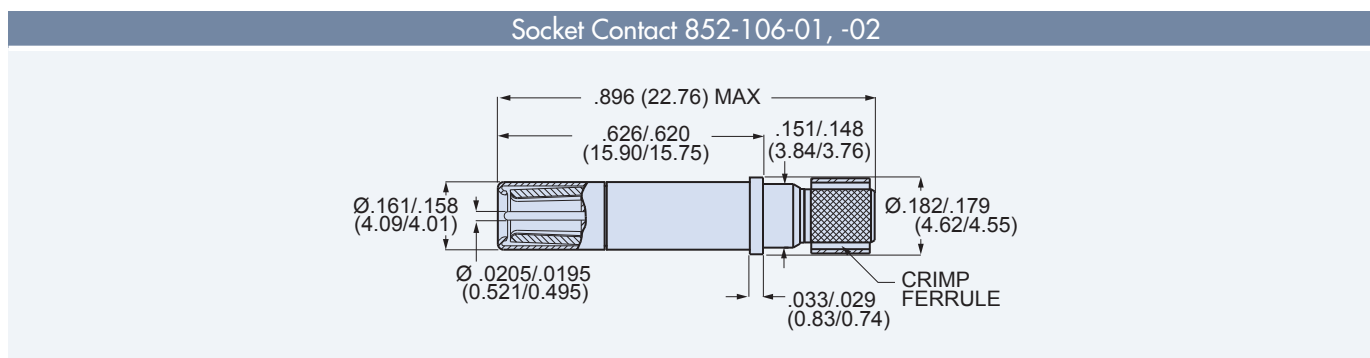
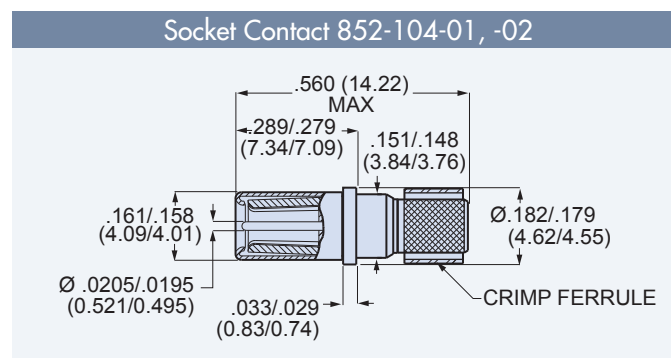
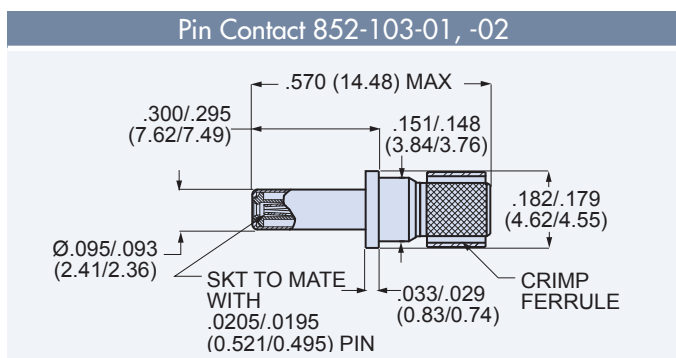

RF, Microwave and Datalink Contacts

for MIL-DTL-38999, SuperNine®, Mighty Mouse and Micro-Crimp® Connectors



Low-Loss Matched-Impedance Coaxial Contacts

Size #12 75 Ohm Matched-Impedance Coaxial Contacts

Crimp Tools, Installation/Removal Tool, Assembly Instruction Sheet						
Contact Part Number	Crimp Tools				Insertion/Removal Tool	Assembly Instruction Sheet
	Inner Contact		Shield Crimp Sleeve			
	Crimper	Positioner	Crimper	Positioner		
852-103-01	809-128 (MH992)	859-006 (K1721)	809-133 (M22520/31-01)	859-128 (GP959)	809-132 (M81969/14-04)	AI85075
852-103-02	809-128 (MH992)	859-006 (K1721)	809-129 (M22520/5-01)	809-130 (M22520/5-03)	809-132 (M81969/14-04)	AI85024
852-104-01	809-128 (MH992)	859-006 (K1721)	809-133 (M22520/31-01)	859-128 (GP959)	809-132 (M81969/14-04)	AI85075
852-104-02	809-128 (MH992)	859-006 (K1721)	809-129 (M22520/5-01)	809-130 (M22520/5-03)	809-132 (M81969/14-04)	AI85001
852-106-01	809-015 (M22520/2-01)	859-050 (M22520/2-31)	809-133 (M22520/31-01)	859-128 (GP959)	809-132 (M81969/14-04)	AI85088
852-106-02	809-015 (M22520/2-01)	859-050 (M22520/2-31)	809-129 (M22520/5-01)	809-130 (M22520/5-03)	809-132 (M81969/14-04)	AI85031

Inner Contact Crimp Tools



809-128
(MH992)



859-006
(K1721)



809-015
(M22520/2-01)



859-050
(M22520/2-31)

Shield Crimp Tool



809-133
(M22520/31-01)



859-128
(GP959)



809-129
(M22520/5-01)



809-130
(M22520/5-03)

Installation/Removal Tool



809-132
(M81969/14-04)

RF, Microwave and Datalink Contacts

for MIL-DTL-38999, SuperNine®, Mighty Mouse and Micro-Crimp® Connectors



Low-Loss Matched-Impedance Coaxial Contacts

High Performance 75 Ohm Coaxial Cable

PIC™ Aerospace-Grade Video Cable

PIC™ video cable is specially designed and manufactured for reliable performance in aircraft systems and other harsh environments involving high temperature, EMI and corrosive materials. Improved strength, lower attenuation and better shielding compared with M17/94-RG179. Silver-plated conductor, foamed FEP dielectric, tinned copper braid, FEP or ETFE jacket. Syddrol resistant, RoHS compliant, meets FAA FAR Parts 23 and 25, Appendix F flammability, complies with MIL-DTL-17.

Times Microwave LMR®-240-75 Cable

Times Microwave LMR®-240-75 flexible low-loss coaxial cable is designed for 20 year outdoor service life. Featuring excellent flexibility and bendability, LMR-240-75 cable has a UV resistant polyethylene jacket.

PIC™ V76261

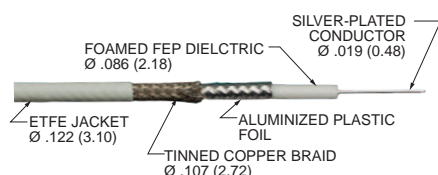

PIC™ V75268

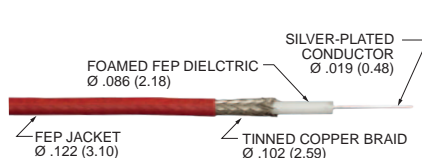

LMR®-240-75

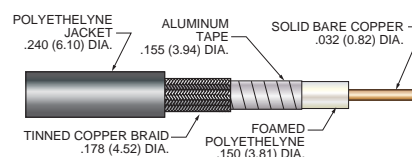

PIC™ V73263

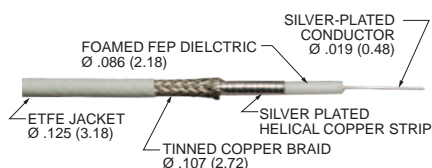

PIC™ V78209

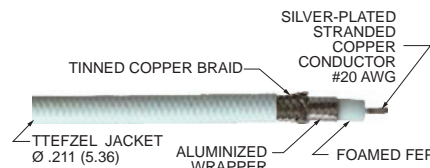

Glenair Part No.	960-130	960-131	960-132							
Manufacturer Part No.	V75268	V76261	V73263	V78209	LMR-240-75					
Manufacturer	PIC™	PIC™	PIC™	PIC™	Times Microwave					
Impedance (ohms)	75	75	75	75	75					
Shielding Effectiveness (dB)	50	90	110	90	>90					
Video Application	RS170	RS170	SMPTE 292M	SMPTE 424M	Various					
First Shield	TC Braid	TC Braid	TC Braid	TC Braid	TC Braid					
Second Shield	None	Aluminized film, 100% coverage	Silver plated helical copper strip, 100%	Aluminized film, 100% coverage	Aluminized film, 100% coverage					
Temperature Rating	-65° to +165° C	-65° to +165° C	-65° to +165° C	-55° to +150° C	-40° to +85° C					
Minimum Bend Radius	0.6 in. (15mm.)	0.6 in. (15mm.)	0.65 in. (16.5mm.)	1.1 in. (27.9mm.)	.75 in. (19.1mm.)					
Weight (lbs/100 ft.)	1.2	1.1	1.5	3.0	3.4					
Capacitance (pF/ft)	16.0	16.0	16.0	16.5	16.1					
Velocity of Propagation %	80	80	80	80	84					
Time Delay nS/ft	1.28	1.28	1.28	1.28	1.21					
Max. Attenuation	Freq.	dB/100 ft	Freq.	dB/100 ft	Freq.	dB/100 ft	Freq.	dB/100 ft	Freq.	dB/100 ft
	1 MHz	0.55	1 MHz	0.52	1 MHz	0.58	1 MHz	0.4	50 MHz	1.6
	10 MHz	1.77	10 MHz	1.71	10 MHz	1.6	10 MHz	0.9	450 MHz	5.0
	100 MHz	5.7	100 MHz	5.5	100 MHz	5.0	100 MHz	3.0	900 MHz	7.2
	400 MHz	11.8	400 MHz	11.3	400 MHz	10.6	400 MHz	6.1	1.5 GHz	9.4
	1.45 GHz	24.6	1.45 GHz	23.4	1.45 GHz	22.0	1.45 GHz	13.6	2.0 GHz	10.9
3 GHz	37.4	3 GHz	36.1	3 GHz	34.0	3 GHz	25.0	2.5 GHz	12.3	

RF, Microwave and Datalink Contacts

for MIL-DTL-38999, SuperNine®, Mighty Mouse and Micro-Crimp® Connectors



Spring-Loaded Microwave Frequency Coaxial Contacts

Product Overview and Selection Guide

Spring-Loaded Coaxial Contacts for up to 40 GHz Performance

Spring-loaded coaxial contacts maintain consistent mating geometry for optimum performance at extremely high frequencies in challenging environmental conditions. These interfaces are adapted from the field-proven and widely-deployed blind-mate contact interfaces of MIL-STD-348. Suitable for satellite communications and radar equipment, these contacts are made to the highest standards for mission-critical applications.

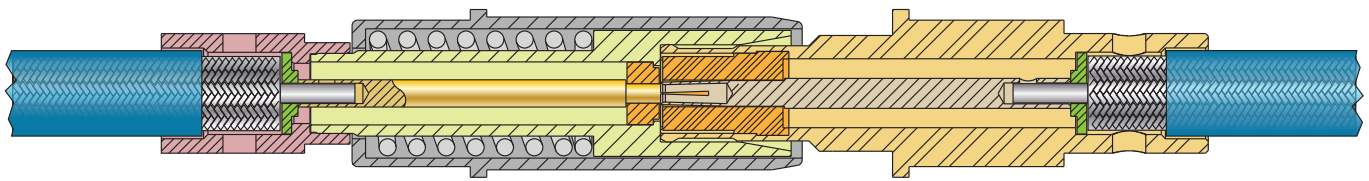

Spring-Loaded BMB Contact

Size 8 BMB Spring-Loaded Microwave Contacts Page 22



50 ohm high frequency BMB coaxial contacts snap into standard MIL-DTL-38999 connectors with size #8 contact cavities. Maximum operating frequency 18 GHz. Spring-loaded BMB pin contact assures full mating under a variety of tolerance conditions. Interface conforms to MIL-STD-348 figure 322.

Size 12 SMPM Spring-Loaded Microwave Contacts Page 24



50 ohm high frequency size #12 coaxial contacts fit Glenair Series 80 Mighty Mouse connectors, Glenair Series 79 Micro-Crimp® connectors and MIL-DTL-38999 connectors. Maximum operating frequency 40 GHz.

RF, Microwave and Datalink Contacts

for MIL-DTL-38999, SuperNine®, Mighty Mouse and Micro-Crimp® Connectors



Spring-Loaded Microwave Frequency Coaxial Contacts

Size #8 BMB Contacts for DC – 18 GHz



Pin Contact
(for use in socket connectors)



Socket Contact
(for use in pin connectors)

50 ohm high frequency BMB coaxial contacts snap into standard MIL-DTL-38999 Series I, III and IV connectors with size #8 contact cavities. Also compatible with Glenair Series 80 Mighty Mouse and Series 23 SuperNine® connectors. Maximum operating frequency 18 GHz. Spring-loaded BMB pin contact assures full mating under a variety of tolerance conditions. Interface conforms to MIL-STD-348 figure 322. Aerospace-grade construction. Solder termination.

Size 8 50 Ohm BMB Coaxial Contacts for DC – 18 GHz		
Cable	Pin Contact <i>Use in Socket Connector</i>	Socket Contact <i>Use in Pin Connector</i>
RG-402 Flex	852-070-01	852-071-01
RG-142	852-070-02	852-071-02
LL142 (Harbour Industries)	852-070-03	852-071-03
LMR-240 (Times Microwave)	852-070-04	852-071-04
RG-405 Flex	852-070-05	852-071-05

Technical Data		
Specifications	Construction	Connector Compatibility
Operating temperature: -55°C. to +125°C. Dielectric withstanding voltage: 1000 Vac rms Frequency range: DC – 18 GHz VSWR: 1.10:1 DC – 1 GHz. Above 1 GHz 1.20 + .025(freq GHz). 50 ohm nominal impedance Insertion loss: .05 dB @ 400 MHz, above 1 GHz: 0.06 x √(Freq in GHz) Durability: 500 mating cycles Shock: EIA-364-27 condition D Vibration: EIA-364-28 condition VI, letter J	Center contact: beryllium copper alloy, 50 microinches gold over nickel plating Dielectric: PTFE per ASTM D-1710 Body: beryllium copper alloy, 50 microinches gold over nickel plating Pin contact outer sleeve: 303 SST per ASTM A-582, passivated Pin contact spring: 302 or 17-7 stainless steel, passivated Sealing Boot: fluorosilicone rubber grommet, glass-filled PEI follower	BMB contacts are compatible with the following connectors with size #8 contact cavities: MIL-DTL-38999 Series I, III and IV Glenair Series 23 SuperNine Glenair Series 80 Mighty Mouse <i>Note: Pin contact 852-070 is installed in socket connectors. Socket contact 852-071 is installed in pin connectors.</i>

Construction Details: Pin Contact 852-070

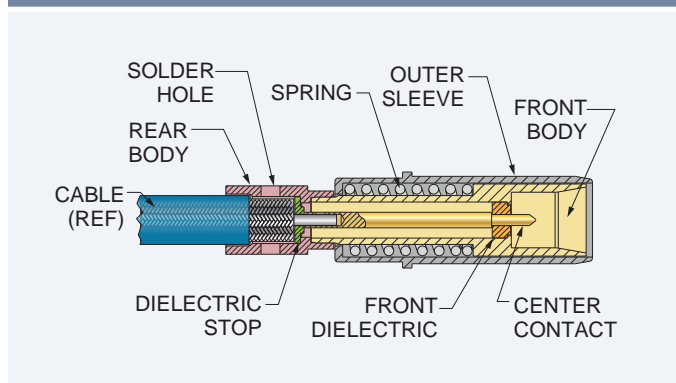

Construction Details: Socket Contact 852-071

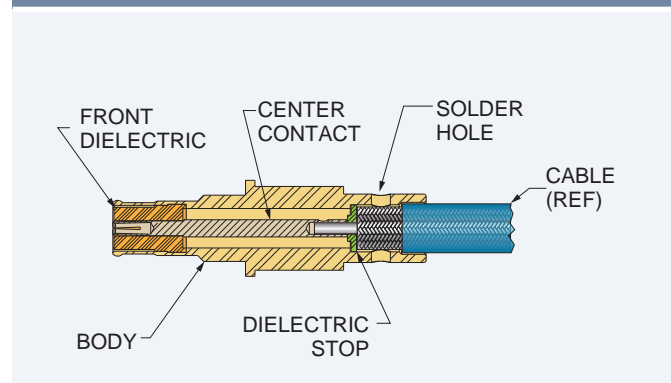

RF, Microwave and Datalink Contacts

for MIL-DTL-38999, SuperNine®, Mighty Mouse and Micro-Crimp® Connectors



Spring-Loaded Microwave Frequency Coaxial Contacts

Size #8 BMB Contacts for DC – 18 GHz

Pin Contact 852-070

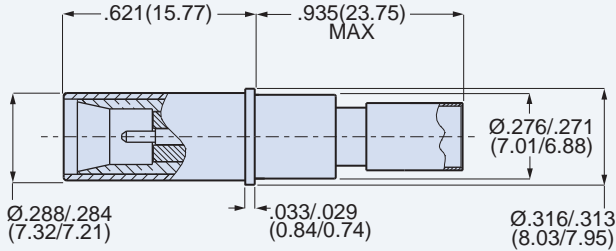

Socket Contact 852-071

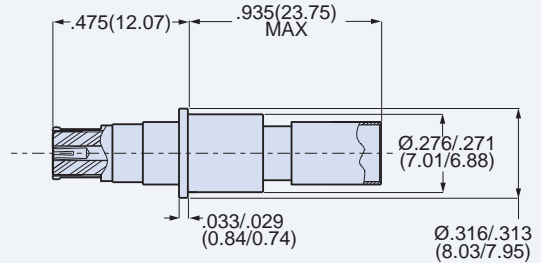

Sealing Boot

Sealing boots are supplied with contacts.

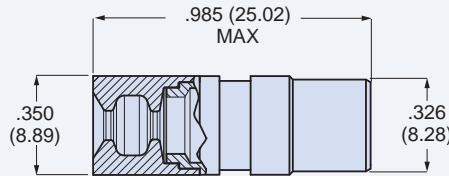
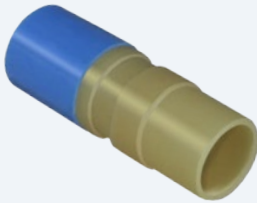

Wire Dia. (in.)	Wire Dia. (mm.)	Part Number
.090 – .130	2.3 – 3.3	859-042-01
.130 – .170	3.3 – 4.3	859-042-02
.170 – .205	4.3 – 5.2	859-042-03

Removal Tool

No tool is required for installing contact into connector.



859-049
(M81969/14-12)

RF, Microwave and Datalink Contacts

for MIL-DTL-38999, SuperNine®, Mighty Mouse and Micro-Crimp® Connectors



Spring-Loaded Microwave Frequency Coaxial Contacts

Size #12 SMPM-Type Contacts for DC – 40 GHz



Male Contact
(for use in socket connectors)



Female Contact
(for use in pin connectors)

50 ohm high frequency size #12 coaxial contacts fit Glenair Series 80 Mighty Mouse connectors, Glenair Series 79 Micro-Crimp®, Glenair Series 23 SuperNine® and MIL-DTL-38999 connectors. Maximum operating frequency 40 GHz. Spring-loaded male contact assures consistent mating dimensions and superior microwave performance. Supplied fully assembled with cable termination instruction sheet.

- DC – 40 GHz frequency range
- 50 ohm impedance
- Aerospace-grade construction
- SMPM-type Interface per MIL-DTL-348
- Spring-loaded interface
- Low insertion loss
- Solderless center contact
- VSWR 1.3 at 40 GHz

Size 12 50 Ohm SMPM-Type Coaxial Contacts for DC – 40 GHz

Cable	Female Contact (Use in Pin Connectors)	Male Contact (Use in Socket Connectors)	
		M38999 Series I, III, IV	M38999 Series II Series 79, 80
RG-405 Flex (Times Microwave TFlex-405) Tensolite LLF-1087)	852-025-01	852-024-01	852-032-01

Technical Data

Specifications

- Operating temperature: -55°C. to +125°C.
- Dielectric withstanding voltage: 500 Vac
- Ins. resistance: 5000 megohms min.
- Frequency range: DC – 40 GHz
- VSWR: 1.10 + (.005 x Freq GHz)
- 50 ohm nominal impedance
- Insertion loss: .04 x √(Freq in GHz)
- RF leakage: -(90 – Freq GHz)
- Durability: 500 mating cycles
- Shock: EIA-364-27 condition D
- Vibration: EIA-364-28 condition VI, letter J

Construction

- **Center contact:** copper alloy, 50 microinches gold over nickel plating
- **Dielectric:** PTFE per ASTM D-1710
- **Female body:** copper alloy, 50 microinches gold over nickel plating
- **Male body:** stainless steel, passivated
- **Male contact spring:** high carbon steel (music wire), nickel plated

Connector Compatibility

- MIL-DTL-38999 Series I, II, III and IV
- Glenair Series 23 SuperNine®
- Glenair Series 79 Micro-Crimp®
- Glenair Series 80 Mighty Mouse

Male Contact 852-024-01

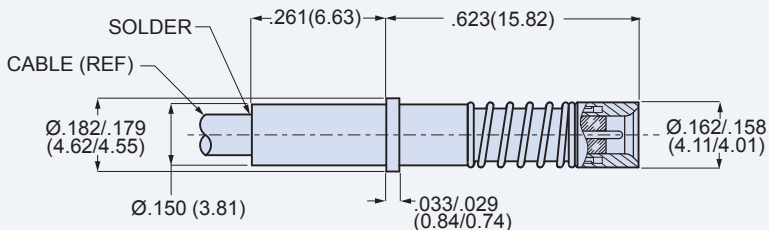

Male Contact 852-032-01

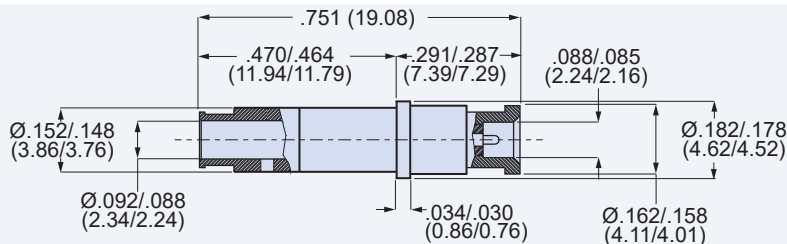

Female Contact 852-025-01

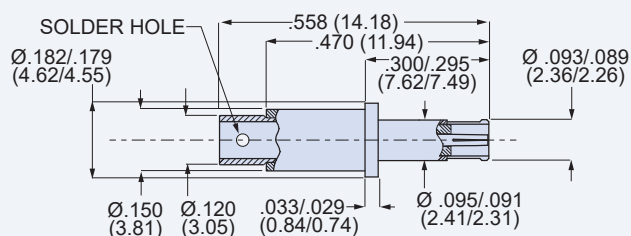

RF, Microwave and Datalink Contacts

for MIL-DTL-38999, SuperNine®, Mighty Mouse and Micro-Crimp® Connectors



Spring-Loaded Microwave Frequency Coaxial Contacts

Size #12 SMPM-Type Contacts for DC – 40 GHz

Cable Prep Dimensions for 852-024 and 852-025

Slide prepped cable into contact, then solder cable braid to contact body. See Assembly Instruction Sheet AI85009 for complete termination instructions.

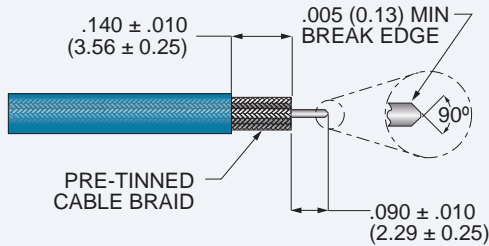

Cable Prep Dimensions for 852-032

Slide prepped cable into contact, then solder cable braid to contact body. See Assembly Instruction Sheet AI85010 for complete termination instructions.

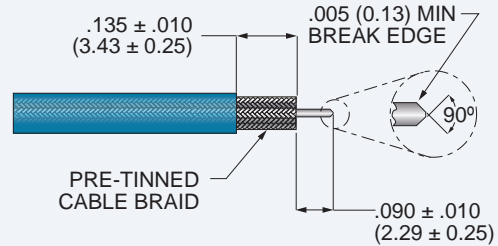

Tflex®-405 Microwave Cable

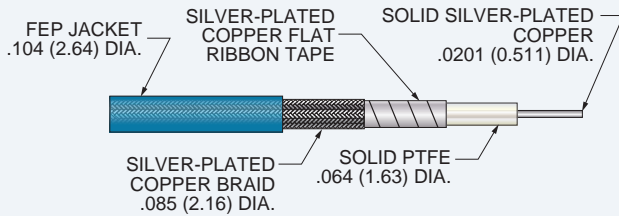

LLF-1087 Microwave Cable

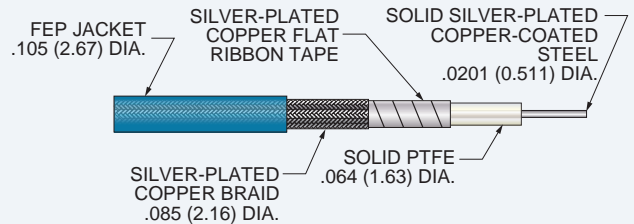

Glenair Part No.	962-001-405	
Mfgr Part No.	TFlex®-405	
Manufacturer	Times Microwave	
Impedance (ohms)	50	
Shielding Effectiveness (dB)	>100dB	
Temperature Rating	-65 °C to +125 °C	
Minimum Bend Radius	0.25 in. (6.4 mm.)	
Weight (lbs/ft.)	.015	
Capacitance (pF/ft)	29.3	
Velocity of Propagation %	69.5	
Cutoff Frequency	60 GHz	
Attenuation and Power	dB/100 ft	Watts
100 MHz	6.4	401
400 MHz	13.1	195
1 GHz	21.1	119
2 GHz	31.0	81
3 GHz	38.0	65
10 GHz	75.0	31
12 GHz	83.0	28
13.5 GHz	89.0	26
16 GHz	99.0	23
18 GHz	106.0	21

Manufacturer Part No.	LLF-1087
Manufacturer	Tensolite
Impedance (ohms)	50
Shielding Effectiveness (dB)	90
Minimum Bend Radius	0.5 in. (12.7mm)
Weight (lbs/ft.)	.013
Capacitance (pF/ft)	29
Velocity of Propagation %	70
Attenuation	dB/100 ft
400 MHz	13.7
1 GHz	22.2
3 GHz	38.9
10 GHz	74.9
18 GHz	104.3

RF, Microwave and Datalink Contacts

for MIL-DTL-38999, SuperNine®, Mighty Mouse and Micro-Crimp® Connectors



Twinax Contacts

Size #8 Concentric Twinax Contacts for M17/176-00002 Shielded Twisted Pair Cable



Concentric twinax contacts accept M17/176-00002 shielded twisted pair databus cable. These snap-in, rear-release contacts fit Glenair Series 80 Mighty Mouse connectors and MIL-DTL-38999 Series I, III and IV connectors with size #8 cavities. Crimp termination. Gold-plated copper alloy, fluoroplastic dielectric. Supplied unassembled with heatshrink boot. SAE AS39029 qualified.

Size #8 Concentric Twinax Contacts		
Cable	Pin Contact	Socket Contact
M17/176-00002	853-003-08-625 (M39029/113-625)	853-004-08-628 (M39029/114-628)

Pin Contact 853-003-08-625 (M39029/113-625)

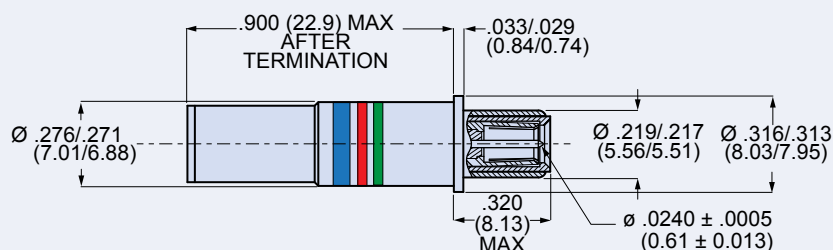

Socket Contact 853-004-08-628 (M39029/114-628)

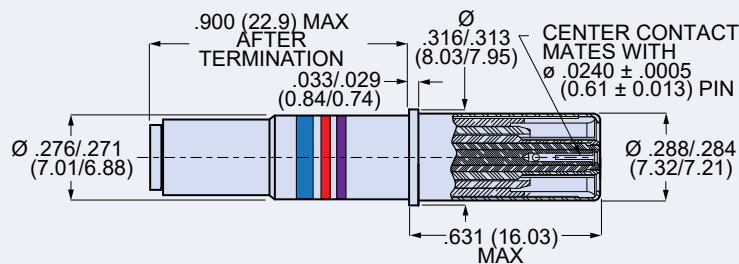

Technical Data

Specifications

- Operating temperature: -65°C. to +175°C.
- Dielectric withstanding voltage, center contact to intermediate contact: 1000 Vrms sea level, 250 Vrms at 70,000 feet
- Dielectric withstanding voltage, intermediate contact to outer contact: 500 Vrms sea level, 250 Vrms at 70,000 feet
- Contact resistance, center and intermediate contacts: 55 millivolt max. voltage drop @ 1 ampere
- Contact resistance, outer contact: 75 millivolt max. voltage drop @ 12 A.
- Durability: 500 mating cycles
- Shock: MIL-DTL-38999 Series III
- Vibration: MIL-DTL-38999 Series III

Construction

- **Center contact, intermediate contact and outer contact:** copper alloy, 50 microinches gold over nickel plating
- **Dielectric:** PEEK and PTFE
- **Socket contact hood:** stainless steel, passivated
- **Heatshrink boot:** cross-linked polyvinylidene fluoride, translucent blue, with thermoplastic hot melt adhesive

Connector Compatibility

- MIL-DTL-38999 Series I, III and IV
- Glenair Series 23 SuperNine®
- Glenair Series 80 Mighty Mouse

Heatshrink Boot

Supplied with contact. Slide onto cable before terminating contact. Slide onto contact after the cable is terminated. Apply heat to shrink the boot and melt the adhesive. Install contact into connector.

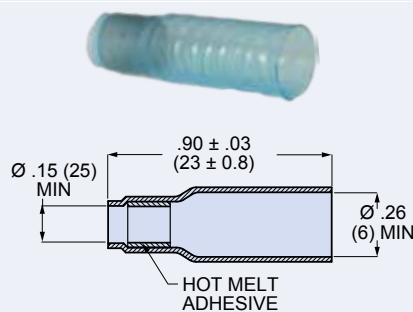

Optional Sealing Boot

Sealing boots, purchased separately, provide improved environmental seal compared to heatshrink boot supplied with contacts.

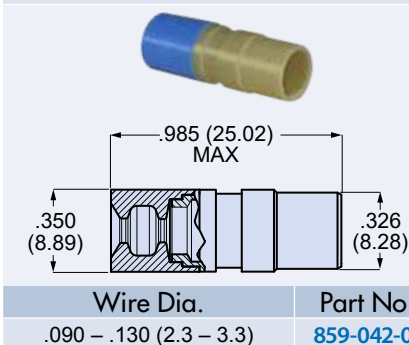

RF, Microwave and Datalink Contacts

for MIL-DTL-38999, SuperNine®, Mighty Mouse and Micro-Crimp® Connectors



Twinax Contacts

Size #8 Concentric Twinax Contacts for M17/176-00002 Shielded Twisted Pair Cable

Crimp Tools						
Contact Part Number	Center Contact		Intermediate Contact		Outer Crimp Sleeve	
	Crimper	Positioner	Crimper	Hex Die	Crimper	Hex Die
853-003-08-625 853-004-08-628	809-015 (M22520/2-01)	809-240 (M22520/2-37)	809-129 (M22520/5-01)	859-048 (M22520/5-105)	809-129 (M22520/5-01)	859-048 (M22520/5-105)

Center Contact Crimp Tools



809-015
(M22520/2-01)

809-240
(M22520/2-37)

Intermediate Contact and Outer Sleeve Crimp Tools



809-129
(M22520/5-01)

859-048
(M22520/5-105)

Removal Tool



859-049
(M81969/14-12)

M17/176-00002 Shielded Twisted Pair Databus Wire (Ref)

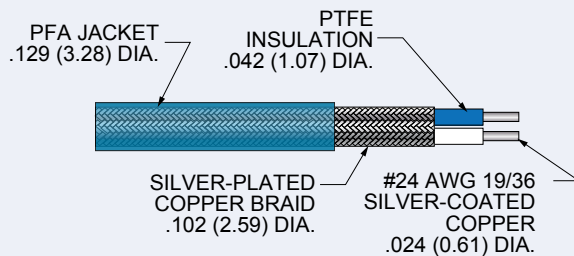

Military Specification	MIL-DTL-17/176
Military Part Number	M17/176-00002
Continuous working voltage	750 Vrms, maximum
Operating frequency	10 MHz, maximum
Characteristic Impedance (ohms)	77 ± 7 at 1 MHz
Temperature Rating	-65° to +200° C
Minimum Bend Radius	0.6 in. (15mm.)
Weight (lbs/ 1,000 ft.)	18
Capacitance (pF/ft)	24
Attenuation	1.4 dB per 100 feet, maximum at 1MHz
Velocity of Propagation	68%

RF, Microwave and Datalink Contacts

for MIL-DTL-38999, SuperNine®, Mighty Mouse and Micro-Crimp® Connectors



Twinax Contacts

Size #8 Concentric Twinax Contacts for 100 Ohm Twisted Pair Cable



Size #8 concentric twinax contacts accept 100 ohm #24 AWG controlled impedance shielded twisted pair databus cable. These snap-in, rear-release contacts fit Glenair Series 80 Mighty Mouse connectors and MIL-DTL-38999 Series I, III and IV connectors with size #8 cavities. Crimp termination. Gold-plated copper alloy. Supplied unassembled with heatshrink boot and assembly instruction sheet.

Size #8 Concentric Twinax Contacts		
Cable	Pin Contact	Socket Contact
TE Raychem 0024A0024 Gore GSC-03-81416-00	853-011	853-012

Socket Contact

Pin Contact 853-011

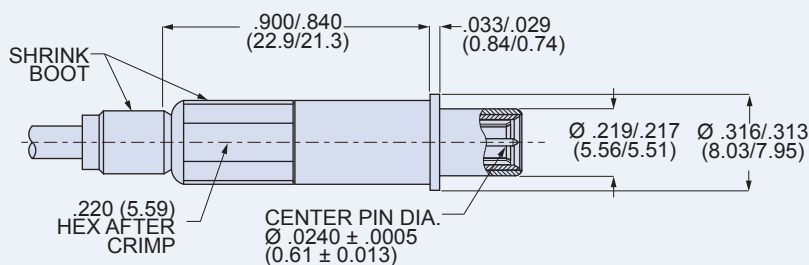

Socket Contact 853-012

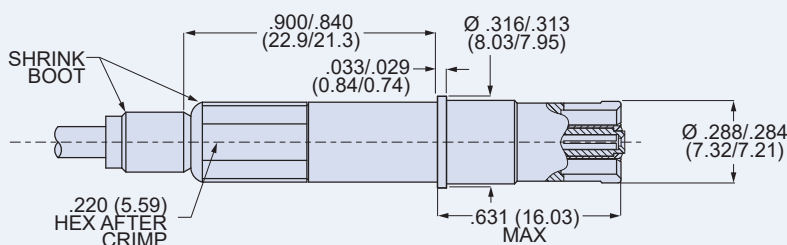

Technical Data

Specifications

- Operating temperature: -65°C. to +175°C.
- Dielectric withstanding voltage, center contact to intermediate contact: 1000 Vrms sea level, 250 Vrms at 70,000 feet
- Dielectric withstanding voltage, intermediate contact to outer contact: 500 Vrms sea level, 250 Vrms at 70,000 feet
- Contact resistance, center and intermediate contacts: 55 millivolt max. voltage drop @ 1 ampere
- Contact resistance, outer contact: 75 millivolt max. voltage drop @ 12 A.
- Durability: 500 mating cycles
- Shock: MIL-DTL-38999 Series III
- Vibration: MIL-DTL-38999 Series III

Construction

- **Center contact, intermediate contact and outer contact:** copper alloy, 50 microinches gold over nickel plating
- **Dielectric:** PEEK and PTFE
- **Socket contact hood:** stainless steel, passivated
- **Heatshrink boot:** cross-linked polyvinylidene fluoride, translucent blue, with thermoplastic hot melt adhesive

Connector Compatibility

- MIL-DTL-38999 Series I, III and IV
- Glenair Series 23 SuperNine®
- Glenair Series 80 Mighty Mouse

Heatshrink Boot

Supplied with contact. Slide onto cable before terminating contact. Slide onto contact after the cable is terminated. Apply heat to shrink the boot and melt the adhesive. Install contact into connector.

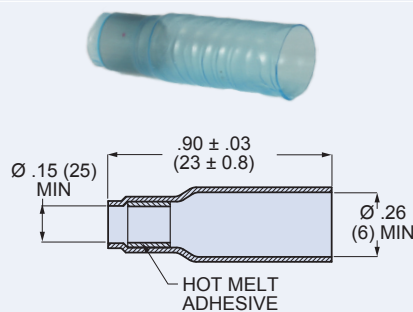

Optional Sealing Boot

Sealing boots, purchased separately, provide improved environmental seal compared to heatshrink boot supplied with contacts.

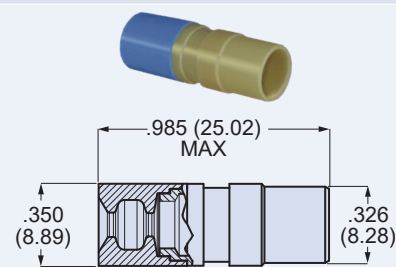

Wire Dia.	Part No.
.090 – .130 (2.3 – 3.3)	859-042-01

RF, Microwave and Datalink Contacts

for MIL-DTL-38999, SuperNine®, Mighty Mouse and Micro-Crimp® Connectors



Twinax Contacts

Size #8 Concentric Twinax Contacts for 100 Ohm #24 AWG Twisted Pair Cable

Crimp Tools							
Contact Part Number	Center Contact		Intermediate Contact		Outer Crimp Sleeve		Instruction Sheet
	Crimper	Positioner	Crimper	Hex Die	Crimper	Hex Die	
853-011 853-012	809-015 (M22520/2-01)	809-240 (M22520/2-37)	809-129 (M22520/5-01)	859-048 (M22520/5-105)	809-129 (M22520/5-01)	859-048 (M22520/5-105)	AI853-011

Center Contact Crimp Tools		Intermediate Contact and Outer Sleeve Crimp Tools		Removal Tool
809-015 (M22520/2-01)	809-240 (M22520/2-37)	809-129 (M22520/5-01)	859-048 (M22520/5-105)	859-049 (M81969/14-12)

Raychem 0024A0024 100 Ohm #24 AWG Twisted Pair Cable

Characteristic Impedance	100 ± 7 ohms @ 1 MHz
capacitance, mutual	15 pF/ft. (nominal)
Velocity of Propagation	76% (nominal)
Conductor resistance	26.5 ohms/1000 ft (nominal)
Dielectric Withstanding Voltage	1000 Vrms
Temperature Rating	-55 °C to +200 °C

Gore GSC-03-81416-00 #24 AWG Twisted Pair Cable

Characteristic Impedance	100 ± 7 ohms @ 1 MHz
capacitance, mutual	77 pF/m. (nominal)
Velocity of Propagation	78% (nominal)
Conductor resistance	85 ohms/km (nominal)
Dielectric Withstanding Voltage	1000 Vrms
Temperature Rating	-65 °C to +200 °C

RF, Microwave and Datalink Contacts

for MIL-DTL-38999, SuperNine®, Mighty Mouse and Micro-Crimp® Connectors



Twinax Contacts

Size #12 Concentric Twinax Contacts for M17/176-00002 Shielded Twisted Pair Cable



Size #12 concentric twinax contacts accept M17/176-00002 shielded twisted pair databus cable. These snap-in, rear-release contacts fit MIL-DTL-38999 Series I, III and IV connectors with size #12 cavities, and Glenair Series 23 SuperNine® connectors. Crimp termination. Gold-plated copper alloy. Interface is in accordance with JN1104, DSCC 02003 and DSCC 02004 specifications.

Size #12 Concentric Twinax Contacts		
Cable	Pin Contact	Socket Contact
M17/176-00002	853-008-1	853-009-1

Pin Contact 853-008-1

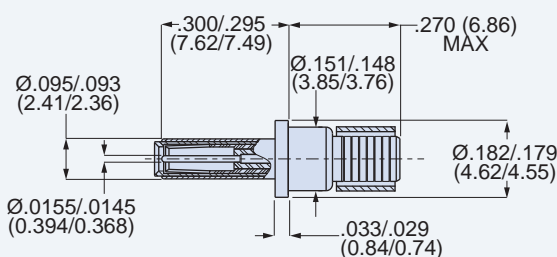

Socket Contact 853-009-1

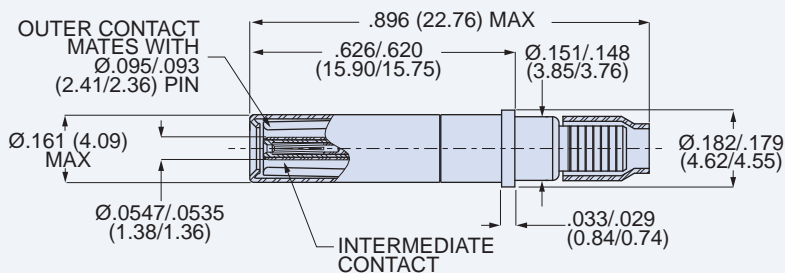

M17/176-00002 Shielded Twisted Pair Databus Wire (Ref)

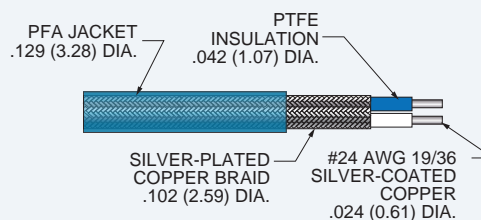

Technical Data Specifications

Operating temperature: -65°C. to +175°C.
 Operating frequency: 0 – 20 MHz
 Dielectric withstanding voltage, center contact to intermediate contact: 800 Vrms
 Dielectric withstanding voltage, intermediate contact to outer contact: 500 Vrms
 Contact resistance, center and intermediate contacts: 55 millivolt max. voltage drop @ 1 ampere
 Contact resistance, outer contact: 75 millivolt max. voltage drop @ 12 amperes
 Durability: 500 mating cycles
 Shock: EIA-364-27 condition D
 Vibration: EIA-364-28

Construction

Center contact, intermediate contact, outer contact, rear bushing: copper alloy, 50 microinches gold over nickel plating
Inner and outer crimp sleeves: copper alloy, 50 microinches gold over nickel plating
Rear bushing: copper alloy, 50 microinches gold over nickel plating
Insulators: PEEK, PTFE
Socket contact hood: stainless steel, passivated

Connector Compatibility

MIL-DTL-38999 Series I, III and IV
 Glenair Series 23 SuperNine®

Military Specification	MIL-DTL-17/176
Military Part Number	M17/176-00002
Continuous working voltage	750 Vrms, maximum
Operating frequency	10 MHz, maximum
Characteristic Impedance	77 ± 7 at 1 MHz
Temperature Rating	-65° to +200° C
Minimum Bend Radius	0.6 in. (15mm.)
Weight (lbs/ 1,000 ft.)	18
Capacitance (pF/ft)	24
Attenuation	1.4 dB per 100 feet, max. at 1MHz
Velocity of Propagation	68%

RF, Microwave and Datalink Contacts

for MIL-DTL-38999, SuperNine®, Mighty Mouse and Micro-Crimp® Connectors



Twinax Contacts

Size #12 Concentric Twinax Contacts for M17/176-00002 Shielded Twisted Pair Cable

Pin Contact Details

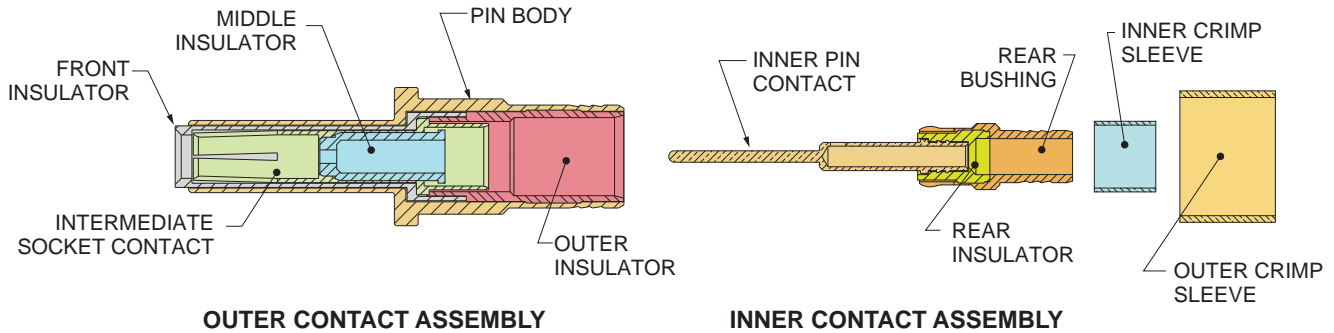

Crimp Tools, Installation/Removal Tool, Assembly Instruction Sheet

Contact Part Number	Crimp Tools						Insertion/Removal Tool	Assembly Instruction Sheet
	Inner Contact Crimper	Inner Contact Positioner	Intermediate Contact Crimper	Intermediate Contact Positioner	Outer Contact Crimper	Outer Contact Hex Die		
853-008-1 853-009-1	809-128 (MH992)	859-125 (K1365)	859-126 (GS212)	859-127 (GP1437)	809-133 (M22520/31-01)	859-128 (GP959)	809-132 (M81969/14-04)	AI85021

Center Contact Crimp Tools	Intermediate Contact Crimp Tools		Outer Contact Crimp Tools		Installation/Removal Tool	
 809-128 (MH992)	 859-125 (K1365)	 859-126 (GS212)	 859-127 (GP1437)	 809-133 (M22520/31-01)	 859-128 (GP959)	 808-132 (M81969/14-04)

RF, Microwave and Datalink Contacts

for MIL-DTL-38999, SuperNine®, Mighty Mouse and Micro-Crimp® Connectors



Twinax Contacts

Size #8 Differential Twinax Contacts

Differential twinax contacts accept shielded twisted pair cable. These snap-in, rear-release contacts fit Glenair Series 80 Mighty Mouse connectors and Glenair 233-217 MIL-DTL-38999 type connectors with keyed inserts. Crimp termination. 24 and 26 AWG versions. 68 ohm, 75 ohm, 77 ohm and 100 ohm impedance. Gold-plated copper alloy. Supplied unassembled with sealing boot and instruction sheet.



Size #8 Differential Twinax Contacts				
Shielded Twisted Pair Cable	Wire Size (AWG)	Impedance (ohms)	Pin Contact	Socket Contact
GSC-03-83971-00 (Gore)	24	100	853-014-02F	853-013-02F
0024A0024 (TE Raychem)	24	100	853-014-04F	853-013-04F
M17/176-00002 (MIL-DTL-17)	24	77	853-014-05F	853-013-05F
24443/52088X2 (Tensolite ref: 5M2022-003)	24	75	853-014-05F	853-013-05F
ST5M1212-002 (McDonnell Douglas)	24	68	853-025-01F	853-024-01F
DXN2603 (Gore)	26	100	853-014-09F	853-013-09F
7726D0664 (TE Raychem)	26	77	853-025-02F	853-024-02F

Technical Data		
Specifications	Construction	Connector Compatibility
<ul style="list-style-type: none"> Operating temperature: -65°C. to +175°C. Operating frequency: consult factory Dielectric withstanding voltage, inner contact to inner contact: 1000 Vrms Dielectric withstanding voltage, inner contact to outer body: 500 Vrms Insulation resistance: 5000 megohms min. Contact resistance, inner contacts: 55 millivolt max. voltage drop @ 1 ampere Contact resistance, outer body: 75 millivolt max. voltage drop @ 12 amperes Durability: 500 mating cycles Shock: EIA-364-27 condition D Vibration: EIA-364-28 condition VI, letter J 	<ul style="list-style-type: none"> Inner contacts, outer body: copper alloy, 50 microinches gold over nickel plating Crimp ferrule: copper alloy, 50 microinches gold over nickel plating Insulators: PPS Sealing boot: fluorosilicone rubber grommet, glass-filled PEI follower 	<ul style="list-style-type: none"> Differential twinax contacts have an alignment key and are not for use in standard MIL-DTL-38999 connectors Glenair 233-217 MIL-DTL-38999 Series III connectors with keyed inserts for contact alignment. Glenair Series 80 Mighty Mouse. <i>All standard Mighty Mouse connectors with size #8 contacts have keyed contact cavities for proper alignment of differential twinax, quadax, and octaxial contacts.</i>

Sealing Boot

Sealing boots are supplied with contacts. To order contacts without sealing boots, delete the "F" suffix from the part number

The diagram shows a cross-section of the sealing boot with the following dimensions:

- Overall length: .985 (25.02) MAX
- Inner diameter: .350 (8.89)
- Outer diameter: .326 (8.28)

RF, Microwave and Datalink Contacts

for MIL-DTL-38999, SuperNine®, Mighty Mouse and Micro-Crimp® Connectors



Twinax Contacts

Size #8 Differential Twinax Contacts

Pin Contact 853-014 and 853-025

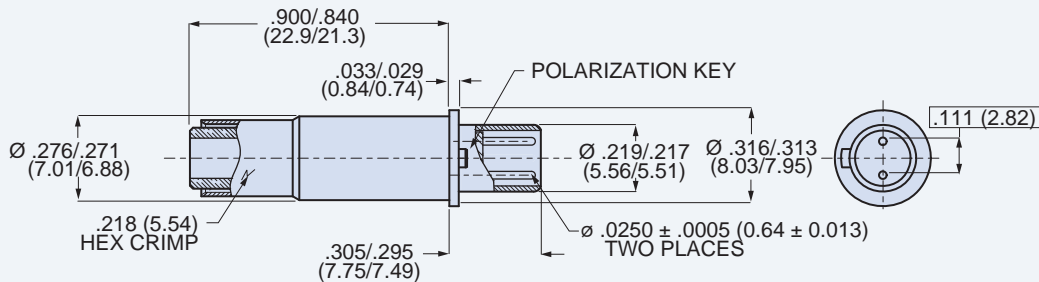

Socket Contact 853-013 and 853-024

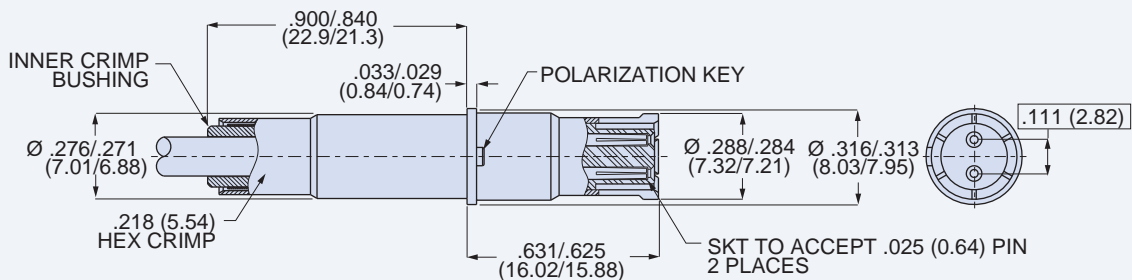

Crimp Tools, Removal Tool, Assembly Instruction Sheet

Contact Part Number	Inner Contacts		Outer Body		Removal Tool	Assembly Instruction Sheet
	Crimper	Positioner	Crimper	Hex Die		
853-013 853-014 853-024 853-025	809-015 (M22520/2-01)	809-240 (M22520/2-37)	809-129 (M22520/5-01)	859-007 (M22520/5-45)	859-049 (M81969/14-12)	AI85007

Inner Contact Crimp Tools



809-015
(M22520/2-01)



809-240
(M22520/2-37)

Outer Body Crimp Tools



809-129
(M22520/5-01)



859-007
(M22520/5-45)

Removal Tool



859-049
(M81969/14-12)

RF, Microwave and Datalink Contacts

for MIL-DTL-38999, SuperNine[®], Mighty Mouse and Micro-Crimp[®] Connectors



Twinax Contacts

Size #8 Differential Twinax Contacts

Shielded Twisted Pair Cables for Differential Twinax Contacts

Raychem 0024A0024 100 Ohm 24 AWG Twisted Pair Cable

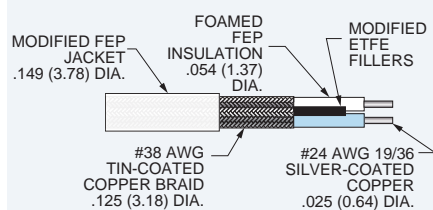

Impedance	100 ± 7 ohms @ 1 MHz
DWV rating	1000 Vrms
Temperature Rating	-55° to +200° C

Gore GSC-03-83971-00 100 Ohm 24 AWG Twisted Pair Cable

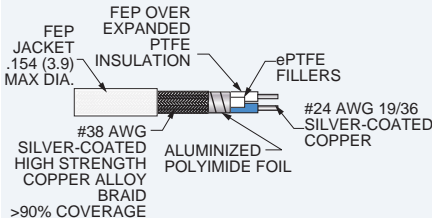

Impedance	100 ± 7 ohms
DWV Rating	1000 Vrms
Temperature Rating	-65° to +200° C

Raychem 7726D0664-9 77 Ohm 26 AWG Twisted Pair Cable

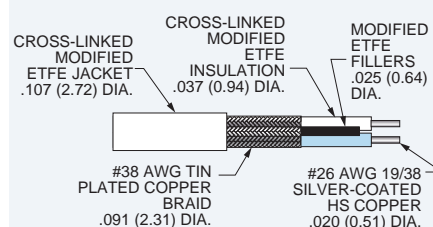

Impedance	77 ± 5 ohms @ 1 MHz
DWV rating	1000 Vrms
Temperature Rating	-65° to +150° C

Gore DXN2603 100 Ohm 26 AWG Twisted Pair Cable

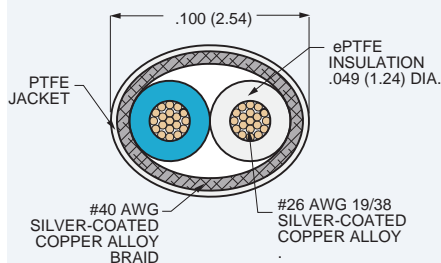

Impedance	100 ± 10 ohms
Attenuation	31.2 dB / 100 ft. @ 1 GHz
Temperature Rating	+200° C

M17/176-00002 Shielded Twisted Pair Databus Cable

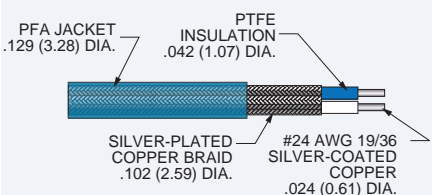

Impedance (ohms)	77 ± 7 at 1 MHz
DWV Rating	1000 Vrms
Temperature Rating	-65° to +200° C

Tensolite 24443/52088X2 75 Ohm 24 AWG Twisted Pair Cable

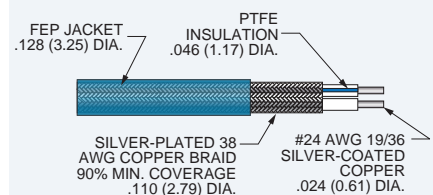

Impedance (ohms)	75 ± 5
DWV Rating	1500 Vrms
Temperature Rating	-65° to +200° C

ST5M1212-002 68 Ohm 24 AWG Twisted Pair Cable

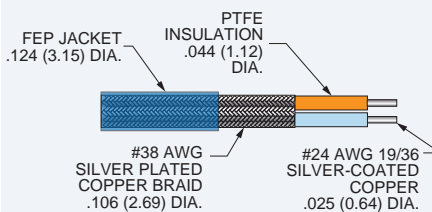

Impedance	68 ± 4 ohms
DWV rating	1500 Vrms
Temperature Rating	-65° to +200° C

RF, Microwave and Datalink Contacts

for MIL-DTL-38999, SuperNine®, Mighty Mouse and Micro-Crimp® Connectors



Ultra-Twinax Contacts

Size #12 Ultra-Fast Differential Twinax Contacts for DC – 10 GHz Frequency Range



Glenair Ultra-Twinax differential twinax contacts are suited for multi-gigabit data rate applications such as CML, LVDS and other advanced digital communications protocols. Size #12 100 ohm contacts feature DC – 10 GHz frequency range. Use with high-speed #30 AWG twisted pair cable 963-102-30. These contacts are compatible with Glenair Series 80 Mighty Mouse connectors with size #12 cavities. Snap-in, rear release. Solder termination. Supplied as kit with body, front insulator-solder contact subassembly, and rear insulator. Gold-plated copper alloy, glass-filled PTFE insulator.

Features

- DC – 10 GHz frequency range
- 100 ohm impedance
- Aerospace-grade construction
- Low insertion loss

Applications

- LVDS
- SATA 3.0
- DisplayPort
- CML

Size #12 Ultra-Twinax Contacts					
Cable	Wire Size (AWG)	Impedance (ohms)	Pin Contact	Socket Contact	Assembly Instruction Sheet
963-102-30 (Glenair)	30	100	853-016-01	853-015-01	AI85051

Technical Data

Specifications	Construction	Connector Compatibility
Operating temperature: -65°C. to +105°C. Operating frequency: 0 – 10 GHz Impedance: 100 ohms VSWR: 1.1 + (.03 X Freq GHz) Insertion loss : (.33 X Freq GHz) Dielectric withstanding voltage: 500 Vrms Insulation resistance: 5000 megohms min. Durability: 500 mating cycles	Inner contacts, outer body: copper alloy, 50 microinches gold over nickel plating Insulator: glass-filled PTFE Rear insulator: PPS Socket hood: stainless steel, passivated	Glenair Series 80 Mighty Mouse. <i>All standard Mighty Mouse connectors with size #12 contact accommodation have keyed contact cavities for proper alignment of ultra-twinax contacts.</i>

Pin Contact Design Features

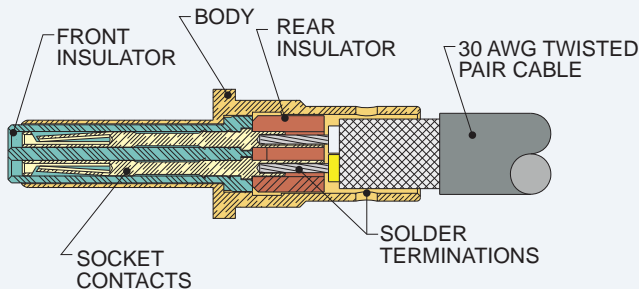

Socket Contact Design Features

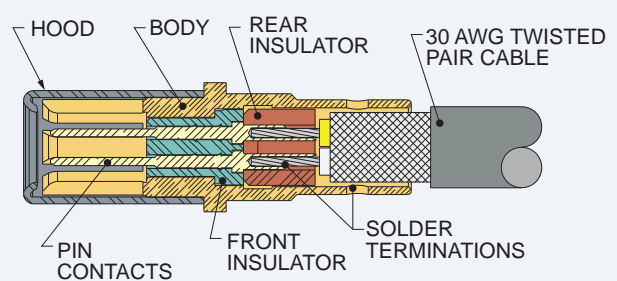

RF, Microwave and Datalink Contacts

for MIL-DTL-38999, SuperNine[®], Mighty Mouse and Micro-Crimp[®] Connectors



Twinax Contacts

Size #12 Ultra-Fast Differential Twinax Contacts for DC – 10 GHz Frequency Range

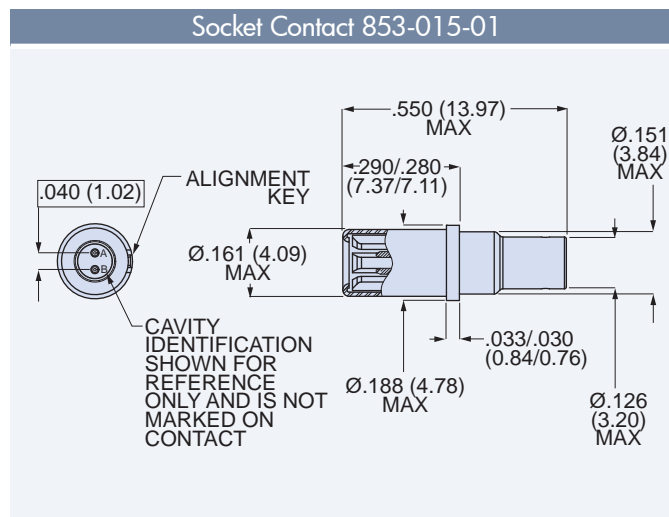
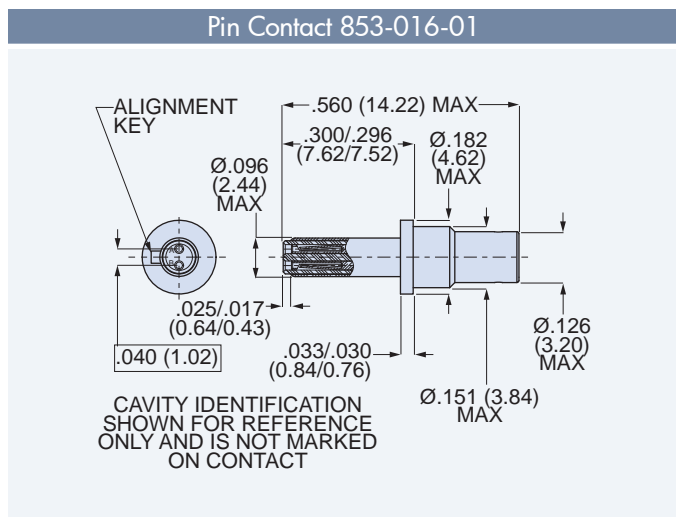

Performance Data

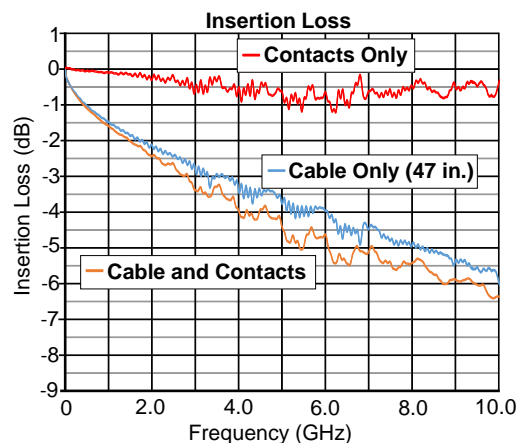
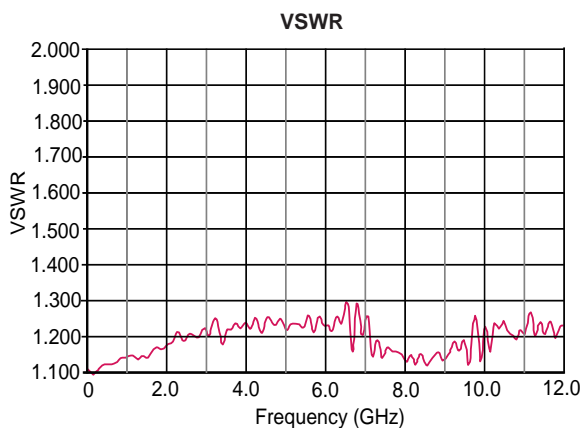

963-102-30 100 Ohm Twisted Pair Cable Specifications

Conductors	30 AWG silver-coated high strength copper alloy, 19/42 strand
Insulation	PFA, white and yellow, .032 dia.
Inner shield	.0015" aluminum/polyester tape
Outer shield	Silver-coated 40 AWG braid, 90% minimum coverage
Jacket	PFA, black
Temperature Rating	-65° to +105° C
Impedance	100 ± 10 ohms
Capacitance	15.0 pF/ft (cond-cond)
DC resistance	98.55 ohms/1000 ft. maximum
Attenuation (nominal)	40 dB @ 500 MHz, 56dB @ 1 GHz
Velocity of Propagation	80%

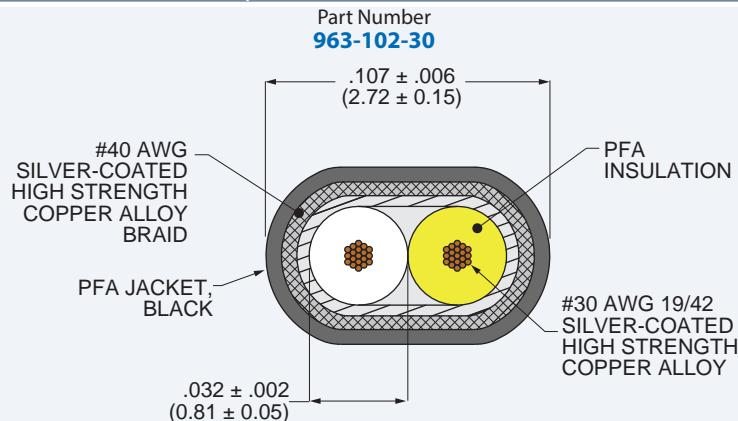

RF, Microwave and Datalink Contacts

for MIL-DTL-38999, SuperNine®, Mighty Mouse and Micro-Crimp® Connectors



Quadrax Contacts

Size #8 100 Ohm and 150 Ohm Quadrax Contacts



Socket Contact

Quadrax contacts are size 8 multi-pin contacts with four signal pins and an outer contact body. These contacts are used for harsh environment military and aerospace data networks using star quad cable. Crimp termination. Two types are available: 100 ohm for 100BASE-T Ethernet and 150 ohm for fibre channel. Compatible with Glenair Series 80 Mighty Mouse and Glenair 233-217 SuperNine® connectors. Supplied as unassembled kit with outer body, (4) inner contacts, shield crimp ferrule, insulators, sealing boot and instruction sheet.

DC – 3 GHz frequency range
100 ohm and 150 ohm versions
Arinc 664 compatible

Snap-in, rear release
Sealing boot included
Gold plated copper alloy

Size #8 100 Ohm Quadrax Contacts

Wire Size (AWG)	Imped. (ohms)	Ref Cable Diameter		A Hex Crimp		Cable Accomodation		Pin Contact	Socket Contact
		In.	mm.	In.	mm.	Mfgr.	Part Number		
22	100	.190	4.83	.231	5.86	Tensolite	NF22Q100-01	854-001-05F	854-002-05F
24	100	.160	4.06	.218	5.54	PIC	E51424	854-001-02F	854-002-02F
						(various)	AS6070-1		
						Gore	GSC-03-84608-00		
						Tensolite	NF24Q100-01		
24	100	.175	4.45	.218	5.54	TE	CEC-RWC-18664	854-001-04F	854-002-04F
						Draka	F 4704-4		
						PIC	E50424		
26	100	.137	3.48	.218	5.54	(various)	ABS1503KD24	854-001-01F	854-002-01F
						Tensolite	NF26Q100-01		
						PIC	E51426		

Size #8 150 Ohm Quadrax Contacts for Fibre Channel (not intermateable with 100 ohm quadrax contacts)

26	150	Fibre Channel	.195	4.95	.231	5.86	Tensolite	26473/02006X-4(LD)	854-015-02F	854-014-02F
							Gore	RCN8328		

Technical Data

Specifications	Construction	Connector Compatibility
Operating temperature: -65°C. to +175°C. Operating frequency: DC – 3 GHz Characteristic Impedance: 100 ±10 ohms or 150 ± 10 ohms Dielectric withstanding voltage, inner to inner contact: 1000 Vrms sea level, 250 Vrms 70,000 feet. Dielectric withstanding voltage, inner to outer contact: 500 Vrms sea level, 250 Vrms 70,000 feet. Insulation resistance: 5000 megohms min. Durability: 500 mating cycles Vibration: MIL-DTL-38999 Series III Shock: MIL-DTL-38999 Series III	Inner contacts, outer contact, shield crimp ferrule: copper alloy, 50 microinches gold over nickel plating Insulator: PPS Sealing boot grommet: fluorosilicone Sealing boot body: rigid thermoplastic, PEI or equivalent	Quadrax contacts have an alignment key and are not for use in standard MIL-DTL-38999 connectors Glenair Series 80 Mighty Mouse Glenair 233-217 SuperNine®

RF, Microwave and Datalink Contacts

for MIL-DTL-38999, SuperNine[®], Mighty Mouse and Micro-Crimp[®] Connectors



Quadrax Contacts

Size #8 100 Ohm and 150 Ohm Quadrax Contacts

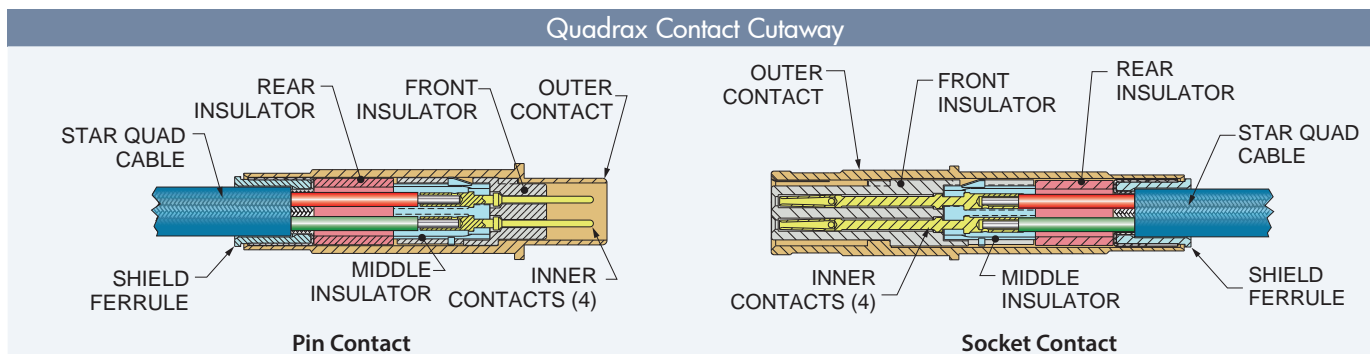

Pin Contact 854-001 and 854-015

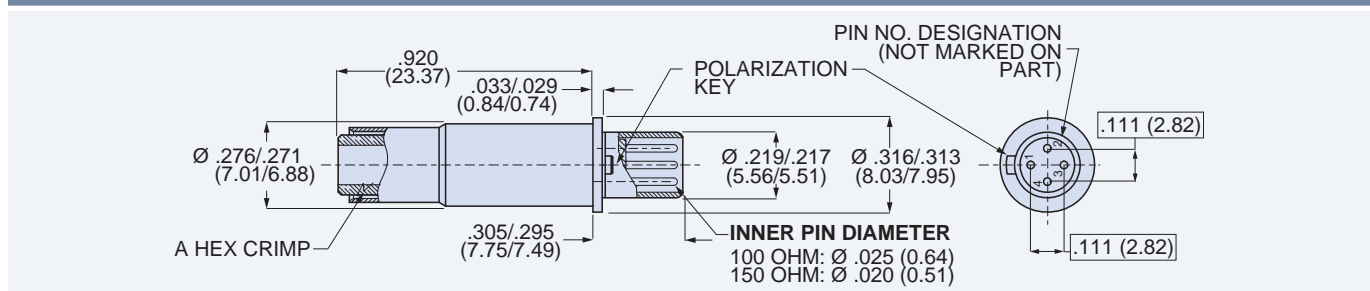

Socket Contact 854-002 and 854-014

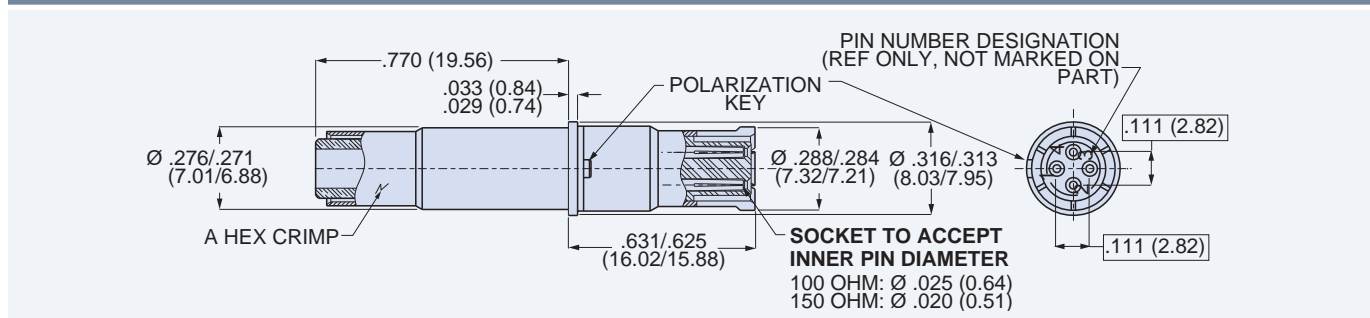

Crimp Tools, Removal Tool, Assembly Instruction Sheet

Contact PN	Inner Contacts		Outer Body		Removal Tool	Assembly Instructions
	Crimper	Positioner	Crimper	Hex Die		
854-001 854-002	809-015 (M22520/2-01)	809-240 (M22520/2-37)	809-129 (M22520/5-01)	859-007 (M22520/5-45)	859-049 (M81969/14-12)	AI854-001
854-014 854-015	809-015 (M22520/2-01)	809-240 (M22520/2-37)	809-129 (M22520/5-01)	859-007 (M22520/5-45)	859-049 (M81969/14-12)	AI85038

Inner Contact Crimp Tools Outer Body Crimp Tools Removal Tool



Sealing Boot

Sealing boots are supplied with contacts. To order contacts without sealing boots, remove the "F" suffix from the part number.

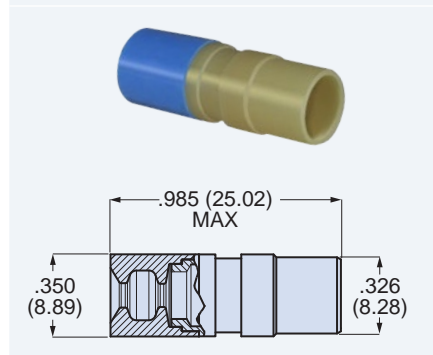

RF, Microwave and Datalink Contacts

for MIL-DTL-38999, SuperNine®, Mighty Mouse and Micro-Crimp® Connectors



Quadrax Contacts

Aerospace-Grade Star Quad Cable

About Star Quad Cable

Star quad cables are widely used for 100 ohm ARINC 664 10/100BASE-T Ethernet and 150 ohm fibre channel. Quad cable, when paired with quadrax contacts, offers improved EMI protection and better data integrity compared to shielded twisted data pair cable terminated to individual connector pins. This illustration depicts SAE AS6070/1 high speed data quad cable. This construction, with two shields and fluoropolymer insulation, is typical of aerospace star quad cables available from Gore, Carlisle (Tensolite), PIC, TE, Draka and other cable manufacturers. The table below lists standard star quad cables available from Glenair.

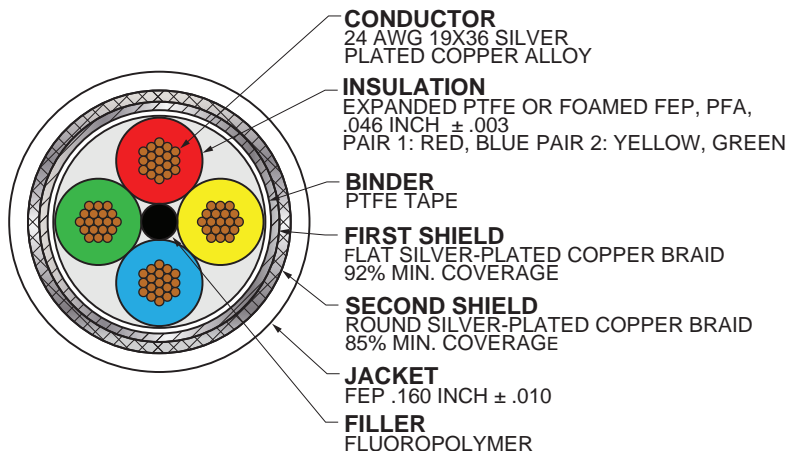

Star Quad Cables Available From Glenair

Glenair Part No.	963-019	963-020	963-021	963-022	963-023	963-024
Manufacturer Part No.	NF22Q100-01	NF24Q100-01	NF26Q100-01	E50424	E51424	E51426
Manufacturer	Tensolite	Tensolite	Tensolite	PIC	PIC	PIC
Construction Details						
Conductor Size (AWG)	22	24	26	24	24	26
Conductor Material	SCC	SCCA	SCCA	SCC	SCC	SCC
Insulation	Extruded PTFE over fused PTFE tape	Extruded PTFE over fused PTFE tape	Extruded PTFE over fused PTFE tape	PTFE	Foamed FEP	Foamed FEP
Insulation Color	Pair 1: Red, Blue Pair 2: Green, Yellow	Pair 1: Red, Blue Pair 2: Green, Yellow	Pair 1: Red, Blue Pair 2: Green, Yellow	Pair 1: Red, Blue Pair 2: Green, Yellow	Pair 1: Red, Blue Pair 2: Green, Yellow	Pair 1: Red, Blue Pair 2: Green, Yellow
Binder	PTFE	PTFE	PTFE		PTFE	PTFE
Shield	Inner TCC flat braid, outer TCC round braid	Inner TCC flat braid, outer TCC round braid	Inner TCC flat braid, outer TCC round braid	Inner foil, outer SCC round braid	Inner TCC flat braid, outer TCC round braid	Inner TCC flat braid, outer TCC round braid
Jacket	FEP	FEP	FEP	FEP	ETFE	ETFE
Jacket Color	Translucent Blue	Translucent Blue	Translucent Blue	Translucent Blue	White	White
Nominal Cable Diameter	.190	.163	.137 (3.48)	.170 (4.32)	.161 (4.09)	.161 (4.09)
Specifications						
Impedance (ohms)	100	100	100	100	100	100
Temperature Rating	+150 °C	+150 °C	+150 °C	+200 °C	+150 °C	+150 °C
Weight (lbs/100 ft.)	3.4	2.45	1.8	2.6	2.2	1.8
Capacitance (pF/ft)	13	13	13	13	13	14.5
Velocity of Propagation %	80	80	80	69.5	80	70
Time Delay pS/ft	137	137	137			
Max. Attenuation dB/100 ft., 100 MHz	7.3	9.2	11.0	11.5	9.2	11.0
Min. NEXT (dB), 100 MHz	35	35	35	35.3	35.3	35.3
Min. SRL (dB), 100 MHz	16	16	16	20.1	16.0	16.0
Notes						
SCC silver-coated copper SCCA silver-coated copper alloy TCC tin-coated copper Cables are Skydrol resistant, RoHS compliant and meet the FAA flammability requirements of FAR Part 23 and 25, Appendix F						

RF, Microwave and Datalink Contacts

for MIL-DTL-38999, SuperNine®



854-035 Quadrax Cable Assemblies

Size #8 100 Ohm Quadrax Cable Assemblies, How-to-Order

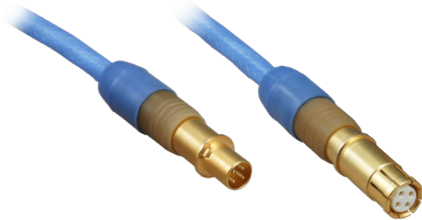

Quadrax contact, Pin and Socket

Aerospace-grade or commercial-grade cable. 100% tested. Save assembly time and cost with quadrax cordset assemblies. These assemblies are available with pin/pin, pin/socket, socket/socket, pin/RJ45 or socket/RJ45 configurations. Star quad aerospace-grade high temperature cable has fluoropolymer construction. Compatible with Glenair Series 23 and Series 80 connectors. Optional sealing boot available. **Quadrax contacts must be installed in keyed connectors before mating to prevent misalignment and contact damage.**

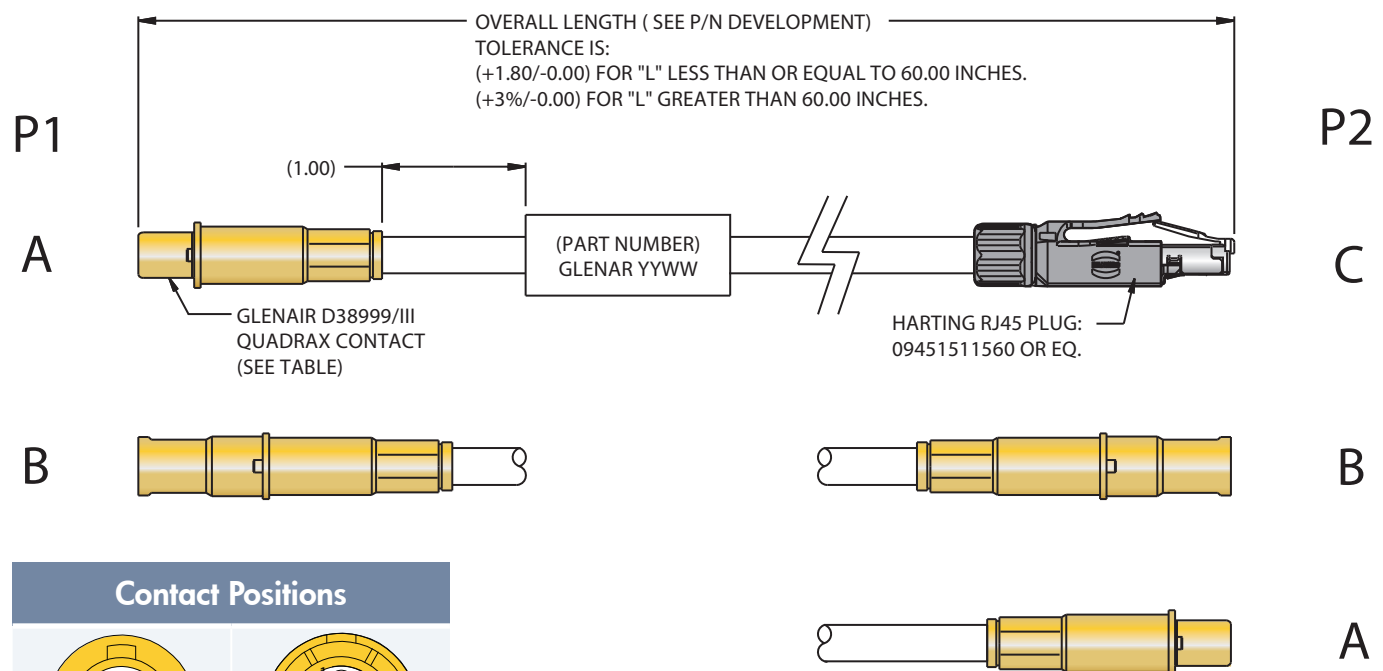

Contact Positions

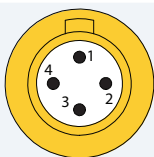

Mating face of Pin

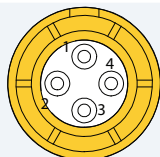

Mating face of Socket

Technical Data

- ❑ For use with 100 BASE-T Ethernet applications. For 1000 BASE-T Ethernet applications, please consult factory.
- ❑ Refer to individual contact and cable data sheets for construction details
- ❑ 100% tested for shorts, continuity and IR
- ❑ **Operating temp.:** -65° to +125°C, aerospace-grade
- ❑ **Impedance:** 100 ohms
- ❑ **DWV:** 500 Vrms
- ❑ **IR:** 5000 megohms min @ 200VDC.

D38999 Series III and Mighty Mouse Quadrax Cables

Sample Part Number	854-035	F	-A	C	-01	-12
Product	854-035 = Pre-wired quadrax contact					
Sealing Boot	F = Add grommet follower Omit for none					
P1 Connector	A = Quadrax, Pin (P/N 854-001) B = Quadrax, Socket (P/N 854-002)					
P2 Connector	A = Quadrax, Pin B = Quadrax, Socket	C = RJ45 Plug N = No Connector				
Cable Option	01 = Tensolite NF26Q100-01, 26 AWG 02 = Tensolite NF24Q100-01, 24 AWG 03 = Draka Fileca F 4704-6, 26 AWG 04 = Draka Fileca F 4704-4, 24 AWG 05 = Tensolite NF22Q100-01, 22 AWG					
Length	Overall length in inches					

854-035 Quadrax Cable Assemblies

Size #8 100 Ohm Quadrax Cable Assemblies, Wiring Dia

WIRING DIAGRAM
24/26 AWG PIN OR SOCKET FLYING LEADS

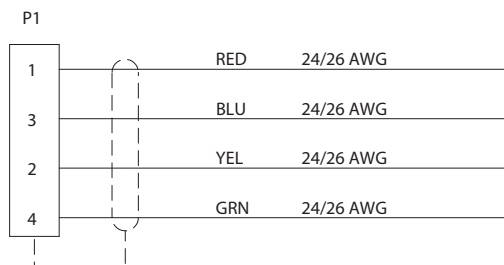

WIRING DIAGRAM
24/26 AWG BACK TO BACK PIN TO SOCKET

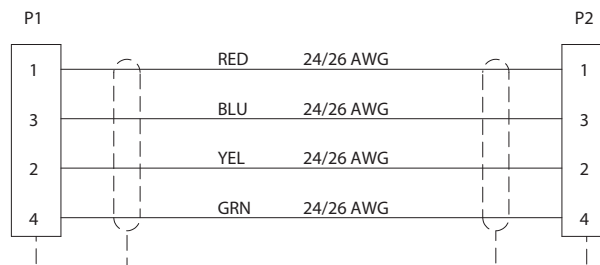

WIRING DIAGRAM
22 AWG PIN OR SOCKET FLYING LEADS

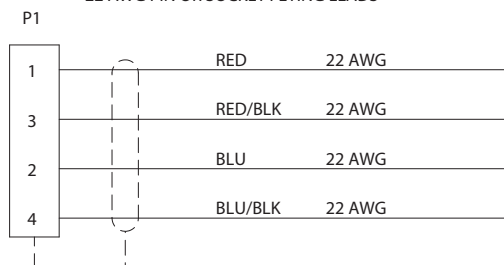

WIRING DIAGRAM
22 AWG BACK TO BACK PIN TO SOCKET

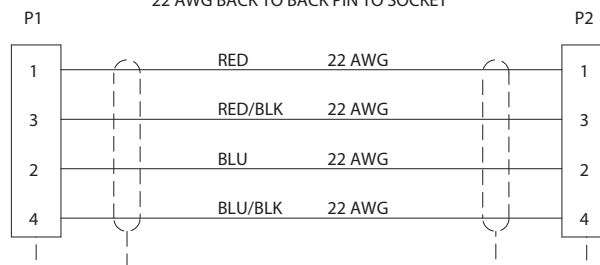

WIRING DIAGRAM
24/26 AWG PIN OR SOCKET TO RJ45

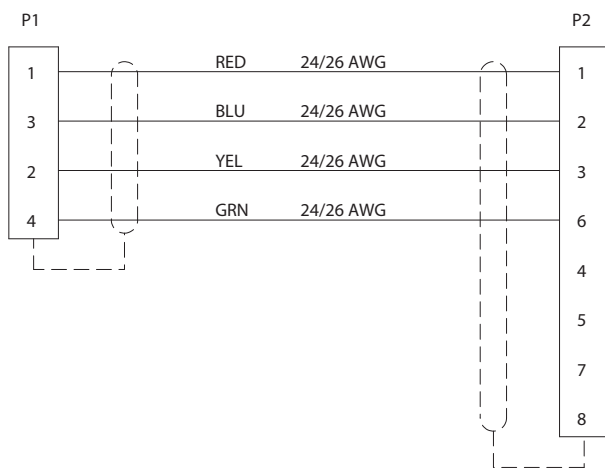

WIRING DIAGRAM
24/26 AWG PIN TO PIN OR SKT TO SKT

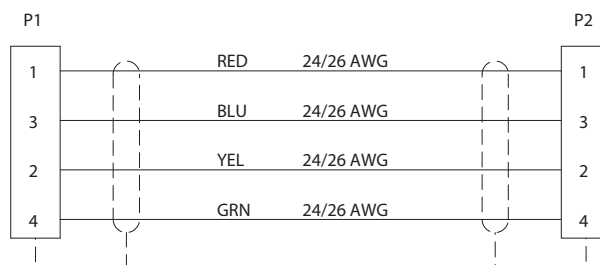

RF, Microwave and Datalink Contacts

for MIL-DTL-38999, SuperNine®, Mighty Mouse and Micro-Crimp® Connectors



El Ochito® Octaxial Contacts for 10G Ethernet

Size #8 100 Ohm El Ochito® Contacts

El Ochito® The 10G Ethernet Contact with Patented Data Pair Isolator Technology

United States Patent Number
9,257,796



Pin Contact



Socket Contact

El Ochito® contacts are intended for harsh environment military and aerospace data networks utilizing 1000BASE-T or 10GBASE-T protocols. El Ochito® contacts provide up to 50% total weight savings compared to quadrax-based solutions. These contacts have eight signal pins housed in a machined, gold plated outer contact. Crimp termination. Metal spline isolates data pairs for improved signal integrity. For use with aerospace-grade 26 AWG Category 6a cables with unshielded or shielded data pairs. El Ochito® contacts snap into ARINC 600 connectors with quadrax inserts, along with Series 80 Mighty Mouse and Series 23 SuperNine® connectors. Supplied as unassembled kit with outer body, (8) inner contacts, shield crimp ferrule, insulators, and instruction sheet.

DC – 4 GHz frequency range
100 ohms
Data pair isolation technology
50% size and weight savings compared to quadrax contacts

Snap-in, rear release
Sealing boot included
Gold plated copper alloy
10GBase-T compatible

Technical Data	
Specifications	Construction
Operating temperature: -65°C. to +175°C. Operating frequency: DC – 4 GHz Characteristic Impedance: 100 ±10 ohms Dielectric withstanding voltage, inner to inner contact: 1000 Vrms sea level, 250 Vrms 70,000 feet. Dielectric withstanding voltage, inner to outer contact: 500 Vrms sea level, 250 Vrms 70,000 feet. Insulation resistance: 5000 megohms min. Durability: 500 mating cycles Vibration: MIL-DTL-38999 Series III Shock: MIL-DTL-38999 Series III	Inner contacts, outer contact, shield crimp ferrule: copper alloy, 50 microinches gold over nickel plating Front, middle and rear insulator: PPS Sealing boot grommet: fluorosilicone Sealing boot body: rigid thermoplastic, PEI or equivalent
	Connector Compatibility
	El Ochito® contacts have an alignment key and are not for use in standard MIL-DTL-38999 connectors Glenair Series 80 Mighty Mouse Glenair 233-217 SuperNine® ARINC 600 quadraxial inserts

Size #8 El Ochito® Contacts for Aerospace High Speed Ethernet Cable

Connector Type	Cable Type	Cable Description	Cable		Pin Contact	Socket Contact
			Mfgr. Part Number	Glenair Part No.		
ARINC 600	S/UTP	Unshielded twisted pairs, 26 AWG	PIC E6A3826	963-003-26	858-009-01	858-010-01
	S/FTP	Foil shields on individual twisted pairs, 26 AWG	Gore RCN9047-26	963-033-26	858-009-02	858-010-02
Series 23 SuperNine® Series 80 Mighty Mouse	S/UTP	Unshielded twisted pairs, 26 AWG	PIC E6A3826	963-003-26	858-003-01F	858-004-01F
	S/FTP	Foil shields on individual twisted pairs, 26 AWG	Gore RCN9047-26	963-033-26	858-016-01F	858-017-01F

RF, Microwave and Datalink Contacts

for MIL-DTL-38999, SuperNine®, Mighty Mouse and Micro-Crimp® Connectors



El Ochito® Octaxial Contacts for 10G Ethernet

Size #8 100 Ohm El Ochito® Contacts

El Ochito® 10GbE Octaxial Contact Construction Details

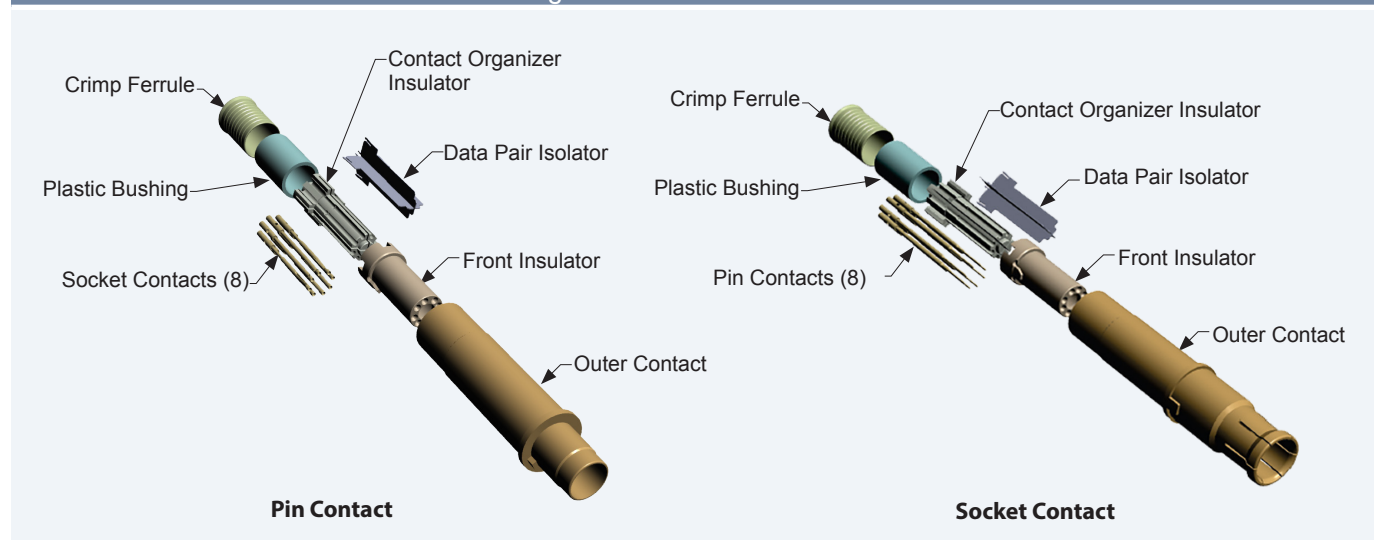

Contact PN	Inner Contacts		Outer Body		Removal Tool	Assembly Instructions
	Crimper	Positioner	Crimper	Hex Die		
858-003-01F 858-004-01F	809-015 (M22520/2-01)	859-101 (K1906)	809-129 (M22520/5-01)	859-007 (M22520/5-45)	859-049 (M81969/14-12)	AI85048
858-009-01 858-010-01	809-015 (M22520/2-01)	859-101 (K1906)	809-129 (M22520/5-01)	859-007 (M22520/5-45)	859-049 (M81969/14-12)	AI85074
858-009-02 858-010-02	809-015 (M22520/2-01)	859-101 (K1906)	859-145	(not required)	859-049 (M81969/14-12)	
858-016-01F 858-017-01F	809-015 (M22520/2-01)	859-101 (K1906)	859-134 (GS206)	(not required)	859-049 (M81969/14-12)	

Sealing Boot

Sealing boots are supplied with 858-003, 858-004, 858-016 and 858-017 contacts. To order these contacts without sealing boots, delete the "F" suffix from the part number. Sealing boots are not supplied with 858-009 and 858-010 contacts.

SEALING BOOT FOR OCHITO CONTACTS USING .220 (5.59) DIAMETER CABLE
687-754-8-8

RF, Microwave and Datalink Contacts

for MIL-DTL-38999, SuperNine[®], Mighty Mouse and Micro-Crimp[®] Connectors



El Ochito[®] Octaxial Contacts for 10G Ethernet

Size #8 100 Ohm El Ochito[®] Contacts

858-003 and 858-016 El Ochito[®] Pin Contact for 233-217 SuperNine[®] and Series 80 Mighty Mouse

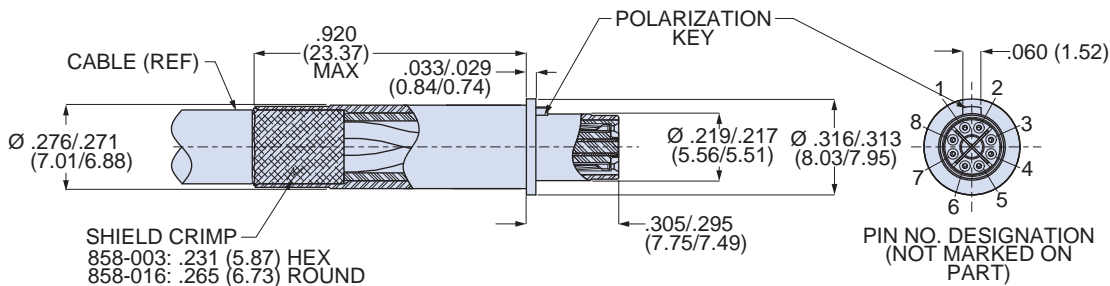

858-004 and 858-017 El Ochito[®] Socket Contact for 233-217 SuperNine[®] and Series 80 Mighty Mouse

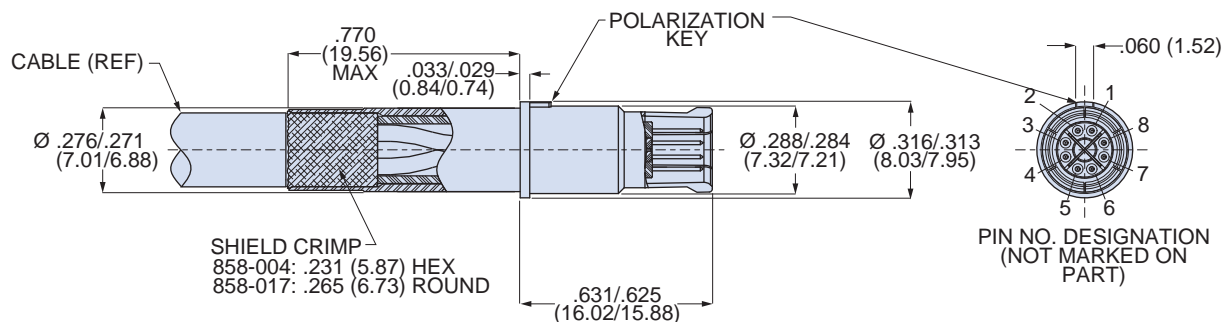

858-009 El Ochito[®] Pin Contact for ARINC 600 Connectors with Quadaxial Inserts

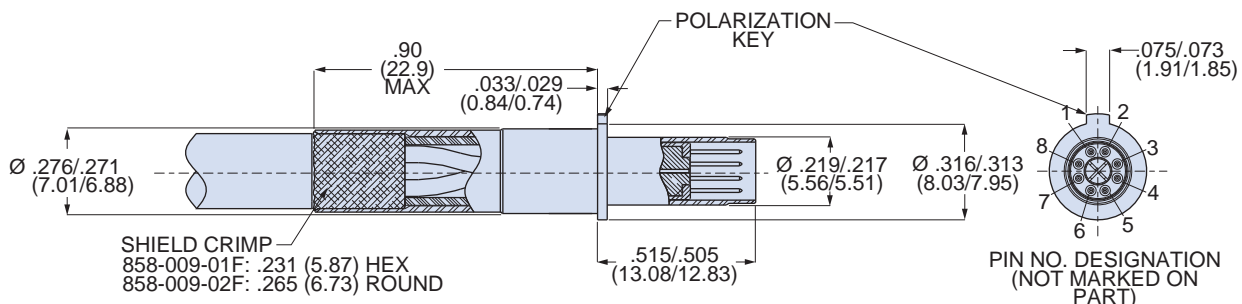

858-010 El Ochito[®] Socket Contact for ARINC 600 Connectors with Quadaxial Inserts

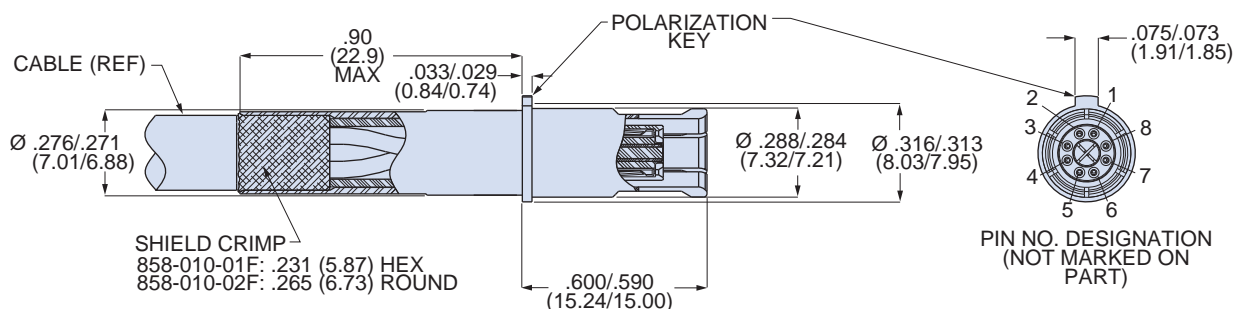

RF, Microwave and Datalink Contacts

for MIL-DTL-38999, SuperNine®, Mighty Mouse and Micro-Crimp® Connectors



El Ochito® Octaxial Contacts for 10G Ethernet

Wiring Guidelines

Implementation Guidelines for Terminating El Ochito® Contacts to 4-Pair Wire

ARINC Specification 664 Part 2- Appendix N provides guidelines for implementing 1000BASE-T and 10GBASE-T Ethernet links utilizing El Ochito® contacts. These guidelines provide instructions on maintaining the geometric relationship between the El Ochito® contact and the wire. The wire has an "A" end and a "B" end as shown in Figure 1. A contact installed on end "A" has a different wiring schematic than a contact installed on end "B". This is done to prevent the four wire pairs to be crossed contrary to their natural twist or lay. System designers and integrators should refer to ARINC 664 Part 2 for full guidance on specifying the connectors used throughout the data link.

The ARINC specification allows only four possible contact number-to-wire color combinations. Figure 2 shows these four combinations. The wire designer must specify which wire end (A or B) to terminate to each connector. Following the pin number- wire colors in Figure 2 will ensure cable assemblies are assembled with the correct wire rotation.

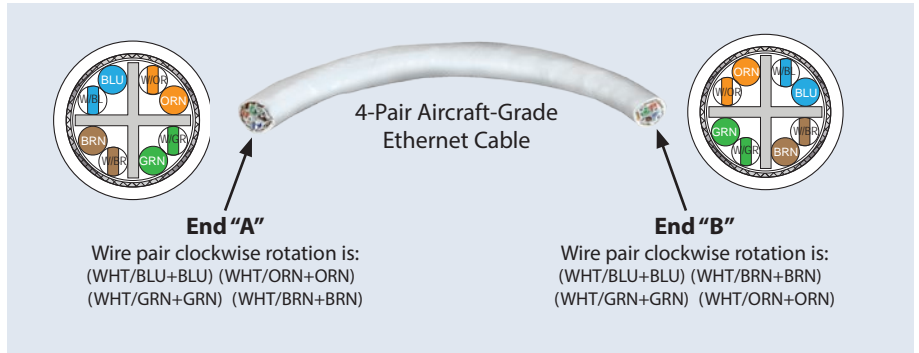

Figure 1 — Wire Rotation

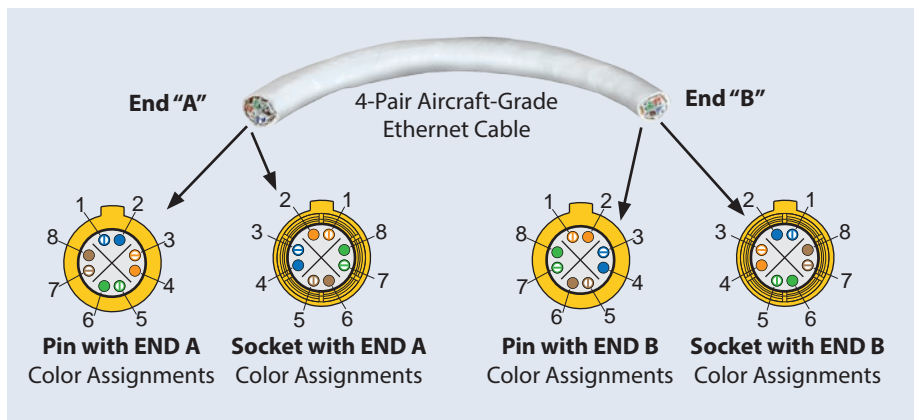

Figure 2 — Contact Color Assignment

ARINC 664 Wiring Configurations

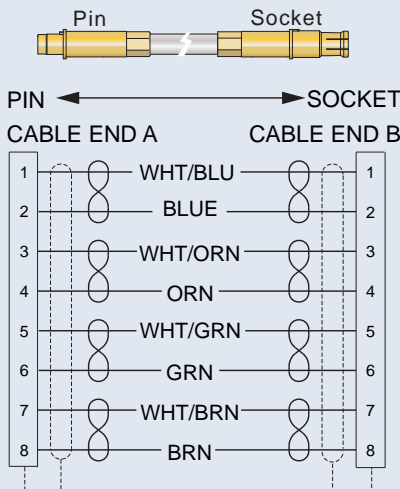

Figure 3

Schematic for Pin – Socket Wiring

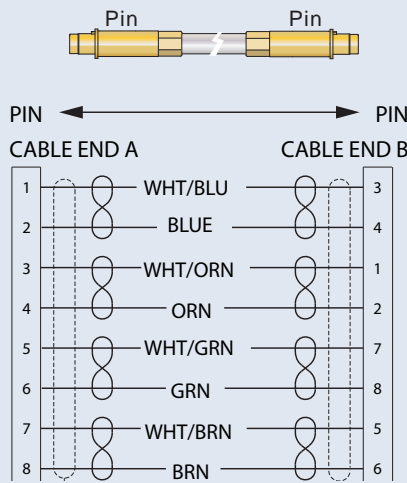

Figure 4

Schematic for Pin – Pin Wiring

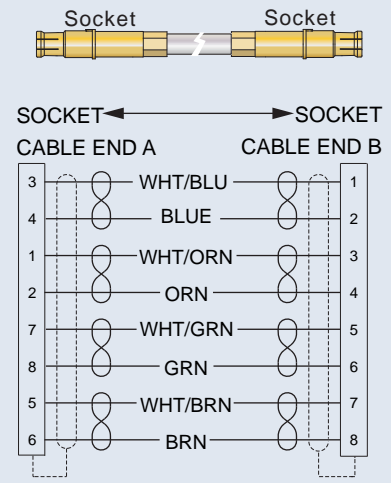

Figure 5

Schematic for Socket – Socket Wiring

RF, Microwave and Datalink Contacts

for MIL-DTL-38999, SuperNine[®], Mighty Mouse and Micro-Crimp[®] Connectors



El Ochito[®] Octaxial Contacts for 10G Ethernet

Signal Integrity Data

Excellent signal integrity at Gigabit speeds with S/UTP Cable

El Ochito[®] contacts with internal metal spline reduce crosstalk and attenuation for superior electrical bandwidth up to 9 Gbps. At -3dB insertion loss for a single mated pair at 4.1 GHz, the El Ochito[®] contact offers performance exceeding the requirements for 10 GbE interconnects.

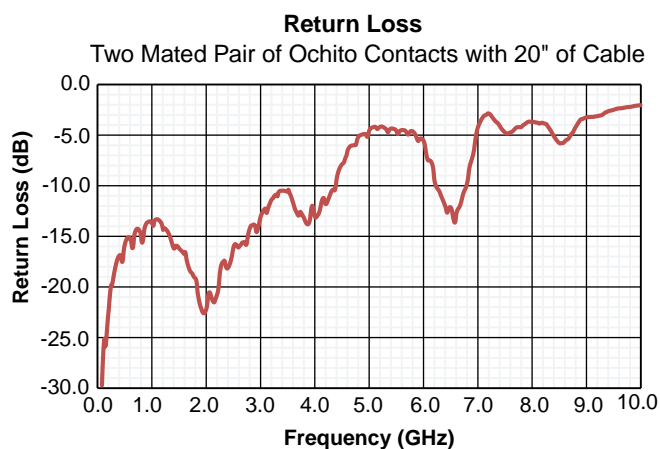
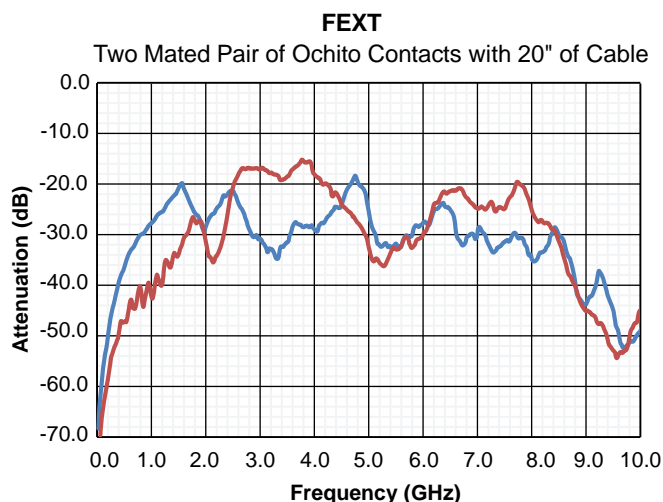
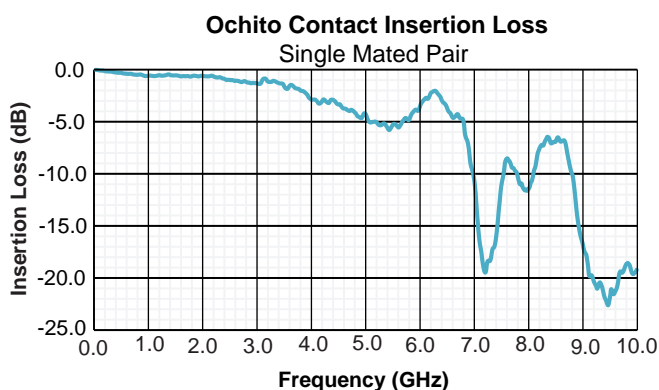

These graphs illustrate data shown in Glenair Test Report GT-15-40 "High Speed Characterization Report: El Ochito[®] Size 8 Multi-Pair Contact for Differential Applications". All measurements were taken using an Agilent E5071C network analyzer with TDR option connected to a SMA launch board designed specifically for this testing. Test cables were fabricated using 100 ohm Glenair twisted pair S/UTP Ethernet cable 963-003-26 terminated to El Ochito[®] pin contact 858-003. The mating PC tail socket 858-008 was assembled onto the PCB launch fixture shown below.

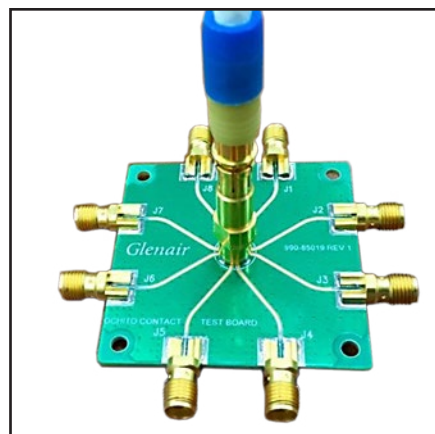
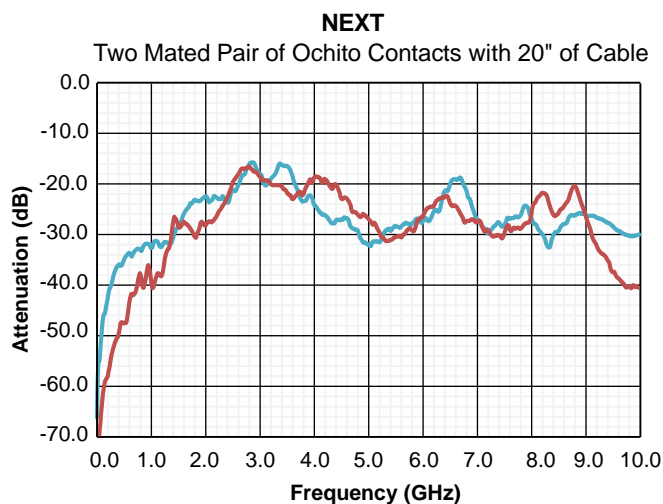

RF, Microwave and Datalink Contacts

for MIL-DTL-38999, SuperNine®, Mighty Mouse and Micro-Crimp® Connectors



El Ochito® Octaxial Contacts for 10G Ethernet

Signal Integrity Data

10GBase-T Cat 6a Compliance Testing

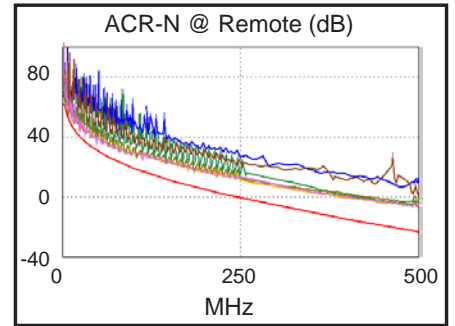
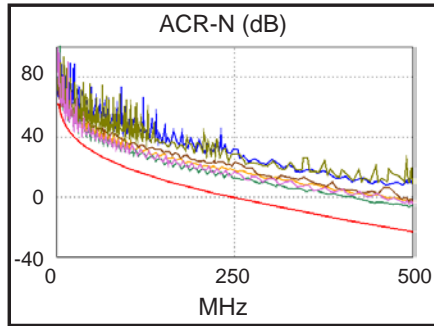
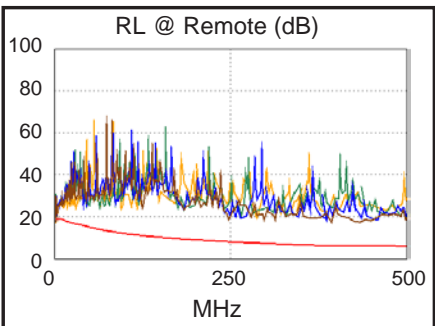
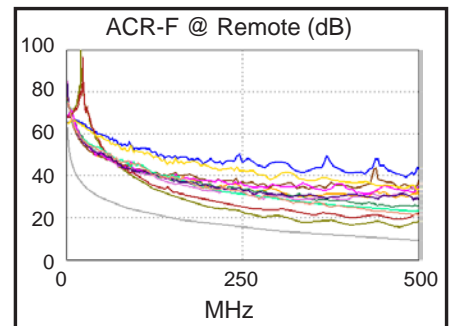
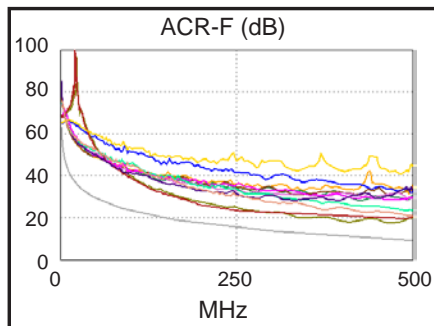
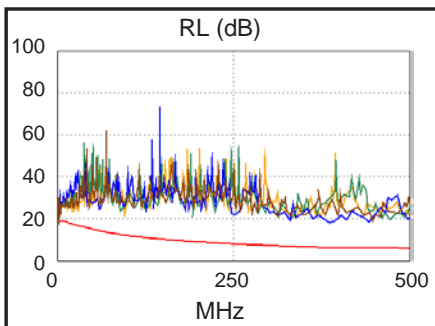
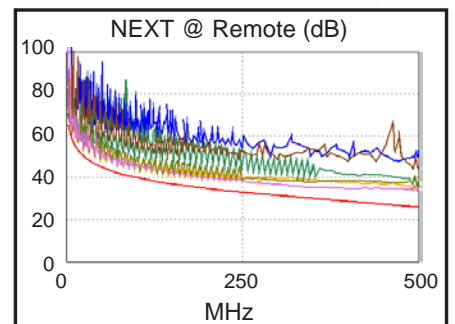
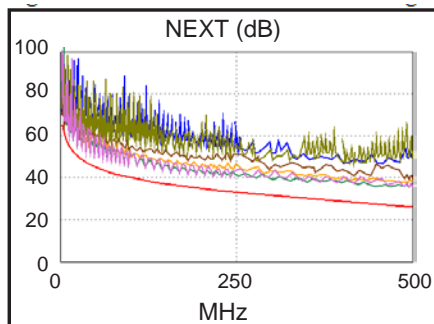
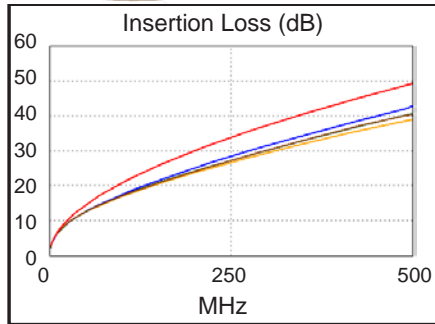
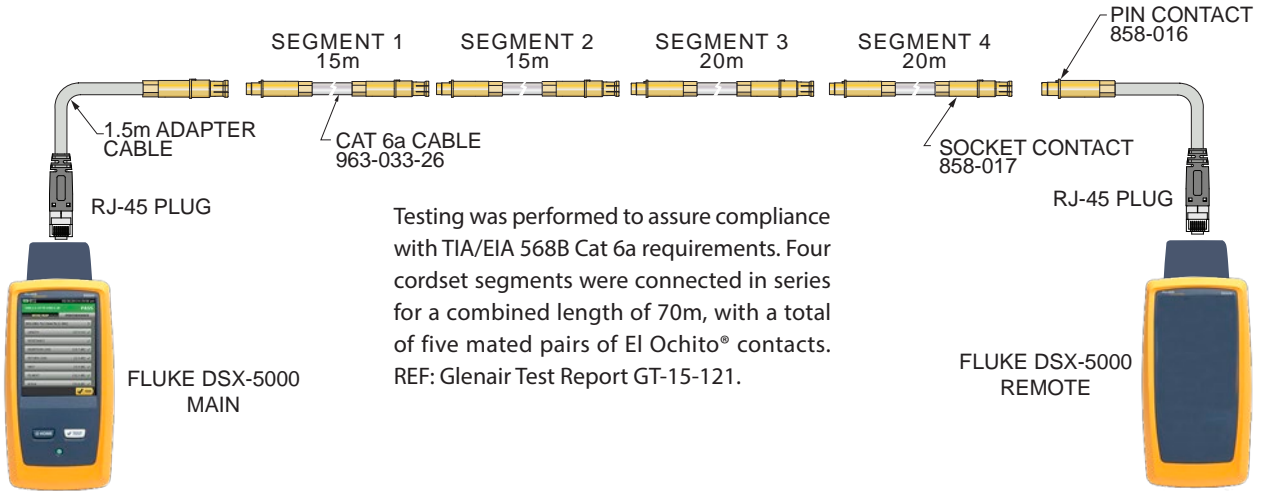

RF, Microwave and Datalink Contacts

for MIL-DTL-38999, SuperNine®, Mighty Mouse and Micro-Crimp® Connectors



El Ochito® Octaxial Contacts for 10G Ethernet

Aerospace Grade Category 6a Ethernet Cable

963-003-26 S/UTP Cable

S/UTP 26 AWG cable is small, lightweight and flexible. Twisted pairs are separated by a fluoropolymer spline for reduced crosstalk and attenuation. This 200°C rated cable is Skydrol resistant, RoHS compliant and meets FAA FAR Parts 23 and 25 Appendix F flammability requirements. Rugged, laser-markable PTFE jacket withstands abrasion and chemicals. Meets ANSI/TIA-568B Category 6a performance up to 193 feet.

S/UTP Cable	
Glenair Part No.	963-003-26
Manufacturer Part No.	E6A3826
Manufacturer	PIC
Construction Details	

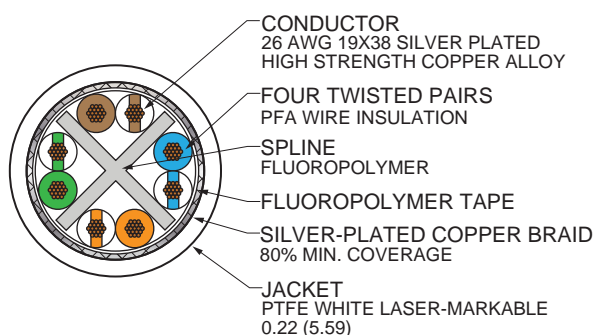

Color Code

Pair #1 Blue, White/Blue Pair #2 Orange, White/Orange Pair #3 Green, White/Green Pair #4 Brown, White/Brown

Specifications		
Impedance (ohms)	100	
Temperature Rating	-55 to +200 °C	
Weight (lbs/100 ft.)	3.5	
Capacitance (pF/ft)	14.5	
Minimum Bend Radius (inches)	0.66	
Velocity of Propagation %	70	
Dielectric Voltage Rating (kV rms)	1.5	
DC Resistance, Max (ohms/1000 ft.)	44.8	
Max Distance in Feet (m)	193 (59)	
Attenuation Nom / Max	Frequency	dB/100 ft.
	10 MHz	2.7 / 3.1
	100 MHz	8.7 / 10.5
	250 MHz	14.4 / 17.2
	500 MHz	20.7 / 24.9

963-033-26 S/FTP Cable

S/FTP 26 AWG cable has an individual foil shield around each data pair for reduced crosstalk and attenuation. This high data rate Ethernet cable features a unique cable jacket material and high-density construction that significantly reduces weight and diameter. Meets ANSI/TIA 568-C.2 Category 6a requirements up to 65 meters (213 feet).

S/FTP Cable	
Glenair Part No.	963-033-26
Manufacturer Part No.	RCN9047-26
Manufacturer	Gore
Construction Details	

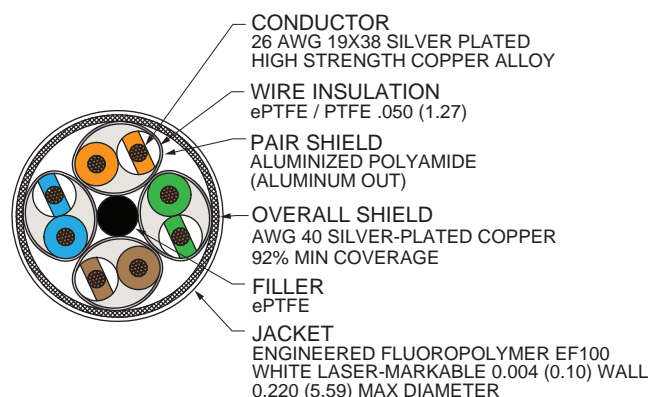

Color Code

Pair #1 Blue, White/Blue Pair #2 Orange, White/Orange Pair #3 Green, White/Green Pair #4 Brown, White/Brown

Specifications		
Impedance (ohms)	100 (+10 -5)	
Temperature Rating	-65 to +200 °C	
Weight (lbs/100 ft.)	3.2	
Capacitance (pF/ft)	12.5	
Time Delay	1.24 ns/ft	
Maximum Attenuation at 65m Length	Frequency	dB
	10 MHz	5.9
	100 MHz	19.1
	250 MHz	31.1
	500 MHz	45.3
NEXT (maximum)	Frequency	dB
	1 MHz	74.3
	10 MHz	59.2
	100 MHz	52.3
	250 MHz	47.9
500 MHz	42.2	

RF, Microwave and Datalink Contacts

for MIL-DTL-38999, SuperNine®, Mighty Mouse and Micro-Crimp® Connectors



El Ochito® Octaxial Contacts for 10G Ethernet

Pre-Wired El Ochito® Contacts



Pre-wired El Ochito® assemblies are 100% tested and ready for use. Compatible with Glenair 233-217 SuperNine or Series 80 Mighty Mouse connectors with keyed size #8 cavities, these assemblies are available with three termination options: single-ended, El Ochito® contacts on both ends, or with an RJ45 plug on one end. Two flight-grade cables are available: S/UTP (PIC) or S/FTP (Gore). Contacts are wired per the guidelines of ARINC 664 Part 2 Appendix N.

Technical Data Specifications
<ul style="list-style-type: none"> Operating temperature: -65°C. to +175°C. (El Ochito) or -40°C. to +85°C (RJ45) Meets EIA/TIA 568B.2-10 and IEC 60603-7-51 CAT6a 500 MHz Characteristic Impedance: 100 ohms Insulation resistance: 200 megohms min. Durability: 500 mating cycles

El Ochito® Construction
<ul style="list-style-type: none"> Inner contacts, outer contact, shield crimp ferrule: copper alloy, 50 microinches gold over nickel plating Front, middle and rear insulator: PPS Spline: copper alloy, nickel plated Sealing boot grommet: fluorosilicone Sealing boot body: rigid thermoplastic, PEI or equivalent

RJ45 Construction
<ul style="list-style-type: none"> Body: UL 94-V0 polycarbonate Grommet: UL 94-V0 polycarbonate Contacts: copper alloy, 50 microinches selective gold plating Shield: nickel-plated copper alloy

Connector Compatibility
<ul style="list-style-type: none"> Glenair Series 80 Mighty Mouse Glenair 233-217 SuperNine™

Notes
1. 100% tested for continuity, DWV and IR.
2. Wired per the guidelines of ARINC 664 Part 2 Appendix N.

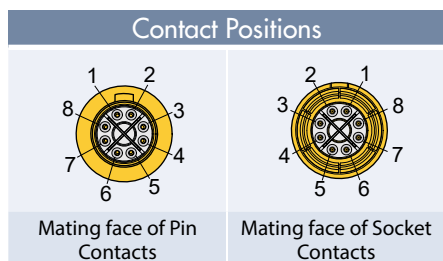

How To Order Pre-Wired El Ochito® Contacts						
	858-022	B	-A	C	-01	-36
Product	858-022 = Pre-wired El Ochito® contact					
Connector Type	A = ARINC 600 B = M38999 type (233-217 or Series 80 Mighty Mouse)					
End A Contact Type	A = El Ochito® pin contact B = El Ochito® socket contact					
End B Contact/Connector	A = El Ochito® pin contact B = El Ochito® socket contact C = RJ45 Cat6a shielded plug N = End B not terminated					
Cable Type	01 = S/UTP cable, #26 AWG, P/N 963-003-26 (PIC) 02 = S/FTP cable, #26 AWG, P/N 963-033-26 (Gore)					
Length	Overall length in inches					

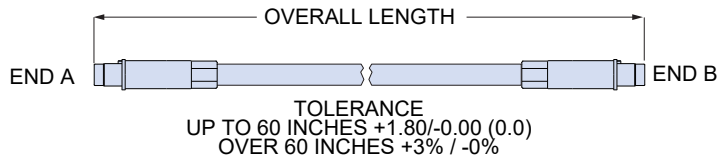

Ref. El Ochito® Contact Part Numbers				
Connector Type	Connector Description	Cable Type	Pin Contact	Socket Contact
A	ARINC 600	01	858-009-01	858-010-01
		02	858-009-02	858-010-02
B	Series 23 SuperNine®	01	858-003-01	858-004-01
	Series 80 Mighty Mouse	02	858-016-01	858-017-01

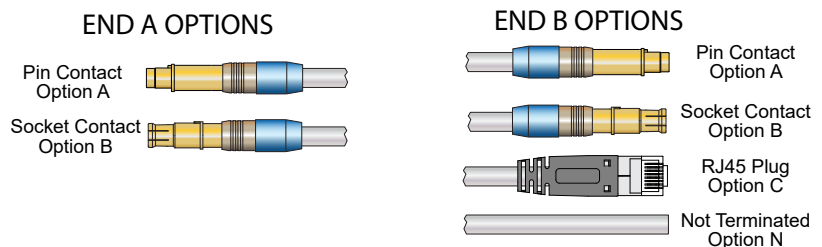

RF, Microwave and Datalink Contacts

for MIL-DTL-38999, SuperNine®, Mighty Mouse and Micro-Crimp® Connectors



El Ochito® Octaxial Contacts for 10G Ethernet

Pre-Wired El Ochito® Contacts

858-022 Pre-Wired El Ochito® Contact Schematics

Contacts are wired per the guidelines of ARINC 664 Part 2 Appendix N. These guidelines control the wire color assignments. The wire terminations depend on the contact gender and whether the contact is terminated to end "A" or end "B" of the wire.

The diagram at right shows the ARINC 664 Part 2 color assignments for each end of the wire. Following these guidelines ensure the wire geometry is maintained throughout the data link.

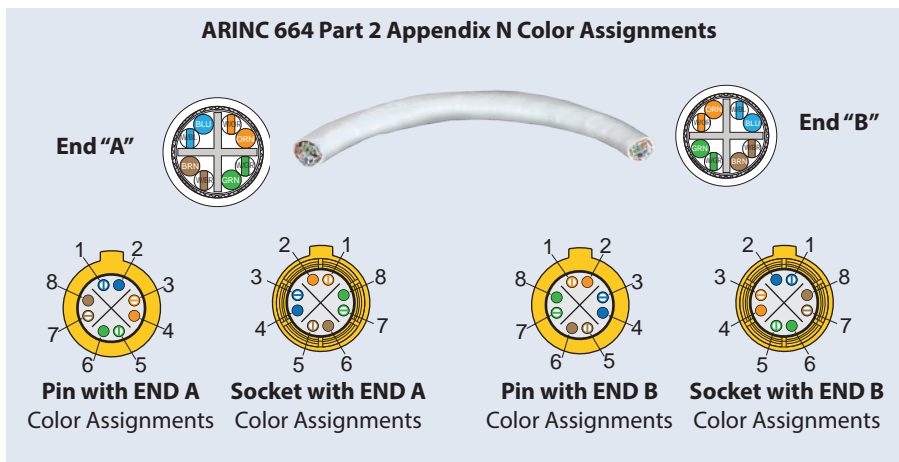

Single-Ended El Ochito® Pin or Socket

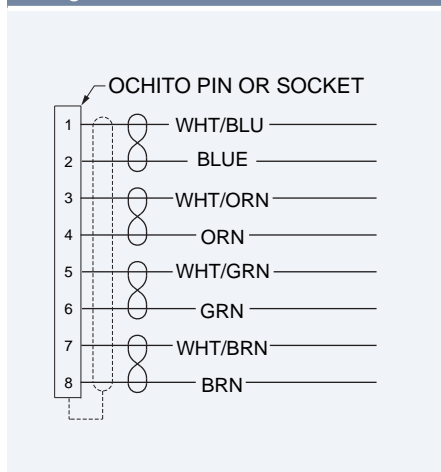

El Ochito® Pin to El Ochito® Pin

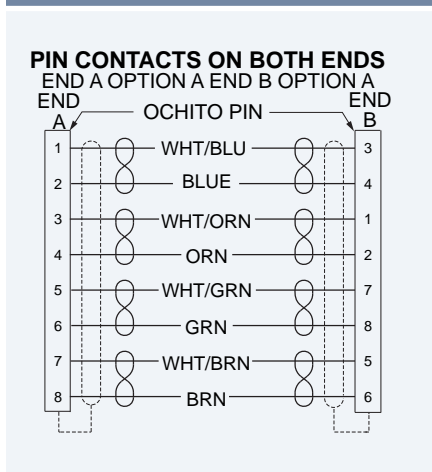

El Ochito® Socket to El Ochito® Socket

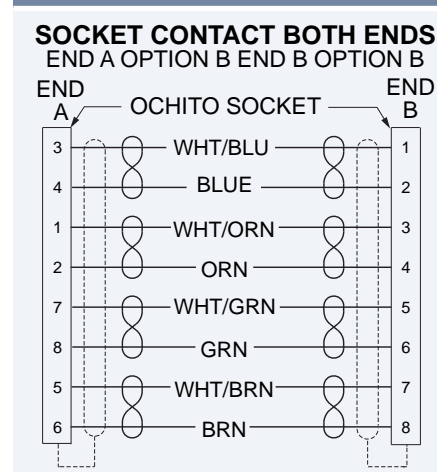

El Ochito® Pin End A to El Ochito® Socket

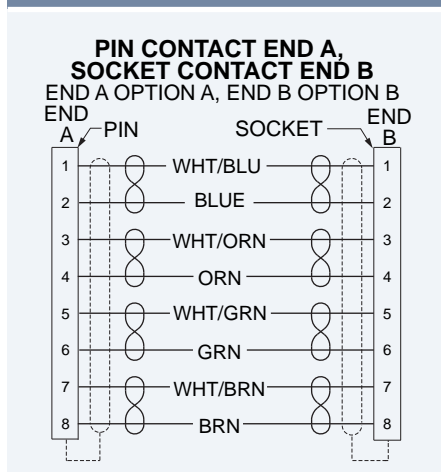

El Ochito® Socket End A to El Ochito® Pin

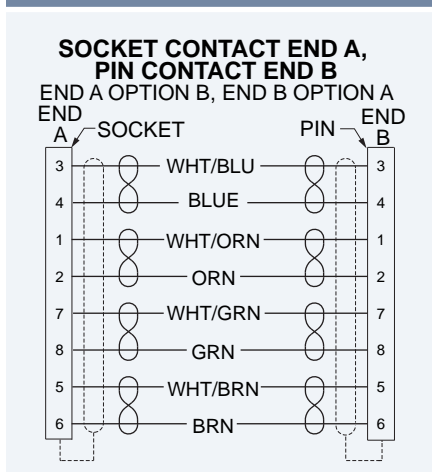

El Ochito® Pin or Socket to RJ-45

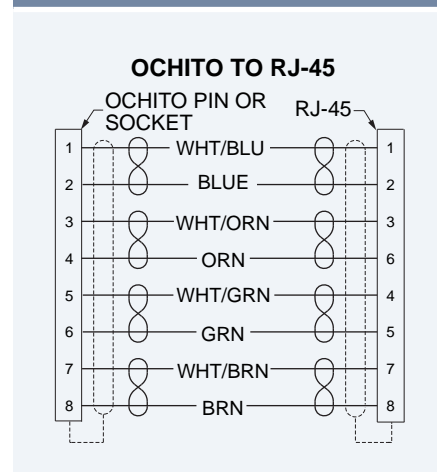

RF, Microwave and Datalink Contacts

for MIL-DTL-38999, SuperNine®, Mighty Mouse and Micro-Crimp® Connectors



El Ochito® Octaxial Contacts for 10G Ethernet

El Ochito® Test Adapters and Cables for SuperNine® Connectors



Plug Adapter

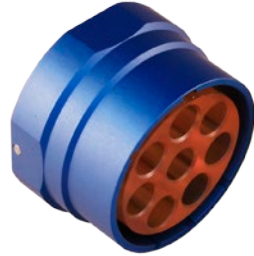

Receptacle Adapter

Prevent damage to expensive cables with El Ochito® test adapters and jumper cables. These test adapters properly align mating contacts without the added expense and time-consuming labor of mating connectors. Jumper cables are ordered separately. Push test adapter into Device Under Test (DUT), then insert adapter cable into adapter. No tool is required to insert and remove adapter cable. Jumper cables have high performance shielded EIA/TIA 568B.2-10 Cat6a RJ45 plug for interface with test instruments.

Construction
<p>Receptacle adapter (859-117P and 857-133S): polyetherimide resin, natural color</p> <p>Plug adapter (859-118S and 859-132P): polyetherimide insert, blue anodized aluminum alloy housing</p>
Connector Compatibility
<p>Glenair 233-217 SuperNine™ connectors with size 8 El Ochito® contacts</p>

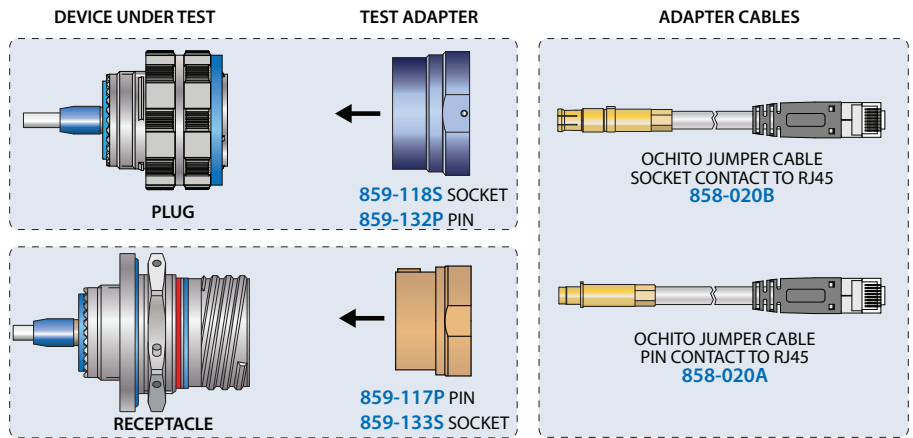

Ordering Information for El Ochito® Test Adapters (Jumper Cables not Included)

RECEPTACLE ADAPTER
MATES WITH PLUG CONNECTOR

859-118S
MATES WITH PLUG WITH PIN CONTACTS
859-132P
MATES WITH PLUG WITH SOCKET CONTACTS

PLUG ADAPTER
MATES WITH RECEPTACLE CONNECTOR

859-117P
MATES WITH RECEPTACLE WITH SOCKET CONTACTS
859-133S
MATES WITH RECEPTACLE WITH PIN CONTACTS

Arr.	Device Under Test			
	Plug with Pin Contacts ⁽¹⁾	Plug with Socket Contacts ⁽¹⁾	Receptacle with Pin Contacts	Receptacle with Socket Contacts
09G05	859-118S09G05N	859-132P09G05N	859-133S09G05	859-117P09G05
11-01	859-118S11-01N	859-132P11-01N	859-133S11-01	859-117P11-01
17-02	859-118S17-02N	859-132P17-02N	859-133S17-02	859-117P17-02
17-22	859-118S17-22N	859-132P17-22N	859-133S17-22	859-117P17-22
17-60	859-118S17-60N	859-132P17-60N	859-133S17-60	859-117P17-60
17-75	859-118S17-75N	859-132P17-75N	859-133S17-75	859-117P17-75
19-04	859-118S19-04N	859-132P19-04N	859-133S19-04	859-117P19-04
19-12	859-118S19-12N	859-132P19-12N	859-133S19-12	859-117P19-12
19-17	859-118S19-17N	859-132P19-17N	859-133S19-17	859-117P19-17
19-18	859-118S19-18N	859-132P19-18N	859-133S19-18	859-117P19-18
21-75	859-118S21-75N	859-132P21-75N	859-133S21-75	859-117P21-75
23-05	859-118S23-05N	859-132P23-05N	859-133S23-05	859-117P23-05
23-06	859-118S23-06N	859-132P23-06N	859-133S23-06	859-117P23-06
25-07	859-118S25-07N	859-132P25-07N	859-133S25-07	859-117P25-07
25-08	859-118S25-08N	859-132P25-08N	859-133S25-08	859-117P25-08
25-17	859-118S25-17N	859-132P25-17N	859-133S25-17	859-117P25-17
25-20	859-118S25-20N	859-132P25-20N	859-133S25-20	859-117P25-20
25-26	859-118S25-26N	859-132P25-26N	859-133S25-26	859-117P25-26
25-41	859-118S25-41N	859-132P25-41N	859-133S25-41	859-117P25-41
25-46	859-118S25-46N	859-132P25-46N	859-133S25-46	859-117P25-46

(1) For alternate polarizations, change suffix code from N to A, B, C, D or E.

RF, Microwave and Datalink Contacts

for MIL-DTL-38999, SuperNine®, Mighty Mouse and Micro-Crimp® Connectors



El Ochito® Octaxial Contacts for 10G Ethernet

El Ochito® Test Adapters and Cables for SuperNine® Connectors

859-117P Pin Adapter

Shell Size	A Diameter In.	A Diameter mm.
09 (A)	.650	16.5
11 (B)	.780	19.8
17 (E)	1.203	30.6
19 (F)	1.265	32.1
21 (G)	1.390	35.3
23 (H)	1.520	38.6
25 (J)	1.635	41.5

859-118S Socket Adapter

Shell Size	A Diameter In.	A Diameter mm.
09 (A)	.710	18.0
11 (B)	.850	21.6
17 (E)	1.271	32.3
19 (F)	1.333	33.9
21 (G)	1.460	37.1
23 (H)	1.585	40.3
25 (J)	1.711	43.5

859-132P Pin Adapter

Shell Size	A Diameter In.	A Diameter mm.
09 (A)	.710	18.0
11 (B)	.850	21.6
17 (E)	1.271	32.3
19 (F)	1.333	33.9
21 (G)	1.460	37.1
23 (H)	1.585	40.3
25 (J)	1.711	43.5

859-133S Socket Adapter

Shell Size	A Diameter In.	A Diameter mm.
09 (A)	.650	16.5
11 (B)	.780	19.8
17 (E)	1.203	30.6
19 (F)	1.265	32.1
21 (G)	1.390	35.3
23 (H)	1.520	38.6
25 (J)	1.635	41.5

El Ochito® Test Jumpers with Pin Contacts

El Ochito® Test Jumpers with Socket Contacts

Pin Jumper Ordering Information

Overall Length		Part Number
Inches	meters	
18	0.45	858-020-A-02-18
36	0.91	858-020-A-02-36
72	1.82	858-020-A-02-72
120	3.05	858-020-A-02-120

Socket Jumper Ordering Information

Overall Length		Part Number
Inches	meters	
18	0.45	858-020-B-02-18
36	0.91	858-020-B-02-36
72	1.82	858-020-B-02-72
120	3.05	858-020-B-02-120

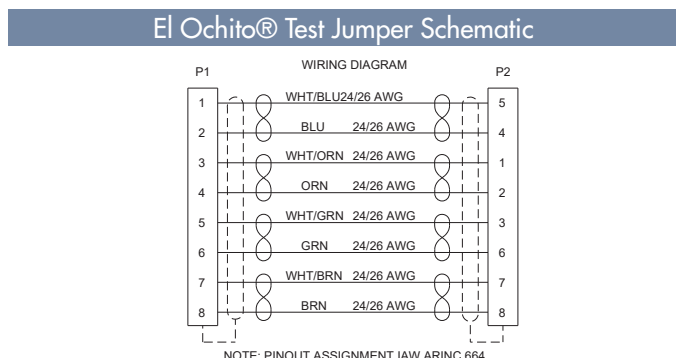

- #### Notes
- 858-020 jumper cables are intended only for use in Glenair El Ochito® test adapters. Do not attempt to install in MIL-DTL-38999 type connectors.
 - Other cable lengths are readily available. Change the suffix number to the desired length in inches.
 - 858-020 jumper cables are fully assembled and 100% electrically tested.
 - Length is minimum overall length including contact and plug.
 - No tool is required to install or remove contacts.
 - Jumper cables are wired per the guidelines of ARINC 664 Part 2 Appendix N.

RF, Microwave and Datalink Contacts

for MIL-DTL-38999, SuperNine®, Mighty Mouse, and
Micro-Crimp Connectors



Part Number Index

Part Number Index

Part Number	Page No.
852-001.....	7
852-002.....	7
852-003.....	7
852-004.....	7
852-005.....	7
852-006.....	6
852-007.....	6
852-008.....	8
852-009.....	8
852-010.....	8
852-015.....	12
852-016.....	12
852-017.....	12
852-018.....	12
852-019.....	12
852-024.....	24
852-025.....	24
852-030.....	10
852-031.....	10
852-032.....	24
852-037.....	12
852-042.....	10
852-043.....	10
852-056.....	14
852-057.....	14
852-070.....	22
852-071.....	22
852-082.....	14
852-083.....	14
852-103.....	16
852-104.....	16
852-106.....	16
853-003.....	26
853-004.....	26
853-008.....	30
853-009.....	30
853-011.....	28
853-012.....	28
853-013.....	32
853-014.....	32
853-015.....	35
853-016.....	35
853-024.....	32
853-025.....	32
854-001.....	37
854-002.....	37

Part Number	Page No.
854-014.....	36
854-015.....	36
858-003.....	40
858-004.....	40
858-009.....	40
858-010.....	40
858-016.....	40
858-017.....	40
858-020.....	50
858-022.....	47
859-117.....	49
859-118.....	49
859-132.....	49
859-133.....	49
960-130.....	18
960-131.....	18
960-132.....	18
962-001.....	25
963-003.....	46
963-019.....	39
963-020.....	39
963-021.....	39
963-022.....	39
963-023.....	39
963-024.....	39
963-033.....	46
M39029/27-210.....	7
M39029/27-402.....	7
M39029/28-211.....	7
M39029/28-409.....	7
M39029/59-366.....	6
M39029/60-367.....	6
M39029/75-416.....	7
M39029/75-417.....	7
M39029/76-424.....	8
M39029/76-425.....	8
M39029/77-428.....	8
M39029/77-429.....	8
M39029/78-432.....	8
M39029/78-433.....	8
M39029/102-558.....	7
M39029/103-559.....	7
M39029/113-625.....	26
M39029/114-628.....	26



TECHNOLOGY OVERVIEW

Glenair High-Speed Interconnect Solutions



OctoByte™ 4/8 pole modular contact system for industrial applications



Series 80 Mighty Mouse High-Speed with matched-impedance Teflon® inserts

A complete range of electrical, fiber optic, and opto-electronic interconnect solutions for harsh environment Ethernet, RF, microwave, and other high-speed matched-impedance military and aerospace applications

EL OCHITO® OCTAXIAL MATCHED-IMPEDANCE 10G ETHERNET CONTACT



El Ochito®: The 10G Ethernet contact with patented data pair isolation technology

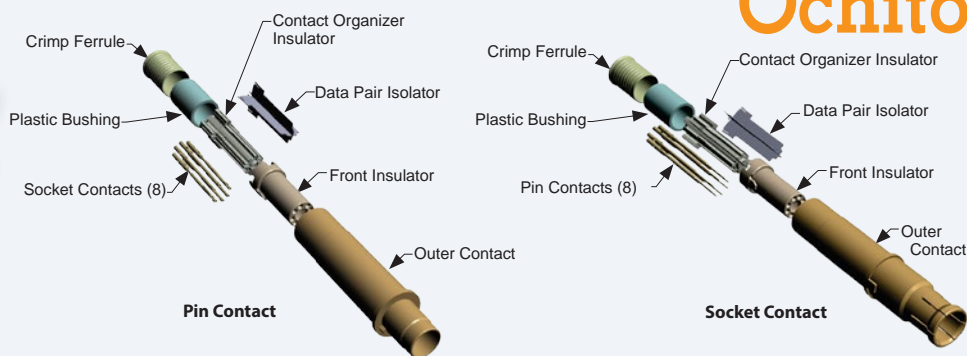

TECHNOLOGY OVERVIEW

Glenair High-Speed Interconnect Solutions



RF, MICROWAVE, AND DATALINK CONTACTS



AS39029 Coaxial



Spring-loaded Microwave Coax



Concentric Twinax



Differential Ultra-Twinax



Quadrax

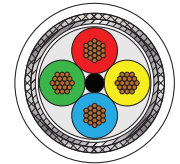

High-Performance Cable

SUPERSEAL FIELD RJ45 AND USB SOLUTIONS



Series 80 Mighty Mouse Micro-USB



SuperNine® RJ45



SuperNine® USB



HARSH-ENVIRONMENT OPTO-ELECTRONIC TECHNOLOGIES



Small form-factor transceiver

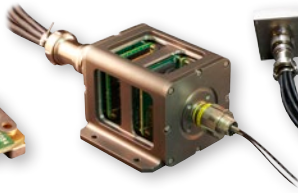

Signal aggregation media converter



7-port Ethernet switch



DVI video media converter

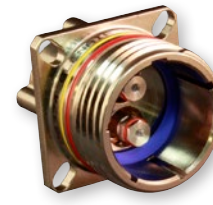

Photonic connectors and modules



Size #8 Photonic contacts

HARSH-ENVIRONMENT FIBER OPTIC INTERCONNECT SYSTEMS



MIL-DTL-38999 Type Fiber Optic



Glenair High Density (GHD)



Series 80 Mighty Mouse Fiber Optic



MIL-PRF-28876 QPL



MT Ferrule Fiber Optic



ARINC 801

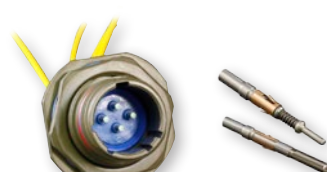

Eye-Beam® GLT Expanded-Beam Grin-Lens Termini



Eye-Beam® GMA HMA-type Ball Lens



Out of This World
**INTERCONNECT
SOLUTIONS**

Glenair, Inc.

1211 Air Way • Glendale, California • 91201-2497

Telephone: 818-247-6000 • Fax: 818-500-9912 • sales@glenair.com

www.glenair.com

**Glenair Power
Products Group**

860 N. Main Street Extension
Wallingford, CT
06492

Telephone:
203-741-1115
Facsimile:
203-741-0053
sales@glenair.com

Glenair UK Ltd

40 Lower Oakham Way
Oakham Business Park
P.O. Box 37, Mansfield
Notts, NG18 5BY England

Telephone:
+44-1623-638100
Facsimile:
+44-1623-638111
sales@glenair.co.uk

Glenair Microway Systems

7000 North Lawndale Avenue
Lincolnwood, IL
60712

Telephone:
847-679-8833
Facsimile:
847-679-8849

Glenair Nordic AB

Gustav III : S Boulevard 46
SE-169 27 Solna
Sweden

Telephone:
+46-8-50550000
sales@glenair.se

Glenair Electric GmbH

Schaberweg 28
61348 Bad Homburg
Germany

Telephone:
06172 / 68 16 0
Facsimile:
06172 / 68 16 90
info@glenair.de

Glenair Iberica

C/ La Vega, 16
45612 Velada
Spain

Telephone:
+34-925-89-29-88
Facsimile:
+34-925-89-29-87
sales@glenair.es

Glenair Italia S.p.A.

Via Del Lavoro, 7
40057 Quarto Inferiore –
Granarolo dell'Emilia
Bologna, Italy

Telephone:
+39-051-782811
Facsimile:
+39-051-782259
info@glenair.it

Glenair France SARL

7, Avenue Parmentier
Immeuble Central Parc #2
31200 Toulouse
France

Telephone:
+33-5-34-40-97-40
Facsimile:
+33-5-61-47-86-10
sales@glenair.fr

Glenair Korea

B-1304 Gunpo IT Valley
148 Gosan-Ro, Gunpo-Si
Kyunggi-Do, Korea
435-733

Telephone:
+82-31-8068-1090
Facsimile:
+82-31-8068-1092
sales@glenair.kr

